

Think like a Brainiac.
Drive like a Maniac.

Platform-Puzzle-Driving-Action

GripShift™



(PlayStation Portable)

ULES-00175

PlayStation™, PSP™ and UMD™ are trademarks or registered trademarks of Sony Computer Entertainment Inc. All rights reserved. Made in Austria. GripShift™ © 2006 Prology Design Limited. GripShift is published under license from Prology Design Limited and Red Mile Entertainment, Inc. Red Mile Entertainment and the Red Mile Entertainment logo are trademarks of Red Mile Entertainment, Inc. Sidhe and Sidhe are trademarks or registered trademarks of Prology Design Limited. Published and distributed by Ubisoft Entertainment under license from Sony Online Entertainment. Ubisoft and the Ubisoft logo are trademarks of Ubisoft Entertainment in the U.S. and/or other countries.

PlayStation, PSP, UMD and the PS logo are trademarks or registered trademarks of Sony Computer Entertainment Inc. All Rights Reserved.

3307210207715

FRANTIX™



DEVELOPED BY

WallerGame



UBISOFT

PRECAUTIONS

This disc contains game software for the PSP™ (PlayStation®Portable) system. Never use this disc on any other system, as it could damage it. Read the PSP™ system Instruction Manual carefully to ensure correct usage. Do not leave the disc near heat sources or in direct sunlight or excessive moisture. Do not use cracked or deformed discs or discs that have been repaired with adhesives as this could lead to malfunction.



Push down one side of the disc as shown and gently pull upwards to remove it. Using excess force to remove the disc may result in damage.



Place the disc as shown, gently pressing downwards until it clicks into place. Storing the disc incorrectly may result in damage.

HEALTH WARNING

Always play in a well lit environment. Take regular breaks, 15 minutes every hour. Avoid playing when tired or suffering from lack of sleep. Some individuals are sensitive to flashing or flickering lights or geometric shapes and patterns, may have an undetected epileptic condition and may experience epileptic seizures when watching television or playing videogames. Consult your doctor before playing videogames if you have an epileptic condition and immediately should you experience any of the following symptoms whilst playing: dizziness, altered vision, muscle twitching, other involuntary movement, loss of awareness, confusion and/or convulsions.

PIRACY

The PSP™ system and this disc contain technical protection mechanisms designed to prevent the unauthorised reproduction of the copyright works present on the disc. The unauthorised use of registered trademarks or the unauthorised reproduction of copyright works by circumventing these mechanisms or otherwise is prohibited by law.

If you have any information about pirate product or methods used to circumvent our technical protection measures please email anti-piracy@eu.playstation.com or call your local Customer Service number given at the back of this manual.

PARENTAL CONTROL

This PSP™ (PlayStation®Portable) Game software has a preset Parental Control Level based on its content. You can set the Parental Control Level on the PSP™ system to restrict the playback of a PSP™ Game with a Parental Control Level that is higher than the level set on the PSP™ system. For more information, please refer to the PSP™ system Instruction Manual.

PARENTAL CONTROL LEVEL

9
7
5
3
2

AGE GROUP

Restricted to 18 and over

Not suitable for under 15 unless accompanied by an adult

Recommended for mature players

Parental guidance recommended

General



ULES-00175

Frantix © 2005 Sony Online Entertainment Inc. Platform Publishing and the Platform Publishing logo are trademarks of Sony Online Entertainment Inc. The ChubbChudds! and characters TM & © 2002 Sony Pictures Imageworks, Inc. ACADEMY AWARDS® is the registered trademark and service mark of the Academy of Motion Picture Arts and Sciences. The Killer Game logo is a registered trademark of the Killer Game Corporation in the U.S. Library programs © 2003-2005 Sony Computer Entertainment Inc. exclusively licensed to Sony Computer Entertainment Europe. FOR PERSONAL USE ONLY. Unauthorised copying, adaptation, rental, lending, distribution, extraction, re-sale, arcade use, charging for use, broadcast, public performance and internet, cable or any telecommunications transmission, access or use of this product or any trademark or copyright work that forms part of this product are prohibited. Published and distributed by Ubisoft Entertainment under license from Sony Online Entertainment Inc. Ubisoft and the Ubisoft logo are trademarks of Ubisoft Entertainment in the U.S. and/or other countries.



getting started

Set up the PSP™ system according to the instructions in its instruction manual. Turn the PSP™ system on and the POWER indicator will light up green. The Home Menu will be displayed. Press the OPEN latch to open the disc cover. Insert the FRANTIX disc with the label side facing the rear of the PSP™ system and then securely close the disc cover.

Select the  icon from the Home Menu and then select the  icon. An image of the software will be displayed. Select the image and press the  button to commence loading.

PLEASE NOTE: the information in this manual was correct at the time of going to print, but some minor changes may have been made late in the product's development. All screenshots for this manual have been taken from the English version of this product, and some screenshots might have been taken from pre-completion screens that differ slightly from those in the finished product.

memory stick duo™

To save game settings and progress, insert a Memory Stick Duo™ into the Memory Stick Duo™ slot of the PSP™ system. Saved game data can be loaded from the same Memory Stick Duo™ or any Memory Stick Duo™ containing previously saved game data.

This title uses an auto-load and auto-save feature. It is not possible to manually save or load your progress.



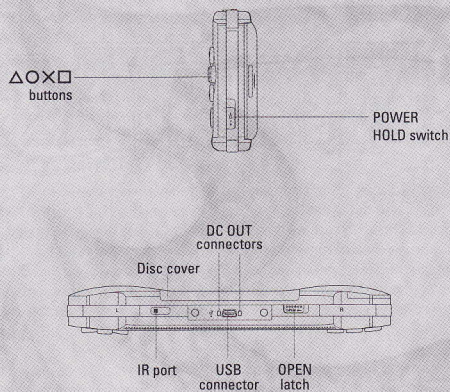

WIRELESS (WLAN) FEATURES

Software titles that support Wireless (WLAN) functionality allow the user to communicate with other PSP™ systems, download data and compete against other users via connection to a Wireless Local Area Network (WLAN).



AD HOC MODE

Ad Hoc Mode is a Wireless (WLAN) feature that allows two or more individual PSP™ systems to communicate directly with each other.



GAME SHARING

Some software titles feature Game Sharing facilities which enable the user to share specific game features with other users who do not have a PSP™ Game in their PSP™ system.



INFRASTRUCTURE MODE

Infrastructure Mode is a Wireless (WLAN) feature that allows the PSP™ system to link to a network via a Wireless (WLAN) Access Point (a device used to connect to a Wireless network). In order to access Infrastructure Mode features, several additional items are required, including a subscription to an Internet Service Provider, a network device (e.g. a Wireless ADSL Router), a Wireless (WLAN) Access Point and a PC. For further information and setting up details, please refer to the PSP™ system Instruction Manual.

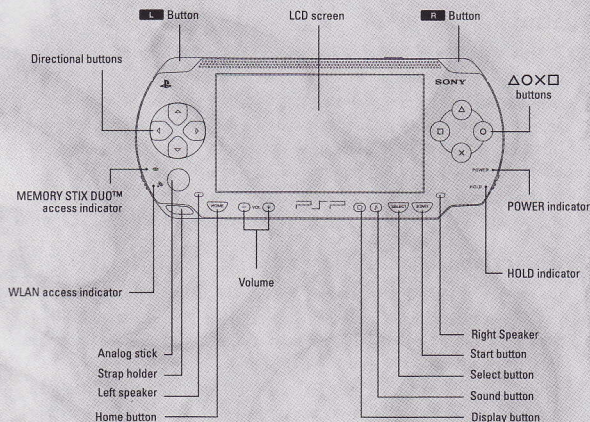

Main Menu



1. World Name
2. Level
3. Total number of gems collected
4. Total number of gold gems earned.
5. Number of gems collected on this level
6. Best time for completing this level
7. Hero name
8. Hero image
9. Credits
10. Total time played

gameplay

Starting a Game

To begin a game for the first time, you will start in the World Tutorialandia on the level Gems & Exit. In Tutorialandia you will learn the basics of solving puzzles in **FRANTIX**. From the main menu, select your hero by highlighting the name and pressing the left or right directional buttons. There are four heroes in **FRANTIX**, though some may be locked and require a certain number of gems collected in order to play them. The heroes are Bear, Kaz, Uri, and Meeper.

To begin the selected level, press the **X** button. The main menu will display your progress and allow you to choose your hero and level to play.

Objectives

The objective in **FRANTIX** is to gather gems in the strange, dream-like puzzle worlds your hero ventures through, before time runs out. These gems can unlock different areas of the current level, higher levels and worlds, with more complex puzzles and new themes, as well as new heroes to play.

Each level of each world has a gem requirement you must have reached in order to play that level. In the main menu you can see what is required to unlock a level by scrolling through, using the left and right directional buttons. Next to the gem icon below the level name you will see the number of gems needed to unlock that level.

Controls

Move your hero using the directional buttons.

- ← button** Moves your hero one step to the left.
- button** Moves your hero one step to the right.
- ↓ button** Moves your hero one step backward.

Note that you may also use the analog stick to control your hero.

Adjust your camera view by using the following buttons:

- △ button** Toggles the camera view between far behind, directly over-head, and close behind your hero.
- L button** Rotates the camera view 90 degrees clockwise around your hero.
- R button** Rotates the camera view 90 degrees counterclockwise around your hero.

To pause the game, press the **START** button. This will open the Pause menu. From here, you may resume play when ready, restart the current level, or quit to return to the main menu.

Puzzles

FRANTIX requires quick thinking, a cool head, and good problem-solving abilities. Each level of the game will challenge you with puzzles to solve that will allow your hero to move through it and escape to the next level or world. But don't dawdle; you have a limited amount of time in which to make it through each level.



1. Countdown clock
2. Gems remaining to be collected
3. Level title
4. Your hero
5. A gem
6. Question mark clue
7. Enemy creature
8. Switch
9. Object

Question Mark Clues

In some levels you will see question mark symbols on the ground. Move your hero over these symbols to receive a clue for solving that level. Be sure to read all clues in a level as they provide invaluable information, including tips on how to traverse hazards or unlock sealed off areas.

Collecting Gems



To progress through **FRANTIX** you must collect gems. In order to successfully complete a level, you must collect the number of gems indicated in the upper right corner of the screen and reach the exit portal before the time limit expires.

To pick up a gem, simply maneuver your hero over the gem. It will be picked up automatically and added to your collection. The more gems you collect, the more levels and other game features you can unlock.

Time Limits

You have a limited time to solve the puzzles and maneuver your hero through levels. In the upper right corner of the screen is a clock icon with a countdown in seconds. If the countdown reaches zero, you will have to replay the level.

Gold Gem Time Limits



Completing a level in an exceptionally short time can earn you a special reward: a gold gem.

Pickups

You may find pickups that grant special temporary effects to your hero. Not all effects may be beneficial, so be prepared when you run into them. To take a pickup, simply run into it with your hero. Here are some pickups that you might find, and their effects:

- **Haste Boost:** Doubles your speed for five seconds. Unless your hero hits a wall, you won't be able to stop your forward movement while under this effect.
- Note** — You can still change your direction of movement while under this effect, but it will be very difficult to do so.
- **Haste Minus:** Reduces your speed by half for five seconds. You can't stop your forward movement while under this effect unless your hero encounters a wall.
- Note** — You can still change your direction of movement while under this effect, but it is very difficult.
- **Time Boost:** Increases your remaining time by 30 seconds.
- **Invincibility:** Allows you to walk safely on any hazard, trap, or enemy for five seconds.

Hazards

Hazards can end your journey through the dream world of **FRANTIX** very quickly. Lava and water, for example, cannot be crossed without a bridge of some sort, including boxes you can move that allow you to cross safely. Quicksand requires that you cross it quickly, no turning back. If you do, your hero is sunk, literally!

Creatures

You will encounter a host of strange creatures as you explore the dream-scapes of **FRANTIX**. They can spell trouble for your hero, sometimes frustrating your progress by merely blocking your way, but often seeking to end your time in their world, so be careful. Pay attention to their behaviour. In some cases, how they move and react to your hero can be used to your advantage.



Objects

Throughout many levels you will find objects such as boxes, bombs, and more, that can help you pass obstacles. For example, boxes can be pushed into dangerous hazards, such as water or lava, allowing you to gingerly cross and avoid the obstacle.

To push an object, maneuver your hero into position next to the object and push it in the direction you wish it to go.

If an object you need is against a wall or in a corner and you're no longer able to push it into a certain position, you may "pull" the object out of the corner. To pull an object, position your hero next to it. Push against the object by pressing the direction button toward the object and then quickly press the opposite direction button away from the object. Your hero will then pull the object one space away from the wall or corner.

Note that some objects (for example bombs) have special effects and moving them may initiate their effect. Moving a bomb will ignite the fuse, so make sure you know what you're going to do with it before you push it!

Portals, Doors, and Walls

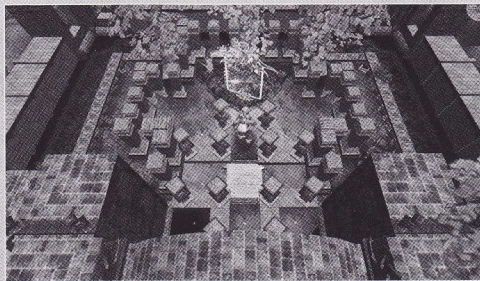

There are a variety of walls and portals in many levels of **FRANTIX**. Portals will move your hero instantly to different locations within the level, often to locations unreachable by other means.

Doors and walls function in different ways in many levels. Some allow you only to pass through one direction, others will allow you to pass through only one time. You may also need to unlock walls or doors by collecting gems.

Completing and Replaying a Level

To complete a level, you must collect all required gems and make your way to the exit portal before the time limit expires.

As you play through higher and higher levels in **FRANTIX**, the puzzles will become more complex. Successfully completing a level on your first try is an exceptional achievement; however, if you're not able to solve a level before the time limit expires or your hero perishes because of a creature or hazard, don't worry.

You can replay levels as often as you like to figure out the best and fastest way to complete them.

You may also wish to replay a level you've already solved, to get a better time. If you complete the level within the gold gem time limit, you will earn a gold gem as well! (See *Gold Gem Time Limits* — page 6).

TECHNICAL SUPPORT

NEW: To serve you better, Ubisoft is now providing full ONLINE support, to solve your gaming problems quickly and efficiently.

Simply go to <http://www.ubi.com/uk> and visit the Ubisoft Frequently Asked Questions first!

By visiting our FAQ database, you can find exactly the same answers that are available to you by calling or sending web-mail to our support representatives. This service is free and available 24/7!

If, for any reason, you do not find the answer to your question, you can click on the Ask a question link in the FAQ to send us a web-mail, ensuring that we get all the important information on your system and your problem so we can answer correctly the first time.

Make sure to include all information on your system, your problem, and the game you are playing.

If you do not have internet access, Our support representatives can assist you from 8:00 am until 10:00pm daily (excluding Bank Holidays) on Telephone: 0905 — 482 - 0109. Calls cost 30p per minute. Please be at your system when calling Ubisoft for support.

Looking for cheats to go up to the next level? Call our 24 hour automated Hints line: 0906 — 646 — 8477. Calls cost £1.00 per minute. Please ask permission from the person who pays the phone bill before making the call.

Australian Technical Support

Technical Support Info Hotline
1902 262 102

(calls are charged at \$1.98 per minute including GST.
Higher from public and mobile phones).

WARRANTY

Ubisoft guarantees to the original purchaser of this computer software product that the disc supplied with this product shall not show any default during a normal use period of ninety (90) days from the invoiced date of purchase. In the first instance, please return the faulty product to the point of purchase, together with your valid receipt. If for any reason this is not possible, (and it is within 90 days of the purchase date), then the faulty discs should be returned to Ubisoft at the below address, along with a dated receipt, location of purchase, a statement describing the fault, and all original packaging.

Address for returns:

Customer Support, Ubisoft, Chantrey Court, Minorca Road, Weybridge, Surrey, KT13 3DU

Where a CD key is required to access on-line game play, this cannot be reproduced or replaced. It is the responsibility of the original purchaser to keep this CD key secure. Lost, stolen or damaged CD keys cannot be replaced.

CUSTOMER SERVICE NUMBERS

Australia	1300 365 911*
*(Calls charged at local rate)	
Belgique/België/Belgien	011 516 406
Tarif appel local / Lokale kosten	
Česká republika	222 864 111
Po - Pa 9:00 - 17:00 Sony Czech. Tarifováno die platných telefonních sazeb. Pro další informace a případnou další pomoc kontaktujte prosím www.playstation.sony.cz nebo volejte telefonní číslo +420 222 864 111	
Danmark	70 12 7013
support@dk.playstation.com Man-fredag 18-21; Lør-søndag 18-21	
Deutschland	01805 766 977*
*(0,12 Euro/minute) Montag bis Freitag, 10.00 bis 20.0	
Ελλάδα	801 11 92000*
*Εθνική Χρέωση	
España	902 102 102
Tarifa nacional	
France	0820 31 32 33
Prix d'un appel local - ouvert du lundi au samedi	
Ireland	0818 365065
All calls charged at National Rate	
Israel	09 971170
Italia	199 116 266
Lun/Ven 8:00 - 18:30 e Sab 8:00 - 13:00: 11,88 centesimi di euro + IVA al minuto Festivi: 4,75 centesimi di euro + IVA al minuto. Telefoni cellulari secondo il piano tariffario prescelto	
Malta	23 436300
Local Rate.	
Nederland	0495 574 817
Interlokale kosten. Gesprekken kunnen voor trainingsdoeleinden worden opgenomen	
New Zealand	09 415 2447
National Rate	
Norge	81 55 09 70
0.55 NOK i startavgift og deretter 0.39 NOK pr. Minutt support@no.playstation.com Man-fredag 15-21; Lør-søndag 12-15	
Österreich	0820 44 45 40*
*(0,116 Euro/Minute)	
Россия	+7 (095) 238-3632
Portugal	707 23 23 10*
*Serviço de Atendimento ao Consumidor/Serviço Técnico	
Suisse/Schweiz/Svizzera	0848 84 00 85
Tarif appel national / Nationaler Tarif / Tariffa Nazionale	
Suomi	0600 411 911
0.79 Euro/min + pvm fi-hotline@nordiskfilm.com maanantai - perjantai 15-21	
Sverige	08 587 822 25
support@se.playstation.com Mån-Fre 15-21, Lör-söndag 12-15	
UK	08705 99 88 77
National rate. Calls may be recorded for training purposes	

Please call these Customer Service Numbers only for PSP™ Hardware Support.