

ECHELON

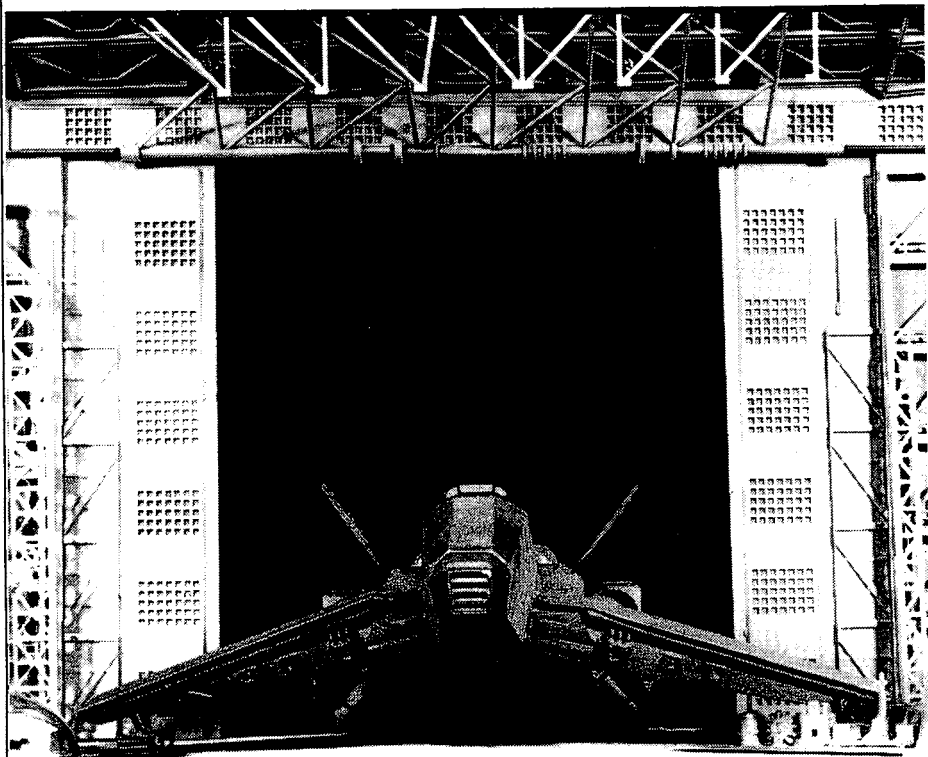

OPERATIONS MANUAL

ECHELON™ OPERATIONS MANUAL

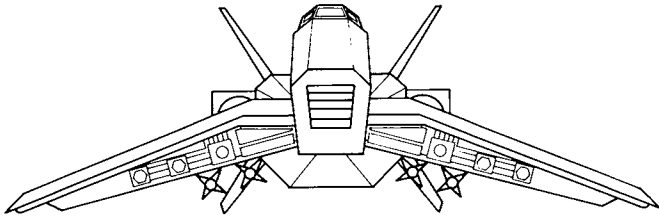

Copyright 1987
Access Software, Inc.
2561 South 1560 West
Woods Cross, Utah 84087
(801) 298-9077

CREDITS

Game Design: Brent Erickson, Roger Carver, Bruce Carver
Software Graphics: Doug Vandegrift
Writers: David Brown, Chris Jones
Data Base Layout: John Berven
Documentation: Bruce Carver, Chris Jones, Doug Vandegrift
Play Testing: Dave Ashby, David Brown, Chris Jones,
John Berven, Kevin Jones
LipStik Design: Steven Witzel, James Slade
Printing By: Printers, Inc., Salt Lake City, Utah

INTRODUCTION

Introduction..... 3

PRE-FLIGHT PREPARATIONS

Setting Up..... 4

Loading the Game..... 4

QUICK START

Crash Course..... 5

PLAYING THE GAME

Modes of Play..... 8

Your Patrol Zone..... 10

Your Base Station..... 11

Your C-104 Spacecraft..... 11

Viewing Screens..... 12

INSTRUMENTS

Instrument Panel..... 13

Instruments and What They Mean..... 15

KEYBOARD CONTROLS

Keyboard Controls..... 22

Controls and What They Do..... 23

JOYSTICK CONTROLS

Joystick Controls..... 28

WEAPONS

Weapons..... 29

LIPSTICK

The LipStik..... 30

TELEPORTER

How to Use the Teleporter..... 31

COMBAT

Combat..... 34

RPV CONTROLS

RPV Controls..... 35

Controls and What They Do..... 36

REMOTE CONTROL FLYING

Remote Control Flying..... 38

TRAINING COURSES

Training Courses..... 39

DATA LINK

The Data Link..... 40

DOCKING

Docking..... 43

HISTORY

Isis - The Tenth Planet..... 45

Statistics of Isis..... 46

Historical Time Line..... 46

MISSION

Your Mission: Classified..... 49

The Pirate Code..... 50

The Six Steps..... 50

The Six Maps..... 51

Completing Your Mission..... 52

PIRATE CODE WORKSHEET

Pirate Ciphers..... 54

CLUES

Green Map..... 55

Purple Map..... 56

Gray Map..... 57

Red Map..... 58

Blue Map..... 59

White Map..... 60

AREA INFORMATION

General Information..... 61

TROUBLE SHOOTING

Trouble Shooting Section..... 66

ACCESSORIES

Replacement Parts..... 70

Accessory Items..... 70

INTRODUCTION

Echelon is the code name for a top secret military facility located on the planet ISIS, the newest and 10th planet in our solar system. ECHELON was established by the INTERNATIONAL SPACE FEDERATION (ISF) to stop attacks on shipping and mining operations by space pirates. Only top military personnel are assigned here. The best ISF pilots will be trained to operate the 21st Century's most advanced spacecraft, the C-104 Light Cruiser, code named: *Tomahawk*. The C-104 is a patrol vessel designed for planetary exploration and combat. This spacecraft has the latest in advanced weaponry and scientific equipment.

As a top ISF pilot, you are given command of a C-104 Tomahawk and stationed in *Patrol Zone 106*. Yours is the only patrol craft in this zone and you must fly daily reconnaissance missions and search for artifacts and clues that may reveal the location of the *Space Pirate Stronghold*. Successfully completing your assignment will require top flight skills, patience and logic.

Begin by reading this manual carefully and then practice flying your new spacecraft. Try some of the training courses and become familiar with all the controls and capabilities of the ship. You can adjust the level of enemy challenge at anytime and we suggest that you start out easy and increase the level gradually as your flight skills improve.

Echelon also features the *LipStik* , voice activated control headset. We think you'll find that the LipStik gives a new dimension of realism to the game and increases player involvement to the highest level possible.

So, strap your self to your favorite chair, adjust your headset and get ready to fly into the 21st Century. **The simulation adventure of a lifetime is about to begin!**

PRE-FLIGHT PREPARATIONS

Setting Up:

1. **Keyboard Overlay:** Carefully punchout the areas marked "remove" from the sheet labeled "ECHELON CONTROL PANEL" and place it over your keyboard.
2. **LipStik:** Plug the LipStik into joystick port #2 (rear).
3. **Joystick:** Plug your joystick into joystick port #1 (front).
4. **Patrol Zone Map:** Unfold the map and place it on a table or wall near you, where it is easily seen. Although the entire zone is filled with objects, structures and things to explore, only nine areas are completely filled in on the map. We want you to explore and chart the rest of the zone.

Loading the Game:

1. Turn on your computer, monitor and disk drive.
2. Place the Echelon game disk in the disk drive and close the drive door.
3. Type: **LOAD"ECHELON",8,1** and press **RETURN**. Echelon will load and run automatically.

Authorization Check:

As the game begins you will be asked to do the following:

1. **Select fast or normal loading.** Fast loading requires that you have a 1541 or compatible disk drive.
2. **Enter Your Name:**
3. **Speak into The LipStik** for voice verification. (NOTE: If you are unable to get passed this step, your LipStik may not be working properly. Please see the *Trouble Shooting Section*. **You may bypass the voice check by adding the code "*ECH" to the end of your name.** This will also bypass the title screen.
4. **Turn the Disk Over.** After the initial loading, the back side of the disk is used for game play.

QUICK START

READ THIS FIRST!!!

If you're the cautious type, skip this section. This section is a short cut instruction course specifically designed for you *fly by the seat of your pants* pilots. Since you can't wait to get started, we'll give you enough training to get you safely out of the Docking Bay. After that, you're on your own. Once you've decided it's time to read the manual, please do so carefully and thoroughly. This game has many features and is designed to provide the player with maximum freedom and flexibility in game playing options. You may play to whatever level of action or adventure is most comfortable. Speed of play need not be a factor. Enemy spacecraft need not bother you. You decide. But because of the variety of playing modes, it is essential that you **READ THIS MANUAL THOROUGHLY** to gain the maximum enjoyment from the game.

Now for your Crash Course ...

Instruments:

Turn to page 13 and acquaint yourself with the location and meaning of all the gauges and readouts on your instrument panel.

Keyboard Controls:

Turn to page 22 and review the function of the various keyboard controls. Be sure your keyboard overlay is in place.

The C-104 Spacecraft:

This ship is the 21st Century's most advanced exploration and combat vehicle. Virtually everything on the vessel is computer controlled or monitored. It has an anti-gravity hover systems that can hold the ship in any position at any altitude. The main engines will accelerate the craft to full speed in either the forward or reverse direction in less than 6 seconds. It also has the latest in advanced weaponry.

Leaving the Base Station Docking Bay.

While holding down the button, press forward on the stick for about 2 seconds, then release both the button and the stick. (Holding down the button for approximately 1/2 second without moving the stick will stop your spacecraft.)

After you have cleared the Base Station. Press forward on the stick and then release. Your ship should now be pointing slightly downward and you should be descending slowly towards the planets surface. Your altitude readout (ALT) should be decreasing. If you get into trouble or don't understand something, **PRESS THE SPACEBAR**. This is the **EMERGENCY STOP** key.

Joystick Controls:

1. Push the stick **FORWARD** to **PITCH DOWN**.
(Point the nose of the ship down.)
2. Pull the stick **BACK** to **PITCH UP**.
(Point the nose of the ship up.)
3. Push the stick **LEFT** to turn **LEFT**.
4. Push the stick **RIGHT** to turn **RIGHT**.
5. **HOLD THE BUTTON DOWN** and push **FORWARD** to apply **FORWARD THRUST**.
6. **HOLD THE BUTTON DOWN** and pull **BACK** to apply **REVERSE THRUST**.
7. Pushing **ONLY THE BUTTON** will **STOP** your forward or reverse motion after approximately 1/2 second.
(This will not effect *HOVERING*.)

The following is a list of just a few of the things you can experience with Echelon that are outside the scope of this QUICK START section. Please refer to specific sections of the manual for instructions and playing tips.

1. Practice firing your weapons. Target ranges are located in AREAS A2 and B2. (See the ZONE MAP.)
2. Practice touch and go landings in AREA C4. (See Zone Map.)
3. Fly under the bridge in AREA B3, SECTOR K7. (Due south of your BASE STATION.)
4. Fly through the tunnel obstacle courses in AREAS B4 and A3. (See Zone Map.)
5. DEPLOY YOUR RPV with its remote camera and watch yourself fly. It's like flying a radio control plane.
6. Fly to one of the objects (solid dots on the zone map) and teleport it aboard. Please see the *Teleporting* Section. (There are over 240 objects within the zone.)
7. Request the computer DATA LINK and select the level of enemy combat you desire. When you've had enough, be sure to re-enter the DATA LINK and turn them off.
8. Try your hand at solving the PIRATE MAPS and completing the PIRATE SEQUENCE. (This is not something you can do in a few hours, but the save game feature allows you to continue play at your leisure.)
9. Explore! Simply fly, look around and teleport objects. There are hundreds of unique and intriguing structures and objects to discover and explore. Some have clues as to the location of the Space Pirate stronghold. If you find what you think is a clue, it would be wise to write it down. Once you begin your mission of solving the Pirate Maps and Sequence, you'll find some of this information extremely useful.

PLAYING THE GAME

MODES OF PLAY

Echelon simulates the controls, instrumentation and weaponry of a futuristic spacecraft. It can be played strictly as a flight simulator, exploration adventure, arcade game or as a combination of all of these. With numerous playing options, Echelon lets you make the choice.

1. *Flight Simulation* - Echelon is a true flight simulator that puts you behind the controls of a combat and exploration vehicle. The controls and 3 dimensional view will give you the thrill of real flight. Fly and land anywhere inside the Patrol Zone. You'll find challenge and satisfaction in mastering the instrumentation, weaponry and controls. There's also a great feature that allows you to fly by 'remote control'. Using your RPV, you can control and view your spacecraft from 'outside' by using the *Automatic Tracking System*. It's like flying a remote control aircraft.

2. *Arcade Action* - Once you are comfortable with the controls, you may want to try your skills against enemy spacecraft. There are **SIX DIFFERENT LEVELS OF ENEMY STRENGTH** varying from **none at all** to **very heavy**. This allows you to increase the level of difficulty as your skills improve. The computer keeps track of your success by awarding you combat points. In addition, there are five different training courses which are designed to improve your skills in maneuvering the spacecraft, selecting weapons and object retrieval. On many of the courses, you can compete against the clock to add excitement and intensity.

Exploration Mystery and Adventure

Echelon offers the mental challenge and stimulation of an adventure game without the aggravation and frustration of sending a player to predetermined paths and locations. Because Echelon is a simulator, a player can choose to fly anywhere inside the Patrol Zone. If you take the assignment of locating the Pirate Base, it will take time, patience and logic. But reaching the solution will be more like 'real life' because the answers will not be determined by following programmed paths.

Operating Classifications:

There are three general classifications for operation of your spacecraft.

1. *Scientific*: Exploration and training without engaging enemy aircraft. (This is the normal Echelon Playing level.)

2. *Patrol*: Encounter mild resistance from enemy spacecraft while exploring the unknown. To activate this level of play do the following:

- 1- Press the DATA LINK KEY
- 2- Press '2' (GAME OPTIONS)
- 3- Press '1' (COMBAT)
- 4- Press '1' (ENEMY STRENGTH)
- 5- Press '2' or '3' (VERY LIGHT OR LIGHT)
- 6- Press 'X' (TERMINATE)

3. *Military*: For non-stop enemy attacks follow the steps outlined above for *PATROL* except in step (5) choose:

'4' Medium or '5' Heavy or '6' VERY HEAVY

You may change classifications at any time, simply by re-entering the DATA LINK.

To return to *Scientific Class*, follow the same steps for the *Patrol Class* except in step '5' select '1' No Enemies.

Your Patrol Zone:

The ZONE is a partially explored region of the planet ISIS that is 840 kilometers square. Within the ZONE are 36 smaller regions called AREAS (6 rows x 6 columns).

Each AREA is 140 kilometers square and is also sub-divided into smaller regions (14 rows x 14 columns). They are called SECTORS and each is 10,000 meters square. There are 196 sectors in each AREA.

The figure below graphically represents the ZONE with both AREA and SECTOR sub-divisions.

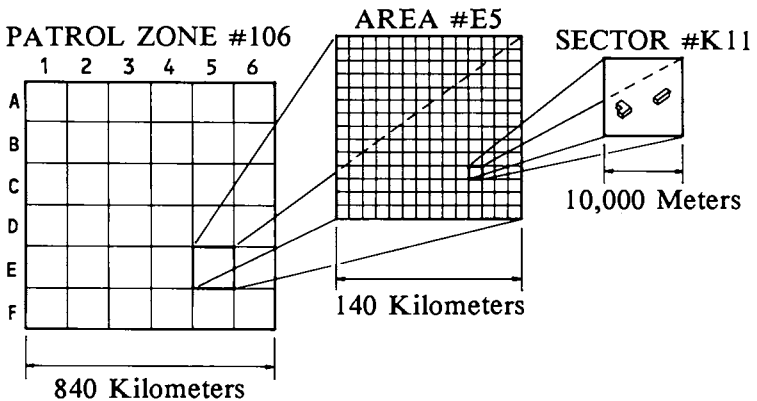

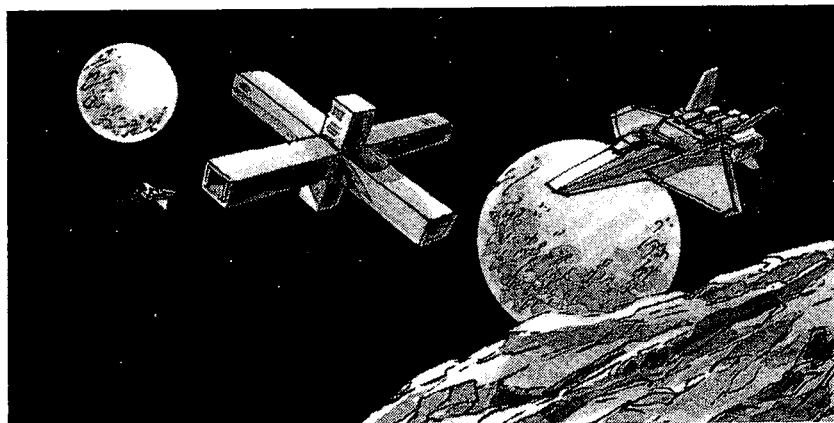

YOUR BASE STATION:

Your base of operations is a fully equipped orbiting **BASE STATION**. The **STATION** is located in **AREA B3, SECTOR G7** at altitude 10,000 meters. The orbit is geosynchronous so that the **BASE** will always remain in a fixed location. You must return here to **DOCK** your spacecraft and receive more munitions or fuel or to repair any damage. (Also see **DOCKING**.)

YOUR C-104 SPACECRAFT:

This ship is state of the art technology in a space exploration and combat vehicle. Your craft is equipped with twin laser fusion drive engines and three 100 ton magnetic flux generators. Two of these generators power the anti-gravity hover system while the third unit powers the shield defense envelope. The fusion drive engines use deuterium pellets for fuel and are capable of delivering 2 million pounds each of forward or reverse thrust.

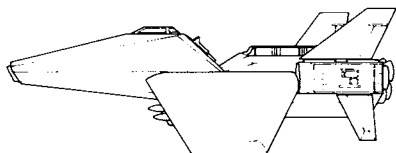

VIEWING SCREENS

This vessel is completely computer monitored and controlled. Information from the infrared and microwave scanners are fed to the computer for interpretation. The computer then displays this information on two viewing screens. **THE MAIN SCREEN** shows 'point of view' images of building, vehicles, terrain, etc. This screen will also display a blue grid which indicates the planet's surface. You can selectively shut off all or part of the surface grid. This is normally done to increase the rate at which the display is updated.

The smaller screen is the **TOP VIEW** or overhead view. This is the computer's interpretation of an outside view looking down on your spacecraft.

Your ship is represented in outline form as 7 flashing dots. The dot in the center locates the center of your spacecraft. The green vertical and horizontal lines represent sector boundaries, the **TOP VIEW** can be turned on or off as needed by pressing the **TOP VIEW** on/off key. Again, this is normally done to increase the rate at which the main screen is updated.

NOTE: When the **RPV** view is selected, both screens will display images from the **RPV's** point of view.

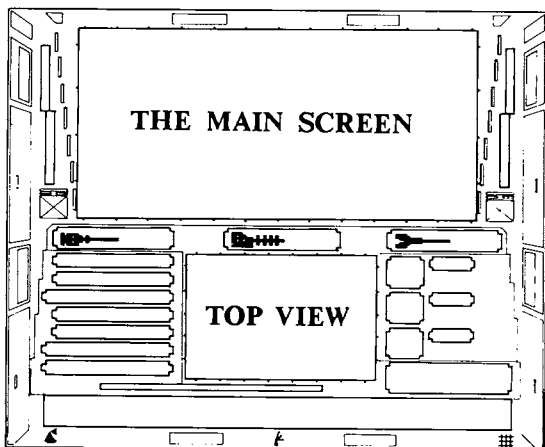

INSTRUMENT PANEL

Stop your ship and review your instruments on your monitor as you read this page carefully. Being able to fly with only your instruments may someday save your life.

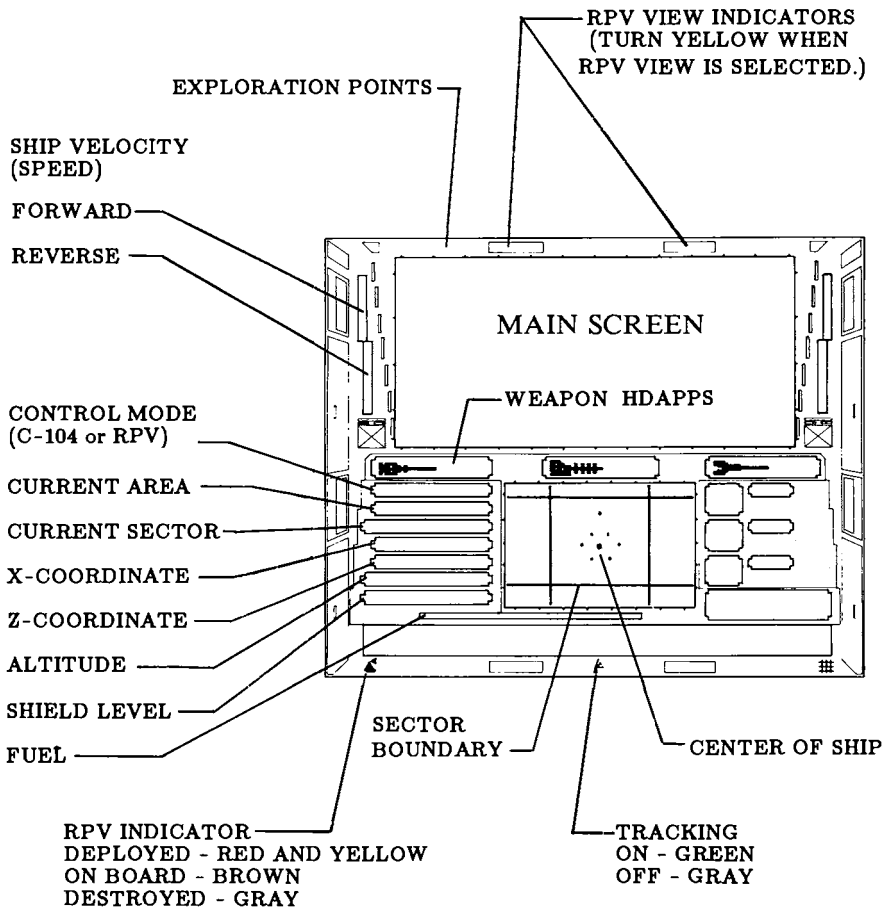

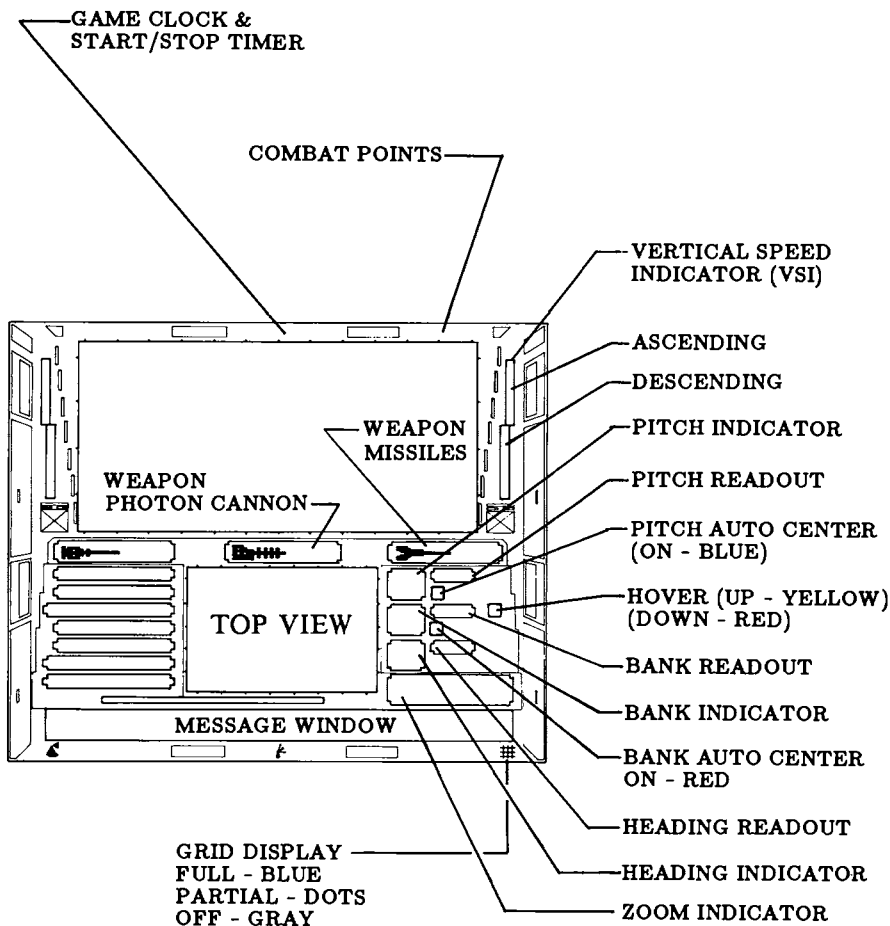

THE INSTRUMENTS AND WHAT THEY MEAN

HEADING:

Heading refers to the direction your ship is pointing relative to due north. The heading readout is located next to the heading indicator. The reading is given in degrees (0 thru 359) with North = 0.

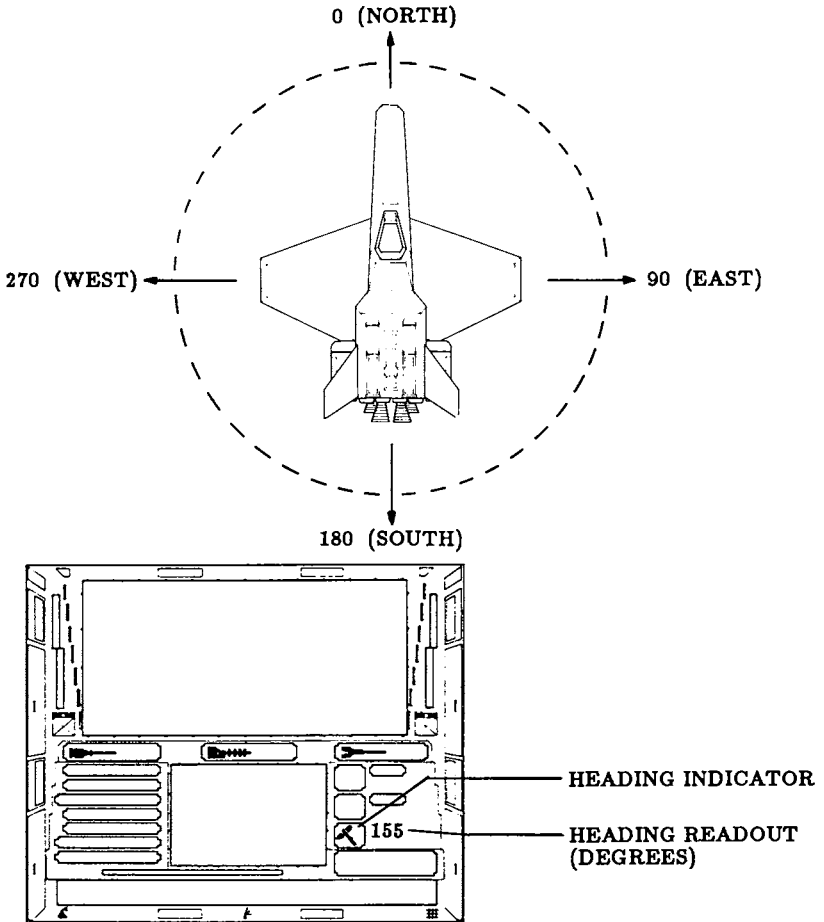

You may change your heading (the direction you are pointing) by turning the ship. This is done by pushing LEFT or RIGHT on the joystick.

BANK:

Bank refers to the angle of TILT of the wings of your spacecraft. As you turn, your ship will automatically bank.

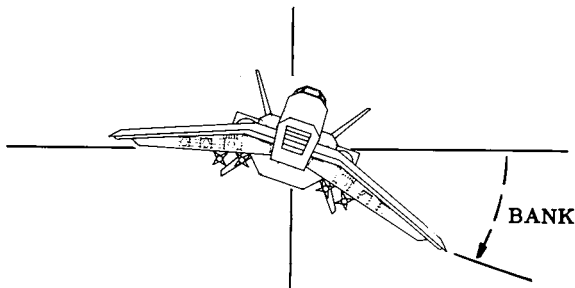

Maximum Bank is 45 . Pushing LEFT or RIGHT on the stick, will BANK (tilt) as well as TURN (change the heading) of your ship. When you release the stick, the BANK will automatically return to ZERO (level flight). This is referred to as BANK AUTO CENTERING (B.A.C.). You can toggle the BAC feature on or off by pressing the 'A' key. We recommend that inexperienced pilots leave BAC on however.

The BANK reading is displayed next to the BANK indicator and shows plus or minus degrees from level flight (Bank = 0)

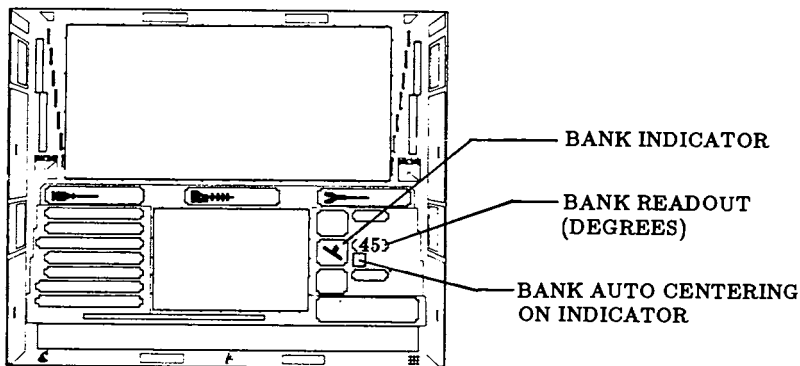

PITCH:

Pitch refers to the attitude of the nose of the spacecraft. When the ship is **PITCHED UP** the **NOSE WILL BE UP**. If the **PITCH IS DOWN** the **NOSE WILL BE DOWN**. **PITCH** is controlled by pressing **FORWARD** or **BACK** on the joystick. Pressing **FORWARD** will push the nose down. Pulling **BACK** will pull the nose up.

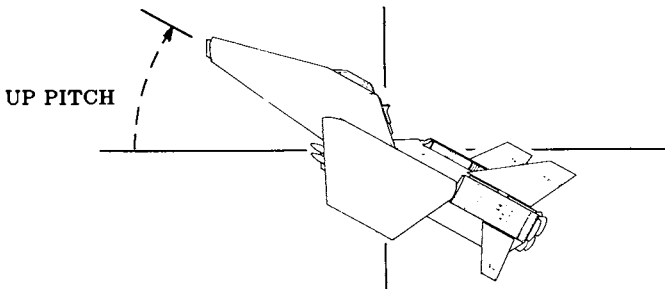

When you are stopped, it is perfectly safe to change your pitch to any angle between full up (+90) to full down (-90). This is especially useful during close exploration maneuvering. During flight however (moving forward or backward), it is important to control your pitch. Your main engines will always move the ship in the **DIRECTION IT IS POINTING**. Therefore, if your nose is pointing down and you are moving forward, you will eventually hit the ground.

The **PITCH** reading is displayed next to the **PITCH** indicator and shows plus or minus degrees from level flight (Pitch = 0).

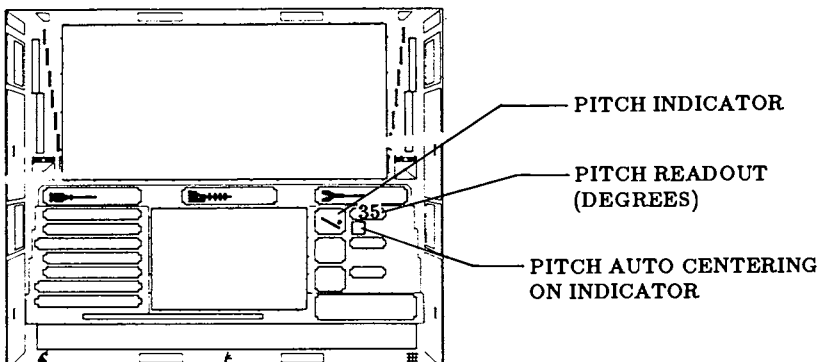

There is a PITCH AUTO CENTERING (PAC) system that will try to maintain Pitch = 0 (level flight). You can selectively turn PAC on or off by pressing the RETURN key.

COORDINATE SYSTEM:

Your current location within the Zone is always defined in terms of AREA, SECTOR, and then coordinates and altitude within the sector. Since each sector is 10,000 meters across, coordinates are given as follows:

X Coordinate = 0 thru 10,000 (west to east)

Z Coordinate = 0 thru 10,000 (south to north)

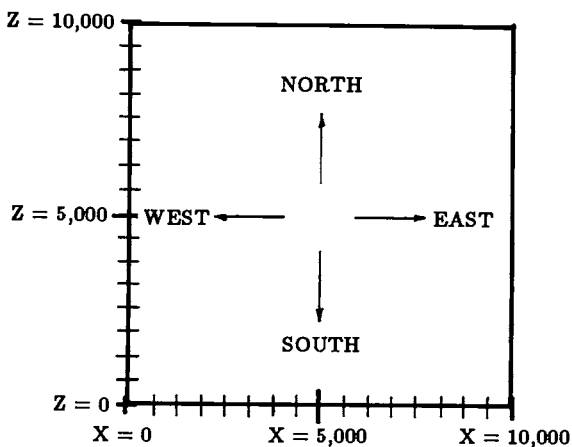

Your altitude will range from 0 at the planet's surface to a maximum of 13,500 meters. Your ship's computer will not allow you to leave the zone or to fly above 13,500 meters without special authorization.

AREA, SECTOR, COORDINATE AND ALTITUDE READOUTS are located on your main instrument panel as shown below.

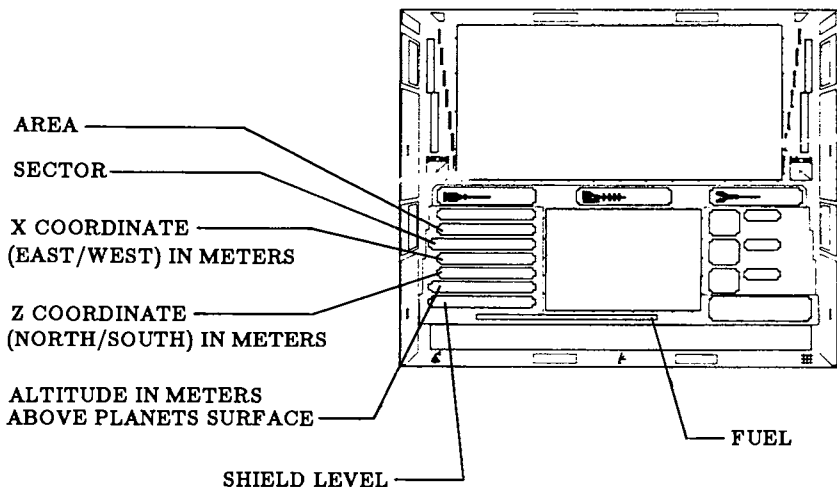

SHIELD INDICATOR:

The shield indicator displays the amount of energy available to the Shield Defense Envelope. Direct hits from enemy weapons and striking the ground at high velocities will gradually deplete your shield energy. Once the shields are depleted you are very vulnerable to severe damage. Return to BASE immediately and dock your ship to recharge your shields and repair any damage.

FUEL GAUGE:

This indicates the amount of deuterium fuel remaining to power the main engines. Running out of fuel will end the game.

VELOCITY (SPEED) INDICATORS:

There are two sets of velocity indicators on your instrument panel. The display on the left indicates forward or reverse velocity. Forward velocity is shown in yellow and reverse velocity is shown in red.

The display on the right is the vertical speed indicator (VSI) and shows the rate of climb or descent. When the indicator is yellow your ship is climbing and when red, your ship is descending. Rate of climb or descent while hovering is also shown on the VSI.

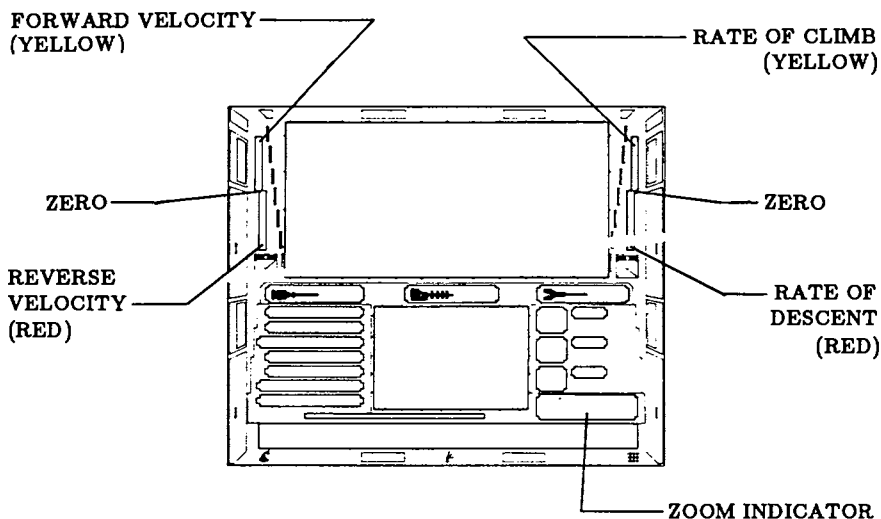

ZOOM INDICATOR:

Both the MAIN and TOP VIEW screens have zoom (magnification) capabilities. When one of the **ZOOM IN OR OUT KEYS ARE PRESSED**, these indicators will show the amount of magnification being used. Main screen zoom has a range of 1X normal to 16X maximum. TOP VIEW has a range of 1X normal to 22X maximum.

GAME CLOCK:

The Game Clock keeps track of total time of play. It is saved along with a saved game so that total running time is preserved. Even when the STOP WATCH TIMER feature is selected, the GAME CLOCK continues to run.

RPV INDICATOR:

This indicator will indicate the current status of your RPV (Droid).

Yellow & Red = RPV is Deployed

Brown = RPV is Onboard

Gray = RPV was Destroyed

If your RPV was destroyed, you must return to base and dock to receive a replacement Droid.

TRACKING ON INDICATOR:

This indicator will turn green when RPV tracking is On.

RPV VIEW INDICATORS:

If these console lights are yellow, they indicate that the main screen is now displaying the VIEW from the RPV camera. If lights are black, the MAIN SCREEN is displaying the view from the C-104.

GRID ON INDICATOR:

The computer generated surface grid may be set to FULL, PARTIAL or OFF. This indicator will show the current status of the grid display.

SCORING INDICATORS:

There are two separate scoring displays. The left display is the 'E' or EXPLORATION score. Points are awarded here based on credits received through artifact and clue retrieval. The right display is the 'C' or COMBAT score. Points are awarded here based on enemy ships destroyed. You are also awarded combat points for target practice and combat simulation. Virtually any structure or terrain or the planet can be a target. However, the ship's computer will not allow you to destroy structures that are

not hostile. If you fire at a non-hostile target, the computer will simulate the sequence on screen. If the target was hit the image will be removed from the screen and points will be awarded.

MESSAGE WINDOW:

Messages and instructions will appear from time to time in this window. Follow the instructions when they are given.

KEYBOARD CONTROLS

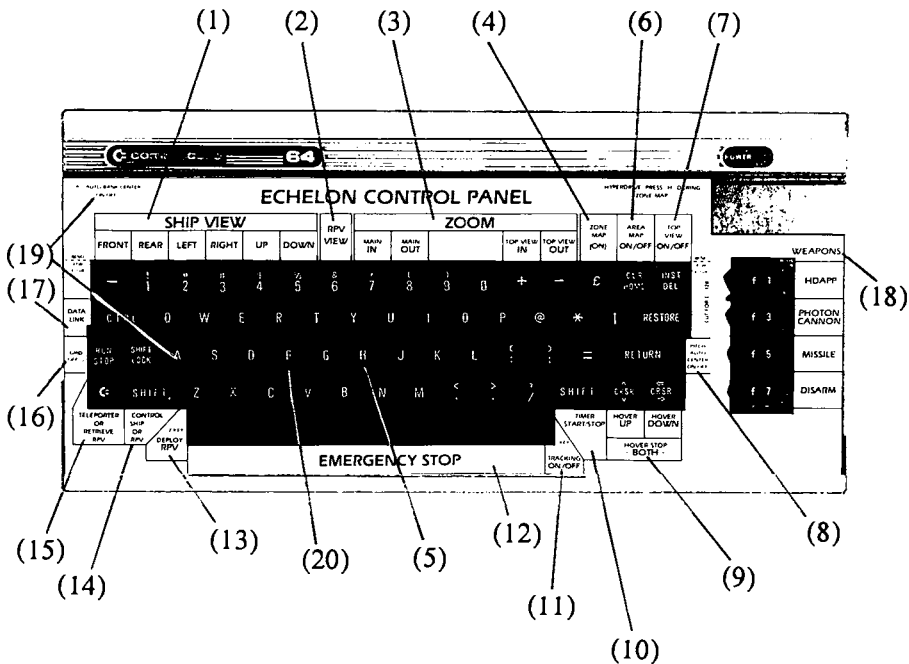

KEYBOARD CONTROLS AND WHAT THEY DO

1) *SHIP VIEW*

(←,1,2,3,4,5)

Select front, rear, left, right, up, or down. All views except the front view will display a portion of the spacecraft to indicate which view is currently selected. CAUTION: Do not mistake the DOWN VIEW'S teleport sight for weapon cross hairs.

2) *RPV VIEW*

('6' key)

When your RPV is deployed, you can switch to RPV VIEW at any time. When this is down the 'RPV VIEW' lights on the instrument panel will turn yellow. One of the more interesting features of the game is flying the C-104 while watching from the droid (RPV). Be sure and use the tracking feature described below.

To switch back to ship view, simply select one of the 6 ship view keys described above.

3) *ZOOM*

(7 & 8 Keys) (+ & - Keys)

Both the MAIN SCREEN and the TOP VIEW have Zoom (magnification) capabilities. The Zoom feature allows you to examine buildings and structures more closely without flying nearer to them. The Zoom magnifies the viewing area to make objects appear closer. The main screen can be 'Zoomed In' to a power of 16X while the TOP VIEW can be zoomed into 22X. Be careful not to forget that you have zoom in effect. It can be very disorienting.

4) *Zone Map*

('E' Key)

Pressing this key will bring up the ZONE MAP which is divided into 36 Areas. When you begin the game the entire map will be red (except at the Base Station). As you fly around the map will turn white in the sectors that have been scanned by your ship's sensors. Your present location is always indicated by a flashing dot. If you SAVE your games periodically, you will always be able to see where you have been by calling up the ZONE MAP. Press the 'Space Bar' or say 'Continue' into the LipStik to return to the main screen.

5) *HYPERDRIVE*

('H' Key During Zone Map)

There will be times when you will want to move quickly across the Zone. You could fly to your destination Area using your main engines, but it would waste time and fuel. Hyperdrive will transport you there in a matter of seconds. **TO USE THE HYPERDRIVE FEATURE, FIRST SELECT ZONE MAP**, then press the 'H' key. A flashing arrow will appear at your current position. **MOVE THE JOYSTICK UP, DOWN, LEFT OR RIGHT** and position the arrow in the destination area. Now **PRESS THE BUTTON** or the **SPACE BAR**. Within a few seconds you will arrive in the new area. Your Sector and coordinates will remain unchanged.

6) *AREA MAP*

(Clr/Home Key)

The area map will displayed your current location within the area. Unlike the Zone Map (which freezes play), the AREA map is a 'HEADS UP' display and can be toggled on and off without stopping play. 'Toggle' means that pressing the key once will turn the map on, pressing the key again will turn it off.

7) *TOP VIEW*

(Inst/Del Key)

This key is used to toggle the TOP VIEW on and off. Turning the top view off is normally done to speed up the rate at which the main screen updates.

8) *PITCH AUTO CENTER*

(Return Key)

Pressing this key toggles the Pitch Auto Centering feature on and off. When auto centering is on, the blue light just below the Pitch readout will come on. This feature will automatically return your pitch to Zero (level flight) when the joystick is released.

9) *HOVER*

(Cursor Keys)

These keys control the anti-gravity hover system. Push the HOVER DOWN key to make your ship DESCEND. Push the HOVER UP key to make it ASCEND. The longer you hold the key down, the faster the ship will move. PRESS BOTH KEYS AT ONCE TO STOP. The EMERGENCY STOP key will also stop your hover velocity as well as any forward or reverse velocity.

10) *TIMER*

(Right Shift Key)

This key is used to engage the Start/Stop Timer (stop watch). PRESS ONCE to START the timer, PRESS AGAIN TO STOP the timer, PRESS AGAIN to return to the GAME CLOCK. Use this timer to time yourself through the various training courses. Try competing against your friends.

11) *TRACKING*

('/' Key)

Push this key to toggle the RPV tracking system on or off. When your RPV is deployed, it will try to follow your ship at all times if the TRACKING IS ENABLED. The tracking indicator (see instrument panel) will turn green when tracking is ON.

12) *EMERGENCY STOP*

(Space Bar)

This key will zero all ship velocities. The on board computer will recognize this key as an emergency condition and bring your ship to a stop as quickly as possible.

13) *DEPLOY RPV*

('Z' Key)

Press the key to deploy your RPV. This droid is used only for exploration and reconnaissance as it has no weapons. You can activate its camera and sensors by selecting RPV VIEW ('6' Key). When the droid is out of the ship (deployed) the RPV indicator will turn yellow and red. Shield energy for your droid is microwaved from the C-104. BE CAREFUL not to touch the ship and droid when the shields are energized or the RPV WILL BE DESTROYED. To bring it back on board you must use the teleporter. If you inadvertently destroy the RPV, you must dock to receive a replacement.

14) *CONTROL*

(Lt. Shift)

This key will toggle between C-104 control and RPV control. By switching to RPV CONTROL and RPV VIEW you can control the droid very much like the C-104. The RPV does not have multiple viewing directions or weapons and it does not bank when turning. The unit that is being controlled is displayed on the instrument panel just above the AREA indicator. ALL INSTRUMENTS AND READOUTS PERTAIN TO THE UNIT BEING CONTROLLED. The droid must remain in the same area as the C-104.

15) *TELEPORTER*

(Commodore Key)

Pressing this key will engage the OBJECT TELEPORTATION SYSTEM. Several conditions must be met before an object can be beamed aboard. All engines including hover must be stopped. ALTITUDE must be at 50 meters or below and down view must be selected. In addition, there must be an object (flashing hour glass) visible on the main screen.

The teleporter is also used to retrieve the RPV. Since droid coordinates are always known, the only requirement is that your velocities be ZERO. See the *Teleporter* Section.

16) *GRID*

(Run/Stop)

This key is used to select full, partial or no surface grid. The grid is generated by the on board computer to represent the planet's surface. Turning off the grid will increase the rate at which the main screen updates. This can be especially useful when battling enemy spacecraft. Repeatedly pressing the key will switch from FULL to PARTIAL to OFF and back to FULL.

17) *DATA LINK*

(CTRL Key)

Pressing this key will link your on board computer to the main computers at ECHELON HEADQUARTERS. Once the data link is established, you can select numerous playing options, review the pirate maps, load or save a game, or even adjust the sound filters for optimum effect. See the DATA LINK SECTION for more information.

18) *WEAPONS*

(F1, F3, F5) (F7)

These four keys are used to arm and disarm the weapon systems aboard the C-104 spacecraft. Select 'F1' to arm the HDAPPS, 'F3' to arm the PHOTON CANNONS, and 'F5' to arm the MISSILES. Select 'F7' to disarm all weapons. See the WEAPONS SECTION for more information.

19) *AUTO BANK CENTER*

('A' Key)

Pressing the 'A' key will toggle the AUTO BANK CENTERING FUNCTION on and off. When activated, the small red light near the bank indicator will come on. (See Instrument Panel.) In the 'ON' mode (which is normal) the bank or tilt of the wings will automatically return to zero (level flight) when the joystick is released.

20) *FIRE KEY*

('F' Key)

Firing of weapons is normally done by using the LipStik. The 'F' key is provided as a backup system in the event your LipStik is damaged or lost. The disadvantage of using the key is that your hands must leave the stick in order to fire. This is a real handicap during high speed target runs or enemy dog fights.

JOYSTICK CONTROLS

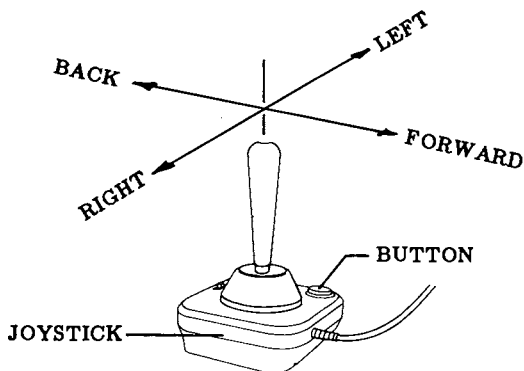

FORWARD ONLY = PITCH DOWNWARD (NOSE DOWN)

BACK ONLY = PITCH UPWARD (NOSE UP)

LEFT = BANK AND TURN LEFT

RIGHT = BANK AND TURN RIGHT

FORWARD + BUTTON = ACCELERATE (FORWARD THRUST)

BACK + BUTTON = DECELERATE (REVERSE THRUST)

BUTTON ONLY FOR APPROXIMATELY 1/2 SECOND = STOP

(NOTE: THIS WILL NOT STOP HOVER)

Your main engines will move your ship forward or reverse in the direction you are pointing. Remember to keep an eye on your Pitch Indicator or you may find yourself flying straight into the ground.

To apply FORWARD THRUST, hold down the BUTTON and push FORWARD on the JOYSTICK. Your ship will begin to accelerate. Once you have reached a comfortable speed, **RELEASE BOTH THE BUTTON AND THE STICK AT THE SAME TIME.** When you wish to stop any forward or reverse motion, simply **HOLD DOWN THE BUTTON** without pushing on the stick. The ship's computer will interpret a 'BUTTON ONLY' input from the joystick as a 'STOP MAIN ENGINES COMMAND'.

Applying **REVERSE THRUST** is simply a matter of simultaneously pressing the **BUTTON** and **PULLING BACK** on the stick.

REMEMBER that pushing or pulling on the stick without the button will change the **PITCH** of your spacecraft, and pushing the button without moving the stick will **STOP** your main engines. It is therefore important to always **PUSH THE BUTTON AND STICK AT THE SAME TIME, IF YOU WISH TO CHANGE THE SPEED OF YOUR SHIP.**

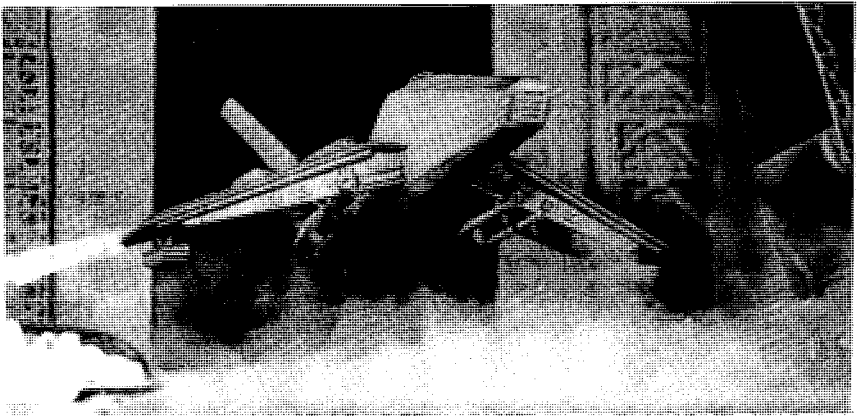

WEAPONS:

HDAPP: (High Density Anti-Proton Projectile): These anti-matter packets are suspended in a magnetic field until fired. Once released, they disintegrate rapidly but are very effective at short range (up to 1800 meters).

PHOTON CANNON: This unit is basically a very high intensity pulse laser. The pulse power is supplied by rapidly discharging a P.C. power cell and the cell casing is ejected after each round is fired. The cannons are good at short to medium range (up to 4600 meters).

MISSILES: These are medium to long range, solid fuel rockets with micro-nuclear detonators. (Acronym: LRN) They have no external guidance system which virtually neutralizes any electronic counter measure techniques (effective range 6300 meters).

THE LIPSTIK

The LipStik was specifically designed for ECHELON because of The weapons were originally designed to *fire* using the "F" key. However, we found that it was difficult to chase enemy ships or to zero in ground targets effectively while constantly releasing the stick and reaching for the keyboard. We decided to design a separate *fire button* that didn't require the use of your hands. The LipStik was born! When we tested the first prototypes, we discovered something very interesting. Not only did the headset provide the desired *extra button*, but it added a whole new feeling of power and control that wasn't there with the joystick alone. Because the feeling was so unique and so satisfying, we immediately designed a version to work in parallel with an existing joystick button. This version, called *The LipStik Plus*, adds the same feeling to any other game old or new that utilizes a joystick button. Both **The LipStik** and **The LipStik Plus** utilize voice activation *not* voice recognition. This is like a voice switch or voice button. Any word or sound you make will activate The LipStik and fire your weapons (if they're armed). Even blowing directly into the mouthpiece will make it switch.*

Because The LipStik has to be quite sensitive to react quickly, it may also present problems when you want to talk or laugh instead of firing. **The weapons cannot be disarmed while you are firing or while a missile or shell is still on screen.** If you are having trouble with the weapons firing inadvertently, try turning the mouthpiece up or down away from your mouth when you are not firing.

During the game you may be asked to speak letters or numbers into the LipStik. When you do so, speak clearly and pause between each word.

If you experience problems with the LipStik, refer to the *Trouble Shooting Section*.

***NOTE:** Purposely blowing into the mouthpiece is not recommended, as it may deform the internal diaphragm in the microphone. This would cause the unit to 'fire' continuously. If you must blow, turn the mouthpiece sideways and blow across the microphone.

HOW TO USE THE TELEPORTER

One of the most important functions of your spacecraft is teleporting objects aboard. There are hundreds of objects in the Patrol Zone that contain information needed to solve the maps and locate the Pirate Base. The RPV is also retrieved by the teleporter. To teleport objects, use the following procedure:

1. *Locate an Object -*

Objects that are teleportable are shown as flashing hourglasses on the viewing screen. From a distance the object appears as a small flashing dot.

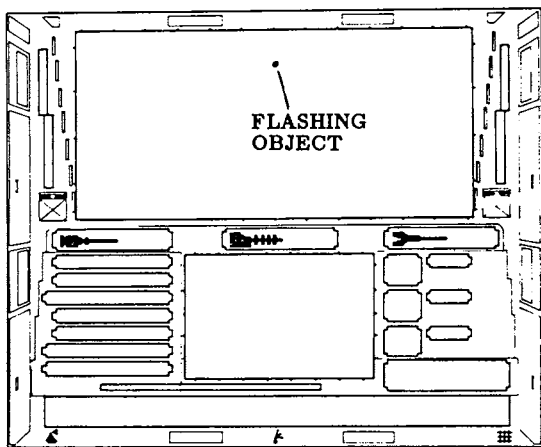

NOTE: (To follow this procedure while attempting to teleport an actual object, fly to Area B-2, Sector J-7.)

2. Approach -

When an object appears on screen, it may be in the adjacent sector. Fly towards the object and adjust your controls so that the object remains in the center of the screen. When your spacecraft gets close, the object will begin moving more rapidly. Lower your speed and altitude and continue your approach. If the spacecraft continues forward when you are very near the object, it may disappear from the front view as the spacecraft begins to pass over it.

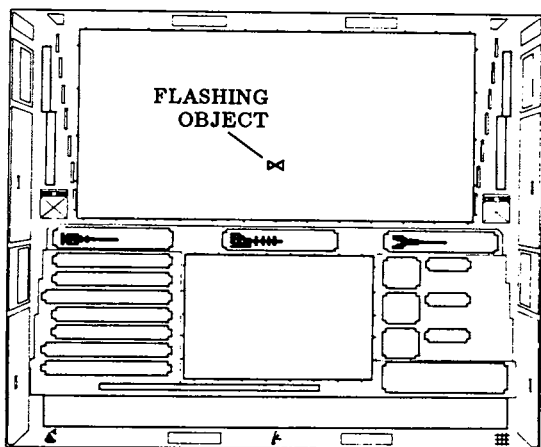

3. Activate 'Down' Screen -

To teleport an object, your spacecraft must be directly over it. Press the *down view* key to activate the down screen. The down screen shows the view directly below your spacecraft. There is a blind spot between front and down view screens and when the object passes out of view from the front screen, it is not immediately seen in the down screen.

4. *Maneuver Your Spacecraft Over The Object -*

If the object is in front of your craft, begin moving slowly forward so that the spacecraft passes over the object. The object should now be visible on the *down* screen. If the object passes outside the *down* view area, use the other views from the ship to locate the object again. Use the down view teleport sight (small cross hairs) to line up the object. Maneuver the spacecraft so that the object is still partially visible when you are at or below 50 meters.

NOTE: Objects cannot be teleported unless your altitude is 50 meters or below.

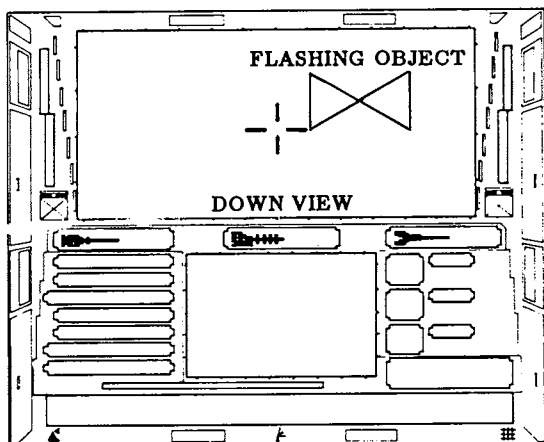

5. *Begin Teleportation Sequence -*

Once the object is within teleport range (inside the screen area with the spacecraft below 50 meters) press the *Teleport Key*. This will activate the teleport sequence and bring the object on board. If the object is not properly lined up, the message "*No object within range*" will appear. This means either your craft is too high (over alt. 50) or not enough of the object is inside the screen area. Make the proper adjustments and try again.

NOTE: To help you get started, the Patrol Zone map included with Echelon shows the location of all the objects within 9 of the 36 areas. Most objects located throughout the Patrol Zone can be found near buildings and structures. *Remember:* There are over 240 objects within the zone.

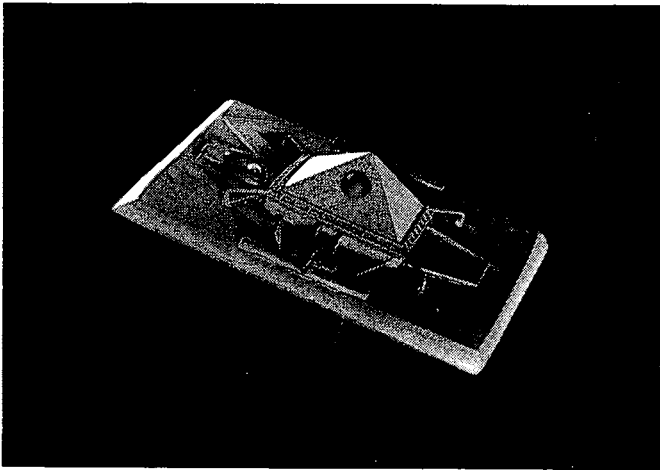

COMBAT

If you wish to battle enemy spacecraft, enter the DATA LINK COMBAT SECTION and set enemy strength to a value other than 1.

The planet is broken down into a number of Patrol Zones. Since there is only one C-104 per zone, it's up to you to defend it. When your ship comes under attack, a small audio signal will sound. Enemy spacecraft should be visible on the 'top view' screen. They will be identified as small dots moving toward your spacecraft. Activate one of your weapons by pressing F1, F3 or F5, adjust your headset and get ready for combat.

The only direction your weapons fire is directly ahead. Look at the *top view screen* and identify which of the enemy spacecraft is the closest and position your spacecraft to view the approach from the *front screen*. Try not to oversteer. When the craft is within range, speak into the LipStik or use the 'F' key to fire your weapon. Each time an enemy spacecraft is shot down points will be awarded. These will appear on the upper right hand portion of the Instrument Panel. You are awarded significantly greater points for chasing down an escaping enemy ship than one that is coming towards you.

RPV CONTROLS

The RPV is a remote piloted vehicle and is used for all types of exploration and observation work outside the spacecraft. The RPV has its own propulsion system and can fly in much the same manner as the C-104. It also has a camera that allows the pilot to monitor the RPV's viewing area. To deploy the RPV, the C-104 must be at alt. 00. Once on the ground, press the 'Z' key. A message and the small figure in the lower left corner of the panel will change color. The RPV will always be deployed to the north of you. When your spacecraft is on the ground at heading 00, the RPV will be visible on the front screen.

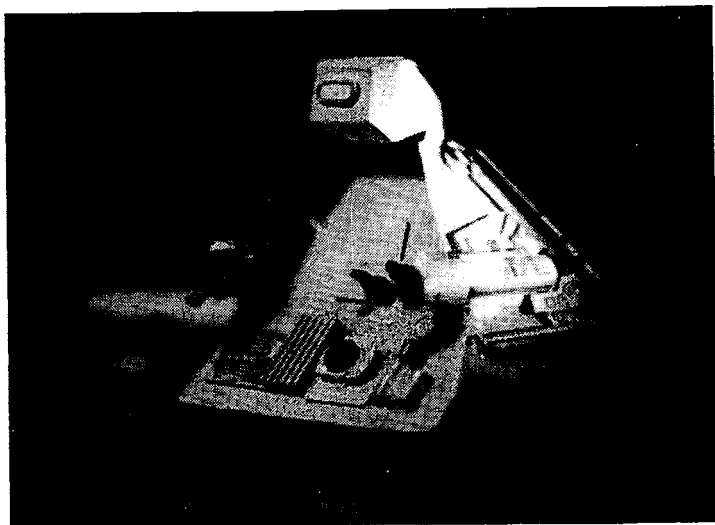

The RPV is operated by using the same controls that are used with the C-104. To switch the controls from the C-104 to the RPV, press the 'CONTROL SHIP OR RPV' key. The control indicator just above the 'AREA' indicator should now read RPV. (When control is switched back to the C-104, the indicator will read 'C-104'.)

To switch to RPV view, press the RPV view key. If you have not moved the RPV from where it was deployed, you will see the *outside* view of your spacecraft. To switch the view back to the C-104, press one of the *Ship View* keys.

You can use the RPV to explore buildings and structures or to fly around the sectors. The RPV responds to the controls in the same manner as the C-104. Be careful when operating the RPV near the spacecraft. If they collide, the RPV will be destroyed.

If your RPV is destroyed and you wish to obtain a new one, return to the *Base Station*. When you dock you will automatically receive a new one. To retrieve your RPV after deployment, the C-104 must be in control and you must be stopped. Press the *Teleport* key to teleport the RPV aboard.

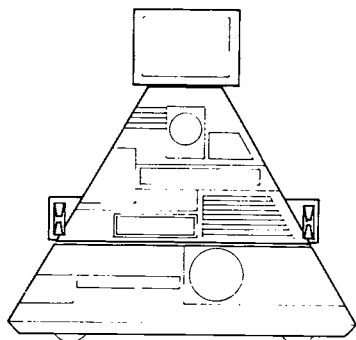
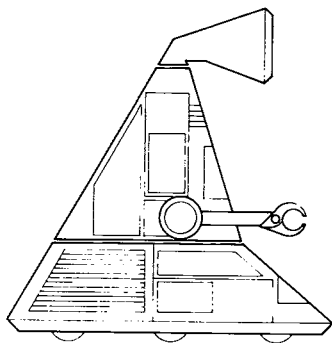

SWITCHING CONTROLS

Switching the controls between the C-104 and the RPV can sometimes be confusing. When the control indicator reads C-104, the instruments pertain to the C-104. If the control indicator reads *RPV*, then the instruments pertain to the RPV. Watch the instrument panel and switch the controls back and forth between C-104 and RPV. Each time you switch, the information displayed changes as well.

When one of the 6 ship view keys is selected the top view shows the spacecraft as 7 flashing dots with one flashing dot in the center. If the RPV is deployed it is shown as a single yellow non-flashing dot. The C-104 is always in the center of the screen when a C-104 view is selected.

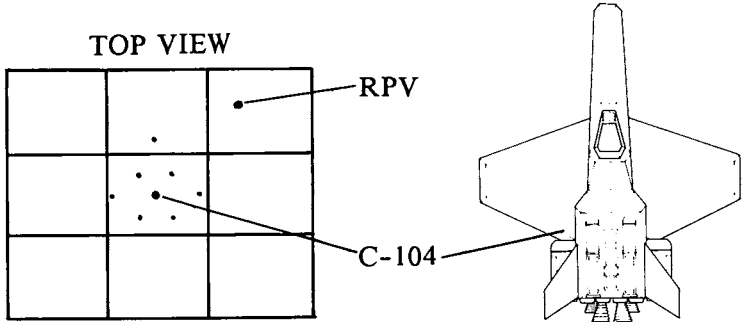

When the view is switched to the RPV, it is shown by the 4 flashing dots in the form of an arrow. The C-104 is now shown as a single dot, and the RPV becomes the center of the *Top View Screen*.

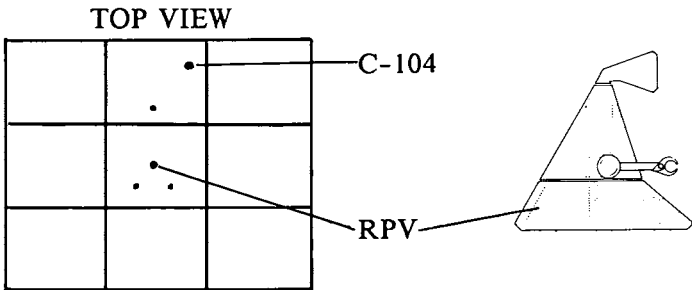

REMOTE CONTROL FLYING

The *tracking function* allows you to fly the C-104 like a remote control aircraft. To try this, do the following:

1. Set your altitude at 00
2. Deploy your RPV
3. Switch to RPV view (key 6). You should now see the C-104 directly in front of you.
4. Switch the controls to the C-104 (left 'shift' key)
5. Press the *TRACKING KEY* (press the '/' key)

With the tracking on, the RPV will follow the C-104's flight pattern.

To start, try something simple - Use the **HOVER UP** key and take the C-104 to an altitude of 250 meters. You'll notice as you fly that the RPV will continually change its view angle to keep the C-104 on screen.

Now rotate the C-104 by changing the heading. Slowly fly a circle pattern around the sector. Notice on the top view that the RPV will follow the your movement by pointing directly at the C-104.

When you're ready to fly further away from the RPV, periodically look at the top view to identify where the spacecraft is in relation to the RPV. We recommend using magnification 04x for most remote flying. As the spacecraft gets closer to the RPV, decrease the zoom. Also, if the C-104 gets off screen, decrease the zoom.

Because you're viewing from outside the spacecraft, the exact direction you're flying can be confusing. Check the heading to make sure you're going in the right direction.

By using the tracking you can watch the C-104 bank, turn and *fly* by your position. Try setting the RPV by a bridge and watch the C-104 fly under it.

If you get disoriented or lose track of your position, simply stop

the C-104, switch to front view and press the *Teleport Key*. Your lost droid will be beamed aboard.

NOTE: The C-104 and the RPV must always remain in the same AREA. You will not be able to fly the droid outside of the AREA, and if you attempt to fly across an AREA boundary with the RPV deployed, the teleporter will automatically engage and beam it aboard.

TRAINING COURSES

There are six different flight training courses designed to improve your skills in flying and operating the spacecraft.

1. *Touch and Go:* The object of the touch and go course is to set your spacecraft down on landing pads that are located in Area C-7, Sectors H-6 through H-10. Start on the arrow (--->) located in Sector H-5 and at altitude 200. The landing pads are small yellow squares with a red X inside. They are located in the sectors directly east. Begin moving forward and try to set your spacecraft directly on top of the landing pad. This requires using the down screen view. Positioning your spacecraft over the landing pads is very similar to positioning your ship over teleportable objects. This course will help improve your teleporting skills. Use the *Timer* to see how fast you can run the course.

2. *Ground Tunnel Obstacle Course:* One of the keys to maneuvering your spacecraft is to avoid over 'steering'. The ground tunnel obstacle course is located in area B-4 and starts in Sectors F-4. You are required to fly your spacecraft through the tunnel and avoid flying through the *walls* and outside the tunnel. Remember to avoid *over control*. Make small adjustments and wait for the ship to respond. To compete *against the clock* press the timer key to start and press it again when you finish.

3. *Floating Tunnel Obstacle Course:* This course is also designed to improve maneuvering skills but you also need to watch your altitude and pitch carefully. The course is in Area A-3 and starts in Sector F-7 at X=369, Z=1029, alt = 534. The course is a series of rectangles that you must fly through. Use the timer and compete against yourself or your friends.

4. *Aerial Target Range:* The aerial target range is to increase your proficiency in the use of weapons. There is a target range located in Area A-2, Sectors H-4 through H-10. Start at Sector H-3 X=7884, Z=5281, alt = 5175. The object is to fly through the range hitting as many targets as you can in the least amount of time. There are 14 triangle type figures staggered from Sectors H-4 to H-10. To start the clock, press the timer key and press it again when you are finished.

5. *Target Range:* The target range located in Area B-2 starts in Sector J-10 and goes through several connecting sectors. The object is to increase your weapon proficiency by flying through the sectors hitting as many targets as quickly as possible.

THE DATA LINK

Press the Data Link key to request up-link to ECHELON Headquarters. When the link comes on line you have 4 selections from the main menu.

1. Docking
2. Game Options
3. Pirate Maps
- X. Terminate

The following is a brief description of each selection.

1- DOCKING:

1. *Docking Procedures:* This gives instructions on how to re-dock once leaving the base station. Any time during flight you can return to the base station to re-energize your shields, get more fuel, ammunition or droids. Any damage that your craft has sustained will be automatically repaired when you dock. Upon entering the base, your maximum speed is automatically reduced to 1/4 of normal. Each time you dock, you will receive a new RPV (if needed) and your shield energy level will be replenished. To continue, press the 'Space Bar'.

2. *Weapons and Fuel*: This option allows you to select the amount of fuel and the amount of ammunition for each of your weapons. This can be done up to the maximum capacity (in weight) that can be held by your spacecraft. To activate a category use the LipStik or press the *Space Bar*. Use the (+) or (-) keys to add or subtract the amount of ammunition or fuel. To exit, press '/'.

3. *Default Weapons/Fuel*: This option automatically selects the normal loading of ammunition and fuel. You may then make adjustments if you wish. To exit press '/'.

NOTE: YOU MUST BE DOCKED TO ENGAGE OPTIONS 2 AND 3 OF THE DOCKING SELECTION.

2- GAME OPTIONS:

1. *Combat*: There are two choices you can make under this category.

- *Enemy Strength* - This allows you to vary the enemy strength between six different levels, including no enemies.

- *Structure Display* - This option allows you to either leave the structures or buildings on screen during combat or to not display them during combat. The advantage to turning the display off during combat is that the rate at which the screen updates will increase. This will speed up the action. However, some find turning the structure display off to be disorienting.

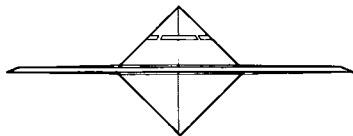

2. *Load/Save/Restart*: This option allows you to **SAVE** a game in progress, **LOAD** a previously saved game and resume play, **FORMAT** a disk, or **RESTART** a game without re-booting. Please follow the instructions outlined on the screen carefully. **In order to SAVE a game, you must have your own disk. You CANNOT save to the ECHELON game disk. If your disk has NOT been used before, you will have to FORMAT it.**

3. *Sound Adjustment* - You may adjust the sound filter settings of the game to provide the optimum sound for your computer. Please follow the instructions outlined on the screen.

3- *PIRATE MAPS:*

This allows you to view the pieces displayed on the Pirate Maps. The maps start with no information but gradually fill in each time objects are teleported. There are six different maps and each is used to help locate the Pirate Base. For more information on the maps, see the section on the six maps.

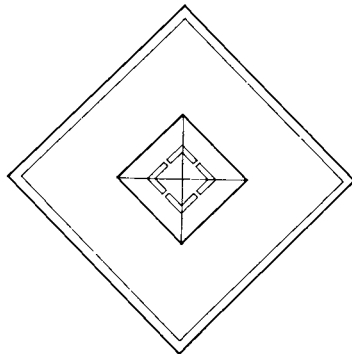

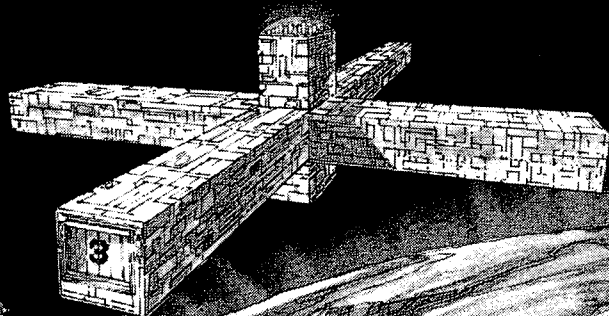

DOCKING

1. The main base is located in Area B-3, Sector G-7. Fly to this location at an altitude of 10,000 meters.
2. To get to the docking area you must fly in through one of the four entry bays.
3. Line your spacecraft (at alt 10,000 m) directly in front of one of the bay entry doors and slowly begin to approach the opening.

4. As your spacecraft begins to enter the bay, your speed will automatically be reduced.
5. Keep your spacecraft in the center of the entry bay. If you hit the sides of the entry bay, you'll hear a *thud*. You cannot fly through the walls of the space station.
6. Keep an eye on your X and Z coordinates. When your coordinates are approximately $X=5000$, $Z=5000$ at altitude 10,000 meters, you have reached the docking bay.
7. Rotate your spacecraft to a heading of 00 and the docking system will be automatically engaged.

NOTE: PITCH MUST ALSO BE ZERO.

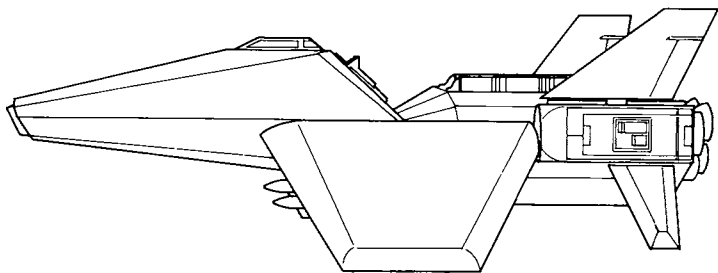

ISIS - THE 10TH PLANET

History of Isis

Scientists had long suspected the existence of a 10th Planet. In 1821, 40 years after the discovery of the seventh planet, Uranus, French Astronomer Alexis Bouvard noticed that Uranus' observed position did not agree with its calculated orbit. Uranus was being pulled slightly off course by the gravitational attraction of an outer planet. This led to search and discovery of Neptune, the eighth planet. But the mass of Neptune did not account for the distortion in Uranus' orbit so a search began for a ninth planet. When Pluto was discovered in 1930, it's mass was much too small to fully account for Uranus' wobble, so an earnest search for a tenth planet had been continuing at the U.S. Naval Observatory (USNO) since the early 1980's.

In 1996 a research team from USNO announced the discovery of Isis, the 10th Planet in our solar system. The planet's mass, approximately five times that of Earth's, was of sufficient size to effect the gravitational field of Uranus. Isis has a thin atmosphere made up primarily of Oxygen, Carbon Dioxide, Nitrogen and Argon. Its orbit is elliptical and it takes over 340 earth years to orbit the sun.

The biggest surprise however, was yet to come. In 2011, the first unmanned landing probe reached Isis. The photographs and data sent back finally verified that Earth was not the only Planet where life has existed. Signs of an ancient civilization were observed on the surface of the planet, but life was no longer present. Evidence indicated a great cataclysm had taken place and large areas of the planet showed evidence of incredible devastation.

Upon analysis of the information, general consensus among scientists was that since conditions were too harsh and too cold for life to have evolved on the planet at its current position in our solar system, Isis must have been part of another star system in the Universe. The star exploded or died and the planets were released from the stars gravitational pull and wandered to different parts of the Universe. Isis traveled through space until it was caught by the gravitational pull of our sun, thus becoming the 10th planet.

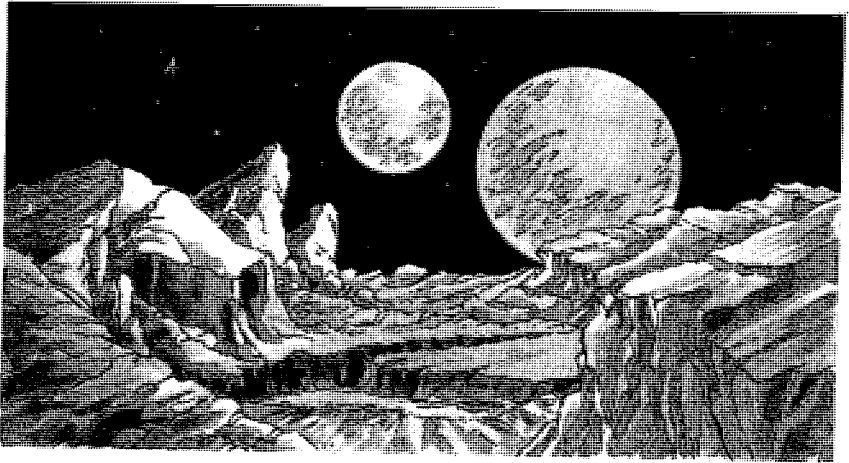

STATISTICS OF ISIS

Mean distance from Sun	6.5 billion km
Period of orbit	341 Earth years
Period of rotation	47 Earth Hours
Diameter	28,940 Km
Mass relative to the Earth	5.3
Surface gravity relative to Earth	1.25

HISTORICAL TIME LINE

1996 - Discovery of 10th Planet. Planet is named Isis.

2011 - First unmanned landing probe reaches Planet - Discovers Ancient Civilization once flourished on Isis when it was part of another Solar System.

2012 - United Nations organizes the International Space Federation (ISF).

2015 - First manned spacecraft sent to Isis.

2017 - Scientific team arrives on Planet.
Discovery of Dylidium, a new element.

2020 to 2030 -
Five more scientific expeditions are made to Isis.

2031 - Development of Laser Fusion Drive, cuts travel time to planet to 1.2 years.

2035 - First Martian Colonies developed and settled.

2037 - Miners arrive to collect Dylidium and other precious metals on Isis.

2041 - **Alphan War** Period Begins when an ISF spacecraft accidentally destroys an alien vessel - Skirmishes between Alphan spacecraft and ISF spacecraft continue.

2043 - The major battle of the Alphan War takes place over what is now Zone 106, Area A-2. Five ISF spacecraft destroyed; 3 Alphan spacecraft destroyed.

2045 - Contact finally made with Alphan officials and a non aggression pact is reached. However, isolated random attacks still occur.

2054 - McAdams Penitentiary established on Isis. Prisoners of this facility are used to mine Dylidium.

2056 to 2081 -
Exploration and mining continues - Many new colonies established between Earth and Isis.

2082 - Prison riots occur at McAdams Penitentiary, 350 prisoners escape. Over 200 prisoners and guards are killed. ISF closes the Penitentiary.

2083 - Pirates begin raiding ISF Facilities. Many pirates are believed to be escapees from the prison. Others are colonists who have grown disenchanted with ISF controls and regulations and want to set up their own system of commerce.

2093 - Raid on Isis outposts continue. Pirates begin to control and dominate the area. Pirates have developed sophisticated disruption equipment which allows them to block communication between ISF spacecraft and their bases. In addition, Pirate spacecraft are equipped with stealth capabilities and are undetectable on long range scanners. This allows them to strike quickly before being spotted on radar and disappear without being tracked. Pirate spacecraft are only visible on short range scanners. The Pirates are not strong enough for a full attack on the ISF, but their guerrilla tactics have become increasingly more effective.

2094 - Establishment of ECHELON headquarters on Isis. Patrol Zones are set up to cover selected areas of the planet. Eight of the more strategic Patrol Zones have stationary orbit Base Stations for refueling, maintenance, supplies and sleeping quarters. These Base Stations are fully automated and have a level 3 perimeter defense system. Only top military personnel are assigned to ECHELON. Its presence on Isis will hopefully help the ISF regain control of this area of space from the Pirates.

2095 - Major Thomas Allen attempts to infiltrate the pirate organization. He is not heard from again.

2096 - The completion of a new combat and exploration vehicle, C-104 Tomahawk. The C-104 spacecraft has the latest in advanced weaponry and scientific equipment. A limited number of new spacecraft being delivered to Echelon will be flown by only the best ISF Pilots.



YOUR MISSION: CLASSIFIED

BRIEFING: Space pirates have been a problem to the ISF since their appearance over a decade ago. Their past raids had mainly been restricted to isolated spacecraft and outposts. Then three years ago, major technological improvements in their equipment and weaponry occurred. Since then, their raids have become more daring. Equipped with electronic disruption equipment and stealth capabilities, they have caused an increasing amount of damage to ISF facilities.

The ISF established Echelon two years ago to regain firm control inside the area. Progress however, has been marginal. *Major Thomas Allen* was given the task of infiltrating the pirate organization over 16 months ago, but his status at this point is unknown. Pirates continue to use the element of surprise and have enjoyed an increasing amount of success against ISF facilities throughout the area.

OBJECTIVE: Your assignment is to locate the Space Pirate's Main Base of operation. According to Intelligence reports, it is somewhere inside your Patrol Zone. Your investigation requires you to retrieve artifacts and information throughout the zone to find the answer. Any pirate spacecraft spotted inside your assigned area should be neutralized. *Good Luck, Commander!*

THE PIRATE CODE

The Pirate Base is somewhere inside your Patrol Zone. Finding the base will take a great deal of 'detective work'.

Through intelligence reports, we know that the Space Pirates have developed a secret code to encrypt all messages and transmissions. Your teleporter's material analyzer is programmed to decipher as much of this code as possible. Many of the objects and artifacts that you teleport aboard will contain writings and inscriptions. Some of these are clues and many are written in Pirate Code. Breaking (deciphering) the code is essential to the solution of the game.

THE SIX STEPS

We also know that the Pirates have developed a sophisticated cloaking system which constantly keeps their base invisible and undetectable by our scanners. Latest reports indicate that there is a special sequence of 6 steps that can be performed to de-activate the cloaking devices. Apparently the designers set up this sequence to serve as an emergency override in the event of a major malfunction in the system. **THESE STEPS MUST BE PERFORMED IN THE PROPER SEQUENCE.** If any of the steps are executed out of order, the person must start again at STEP 1.

THE SIX MAPS

EACH OF THE SIX STEPS IS REPRESENTED BY A MAP. The maps are in your Data Link system. The maps have no information to begin with, but portions of a map will fill in each time an object is teleported aboard.

Each map has a graphic and a text section. Every time an object is teleported, a new piece of graphic and a new piece of text will be revealed. (If you cash in the object for credit.)

THE MAPS ARE IDENTIFIED BY COLOR. When an object is teleported, the computer will give its description, the number of credits available, and **THE COLOR OF ITS ASSOCIATED MAP.**

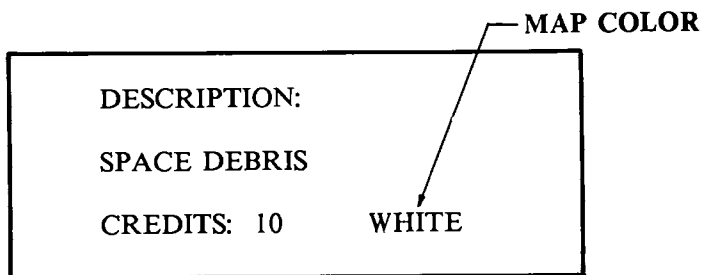

If you cash the object in for credit, the map will be shown and the graphic and text pieces will appear. (**NOTE: BE SURE TO SAVE THE GAME PERIODICALLY. THIS MUST BE DONE TO PRESERVE MAP PIECES BETWEEN PLAYING SESSIONS.**)

When all the objects in the Patrol Zone have been teleported, all 6 maps will be filled in. The text with each map gives instructions on how to complete one of the 6 steps. The text, however, is in Pirate Code and must be deciphered.

COMPLETING YOUR MISSION

To solve the mystery and complete your mission, do the following:

1. **FILL IN THE MAPS** by teleporting objects aboard your spacecraft.
2. **WRITE DOWN CLUES** in the **IMPORTANT CLUES SECTIONS** of this manual. Each map has its own **IMPORTANT CLUES** page for listing clues that were discovered with that particular map. Most important clues will be written in Pirate Code and will have to be decoded. For example, you may bring in an object that says ...

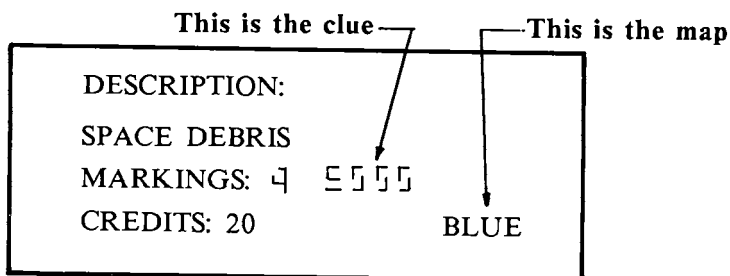

You should write the clue on the **IMPORTANT CLUES** list for the **BLUE** map.

Keeping the clues separated this way may provide an answer to the mystery before all map pieces are revealed.

3. **BREAK THE PIRATE CODE** and interpret the instructions for each of the 6 steps. Scattered throughout the Zone are clues to the meanings of the Pirate Code. These clues are on teleported objects as well as written on walls or buildings. Each time you decipher a letter or number, write it down on the **PIRATE CIPHERS** page at the back of this manual.

4. **DETERMINE THE CORRECT ORDER OF THE STEPS.** Once you finish all 6 maps and break the code, you will be able to read the instructions on how to complete each of the 6 steps. All

steps involve flying to a specific point and performing specific maneuvers with your spacecraft. If you successfully follow the instruction for that step, a sign will be given. Thus you will receive 6 signs for successfully completing 6 steps. There is a problem; however, **YOU MUST COMPLETE THE 6 STEPS IN A SPECIFIC ORDER TO DEACTIVATE THE CLOAKING SYSTEM AND WIN THE GAME.**

HINT: Look for clues of the form:

"Something **PRECEDES** something"

These are very important and should always be written down.

HINT: Each MAP graphic is important. It represents something within the zone and is related to a 'PRECEDES' clue.

5. **COMPLETE THE 6 STEPS IN THEIR PROPER ORDER.** As each step is completed, the sign for that step will be given, but there will be no indication given as to whether or not you are still on the correct sequence. You will have to wait until all 6 steps are complete to find out. If you find the proper order, you'll know it. If not, try again. **USE THE PRECEDES CLUES.** Without them you may have a rough time. There are 720 different combinations.

CROSS PRECEDES PYRAMID

PIRATE CIPHERS

𐄀 = _____	𐄁 = _____	𐄂 = C
𐄃 = ¹ B	𐄄 = ² O	𐄅 = _____
𐄆 = _____	𐄇 = _____	𐄈 = _____
𐄉 = _____	𐄊 = _____	𐄋 = _____
③ 𐄌 = _____	𐄍 = _____	𐄎 = _____
𐄏 = _____	𐄐 = _____	𐄑 = _____
𐄒 = _____	𐄓 = _____	𐄔 = ⁵ _____
𐄕 = _____	𐄖 = _____	𐄗 = _____
𐄘 = G	𐄙 = D	𐄚 = A
𐄛 = _____	𐄜 = ⁴ _____	𐄝 = _____
𐄞 = _____	𐄟 = _____	𐄠 = _____
𐄡 = _____	𐄢 = _____	𐄣 = _____

GENERAL INFORMATION ABOUT YOUR PATROL ZONE

Information presented here is not to be misinterpreted as covering all items within the area. These represent only a few highlights from each of the explored areas.

A-1: *Ancient bridge* spans a frozen river bed in Sector H-7. Elements of bridge date back 3,000 years.

A-2: Major battle of the Alphan War took place over this area. Several destroyed spacecraft of Alphan and ISF configuration can still be found on the surface throughout the area. The *Echelon target range* is located in Sectors H-4 through H-10. Only ISF personnel with Level 1 security clearance are authorized within these sectors.

A-3: The Echelon Training Simulator *Floating Tunnel* in Section F-7 through F-10. Only ISF personnel with Level 1 security clearance are authorized within these sectors.

A-4: Remains of an *ancient Isis city* can be found in Section C-9.

A-5: The research station located in Sector I-7 was set up by Dr. Adrian Van Kempe, his daughter Sonja and his research assistant. Van Kempe was generally considered to be top of his field in the Science of Astro Physics. In April 2092 he sent a message to his old University informing them that his experiment with Lithicite Crystal was a failure and that he was closing down his research facility to accept a position with a private corporation.

Van Kempe, his daughter and research assistant have not been heard from since. It is assumed their spacecraft was lost on its return back to Earth

A-6: Mining and drilling operations were set up in Sectors D-10, E-11 and H-12 after rich deposits of dyldidium were located in this area in 2082.

B-1: Probes sent to this area have been unable to verify a report that an ancient civilization lies somewhere in the area. Ships on patrol are requested to report this find if any evidence is found.

B-2: *Echelon Target Range* located in Sectors F-8, G-8, H-8, I-10, J-11. Only authorized ISF personnel with Level 1 security clearance are allowed within these sectors.

B-3: The *Echelon Obstacle Course* is located in B-12. Only ISF personnel with Level 1 clearance are authorized within this sector. A landing airstrip is in Sector J-10. Try your luck landing here.

B-4: The *Echelon Ground Obstacle Course* is located in Sectors F-4 through F-7. Only ISF personnel with Level 1 clearance are authorized within these sectors.

B-5: No information available. Area has several structures photographed by satellite, but large tracts of the area are unexplored.

B-6: *Gigantic Rock Figures* in Sector L-11 display detailed work of great craftsmanship. Many scientists have suggested that these figures had religious significance to the early inhabitants of the planet.

C-1: *Large Ancient Dam* is located on a frozen river bed in Sector F-10.

C-2: During an exploration of this area, an extraordinary and startling image was found. *A huge star figure*, covering an area of several sectors, was discovered. A concentrated study has been made of this figure and comparisons have been made between the star figure and similar figures found on Earth in South America. So far, the purpose and origins of this star have not yet been established.

C-3: Ancient bridge spans a frozen river in Sector M-9.

C-4: In Sector M-12 is an early refuel and supply area known as *The Crossroads*. The Crossroads was an early outpost used extensively in the early to mid 21st Century for scientific expeditions. More modern facilities at other sites were later constructed and the Crossroads was abandoned. The *Echelon Training Course* (touch and go) is located in Sectors H-6 thru H-10. Only ISF personnel with Level 1 security clearance are authorized within these sectors.

C-5: One of the most severe blows to the ISF occurred in Sector C-5. After 16 months travel from earth, *Largo*, the largest of the ISF superfreighters, was nearing Echelon. The Pirate raids had been taking their toll on Echelon reserve supplies and many items aboard the *Largo* were in short supply at the base. The freighter was under military escort and at last report, indicated at current speed, they would reach Echelon within the next week. That was the last message received from the *Largo*.

At Echelon Headquarters, the position of the superfreighter was being routinely scanned. Suddenly the large ship stopped and vanished from the monitor screen. Six LC-24s were scrambled to the last known heading. When they arrived, all that was found were the remains of several escort fighters but the freighter itself was gone. A thorough search was undertaken, but the huge freighter was never found. The loss of supplies nearly spelled disaster for the base. Supplies of food and medical equipment nearly ran out before an emergency shipment could be received from surrounding colonies. It is assumed that pirates attacked the *Largo*. By employing communication disrupters and stealth equipment, the distress message was blocked. The mystery of what happened to the freighter after the attack, however, remains to be solved.

C-6: Area C-6 was opened up in 2039 to independent mining operations. Isolated settlements can be found throughout the area. Most are abandoned now because of Pirate attacks in the area.

D-1: Independent Mining Facilities are located throughout this area.

D-2: No information available. Area has several large structures photographed by satellite. Large tracts remain unexplored.

D-3: Remains of *Ancient Isis City* can be found in Sector H-3. City has several large buildings that are still intact.

D-4: No information available. Area has many large structures which have been photographed by satellite but large tracts remain unexplored.

D-5: The *Refinery* located in B-7 was built in 2042 to process Dylidium and Titanium into a high strength alloy. The facility was

built to furnish replacement parts for spacecraft during the Alphan War.

D-6: The *McAdams Penitentiary* located in Sector I-10 was built in 2054 for prisoners who were considered too dangerous to be housed in other facilities. The inmates were required to work in the Dylidium mines. When Lithicite, a very unique crystal, was discovered at the mine, many prisoners were killed in a strange accident. Apparently the laser used to mine Dylidium can excite the crystal and under the right conditions cause an explosion. This led to the riots of 2082 where 350 inmates escaped in a prison freighter. Most of the prison itself was destroyed in the revolt and remaining inmates were transferred to other facilities. The prison was officially closed in March 2082.

E-1: The *Abandoned Landing Strip* in Sector C-7 was established in 2021 as the original ISF base of operations. The landing strip was attacked during the early phase of the Alphan War and personnel were evacuated to a more defensible position.

E-2: The *Research Radio Telescope* in Sector C-9 was built in 2037. Information and data at this site are analyzed by astronomers at Echelon.

E-5: No information available. Area has several large structures photographed by satellite but large tracts remain unexplored.

E-6: The *Mining Facility* located in Sectors C-7 was set up in 2039 when large deposits of the element Dylidium were discovered. Dylidium, when combined with Titanium, makes an extremely strong alloy and is used primarily in the construction of the outer hulls of spacecraft.

The mining operation began using prisoners from the McAdams Penitentiary in 2054. In 2079, Lithicite crystal was discovered at the site. This crystal is extremely dangerous and can explode if not handled correctly.

Efforts to mine the Lithicite crystal were unsuccessful and over 30 prisoners were killed in mining accidents. The mine was shut down in 2083 when more plentiful Dylidium deposits were discovered at

other locations. This location, though deserted, is considered dangerous and only military and mining officials with Level 3 security clearance may visit the site.

F-1: Remains of an *ancient Isis city* can be found in Sector F-6.

F-2: Sector L-6 features a large object that has been nicknamed the *Great Horn*. The 'Horn' was constructed by some alien civilization over 20 million years ago. The material is a metal that is not found anywhere in our solar system as far as we know. It is so hard that it is virtually indestructible.

F-3: The *Space Platform* in K-11 is owned by a private mining corporation. Remains of an ancient Isis town in Sector I-6 has been dated over 4,000 years old.

F-4: No information available. Area is unexplored.

F-5: Ancient remains of a small town is located in Sector E-7.

F-6: No information available. Area is unexplored.

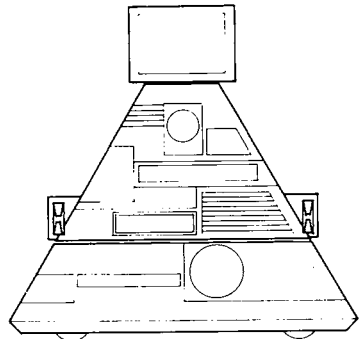
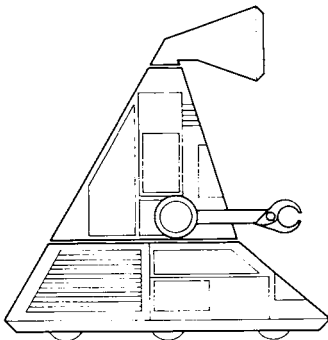

TROUBLE SHOOTING SECTION

The following is a list of common problems that may arise and suggestions for solving them. If you are having problems playing the game or controlling your aircraft, PLEASE RE-READ THIS MANUAL THOROUGHLY.

PROBLEM: The program fails to load or 'locks up' during play.

- SOLUTION:**
- A. Try removing the program disk, turning off the computer and disk drive and trying again.
 - B. Try using the Normal Load rather than the Fast Load option.
 - C. Try disconnecting printer interfaces, modems, cartridges or other peripheral equipment.
 - D. Run the CHECK programs as follows:
 - Step 1: Insert the Front side of the game disk
 - Step 2: Type: LOAD"FRONT CHECK",8 and hit <RETURN>
Then type: RUN <RETURN>
 - Step 3: Follow the instructions on the screen and the CHECK program will check every file on the front side of the disk.
 - Step 4: The program should display "DISK OKAY" at the end of the checking process. If it does not, refer to step 7 below.
 - Step 5: Now Type: LOAD"BACK CHECK",8 <RETURN>
Then type: RUN <RETURN>
 - Step 6: Follow the instructions and TURN THE DISK OVER. The program will now check the back side of the disk.
 - Step 7: If "DISK OKAY" was displayed after both front and back checks, then your computer is correctly reading the data from the disk. If "DISK OKAY" was not displayed 2 times, then your disk MAY BE DEFECTIVE.
 - E. If you are still unsuccessful call us at (801) 298-9077. If you have a Compuserve account, you may leave comments or questions for us at Compuserve I.D. #70127,766.

PROBLEM: Joystick doesn't work.

SOLUTION: Make sure the joystick is plugged into the front port (port #1) and the LipStik is plugged into the rear port (port #2).

PROBLEM: Weapons won't fire.

- CAUSES:**
- A. Weapons aren't armed.
 - B. C-104 control isn't selected.
 - C. C-104 front view isn't selected.

- PROBLEM:** Weapons fire continuously.
- CAUSE:**
- A. Blowing directly into the LipStik may deform the diaphragm. Turn the mouthpiece sideways and blow across it, not into it.
 - B. The LipStik may be damaged. See the REPLACEMENT PARTS Section.
- PROBLEM:** Hyperdrive won't engage.
- CAUSE:**
- A. ZONE MAP IS NOT ON SCREEN. (Zone Map key must be pressed first.)
- PROBLEM:** Objects won't teleport.
- CAUSE:**
- A. Velocities are not Zero.
 - B. Altitude (alt) is not 50 meters or less.
 - C. C-104 controls are not selected.
 - D. C-104 down view is not selected.
 - E. Flashing object is not in view on main screen.
- PROBLEM:** Docking system won't engage.
- CAUSE:**
- A. C-104 is not in Base Station.
 - B. C-104 controls not selected.
 - C. ALTITUDE (alt) not between 10,000 and 10,020 meters.
 - D. X and Z coordinates not close enough to 5000, 5000.
 - E. Heading or pitch not equal to Zero.
 - F. Velocity not equal to Zero.
- PROBLEM:** Keep hitting the ground.
- CAUSE:** Your pitch keeps getting off of Zero. This is normally caused by inadvertently pushing forward on the stick while turning. TRY USING THE AUTO-PITCH CENTERING FUNCTION. (Press <Return>)
- PROBLEM:** Can't keep nose of ship pitched up or down.
- CAUSE:** Auto Pitch Centering is on. Turn it off by pressing <Return>.
- PROBLEM:** Bank won't return to center.
- CAUSE:** Auto Bank Centering has been turned off. Turn it on by press 'A'.
- PROBLEM:** No enemies attack.
- CAUSE:**
- A. Fly to a more remote location. (Very few structures).
 - B. Enter the DATA LINK and select an enemy strength other than NO ENEMIES.
 - C. Terminate the DATA LINK.
 - D. Wait for enemy ships to attack (no more than 1 min.)

- PROBLEM:** Enemies won't stop attacking.
- SOLUTION:**
- A. Enter the DATA LINK and select Enemy Strength equal 1 (NO ENEMIES).
 - B. Terminate the DATA LINK.
 - C. The enemies currently attacking will be the last ones until you request more.
- PROBLEM:** Can't hit the enemy spacecraft.
- CAUSE:**
- A. Targets are out of range. Maximum range is 6300 meters for the MISSILES. That's a little over half way across a sector. The PHOTON CANNONS and HDAPPS have a range of 4600 meters and 1800 meters, respectively.
 - B. Enemy is evading your fire. Ships flying away are much harder to hit but are worth more points.
 - C. You're a poor shot.
- PROBLEM:** Main engines keep stopping.
- CAUSE:** You are holding the button down without moving the stick for more than 1/2 second.
Review the JOYSTICK CONTROLS SECTION.
- PROBLEM:** Can't deploy RPV.
- CAUSE:**
- A. Velocity is not Zero.
 - B. Altitude is not Zero.
 - C. RPV was destroyed.
(Return to Base and Dock)
- PROBLEM:** Can't retrieve RPV.
- CAUSE:**
- A. C-104 controls are not selected.
 - B. C-104 view is not selected.
 - C. Velocity is not zero.
 - D. RPV is not deployed.
 - E. RPV has been destroyed.
- PROBLEM:** Engines change speed but main screen doesn't change or move.
- CAUSE:**
- A. C-104 control is selected, but RPV view is selected.
 - B. RPV control is selected, but C-104 view is selected.
- PROBLEM:** RPV tracking can't keep C-104 on screen.
- CAUSE:** Main screen is zoomed in too far.

- PROBLEM:** RPV won't track C-104.
- CAUSE:**
- A. Tracking is not engaged.
 - B. RPV control is selected. (Tracking requires that the C-104 have control.)
- PROBLEM:** Main screen movement is very jerky. Weapons seem to curve strangely.
- CAUSE:** Main screen is zoomed in.
- PROBLEM:** Zone map doesn't keep track of your progress and Pirate Maps do not reflect pieces you've found from one playing session to another.
- CAUSE:**
- A. You are not saving your game before you turn off your computer or die (game over).
 - B. You are not reloading your saved game as you begin play. See the DATA LINK SECTION of this manual.
- PROBLEM:** Can't figure out how to continue when a Pirate Map is displayed.
- SOLUTION:** Press SPACEBAR or "/".
- PROBLEM:** Can't get out of the weapons and fuel loading sequence while docked.
- SOLUTION:** Press "/".
- PROBLEM:** Can't save or load a game.
- CAUSE:**
- A. Trying to save to the game disk. This disk is write protected. You must use your own PLAYER DISK.
 - B. Player disk is not FORMATTED. See DATA LINK SECTION under LOAD/SAVE/RESTART.
- PROBLEM:** Enemies won't appear even though they have been setup in the DATA LINK.
- CAUSE:** You are in an area with a lot of structures or objects. Pirates attack more often in more remote sectors.

REPLACEMENT PARTS

During the first 90 days that you own ECHELON, we will repair or replace a bad disk, headset, or other component that has a defect in the materials or workmanship. (Meaning that it was our fault.) Simply call us at (801) 298-9077 and explain the problem. We'll have you return the defective merchandise to us and we will repair or replace it and ship it back to you.

If you lose or damage any of the components or if the 90 day warranty has expired, you can obtain replacement parts for nominal charges as follows:

<u>Replacement Part</u>	<u>Cost</u>	<u>Shipping Charges</u>
Operations Manual	7.50	\$0.50
Keyboard Overlay	3.00	\$0.25
Patrol Zone Map	3.00	\$0.25
LipStik	10.00	\$1.00
<u>Accessory Items</u>	<u>Cost</u>	<u>Shipping Charges</u>
Complete Patrol Zone Map (all areas detailed)	5.00	\$0.50
Echelon Tee Shirt	11.00	\$1.00

To use your VISA or MASTERCARD or to order C.O.D. call our TOLL FREE ORDER LINE at 1-800-824-2549. To order by mail, send check or money order to: Access Software, Inc., 2561 South 1560 West, Woods Cross, Utah 84087.



(Specify size: S M L XL)

LIMITED WARRANTY

Access Software, Inc. warrants for a period of ninety (90) days from the date of purchase that, under normal use, the magnetic media upon which this program is recorded and accompanying hardware will not be defective; that, under normal use and without unauthorized modification, the program substantially conforms to the accompanying specifications and any Access authorized advertising material; and that the user documentation is substantially complete and contains the information Access deems necessary to use the program. If, during the ninety (90) day period a demonstrable defect in the program, documentation or accompanying hardware should appear, you may return the product to Access for repair or replacement at Access' option. Following the initial ninety day warranty period, defective media or hardware will be replaced for a replacement fee which is determined by what is defective. Defective product should be returned to: Access Software, Inc., 2561 South 1560 West, Woods Cross, Utah 84087, (801) 298-9077.

WHAT IS NOT COVERED BY THIS WARRANTY

THIS WARRANTY DOES NOT APPLY TO THE SOFTWARE PROGRAMS THEMSELVES. THE PROGRAMS ARE PROVIDED "AS IS".

THIS WARRANTY IS IN LIEU OF ALL OTHER WARRANTIES, WHETHER ORAL OR WRITTEN, EXPRESS OR IMPLIED, ANY IMPLIED WARRANTIES, INCLUDING IMPLIED WARRANTIES OF MERCHANTABILITY AND FITNESS FOR A PARTICULAR PURPOSE, ARE LIMITED IN DURATION TO NINETY DAYS FROM THE DATE OF PURCHASE. ACCESS SHALL NOT BE LIABLE FOR INCIDENTAL OR CONSEQUENTIAL DAMAGES FOR BREACH OF AN EXPRESS OR IMPLIED WARRANTY.

Some states do not allow the exclusion or limitation of incidental or consequential damages or limitations on how long an implied warranty lasts, so the above limitation or exclusion may not apply to you. This warranty gives you specific legal rights, and you may also have other rights which vary from state to state. Address all correspondence to Access Software, Inc., 2561 South 1560 West, Woods Cross, Utah 84087. Or call us at (801) 298-9077.

