

1st PRINTING DEC 99

SEGA



NAOMI KIT MANUAL
(JAMMA COMPATIBLE)

OWNER'S MANUAL

SEGA ENTERPRISES, INC. USA

MANUAL NO. 999-0890

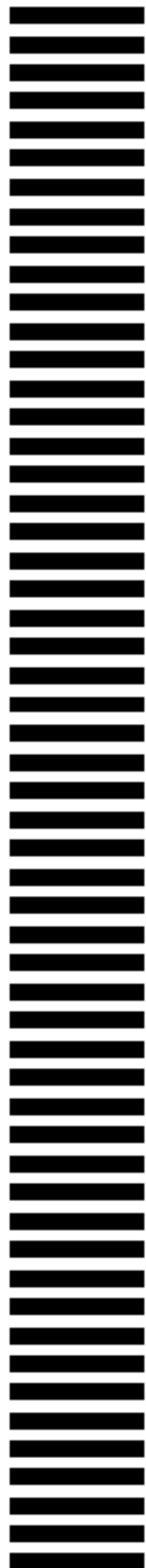

Warranty

Your new Sega Product is covered for a period of 90 days from the date of shipment. This certifies that the Printed Circuit Boards, Power Supplies and Monitor are to be free of defects in workmanship or materials under normal operating conditions. This also certifies that all Interactive Control Assemblies are to be free from defects in workmanship and materials under normal operating conditions. No other product in this machine is hereby covered.

Sellers sole liability in the event a warranted part described above fails shall be, at its option, to replace or repair the defective part during the warranty period. For Warranty claims, contact your Sega Distributor.

Should the Seller determine, by inspection that the product was caused by Accident, Misuse, Neglect, Alteration, Improper Repair, Installation or Testing, the warranty offered will be null and void.

Under no circumstances is the Seller responsible for any loss of profits, loss of use, or other damages.

This shall be the exclusive written Warranty of the original purchaser expressed in lieu of all other warranties expressed or implied. Under no circumstance shall it extend beyond the period of time listed above.

1. CONTENTS OF GAME

The following explanations apply to the case the product is functioning satisfactorily. Should there be any moves different from the following contents, some sort of faults may have occurred. Immediately look into the cause of the fault and eliminate the cause thereof to ensure satisfactory operation.

OUTLINE OF GAME

FROM AMONG THE 29 NBA TEAMS, SELECT YOUR FAVORITE TEAM

When a single play mode is selected, you battle against the computer controlled players in a tournament imagined real NBA playoffs.

If the score you have earned is greater than that of the opposing team at the game end, you can proceed to the next stage. In case of a tie score or less the game is over.

A player can buy into play a versus game, and the game can be continued up to the 4th quarter. Upon finishing a quarter, the player who has earned greater score can proceed to the next game. The player who lost the game can also play the game by executing a continue.

In case that a quarter ends in a tie, the player who has earned greater score in that quarter can proceed to the next quarter.

HOW TO OPERATE

Operate the lever and the 2 buttons to play the game.

LEVER:	movement
BLUE BUTTON:	(offense) pass (defense) steal
RED BUTTON:	(offense) shoot (defense) block shot/rebound

HOW TO PLAY

OFFENSE:

JUMP SHOT

When standing still, keep pressing down the shoot button to jump. Release the shoot button to shoot the ball.

RUNNING JUMPER

Press the shoot button to do a running jumper while dribbling.

If the defense stops your dribble, you will shoot a regular jump shot. You can perform a dunk shot depending on the distance to the goal or the timing of a shot.

PASS:

You can pass to any of your teammates by inclining the Lever in the direction of the intended player, and then pressing the pass button.

DEFENSE:

BLOCK SHOT

You can interrupt an opposing player's shot if you press the block button timely in accordance to his jump. You can decrease the probability of making the shot, even if you can not block the shot.

STEAL

When you are very close to the opposing player dribbling, if you press the steal button timely, you can steal the ball. You can also steal the ball if you timely press the steal button at a certain position when an opposing player is passing the ball.

1 - 1 TEST MODE

System Menu. This test mode mainly allows the IC board to be checked for accurate functioning, monitor color to be adjusted as well as COIN ASSIGNMENTS and GAME ASSIGNMENTS to be adjusted.

- 1.) After turning power on, press the TEST button to have the following test item menu displayed.
- 2.) Press the SERVICE button to move the arrow. Bring the arrow to the desired item and press the TEST button.

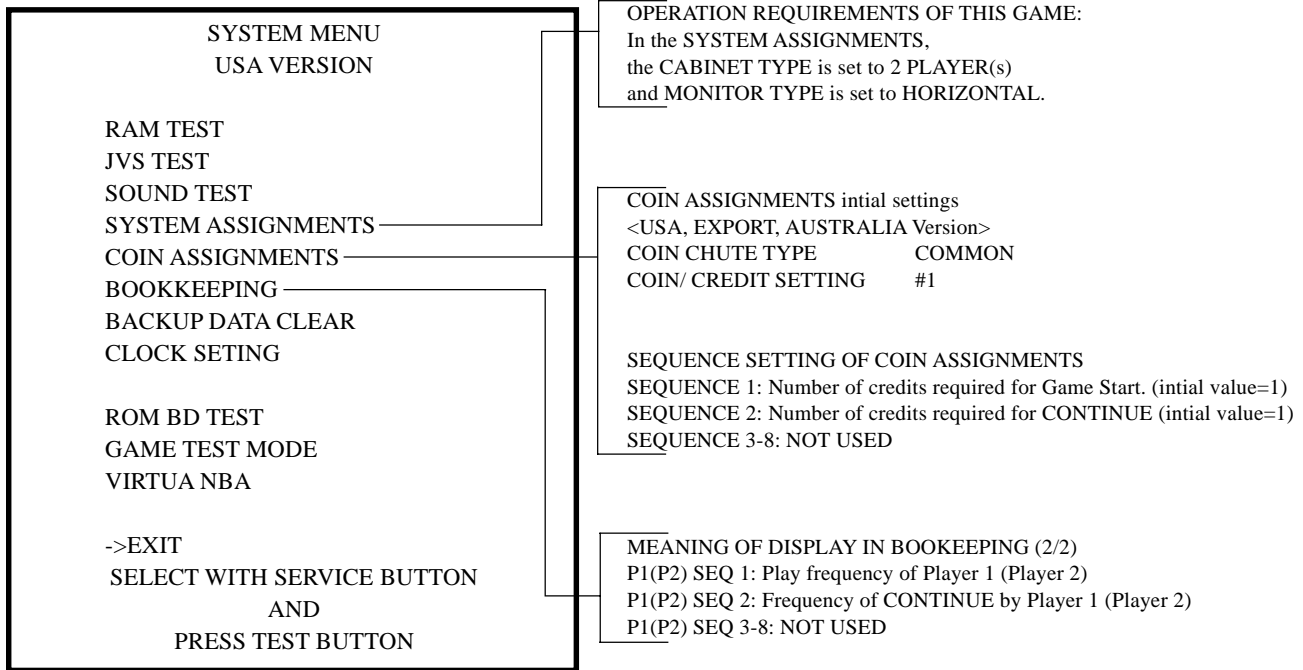

- 3.) Bring the arrow to the item of Game TEST MODE and press the TEST button to display the GAME TEST MENU peculiar to Virtua Tennis. See the next page onward.
- 4.) Upon finishing the test, bring the arrow to EXIT and press the TEST button to return to the Gam Mode.

1 - 2 TEST MENU



CAUTION!

The contents of settings changes in SYSTEM ASSIGNMENTS, COIN ASSIGNMENTS, and GAME TEST MODE are stored when the test mode is EXITed. If the power is turned off before EXITing, the contents of setting changes are ineffective. Be very careful of this point.

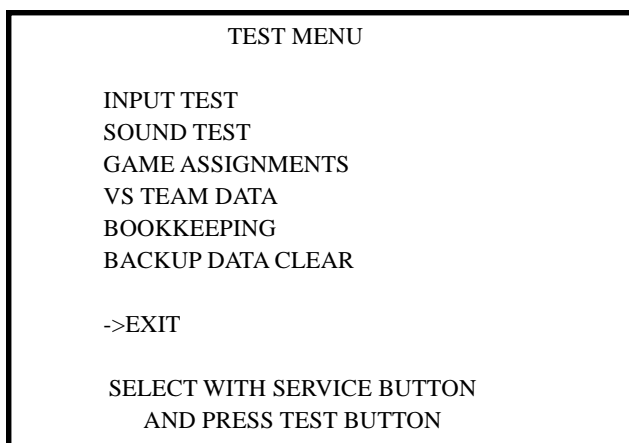

Bring the arrow to the item of GAME TEST MODE in the SYSTEM TEST MENU, and press the Test button to display the TEST MENU peculiar to Virtua Tennis.

Press the SERVICE button to move the arrow. Bring the arrow the desired item and press the TEST button.
Upon finishing the test, bring the arrow to EXIT and press the TEST button to return to the SYSTEM MENU MODE.

1 - 3 INPUT TEST

This test displays the state of each switch.

If this switch goes ON when activated, it is satisfactory.

Display varies depending on the JOYSTICK TYPE setting in (3) GAME ASSIGNMENTS.

INPUT TEST		
PLAYER	1P	2P
UP	OFF	OFF
DOWN	OFF	OFF
RIGHT	OFF	OFF
LEFT	OFF	OFF
SHOT1	OFF	OFF
SHOT2	OFF	OFF
START	OFF	OFF
COIN CHUTE #1	OFF	
COIN CHUTE #2	OFF	
SERVICE	OFF	
TEST	OFF	

PRESS TEST BUTTON TO EXIT

If any switches do not report ON when switch is activated, return to the menu screen and take steps described in “VOLUME SETTING”. Then return to this test and confirm the switches perform adequately.

To return to the menu screen, press the TEST Button while holding the SERVICE Button down.

1 - 4 SOUND TEST

This allows sound and background used in the game to be checked/ tested.

SOUND TEST	
AUTO	
SE	
BGM AND VOICE	
SE PACIFIC	
SE MIDWEST	
SE CENTRAL	
SE ATLANTIC	
BGM	1 3 4 5 6
BGM	7 8 9 10 11 12

SELECT WITH SERVICE BUTTON
PRESS TEST BUTTON TO EXIT

To check them, specify the appropriate item using the SERVICE Button and press the TEST Button to generate the sound.

By default, the arrow is located at EXIT.

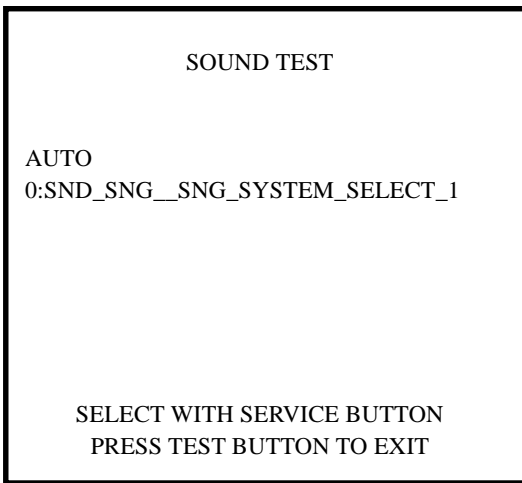

In this test, the sound displayed under AUTO in the following menu screen is played for 3 seconds in order. After performing all the BGM and sound effects, the screen automatically returns to the SOUND TEST menu. To return to the SOUND TEST menu even in the middle of test, press the TEST button with the SERVICE button pressed down.

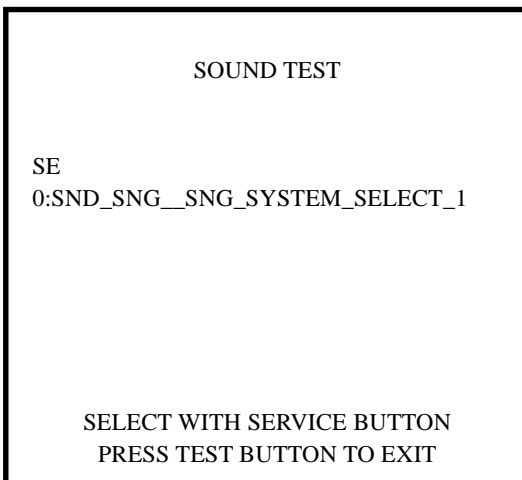

This allows sound effects and voices used in the game to be tested. Pressing the SERVICE button increases the SOUND No. and causes the sound to be played. Both 1P and 2P sides of the control panel can be used for this test. Incline the lever to change the SOUND No. and Press the TEST button to have the sound played. Press the TEST Button to return to the SOUND TEST Menu.

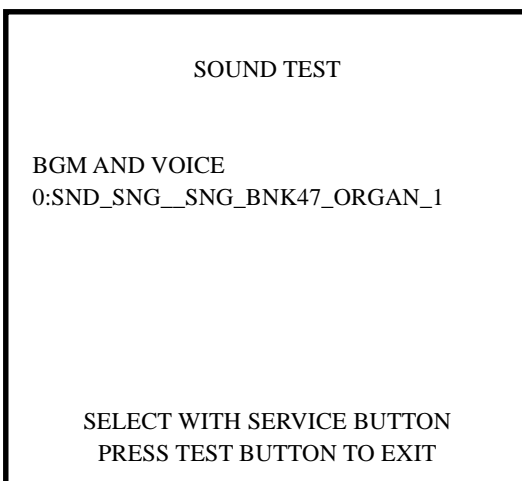

This allows the BGM and voices used during the game to be checked. Pressing the SERVICE button increases the SOUND No. and causes the sound to be played. Both the 1P and the 2P sides of the control panel can be used for this test. Incline the lever to change the SOUND No. and press the button to have the sound played.

SOUND TEST

SE PACIFIC
0:SND_SEB_GOLDEN STATE_SELECT_GSW

SELECT WITH SERVICE BUTTON
PRESS TEST BUTTON TO EXIT

This allows the BGM and voices used during the game to be checked. Pressing the SERVICE button increases the SOUND No. and causes the sound to be played. Both the 1P and the 2P sides of the control panel can be used for this test. Incline the lever to change the SOUND No. and press the button to have the sound played.

SOUND TEST

SE MIDWEST
0:SND_SEB_DALLAS_SELECT_DAL

SELECT WITH SERVICE BUTTON
PRESS TEST BUTTON TO EXIT

This allows the BGM and voices used during the game to be checked. Pressing the SERVICE button increases the SOUND No. and causes the sound to be played. Both the 1P and the 2P sides of the control panel can be used for this test. Incline the lever to change the SOUND No. and press the button to have the sound played.

SOUND TEST

SE CENTRAL
0:SND_SEB_ATLANTA_SELECT_ATL

SELECT WITH SERVICE BUTTON
PRESS TEST BUTTON TO EXIT

This allows the BGM and voices used during the game to be checked. Pressing the SERVICE button increases the SOUND No. and causes the sound to be played. Both the 1P and the 2P sides of the control panel can be used for this test. Incline the lever to change the SOUND No. and press the button to have the sound played.

SOUND TEST

SE ATLANTIC
0:SND_SEB_BOSTON_SELECT_BOS

SELECT WITH SERVICE BUTTON
PRESS TEST BUTTON TO EXIT

This allows the BGM and voices used during the game to be checked. Pressing the SERVICE button increases the SOUND No. and causes the sound to be played. Both the 1P and the 2P sides of the control panel can be used for this test. Incline the lever to change the SOUND No. and press the button to have the sound played.

SOUND TEST

SE 1 3 4 5 6
0:SND_SNG_SNG_BNK11_BGM_1

SELECT WITH SERVICE BUTTON
PRESS TEST BUTTON TO EXIT

This allows the BGM and voices used during the game to be checked. Pressing the SERVICE button increases the SOUND No. and causes the sound to be played. Both the 1P and the 2P sides of the control panel can be used for this test. Incline the lever to change the SOUND No. and press the button to have the sound played.

SOUND TEST

SE 7 8 9 10 11 12
0:SND_SNG_SNG_BNK42_BGM_7

SELECT WITH SERVICE BUTTON
PRESS TEST BUTTON TO EXIT

This allows the BGM and voices used during the game to be checked. Pressing the SERVICE button increases the SOUND No. and causes the sound to be played. Both the 1P and the 2P sides of the control panel can be used for this test. Incline the lever to change the SOUND No. and press the button to have the sound played.

1 - 5 GAME ASSIGNMENTS

GAME ASSIGNMENTS	
COUNTRY	*****
CONTINUE TYPE	WINNER NO CHARGE
DIFFICULTY	NORMAL
ONE MATCH MODE	OFF
TIME SET 1P	2.00
TIME SET 2P	2.00
>EXIT	

SELECT WITH SERVICE BUTTON
AND PRESS TEST BUTTON TO EXIT

In this test, game difficulty adjustments, time setting, etc. can be changed. Move the arrow to the desired item by SERVICE button and press the TEST button to change the setting. Select EXIT to return to the Menu Screen.

- **TIME SET**
The time for one play can be set within a range of 1'15" and 3'00". The standard setting is 2'00".
- **ONE MATCH MODE**
Select from among OFF, 1 GAME, and FULL GAME.
OFF- This is the standard setting
1 GAME- Game is over when one game is finished. This option is for some sorts of event such as game competition, etc.
FULL GAME- Regardless of communication mode 1P (against the computer) mode, the game starts at the 1st quarter.
- **GAME DIFFICULTY**
Sets the difficulty level in 4 categories, i.e., EASY, NORMAL, HARD, and HARDEST.
- **CONTINUE TYPE**
Game continue setting. "CHARGE" and "WINNER NO CHARGE" settings are available. The standard setting is WINNER NO CHARGE.
WINNER NO CHARGE>The player who wins the versus game can continue to play.
CHARGE>In this option, each time game is finished, the player who plays the game against the computer is urged to continue whether he wins or not. In versus game, the players are urged to continue each time quarter ends regardless of win or loss.
VS. WIN TO CHARGE>In this option, when played against a computer, the player is urged to continue each time when game is finished. When played in VS. mode, the player who wins the game can continue the game.

1 - 5 VS. TEAM DATA

In this test, the team data oin the vs. mode can be checked.

USE:

Displays team selection frequency.

WIN:

Displays each team's total number of victories in versus games.

DRAW:

Displays each team's total number of draws in versus games.

LOSE:

Displays each team's total number of losses in versus games.

VS TEAM DATA (1)				
TEAM NAME	USE	WIN	DRAW	LOSE
1 CELTICS	0	0	0	0
2 HEAT	0	0	0	0
3 NETS	0	0	0	0
4 KNICKS	0	0	0	0
5 MAGIC	0	0	0	0
6 76ERS	0	0	0	0
7 WIZARDS	0	0	0	0
8 HAWKS	0	0	0	0
9 HORNETS	0	0	0	0
10 BULLS	0	0	0	0
11 CAVALIERS	0	0	0	0
12 PISTONS	0	0	0	0
13 PACERS	0	0	0	0
14 BUCKS	0	0	0	0
15 RAPTORS	0	0	0	0

PRESS TEST BUTTON TO CONTINUE

VS TEAM DATA (2)				
TEAM NAME	USE	WIN	DRAW	LOSE
16 MAVERICKS	0	0	0	0
17 NUGGETS	0	0	0	0
18 ROCKETS	0	0	0	0
19 TIMBERWOLVES	0	0	0	0
20 SPURS	0	0	0	0
21 JAZZ	0	0	0	0
22 GRIZZLIES	0	0	0	0
23 WARRIORS	0	0	0	0
24 CLIPPERS	0	0	0	0
25 LAKERS	0	0	0	0
26 SUNS	0	0	0	0
27 TRAILBLAZERS	0	0	0	0
28 KINGS	0	0	0	0
29 SUPERSONICS	0	0	0	0
30 ALL NBA	0	0	0	0

PRESS TEST BUTTON TO EXIT

1 - 6 BOOKKEEPING

This test mode allows each of the CREDIT/TIME/GAME data to be ascertained.

BOOKKEEPING		PAGE1/5
COIN CHUTE #1		XXXXXXXXXXXX
COIN CHUTE #2		XXXXXXXXXXXX
TOTAL COINS		XXXXXXXXXXXX
COIN CREDITS		XXXXXXXXXXXX
SERVICE CREDITS		XXXXXXXXXXXX
TOTAL CREDITS		XXXXXXXXXXXX
NUMBER OF GAMES		XXXXXXXXXXXX
TOTAL	TIME	XDXXHXXMXXS
1P PLAY	TIME	XDXXHXXMXXS
VS. PLAY	TIME	XDXXHXXMXXS
AVERAGE PLAY	TIME	XXMXXS
LONGEST PLAY	TIME	XXMXXS
SHORTEST PLAY	TIME	XXMXXS
PLAY TIME RATE		XXX
VS. PLAY RATE		XXX

PRESS TEST BUTTON TO CONTINUE

NUMBER OF GAMES:

Displays the total number of games played

PLAYTIME:

Displays the game's play time

AVERAGE PLAY TIME:

Displays the average game play time.

LONGEST PLAY TIME:

Displays the longest game play time.

SHORTEST PLAY TIME:

Displays the shortest game play time.

TOTAL TIME:

Displays the total energized time.

1P PLAY TIME:

Displays the game time by 1P.

VS PLAY TIME:

Displays the total vs game play time.

PLAY TIME RATE:

Displays the rate of play time against the total energized time.

VS. PLAY RATE:

Displays the rate of versus play time against the total play time.

BOOKKEEPING PAGE 2/5			
TIME HISTOGRAM			
COURSE	BEGINNER	ADVANCED	EXPERT
~2M29S	0	0	0
2M30S~2M44S	0	0	0
2M45S~2M59S	0	0	0
3M00S~3M14S	0	0	0
3M15S~3M29S	0	0	0
3M30S~3M44S	0	0	0
3M45S~3M59S	0	0	0
4M00S~4M14S	0	0	0
4M15S~4M29S	0	0	0
4M30S~	0	0	0

PRESS TEST BUTTON TO CONTINUE

TIME HISTOGRAM:

Displays the histogram of play time.

BOOKKEEPING 3/5

TOTAL GAME COUNT	XXX
CONTINUE GAME COUNT	XXX
PLAYER 1 GAME COUNT	XXX
PLAYER 2 GAME COUNT	XXX

PRESS TEST BUTTON TO CONTINUE

TOTAL GAME COUNT:
Displays the number of games played.

CONTINUE GAME COUNT:
Displays the number of continued games played.

VS. CONTINUE GAME COUNT:
Displays the number of games continued versus games played.

PLAYER 1 GAME COUNT:
Displays the total number of games played at Player 1 side.

PLAYER 2 GAME COUNT:
Displays the total number of games played by Player 2 side.

BOOKKEEPING PAGE 4/5

DRAW COUNT	0
VS. WINS MAXIMUM	0

VS. WINS HISTOGRAM	
WINS	COUNT
1	0
2	0
3	0
4	0
5	0
6	0
7	0
8	0
9	0
10-14	0
15-19	0
20-24	0
25-29	0
30-39	0
40-49	0
50-	0

PRESS TEST BUTTON TO CONTINUE

DRAW COUNT:
Displays the number of draw games.

VS WINS MAXIMUM:
Displays the maximum number of successive wins in the versus mode.

VS WINS HISTOGRAM:
Displays the histogram of the total number of wins in the versus mode.

BOOKKEEPING 5/5

{TOURNAMENT REPORT}

1ST MATCH	0
CONFERENCE SEMI FINAL	0
CONFERENCE FINAL	0
FINAL MATCH	0
FINAL WINNER	0
ALL-NBA MATCH WINNER	0

>EXIT

SELECT WITH SERVICE BUTTON
PRESS TEST BUTTON TO EXIT

TOURNAMENT REPORT:
Displays how far players go without continue in the 1P mode.

1 - 7 BACK UP DATA CLEAR

Clears the contents of BOOKKEEPING.

BACK UP DATA CLEAR

YES (CLEAR)
->NO (CANCEL)

SELECT WITH SERVICE BUTTON AND
PRESS TEST BUTTON TO EXIT

When clearing bring-> to YES and when not clearing, to NO, by using the SERVICE SW and then push the TEST button.

When clearing has been finished, COMPLETED will be displayed.
Pressing the TEST button will have the MENU return to the screen.

2. GAME BOARD



IMPORTANT:

Ensure that the DIP SW setting is performed as designated. Failure to observe this may cause functioning not suitable for the operation, or malfunctioning.

2 -1 COMPOSITION OF GAME BOARD

ASSY SHIELD CASE NAO USA (840-0021D-01) : Virtua NBA

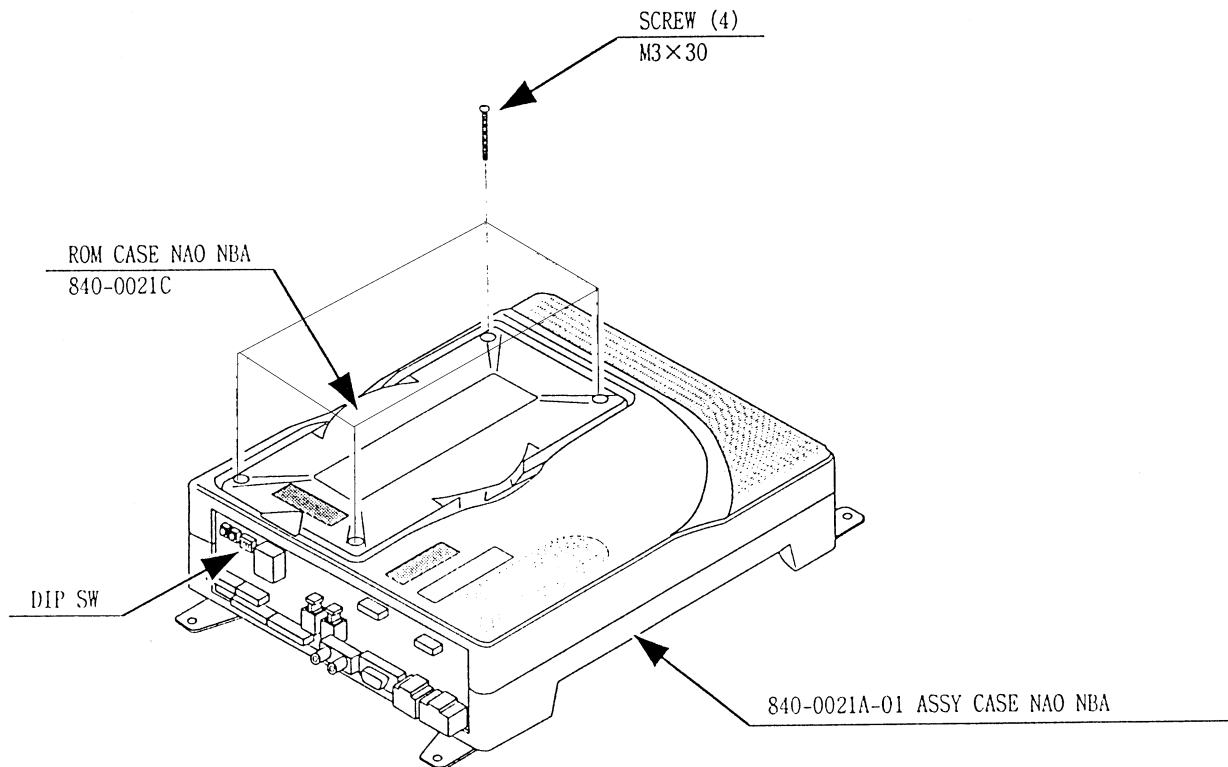

DIP SW SETTINGS

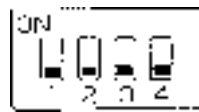

3. DESIGN RELATED PARTS/PARTS LIST

STICKERS AND GRAPHICS

ITEM NO.	PART NO.	DESCRIPTION
1	999-0892	INSTRUCTION SHEET#1 Virtua NBA
2	999-0896	MARQUEE Virtua NBA
3	999-0894	CONTROL PANEL OVERLAY Virtua NBA
4	999-0895	DECAL SIDE ART Virtua NBA (QTY.2)
5	999-0893	INSTRUCTION SHEET#2 Virtua NBA

JOYSTICKS AND BUTTONS

ITEM NO.	PART NO.	DESCRIPTION
1	50-7608-16	*ASSY JOY 4C BLACK
2	58-9133-L	*PUSH BUTTON GREEN
3	58-9122-L	*PUSH BUTTON BLUE
4	58-9111-L	*PUSH BUTTON WHT
5	95-0733-01	*MICRO SWITCH SILVER CONTACT

*These Joystick/buttons are HAPP components.

KIT INSTALLATION INSTRUCTIONS

- 1.) Install VGA Output to Jamma Interface.
- 2.) Install USB connector to Naomi Filter Board Port.
- 3.) You can use one of the extra grounds (shown in the picture on the following page) to go out to switched inputs. (The 5V and 12V can be used for whatever you like-coin meter, etc.)

MONITOR INFORMATION

You can use a
Standard Resolution-15,750K x 60 (#1 ON & #2-4 OFF)
or
High Resolution-31,000K x 10 (#1-4 OFF)

DIP SWITCH SELECTABLE
(Switch #1 on NAOMI FILTER BOARD)

4. WIRING

XFMR 120V 17v2Ax2
560-5407

POWER AMP 2 CH
838-13616

I/O Board
838-13683

GAME BD Virtua NBA
840-0021D-01

SW REGU FOR JVS
400-5397



CONTENTS OF WIRING BAG SEEN ABOVE

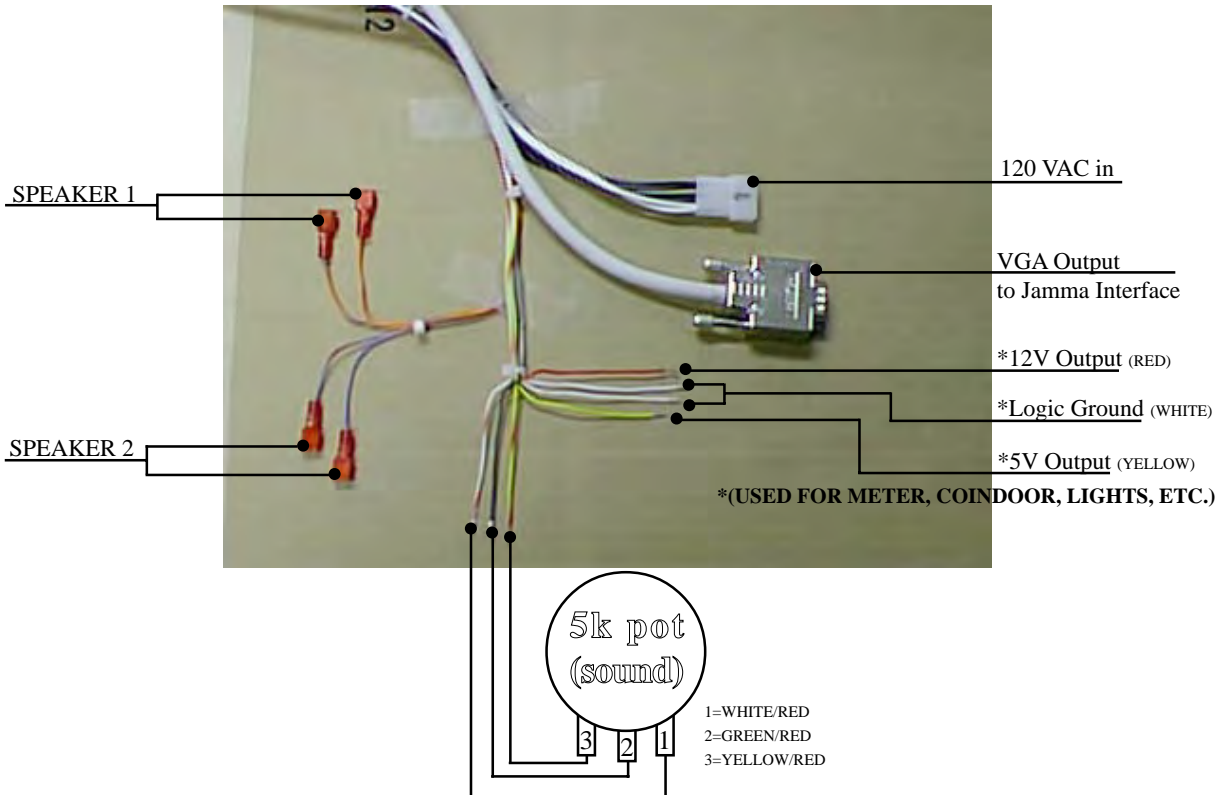

VISIT OUR ARCADE WEBSITE!

Netscape: SEGA ARCADE.COM

Location: <http://www.segaarcade.com/>

Mind 'i' SUNFUR - Offici Han's EarthLink My Yahoo! news

SEGA™

NAOMI™

SEGA ARCADE.COM

SEGA ARCADE

- CURRENT TITLES
- TIPS AND TRICKS
- COMMENT CORNER
- DISTRIBUTORS
- CORPORATE INFORMATION
- FROM THE DESK OF THE PRESIDENT



(image taken from CRAZY TAXI)

SEGA SITES

- ▶ SEGA of America
- ▶ SEGA of Japan
- ▶ SEGA Service Department
- ▶ SEGA GameWorks L.L.C.
- ▶ SEGA Tournament Network

[\[SEGA SOA\]](#) [\[SEGA STORE\]](#) [\[SEGA SERVICE\]](#) [\[SEGA JAPAN\]](#) [\[GAMWORKS\]](#) [\[HOME\]](#) [\[Current titles\]](#) [\[Merchandise\]](#)
[\[Distributors\]](#) [\[Tips & tricks\]](#) [\[Corporate info\]](#) [\[Comment Corner\]](#) [\[From the desk of the President\]](#)

All rights reserved SEGA Enterprises Inc. USA

VISIT OUR ARCADE SERVICE SITE FOR THE LATEST SERVICE TIPS AND UPDATES!

Netscape: SEU SERVICE HOMEPAGE

Location: <http://www.seuservice.com/> What's Related

Mind 'i' SUNFUR - Offici Han's EarthLink My Yahoo! news

SEGA SERVICE

[[What's new](#)][[Manuals](#)][[Bulletins](#)][[Part Numbers](#)][[Game Monitors](#)]
[[Board Systems](#)][[Mailing List](#)][[SEGA Distributors](#)][[Service Staff](#)][[Darl's Office](#)]



WHAT'S NEW
MANUALS
BULLETINS
PART NUMBERS
GAME MONITORS
BOARD SYSTEMS
MAILING LIST
SEGA DISTRIBUTORS
SERVICE STAFF
DARL'S OFFICE
HOME

[[Y2K COMPLIANCE](#)]

Sega Enterprises Inc., USA
Service Department
Phone (415) 701-6580
Fax (415) 701-6594

12/3/99
7:56 A.M.
Best Viewed with 

Coin-Op Links:
[Star Tech Journal](#)
[Amusement Industry Mega Site](#)

If you have any questions about this Home Page please E-Mail to:
darl.davidson@seu.sega.com
OR
han.rockdill@seu.sega.com

A total of **22153** people have accessed this page.

Get Acrobat Reader  Powered By FileMaker PRO 

THIS WEB SITE POWERED BY **WebSTAR 3**  



SEGA ENTERPRISES, INC. (USA)

45133 Industrial Drive
Fremont, CA 94538
(415) 701-6580 phone
(415) 701 6594 fax