

US & THEM

HOLLYWOOD



MYLSTAR

INSTRUCTION MANUAL

US VS. THEM (GAME GV-126) INSTRUCTION MANUAL

TABLE OF CONTENTS

SEC.	PAGE
I. INSTALLATION	1
II. INITIALIZATION	5
III. GAME OPERATION	5
IV. GAME PLAY AND SCORING	6
V. SOUND	8
VI. GAME ADJUSTMENTS/OPTIONS	8
VII. BOOKKEEPING AND SELF TEST	9
VIII. GENERAL INFORMATION	12
IX. THEORY OF OPERATION	13
X. WIRING AND SCHEMATIC DIAGRAMS	25
XI. PARTS INFORMATION	53

WELLS GARDNER MONITOR, SERVICE AND OPERATION MANUAL (Attached)

WARNING: This equipment generates, uses, and can radiate radio frequency energy and if not installed and used in accordance with the instruction manual, may cause interference to radio communications. It has been tested and found to comply with the limits for a Class A computing device pursuant to Subpart J of Part 15 of FCC Rules, which are designed to provide reasonable protection against such interference when operated in a commercial environment. Operation of this equipment in a residential area is likely to cause interference in which case the user at his own expense will be required to take whatever measures may be required to correct the interference."

WARNING: The Video Disc Player is to be serviced by an authorized Mylstar Electronics, Inc. distributor only! Any attempt to service this unit voids all warranties.

CAUTION: The Video Disc Player must be kept in the horizontal upright position at all times.

When shipping the Video Disc Player to an authorized Mylstar Electronics, Inc. distributor, be certain to replace the shipping screw and bracket and ship in the original box.

Mylstar Electronics, Inc. M.A.C.H. 3 Video Disc Game contains Pioneer LaserDisc™ brand video disc players. LaserDisc™ is a trademark of Pioneer Electronics Corporation and identifies only the video discs and video disc players made by that company.

NOTICE

WARRANTY INFORMATION IS LOCATED ON THE INSIDE BACK COVER.

FOR SERVICE, CALL TOLL FREE: 1-800-323-9121; (ILLINOIS) 1-800-942-1620

I. INSTALLATION



A. SET-UP

1. Unstrap the video disc player from the seat of the player compartment on the SIT-DOWN game or from the top of the cabinet on the UP-RIGHT game.
2. Open the video disc player box and remove the player by lifting from the front and rear of the unit. Place all cables and accessories in the box and store for future use. These items are not used with this game.
3. With the back door open, place the video disc player on the floor in front of the rear cabinet opening with the front of the video disc player facing you.
4. Remove the foam sidings and the plastic bag from the video disc player and store in the video disc players box.

NOTE: All reference to left and right is in relationship to looking into the rear cabinet opening, facing the rear of the CRT.

5. Unravel the video disc player line cord and plug into the outlet labeled VIDEO DISC OUTLET located to the left rear side of the cabinet.

WARNING: Do not plug the video disc player into the CONVENIENCE OUTLET.

6. Be certain the coin door is closed. Plug the game into a 115V AC outlet and turn the game on with the on/off switch located on the lower left back panel.

7. Turn on the video disc player with the on/off switch located on the lower left front panel on the video player unit.
8. Open the top cover of the video disc player by pressing the button labeled REJECT OPEN located directly above the video disc players' power switch. The top will pop up slightly.

WARNING: REMOVE THE SHIPPING SCREW AND BRACKET LOCATED UNDER THE TOP COVER OF THE VIDEO DISC PLAYER IN THE DISC COMPARTMENT WITH A COIN OR SCREWDRIVER BEFORE PLACING THE VIDEO DISC INTO THE DISC COMPARTMENT. Store the screw and bracket in the video disc players' box. REMOVE THE LENS CAP LOCATED TO THE LEFT OF THE SHIPPING SCREW (GREY RUBBER) and store in the disc player box.

9. Remove the video disc from the cardboard shipping sleeve stapled on the video disc player platform. The cardboard shipping sleeve can be used to mail the video disc to an authorized Mylstar Electronics, Inc. distributor for service. Insert the video disc with the aluminum side up into the disc compartment on the spindle post.
10. Close the top cover being certain it locks down
11. TURN OFF THE GAME POWER.

I. INSTALLATION

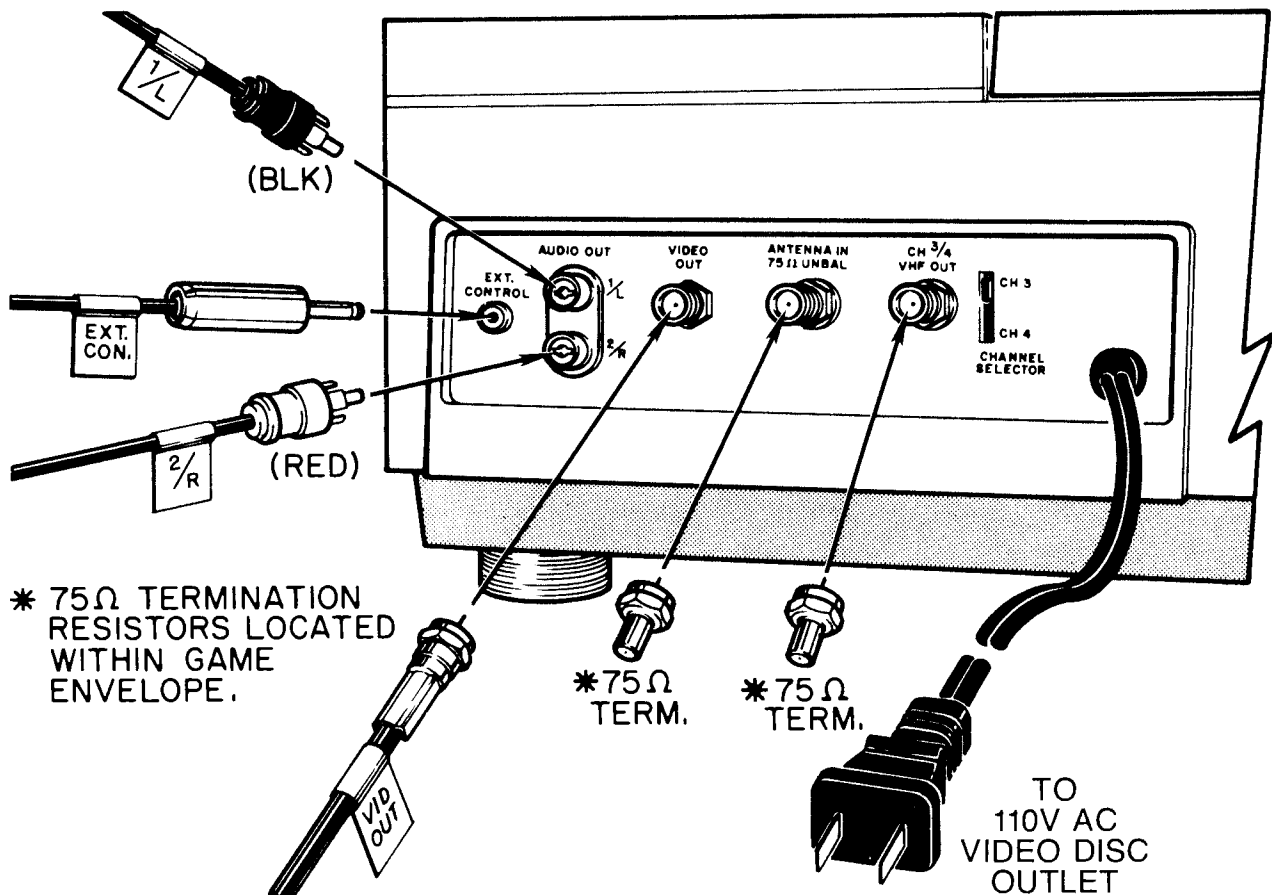

CABLE INSTALLATION

12. Remove the two silver 75 OHM termination caps from the game package and screw them tightly onto the ANTENNA IN 75 OHM UNBAL port and the CH 3/4 VHF OUT port located at the rear of the video disc player. See illustration.
13. Carefully pull the four black cables, located to the right of the video disc platform, out of the cabinet far enough to connect to the video disc player. Do not apply force when pulling on the cables.
14. Place the cable terminated with the F connector (the only connector with threads on the inside) onto the VIDEO OUT port and screw on tightly. NOTE: Be certain that the center pin goes into the center hole on the port. See illustration.
15. Plug the cable terminated with the black RCA plug tightly into the port labeled 1/L. See illustration.
16. Plug the cable terminated with the red RCA plug tightly into the port labeled 2/R. See illustration.
17. Plug the cable terminated with the 1/8" phono plug tightly into the port labeled EXT CONTROL. See illustration.
18. Route all cables to the right side of the video disc platform.
19. Lift the video disc player from the left and right sides

- and place on the video disc platform in the grooves cut out for the feet making certain that the cables do not get routed under the video disc player.
20. Lock the video disc player down with the metal lock-down bracket, placing the bracket from front to rear center of the player with wood screws. NOTE: Complete the B. CHECK- OUT procedure before continuing.
21. Close the back door and turn the game on. MAKE CERTAIN THAT NO CABLES ARE PINCHED IN THE DOOR
22. Be certain that the screen displays the blue disc initialization screen which includes two steps:
 - (1) STOP DISC
 - (2) START DISC
 After disc initialization is achieved, the screen will change to a black background and include one more step:
 - (3) SEEK FRAME (and Display Frame Number).
23. The High Score Table is then displayed.

NOTE: The disc initialization process can take as long as one or two minutes. If screen remains with the Seek Frame picture, refer to Frame Decoder, in the Video Test Section of the game Self-test. (Page 11).

I. INSTALLATION

B. CHECK-OUT

1. Carefully inspect the exterior of the game for any damage which might have occurred during shipment.
2. Unlock and open the rear cabinet door.
3. Check that all plug in connectors are seated firmly. The connectors are keyed so they will only go in one way.
4. Check that all cables are free of the back door.
5. Check for any loose wires.
6. Check for loose solder or foreign matter on switches and power supply assemblies.
7. Be certain all fuses are seated firmly.
8. Be sure transformer wiring corresponds to the supply voltage.
9. Refer to the GAME ADJUSTMENTS section of this manual to make all necessary game adjustments.

C. CONTROL PANEL REMOVAL (SIT-DOWN VERSION)

CAUTION: Before performing the Control Panel Removal, support the Control Pod from the player compartment to avoid the Pod from falling forward on its lower hinges.

1. Unplug the game.
2. Unlock and open the rear cabinet door.
3. From inside the rear of the cabinet, remove two ¼" nuts located on the wall behind the Control Pod.
4. Remove the Control Pod support and rotate the Pod down on its lower hinge.
5. Remove two ¼" nuts from the underside of the Control Pod.
6. Disconnect the Control Panel plugs A8J11/A8P11 and A9J2/A9P2.
7. Slide the Control Panel toward the player compartment.
8. For reassembly, reverse the above procedure.

CONTROL PANEL REMOVAL (UPRIGHT VERSION)

1. Unplug the game.
2. Unlock and open the coin chute door.
3. Reach in through the coin chute door and unlatch the four latches located at the top of the Control Panel.
4. Grasp the Control Panel at the front edge and pull it forward as far as it will go (approximately ¼").
5. The entire Control Panel will now rotate down on its lower hinge.
6. The joystick and leaf-switches are now accessible for removal or cleaning.
7. For reassembly, reverse the above procedure.

D. MONITOR REMOVAL (SIT-DOWN VERSION)

1. Unplug the game.
2. Unlock the front glass with keyed lock located on the upper left outside of the cabinet in reference to sitting inside the player compartment.
3. Lift the front glass up and then out.
4. Remove the CRT frame.
5. Remove the filter glass by lifting up and then out.
6. Remove the four screws from the bottom lens lock.
7. Remove the (Fresnel) lens lock board.

CAUTION: THE LENS SCRATCHES EASILY. PRACTICE EXTREME CARE WHEN HANDLING. AVOID TOUCHING THE RIDGED SURFACE OF THE LENS.

8. Pull the bottom of the lens forward to clear the frame and then pull out. When reinstalling the lens, be certain that the ridges are facing into the player compartment.
9. Remove the monitor mask.
10. Unlock and open the rear cabinet door.

I. INSTALLATION

11. Disconnect the video plug A17J1, the monitor power supply plug A12J3/A12P3 and the ground wires from the monitor chassis.
 12. Remove the four bolts from the underneath side of the monitor shelf.
 13. Remove the monitor from the front of the game, being careful to clear all cables from the CRT neck.
 14. For reassembly, reverse the above procedure. NOTE: Reinstall the lens with the ridges facing the player compartment.
5. On the front of the game, pull down on the lower molding under the marquee. The Speaker Assembly will lower to allow removal of the marquee.
 6. Remove the marquee by lifting it upward out of its track. The Speaker Assembly and Illumination Assembly are now accessible for servicing.
 7. Tilt the front of the Speaker Assembly downward while lifting the center upward. Pull the assembly straight out to remove. Be careful not to pinch the Speaker Assembly cable.

NOTE: The color monitor contains HIGH VOLTAGES delivering LETHAL quantities of energy. Do not attempt to service the monitor until you have shorted the anode plug on the picture tube to ground.

MONITOR REMOVAL (UPRIGHT VERSION)

1. Unplug the game.
2. Perform the control panel assembly removal procedure (Section C).
3. Unlock and open the rear cabinet door.
4. Disconnect the video plug A17J1, the monitor power supply plug A12J3/A12P3 and the ground wire from the monitor chassis.
5. From the Control Panel, remove the one nut and one washer from each of the four carriage bolts used to secure the monitor to the platform.
6. Remove the monitor from the rear of the game, being careful to clear all cables from the CRT neck.
7. For reassembly, reverse the above procedure.

E. SPEAKER ASSEMBLY AND MARQUEE REMOVAL (UPRIGHT ONLY)

1. Unplug the game.
2. Unlock and open the back door.
3. Unplug the A15-J1/P1 connector.
4. Unlatch the two latches on the rear of the Speaker Assembly Panel located inside the back door above the monitor.

8. For reassembly, reverse the above procedure. When replacing the marquee:
 - a. Tilt the front of the Speaker Assembly downward.
 - b. Place the bottom of the marquee in the lower molding track on the front of the assembly.
 - c. Apply slight pressure with your thumbs to the lower left and right corners of the marquee.
 - d. Slowly raise the Speaker Assembly until the top of the marquee is in place in the upper track in the top molding.
 - e. Be certain to reconnect the A15-J1/P1 connector and relatch the rear assembly latches.

F. AIR FILTER REMOVAL (SIT-DOWN VERSION)

CAUTION: CLEAN THE AIR FILTER MONTHLY. The air filter is used to filter out dust particles that could otherwise enter the inside cabinet and damage the game.

1. Unplug the game.
2. Unlock and open the rear cabinet door.
3. The filter and fan are located at the lower left corner by the rear door of the rear cabinet in reference to facing the inside of the rear cabinet. Slide the filter door to the right as far as it will slide.
4. Pull the top of the filter door out and pull the door up to remove.
5. Slide the filter out which is encased in a metal frame.

I. INSTALLATION, II. INITIALIZATION, III. GAME OPERATION

6. Clean the filter in a warm soapy solution.
7. For reassembly, reverse the above procedure. Replace the filter with the grill side facing up.

AIR FILTER REMOVAL (UPRIGHT VERSION)

1. Unplug the game.
2. Unlock and open the rear cabinet door.
3. The filter compartment is located at the center of the cabinet directly behind the back door, the filter compartment door is pulled straight up.
4. Pull the filter straight out.
5. Clean the filter in warm soapy water.
6. For reassembly, reverse the above procedure.

G. MONITOR LENS CLEANING (SIT-DOWN ONLY)

1. Unplug the game.
2. Unlock the front glass with keyed lock located on the upper left outside of the cabinet in reference to sitting inside the player compartment.

3. Lift the front glass up and then out.
4. Remove the CRT frame.
5. Remove the filter glass by lifting up and then out.
6. Remove the four screws from the bottom lens lock.
7. Remove the lens lock board.

CAUTION: THE LENS SCRATCHES EASILY. PRACTICE EXTREME CARE WHEN HANDLING. AVOID TOUCHING THE RIDGED SURFACE OF THE LENS.

8. Pull the bottom of the lens forward to clear the frame and then pull out. When reinstalling the lens, be certain that the ridges are facing into the player compartment.
9. ON THE SMOOTH SURFACE ONLY: Clean with a very mild warm soapy water solution and a clean soft rag.
ON THE RIDGED SURFACE ONLY: Clean with warm water only and a clean soft rag.
10. For reassembly, reverse the above procedure.

SECONDARY MONITOR INSTALLATION

If a second monitor is desired for extended viewing area in an arcade, the second monitor can be installed with the following changes:

1. The secondary monitor must have an isolation transformer to supply 110V AC and chassis ground to the second monitor.
2. On the A18 Color/Sync Board, change resistors R47, R48 and R49 from their current values of 180 OHMS each to 470 OHMS each.
3. Splice the wires going to the secondary monitor as close as

possible to the A17J1 connector on the primary monitor.

If the characters or images on the secondary monitor are blurry or streaking, terminate the transmission wires at the A17J1 connector on the secondary monitor with 180 OHM resistors. To accomplish this, connect a 180 OHM resistor from Pin 1 (Red signal) on the A17J1 connector (on the secondary monitor) to pin 4 (Ground), a 180 OHM resistor from pin 2 (Green signal) to pin 4 and a 180 OHM resistor from pin 3 (Blue signal) to pin 4.

II. INITIALIZATION

TURN GAME ON

The Logic Board enables the video disc player. This process may take as long as one or two minutes. The screen displays the blue disc initialization screen which includes two steps:

1. STOP DISC
2. START DISC

After disc initialization is achieved, the screen will change to a black background and include one more step:

3. SEEK FRAME (and Display Frame Number).

The High Score Table is then displayed.

III. GAME OPERATION

A. GAME START

1. Insert coins into coin chute.
 - a. Coin chute tune is played.
 - b. Total credits are displayed on screen.
2. Press the trigger on the joystick. Move the joystick to

the desired difficulty level, easy, medium or hard. Press the joystick.

- a. Total credits are decreased by one.
- b. Game begins.

IV. GAME PLAY AND SCORING

US VS THEM

HOW TO PLAY

The object of the "Us vs. Them" game is to save the planet from alien invasion. This is accomplished by destroying the core of the alien mothership.

"Us vs. Them" consists of thirteen rounds of play. As the player acts as an observer in "Us vs. Them", there are five different perspectives or points of view the plane is observed in. (1) First Person; (2) Overhead; (3) Bird's-eye; (4) Profile; and (5) Reverse. The play action is a little different in each of the five types and will be explained in detail.

CONTROL PANEL

The joystick controls the movement of the players plane. It can be moved in eight directions. The trigger on the joystick will fire two fireballs simultaneously, one from each wing of the plane.

The buttons on the Control Panel as well as the buttons on the joystick, can be used for either banking the plane left or right, or firing the machine gun forward or reverse. These actions will be determined by the different type of game being played.

ROUND	POINT OF VIEW	PILOT	LOCALE
1	First Person	Mean Green	Canyon, Water or Clouds.
2	Overhead	Sky Blue	Desert or Farmland.
3	First Person	Big Red	Forest.
4	Profile	Quick Silver	Clouds, Hills or Canyon.
5	First Person	Quick Silver	Mothership (Tunnel).
6	Bird's-eye	Mellow Yellow	San Francisco, San Diego or Hollywood.
7	Profile	White Knight	Hawaii, Chicago or San Francisco.
8	Reverse	Mean Green	River or Farmland.
9	First Person	Quick Silver	Mothership (Tunnel/Force field).
10	Profile	Sky Blue	Cliffs or Houses.
11	First Person	Big Red	Forest.
12	Bird's-eye	Mellow Yellow	Chicago.
13	First Person	Quick Silver	Mothership (Force field)

IV. GAME PLAY AND SCORING

TYPES OF GAME PLAY

(1) First Person; Six rounds of "Us vs. Them" are played in the First Person perspective. When firing during these sequences all shots are drawn inwards. The aliens will not collide with the player's plane but will fire laser blasts that spiral towards the player and must be avoided.

During the Forest Rounds, the alien ships fire double shots which use some unknown alien technology to track the players plane. These shots cannot be avoided and the player must bank appropriately to escape collision.

Later, during round five, the player is inside a tunnel in the Mothership which contains energy walls. The player must avoid these by flying through the holes in the walls. Failure to do so will result in collision. If the mission is successful, bonus score is added dependent on the difficulty of entry.

In Round Nine the player encounters a Force field. As many pieces of the field must be shot away as possible before the round is over. The player returns to the Force field during Round Thirteen and must destroy all remaining pieces before the timer runs out in order to enter the core of the alien Mothership.

(2) Overhead; and (3) Bird's-eye; Both of these types of play are

similar in nature. When firing, all shots aim straight ahead. The buttons on the Control Panel can be used to change direction of fire to forward or reverse.

The alien ships during these sequences will collide with the player but will not fire at the player's plane.

(4) Profile; Game play during the Profile perspective consists of two distinct types of alien aircraft. The first type can drop bombs on the player from above or from below. The second type of alien aircraft will bob back and forth trying to outmaneuver the player. This alien ship will not fire at the player but can collide.

(5) Reverse; The alien ships will double fire at the player. The shots cannot be avoided and the player must bank appropriately to escape collision.

ENDING THE GAME

The game ends when the player runs out of Shield Power. Shield Power is lost two ways.

- a. Major loss-receiving alien fire.
- b. Minor loss-colliding with, alien ships, energy walls or trees.

Extra Shield Power can be obtained automatically after Rounds Four and Eight, or by shooting down Hedrons.

SCORING

- * Most alien ships score 100 points.
- * Two pod ships (during Round One only)
 - a. When hit together, score 1000 points.
 - b. When first pod hit, score 100 points.
 - c. When second pod hit, score 500 points.
- * Hedrons score 5000 points.

- * End of round bonus is equal to;
All Rounds
Difficulty level bonus + [# ships destroyed x {base bonus - (# hits x 25)}].
- Energy Wall Rounds
If no walls are hit, scores 10,000 points, otherwise zero.

V. SOUND, VI. GAME ADJUSTMENTS / OPTIONS

V. SOUND

The Sound Board in this game has been programmed for sound and speech. This Sound Board cannot be replaced or exchanged with any other Sound Board.

VI. GAME ADJUSTMENTS/OPTIONS

A. CONTROL BOARD SWITCH ADJUSTMENTS

SWITCHES

1	2	COIN/CREDITS
OFF	OFF.....	1 / 1
ON	OFF.....	2 / 1
OFF	ON.....	FREE PLAY
ON	ON.....	FREE PLAY

SWITCH 4	DIFFICULTY CONTROL
OFF.....	NORMAL
ON.....	HARD

SWITCHES 3,5,6,7 & 8 ARE NOT USED IN THIS GAME AND MUST BE IN THE OFF POSITION.

NOTE: Control Board switch settings may vary outside the United States.

B. SOUND ADJUSTMENTS

The audio output is controlled by the potentiometer mounted on the service panel assembly (located inside the coin mechanism door).

Turning the potentiometer counter-clockwise will decrease the volume. Turning it clockwise will increase the volume.

C. MONITOR ADJUSTMENTS

Normally, few if any adjustments are required for proper monitor operation. However, after any major repairs to the monitor chassis refer to the attached monitor manual.

WARNING: The Shield Top covering the Master Electronics Panel will have to be removed in order to make some adjustments to the printed circuit boards. This cover is used, in part, to comply with the limits for a Class A computing device pursuant to Subpart J of Part 15 of FCC Rules. Failure to replace the Shield Top over the Master Electronics Panel when the game is in operation voids all warranties.

VII. BOOKKEEPING AND SELF TEST

SELF TEST

The self-test consists of five functions which may be used to identify problems in the video disc system and to change program parameters.

The self-test mode is entered by setting the self-test toggle switch located inside the coin door to TEST. A menu of available tests are displayed on the monitor. To return to the GAME mode at any time, set the toggle switch back to GAME.

The game will then re-initialize the video disc and return to its normal attract sequence.

Selection of tests is done with the push button switch labeled SELECT. Upon entering the test mode, a flashing arrow points to the first test selection. Momentarily depressing the SELECT button will advance the arrow through each selection one by one.

When the arrow is pointing to the desired test, the operator may begin that test by pressing the SELECT button and holding it down until the test appears on the screen.

Once a test has been selected, the operator can return to the main menu by holding down the SELECT switch until it re-appears. The five tests are as follows:

1. CONTROL PANEL

Colored squares are shown for each switch input, including both panel buttons, the slam switch and the trigger on the joystick. An open switch is shown as blue, while a closed switch is shown as yellow. The joystick switches are displayed as four blue squares in the bottom right corner of the screen forming a diamond. Movement of the joystick will cause the appropriate square to change color. Pushing the joystick at an angle will cause the two appropriate squares to change color to yellow. The slam switch indicator should normally be yellow, if not, the game will not run.

For each coin mechanism, a digit is displayed (initially 0). Inserting a coin into a coin chute will increment the appropriate value without affecting the coin meter.

2. DIP SWITCH SETTINGS

A functional description of the eight position

Dip Switch located on the Logic Board Assy, underneath the far right side of the Interface Board is displayed. Changing the switch settings will cause an immediate update of the description displayed on the screen. All of the possible switch combinations are shown. Any switch that is "ON" is displayed by a one, and any switch that is off is displayed by a zero. The arrows indicate the current switch settings.

See VI. GAME ADJUSTMENT/OPTIONS A. CONTROL BOARD SWITCH ADJUSTMENTS.

3. BOOKKEEPING

Selecting this test will display a menu of six functions. Pushing the SELECT button momentarily will move the arrow on the screen to the desired function. When the arrow points to the desired function, hold the SELECT button down until that function is displayed.

DISPLAY SCORE COUNTS--A number of tables based on how many times players used the add-a-coin feature can be viewed. Each table is also categorized by the three difficulty levels, easy, medium and hard. To clear the table, press either button on the control panel and return to the menu by holding down SELECT.

DISPLAY TIME COUNT--Same as above except each category represents play times in seconds. The average time is given in minutes and seconds.

DISPLAY ROUND COUNTS--Same as the Score Count tables except each category represents what rounds were achieved per game played.

RESET HIGH SCORES--Selecting this test will reset the high score table.

CLEAR COIN COUNT--Selecting this test will reset the coin count to zero.

VII. BOOKKEEPING AND SELF TEST

RESET "HERO" SCORE--When a player reaches the end of the game (Round 13), his name is entered in a special high score table, displayed during the attract mode (if no player has reached the end of the game, the regular high score table is displayed). To clear the table, press either button on the control panel and return to the menu by holding down SELECT.

4. HARDWARE TESTS

Selecting this test will display a menu of four functions. Pushing the SELECT button momentarily will move an arrow on the screen. When the arrow points to the desired function, press the SELECT button and hold it down until the test appears.

MONITOR ADJUSTMENT — Four patterns can be displayed on the screen for adjusting monitor color, brightness, contrast and convergence. The patterns are: color bars, a cross-hatch, a gray scale and a dot pattern. By momentarily pressing the SELECT button, the four patterns may be cycled through.

MEMORY TEST — For each RAM memory chip: an OK or an NG (no good) appears signaling that the chip is good or bad respectively.

Check sums are displayed for each ROM memory chip. If you have a suspect ROM, refer to your distributor for the correct check sum number.

SOUND TEST--After selecting this test, a count will appear on the screen representing the various sounds that are produced by the game. All the different sounds will be produced and the screen count will repeat to 01. Pressing either button on the control panel will suppress all sound output and speed up the count so a particular sound can be investigated.

FOREGROUND BANK TEST--Selecting this test will display a choice

of, two planes and a circle, or two planes and two alien ships. Pressing the left or right panel buttons will toggle between the two.

5. VIDEO TESTS

Selecting this test will display a menu of four functions. Pushing the SELECT button momentarily will move the arrow on the screen. The selected test will automatically begin when the arrow is pointing to it.

NOTE: If the game has been powered up in the test mode, the SPIN DISC UP function under COMMAND CONTROL may need to be performed. See COMMAND CONTROL below.

GEN LOCK TEST — Selecting the GEN LOCK TEST will display a menu of three functions.

(1) GRAPHICS ONLY — This test shows the computer display only. There is a blue background with the computer generated color bars and foreground objects showing only. The foreground objects are within the color bars.

(2) DISC AND GRAPHICS — This test shows the computer display foreground and the disc display background. The computer generated foreground objects are seen against the video disc background. Be sure the foreground objects are clear and that all computer generated color patterns are close in hue to the disc generated frame. To adjust the disc generated background color, adjust the following on the Color/Sync Board: R37 (tint adjust), R38 (color saturation adjust), R27 (brightness adjust), or R35 (contrast adjust).

(3) NO VIDEO — This test shows a dark screen displaying no video.

VII. BOOKKEEPING AND SELF TEST

COMMAND CONTROL — Selecting this test will display a menu of two functions.

Pushing the SELECT button momentarily will move an arrow on the screen. When the arrow points to the desired function, press the SELECT button and hold it down until the test appears.

(1) REPEATED STEP FORWARD — After selecting this test, the disc will step forward one frame repeatedly and also triggers the Sound Board to produce a 2.5 KHz pulsing tone when R22 (clock burst adjust) on the Interface Board is adjusted properly. If the disc does not step forward check the cables connecting to the Interface Board for correct placement and a tight fit and check the EXT CONTROL cable connected to the rear side of the video disc player. If the disc still does not step forward, adjust R22 on the Interface Board until the 2.5 KHz pulsing tone is heard.

(2) SPIN DISC UP — Selecting this test initializes the disc. This prepares the disc for video tests if the game was powered up in the test mode. The initialization automatic sequence is as follows: (a) the disc is brought to a halt, (b) the disc is spun and brought up to operating speed, (c) the system seeks out frame #1.

FRAME DECODER — Selecting this test will display a menu of two functions. Pushing the SELECT button momentarily will move an arrow on the screen. When the arrow points to the desired function, press the SELECT button and hold it down until the test appears.

(1) STILL FRAME DECODER — After selecting this test, the video disc player seeks any frame #. The number in the upper left corner of the screen is the actual current disc frame number. Directly below it is the current frame number the computer recognizes. The two numbers should match. When they do, the Sound Board is triggered. This allows adjustment of R204 (frame number level) on the Color/Sync Board.

Adjust R204 until a constant uninterrupted beeping tone is heard. This constant tone will indicate that R204 is adjusted correctly.

(2) PLAY FRAME DECODER — This test is the same as the STILL FRAME DECODER test except the disc is playing, and the beeping rate is faster. Adjust R204 on the Color/Sync Board until a constant uninterrupted beeping tone is heard again.

VIII. GENERAL INFORMATION

A. PRINTED CIRCUIT BOARDS ARE DESIGNATED AS FOLLOWS:

- A1 Logic Board Assy.
- A2 Interface Board Assy.
- A3 Power Supply Assy.
- A6 Sound Board Assy.
- A8 Filter Board (I and II)
- A18 Color/Sync Board Assy.

B. WIRE COLORS ARE SHOWN AS NUMBERS:

0 Black	5 Green
1 Brown	6 Blue
2 Red	7 Purple
3 Orange	8 Gray
4 Yellow	9 White

For example, 688 is a Blue - Gray - Gray striped wire.

C. FUSES

BOTTOM PANEL

F1	115V AC 60 Hz (Primary Power)	4 Amp
F2	6.3V AC (Coin Chute Lamps)	1 Amp
F3	Monitor	2 Amp SLO-BLO
F4	9V AC (+5V DC)	12 Amp SLO-BLO
F5	15V AC $\left(\begin{array}{l} +12V DC \\ -12V DC \end{array} \right)$	2 Amp SLO-BLO
F6	15V AC $\left(\begin{array}{l} +20V DC \end{array} \right)$	2 Amp SLO-BLO
F7	Audio Amplifier Supply	1.5 Amp SLO-BLO
F8	Fan	1/4 Amp SLO-BLO
F11	9V AC ($\overline{\text{RESET}}$)	1/4 Amp SLO-BLO

CABINET FUSE

F9	Video Disc	2.5 Amp SLO-BLO
F10	Rear Fan	1/4 Amp SLO-BLO
F12	INPUT LINE FUSE	8 Amp SLO-BLO

IX. THEORY OF OPERATION

SYSTEM OVERVIEW

Mylstar Electronics, Inc. Video Disc Graphics System is a character based system controlled by the Intel 8088 16-bit microprocessor for state of the art design. The graphics state machine is driven by a 10 MHz clock derived by dividing down a 20 MHz crystal or from the VCO (Voltage Controlled Oscillator) on the Color/Sync Board. The foreground generator can drive 63 individual, independent objects whose size is 16 pixels by 16 lines, selectable from 256 foreground objects, at any frame time. All of these objects have their own level of priority, which means that there are 63 planes of depth. A double line buffer is used to drive the video information.

The background generator is character oriented. The characters are determined by an 8 pixel by 8 line matrix, which can be selected from a 128 character set (when RAM is used for the character generator) or from a 256 character set (when ROM is used instead). Both background and foreground objects can be displayed with 16 different colors selected from a total of 4096 possible colors during any given frame time. The dot resolution of the system is 256 pixels by 240 lines.

All horizon and target information is encoded for each video frame and stored on audio channel 2 of the video disc. During game play, the video frame decoder reads the frame number from the video on the video disc so that the computer system knows exactly what frame is being displayed. Knowing the frame number, the computer system accesses the target data buffer describing object position and/or nature of that particular frame target.

Mylstar Electronics, Inc. utilizes a Pioneer LaserDisc™ brand video disc player and reflective disc. The video disc has encoded composite video information including picture, synchronized pulse and audio data. The pulse data identifies a unique frame number pre-assigned to each video frame.

The video disc player also produces two completely discreet audio channels from the audio data on the reflective disc. Audio is stored on channel 1/L while target data is stored on the channel 2/R.

The audio channel one is routed to an audio summer on the Sound Board while the audio channel two is routed to the audio decoder on the Interface Board.

The composite video signal is sent to the sync separator (U10) and to the color decoder (U1) on the Color/Sync Board. The color decoder decodes the chrominance and luminance from the composite video signal and produces an RGB signal.

The RGB output from the computer system and the RGB signal from the video disc are multiplexed (U2) and sent to the monitor.

The composite video signal from the video disc is asynchronous with the rest of the system, especially the video produced by the computer system. The composite sync is separated from composite video by the sync separator to produce the horizontal and vertical synchronization signals. The sync separator produces an external vertical sync pulse, $\overline{VDV SYNC}$, which resets the vertical counters causing vertical synchronization between the computer graphics image and the video disc image. The sync separator also produces an external horizontal sync signal, $DH SYNC$, which is coupled to a phase comparator (U6) of a phase locked loop (PLL) circuit also on the Color/Sync Board. The PLL also includes a voltage controlled oscillator (VCO) (U5).

Besides the $DH SYNC$, the phase comparator also receives a horizontal synchronous signal, $H BLANK$, which is related to the system clock of the computer graphics system. The comparator compares both signals for phase and frequency differences and produces a difference signal. The difference signal is filtered by the loop amplifier and sent to the VCO. The VCO then generates a signal, $DISC CLK$, which becomes the system clock of the computer graphics system.

BOTTOM PANEL ASSEMBLY

The input AC line voltage is filtered and wired to the 115V AC primary winding tap and the common tap of the transformer on the Bottom Panel. The secondary winding supplies five separate voltages. The isolated 115V AC supplies the monitor voltage as well as the Illumination Assembly voltage (where applicable).

The 9V AC RMS winding is full wave rectified and filtered to +11.5V DC average voltage. It is directly routed to the Power Supply via the Filter Board. The 6.3V AC RMS fused winding is sent to the front door to operate the coin chute lights. The

IX. THEORY OF OPERATION

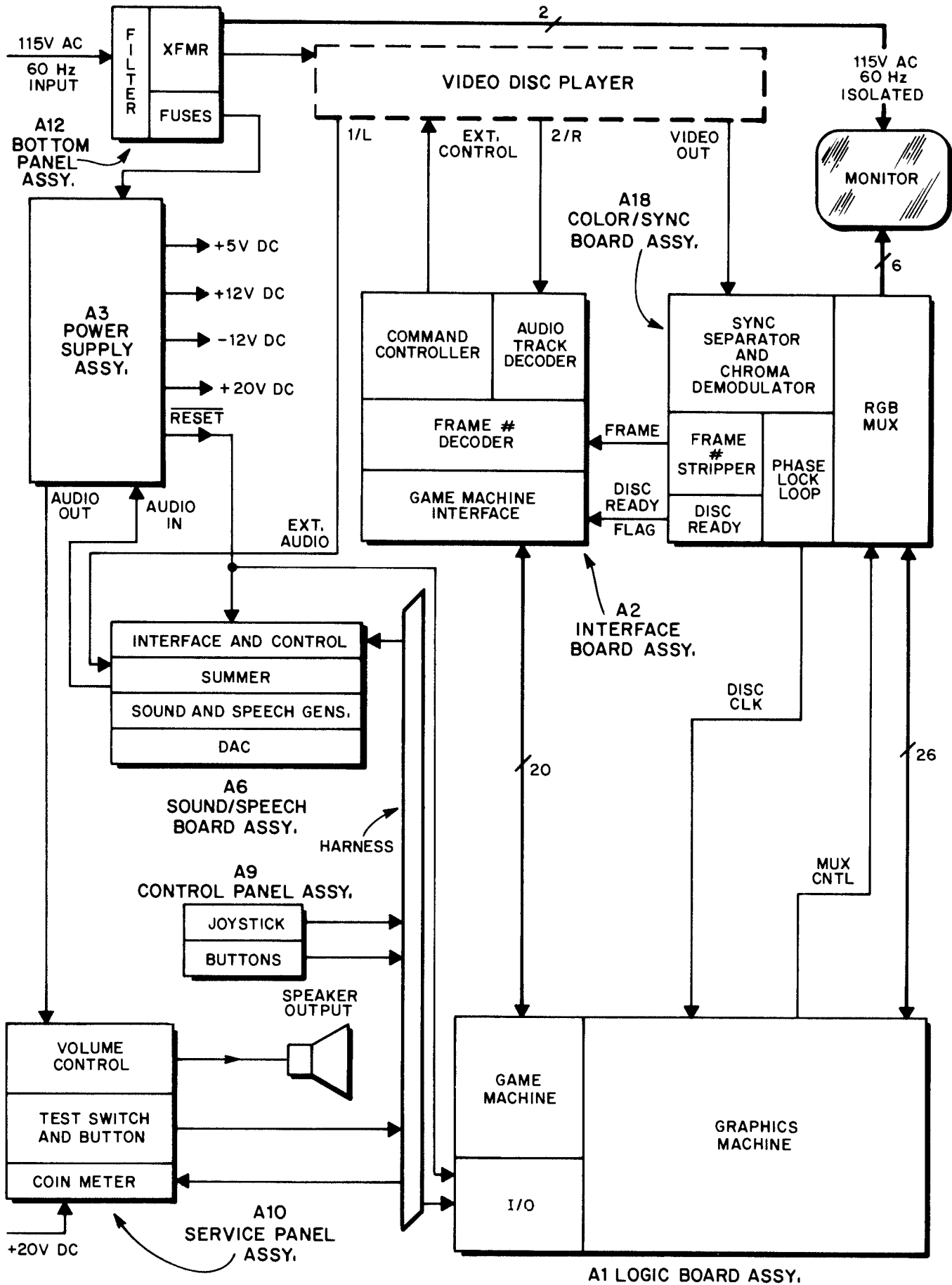

SYSTEM BLOCK DIAGRAM

IX. THEORY OF OPERATION

15V AC as well as the 9V AC windings are both routed directly to the Power Supply via the Filter Board.

POWER SUPPLY ASSEMBLY

The Power Supply, used to supply all voltages, is extremely tolerable to input line voltage variations. All output source voltages are guaranteed to be stable for line voltages varying from 95V AC to 135V AC 60Hz. The regulated logic +5V DC level is rated at 6 amps maximum and includes over-voltage crowbar protection. Four LED's on the Power Supply Board indicate that the associated voltages at the outputs are present.

The +11.5V DC entering the Power Supply Board is regulated to +5V DC by Q11, Q12 and U11 and is adjustable by VR1. R15 and VR1 along with R16 divide the regulator output voltage to +2.5V DC at the reference pin of U11, the programmable zener. As the output voltage rises, the voltage on the reference pin on U11 will rise. To compensate for the rising output, U11 draws more current away from the base of Q12. This in turn turns off Q11 which drops the output voltage. As the output voltage of the regulator falls, the reference pin voltage falls, turning off U11. This will increase current flow through Q12 which in turn will increase current from the emitter to collector of Q11, raising the output voltage.

The over-voltage crowbar circuit mentioned earlier consists of C14, D12, R17, R18 and the SCR. The SCR requires 1.4V gate to cathode in order to turn on. The zener is rated at 5.6V. Therefore a voltage of 7V on the +5V DC line will trigger the SCR (7V-5.6 rated zener volts =1.4V). Once the SCR is on, the +5V DC line is shorted to ground, causing the fuse to open, preventing over-voltage damage to the TTL. R17 is a current limiting resistor for the SCR and R18 is the zener resistor. C14 filters out spikes that could trigger the SCR.

The 12V AC RMS is rectified and filtered and supplies the Audio Amplifier, LM2002, with unregulated +12V DC. The input Audio comes in on pin 3 of P7 and is 5V AC peak to peak (to keep a good signal to noise ratio). This signal is attenuated by R51 and R52 by fifty times and is fed to C52, the amplifiers input.

The 220 ohm R54 and 2.2 ohm R55 set the closed loop gain of the LM2002 by the equation

$A_v=1+R220/R2.2=101$. Therefore the overall system gain is $101/52=1.94$. R53, C55, R56 and C57 are compensation networks at 1 MHz and 10 MHz to keep the LM2002 unconditionally stable. C54 is the low frequency feed back capacitor. C58 is the output capacitor blocking the DC bias of the amplifier so that the output voltage on the speaker can swing above and below ground. The output appears at pin 4 of P6.

The center-tapped 15V AC RMS is utilized to supply three voltages. It is full wave rectified by D41 and D42 in order to supply the +20V DC average voltage used for the coin meters. It is also full wave rectified by D31 through D34 in order to supply the plus and minus 12V DC. The positive side of the bridge feeds the LM340K (U31) +12V DC regulator at 1 amp, while the negative side of the bridge is sent to the LM320 (U41) which regulates the -12V DC at 0.1 amp. D36 and D44 are used as protection diodes in the event that the output or the regulator exceeds the input.

POWER SUPPLY RESET CIRCUIT

The Reset Circuit provides graceful power-up and power-down for the processors on the main Logic Board and Sound Board. It does this on power-up by holding the processors in reset until the +5V DC has settled and on power-down halts the processors before the +5V DC has begun to collapse. D71 through D74 full wave rectify the AC voltage that feeds the +5V DC regulator. This full wave non-filtered voltage retriggers U71 at pin 4, the CMOS monostable, until the line voltage is removed. On power-up the full wave voltage charges C75 through R74. Until the voltage on C75 reaches the CMOS logic high threshold, the monostable U71 is held reset. This holds the processor reset to allow time for the +5V DC logic supply to settle.

Q71 and Q72 amplify and translate the CMOS level to drive multiple TTL loads.

D75 and C72 make up the power supply for the monostable from the full wave voltage.

R72 and C73 make up the timing components for U71 and are set for approximately 11 ms.

LOGIC BOARD ASSEMBLY

A 5 MHz dot clock drives a 9-bit Horizontal dot Counter (S16, S17 and T17) and an 8-bit Vertical Line Counter (G17 and K16). The horizontal counter

IX. THEORY OF OPERATION

counts from 0 to 255 during active scan lines and 256 to 317 during the horizontal blanking time. When the horizontal counter reaches 317, it resets to zero. At the beginning of the horizontal blanking time (horizontal counter=256), it increments the vertical counter. The vertical counter counts from 0 to 239 during active vertical blanking time.

The watchdog timer (A3) will reset the microprocessor unless it receives a pulse through the output port (B9) at least every 256 msec. The BLANK signal is generated from T14 pins 2 and 3. Pin 2 is the VBLANK input and pin 3 is the HBLANK inputs. VBLANK is produced when G17 reaches its maximum count or when the video disc VDV SYNC presets the outputs of G17 high. H17 then generates a low because all of the G17 outputs are high. Multiplexer V15 selects which VBLANK signal is inverted by T15 and sent to pin 2 of T14. The HBLANK is generated by pin 14 of T17 which is the most significant bit of the horizontal counter. The BLANK signal is inverted by K17 which turns on Q81 providing +5V DC to the emitters of Q82 through Q87, the color output transistors.

The 20 MHz crystal divided by two is the crystal system clock signal generated at pin 5 of V14. Multiplexer V15 selects between the crystal system clock and the video disc VCO clock. This signal becomes the CLK signal which clocks all of the logic timing and produces the HCLK signal from pin 9 of V14 which clocks the horizontal counters and latches.

Foreground generation on the System is initiated with three foreground registers (H1, H2 and H4) all addressed via the microprocessor through program control. These registers are the Foreground Horizontal Position Register (H1), the Foreground Object Select Register (H2) and the Foreground Vertical Position Register (H4).

When the appearance of an object is required on a scan line, as detected by the Vertical Position Detector, the address generated by the Foreground Horizontal Position Register is copied into the Line Object Position RAM (N1-N4) and the address generated by the Foreground Object Select Register is copied into the Line Object Select RAM (S1-S6). The Line Object Position RAM contains the horizontal position of the object for the next scan line while the Line Object Select RAM contains the

address for the Object ROM to address the desired object.

Since the foreground object size is 16 pixels by 16 lines, the Vertical Position Detector must generate enable pulses for 16 successive lines. The high order 4 bits of the Foreground Vertical Position Register and the Vertical Counter are summed (H5) and feed the Line RAM Enable Pulse Generator (H6 and S8). When the sum values of H5 are all high, the write enable is generated. This pulse enables the transfer of data from the Foreground Horizontal Position Register to the Line Object Position RAM as well as the transfer of data from the Foreground Object Select Register to the Line Object Select RAM via the read/write (WR) signal (FBA4) and the chip select (CS) signal (S2) from the multiplexer (M9). For each pulse generated, information for the next scan line is loaded into the Line RAM.

When the Line RAM Enable Pulse Generator generates a pulse, it increments the 5-bit Line RAM Address Counter. This counter produces the addresses for the Line Object Position RAM's. When the Line Object Position RAM is being read, the 8-bit Line Buffer Address Counter (N5 and N6) is loaded (every 1.6 usec). Before any new horizontal information can be loaded into the Line RAM, the counter must increment 16 times in order to address the 16 pixels that the foreground object will occupy that frame time.

The low order 4-bits of the Foreground Vertical Position Register and the Vertical Counter are summed (K5) and address the object information to the Foreground Object ROM (T4, T5, T6 and T8) via the multiplexer (M5) and the Object ROM Address Latches (T1-T3). The Foreground Object ROM's receive their addressing from three sources: (1) the high order 8-bits from the Foreground Object Select Register, (2) 4-bits from the Vertical Position Detector and (3) the least significant bit (RA0) comes from the 800ns counter (V12). This counter will output every 4 clock cycles. The information out of the Object ROM's is loaded into four parallel to serial shift registers (V4, V5, V6 and V7). Every clock cycle the outputs of the four shift registers are checked for data. If any output data, a write enable pulse (T12, T13 and T9) is generated allowing data to transfer to the Line Object Buffers. The Background Character Registers (H7) data is

IX. THEORY OF OPERATION

copied into the Background Buffer RAM (H10) during the first half of the vertical blanking time through DMA transfer (H9). Once the data is read by the Buffer RAM, the Character Register is ready to be loaded with new information. The data in the Buffer RAM is an 8-bit object number. This object number addresses the Background Character ROM (H12 and H13) which contains pixel definition for the background character. The Character ROM will output 8-bits of information for two pixels for the 8 pixel by 8 line character. The horizontal counter, H1 and H2, and the vertical counter, V0, V1 and V2, are used so that the background object is displayed at the correct vertical and horizontal positions on the screen for each frame.

The dual line buffers are 256 x 4-bit RAM which contain one scan line of foreground object information. While one line buffer is loaded for the next scan line, the other is being read. These 4 bits of information form the foreground video output.

Pin 2 of A8 (F/B priority signal) is used to choose the dominance between foreground and background objects in the video arbitrator which consists of N11 and S12. A high on multiplexer N12, pin 10, will give background priority while a low gives foreground priority. The inputs to both 5-input NOR gates of N11 are the 4-bit color numbers needed to color one pixel. All colors have priority over color zero. If either of these pixel color numbers are zero, then a logic high is produced at the output of the NOR gate. N11, pins 5 and 6, are fed to the inputs of N14 (NAND gate) and then latch at dot time by V9 (D flip flop). Only when both the background and the foreground colors are zero, will the output of V9 be a logic low. This signal is sent to V15 (multiplexer) and becomes MUX CNTL. When MUX CNTL is a logic low, the video disc's RGB is selected. When MUX CNTL is a logic high, the computer graphic RGB is selected.

The code to be used for the pixel is transferred to the color registers M13, M14 and M15. The color register package is 16 x 12-bits (4-bits for red, 4 for blue and 4 for green). The registers are loaded with the 4-bit color code during the vertical blanking time only. The selected 4-bits by the foreground/background arbitrator is the address for the color RAM. In other words, it is not the data for the picture, but the location of the desired

color. The color registers output is sent to the monitor through the D to A converter which consists of R93 through R104 and Q82 through Q87.

COLOR SYNC BOARD

The Color/Sync Board has 6 major functions:

- 1) Sync separation of DH SYNC and DV SYNC from the video disc.
- 2) Strip the frame number from composite video and convert it to a TTL compatible signal.
- 3) Composite video to RGB from the video disc.
- 4) Multiplexing of video disc RGB and Graphics RGB.
- 5) Phase Lock Loop to adjust Graphics System Clock so that the video discs DH SYNC and Graphics H SYNC (H BLANK) match in phase and frequency.
- 6) Generation of video disc Ready Flag.

SYNC SEPARATOR

1V_{pp} composite video from the video disc player comes into J5 via a 75 ohm coax cable through C1 to an inverting amplifier (Q1 and Q2) with a gain of 5. This 5V_{pp} composite video is DC restored with C4, R9 and CR102. The DC restored video is sent to a dual high speed comparator(U10) so that composite sync and the frame number are stripped from composite video. The composite sync is sent to U7 to remove the vertical serrations for the PLL, also to an inverter and then an LRC network consisting of R12, L1, C7 and C10 which delays the HSYNC so as to line up with the Chroma burst signal needed by the Chroma Demodulator (U1). Composite sync is also sent to R100, C17, R15 and C8, which is the integrator to separate DV SYNC. Q4 and Q104 are the vertical sync amplifiers.

STRIP THE FRAME NUMBER

The video frame number decoder includes a frame number stripper (U10) that receives the composite video signal. Potentiometer R204 adjusts the comparator voltage level. The stripper also receives the horizontal and vertical sync information contained on the disc, the DH SYNC signal and the DV SYNC signal. The DV SYNC resets the D flip flop (U9), therefore enabling the output of the high speed comparator (U10) at the next DH SYNC pulse. When the output of the comparator goes high, the D flip flop (U9) will set and

IX. THEORY OF OPERATION

therefore disables the comparator output at the next DH SYNC pulse. Because the 24-bit Phillips frame number code is only present during the odd field of vertical blanking, every other series of pulses will be the 24-bit code. The output from the stripper is fed to J7 and then to the Interface Board which detects the frame number and stores it in latches for game machine use. By using the test mode in the game, the frame number decoder can be adjusted via potentiometer R204.

COMPOSITE VIDEO TO RGB FROM THE VIDEO DISC

Before explaining this portion of the board, a few words should be defined:

Chrominance — The colorimetric difference (dominant wavelength and purity) between any color and a reference "white" of equal luminance. In other words, the color information in the television picture.

Luminance — Luminous intensity reflected or emitted by a surface in a given direction per unit of apparent area. In other words, the black and white portion of the television picture.

Composite video from J5 passes through C101 to the inverting amplifier with a gain of 3 consisting of Q101 and Q102 and associated components. This signal is sent through R19 to a 3.58 MHz trap consisting of L2 and C110 to remove the chrominance signal from composite video leaving only the luminance signal to pass through L4, DL1, L3 and C26 to U1, the Chroma Luma-Processor.

The inverted composite video from Q102 is also sent through R21 and C22 to T1, a 3.58 MHz bandpass transformer. This removes all luminance information from composite video leaving only the Chrominance to pass through C24 to U1, the Chroma-Luma Processor. The chrominance signal passing through the bandpass transformer is delayed in time. This delay is compensated by the Delay Line, DL1, so that the luminance signal arrives at U1 at the same time the chrominance signal does.

The Chroma-Luma Processor decodes the composite video to RGB appearing at pins 26, 27 and 28 respectively. These signals are restored and sent to the Analog multiplexer (U2) to be multiplexed with the RGB from the graphics system.

ANALOG MULTIPLEXER

The Analog Multiplexer multiplexes the RGB from the graphics system and the RGB from the decoding of video disc composite video. The Analog Multiplexer is controlled by the signal MUX CTRL from the Graphics Board via J2. This signal is delayed slightly to compensate for the access time of the color RAM and the D to A conversion on the Logic Board.

PHASE LOCK LOOP

Phase Lock Loop (PLL) circuitry is generally made up of a phase comparator, loop filter and a VCO (Voltage Controlled Oscillator). The phase comparator (U6) compares the phase and frequency of two digital signals and produces an error signal at pins 5 and 10. The loop filter composed of Q202, R43, R43A, C40, C21, R45 and R44 filter the digital error signal to a DC value the VCO can use. The VCO (U5) takes a DC voltage at pin 2 and produces a TTL compatible frequency at J1. This frequency is the system clock for the graphics state machine. The graphics state machine clock is divided down via TTL counters to produce H BLANK which is sent to one of the inputs of the phase comparator (U6). This closes the loop for the PLL. The reference frequency to the phase comparator is DH SYNC, which is the horizontal synchronization signal stripped from the video disc composite video.

The action of the PLL is to adjust the graphics system clock frequency at J1 to eliminate the phase and frequency difference between the graphics system H BLANK and the video discs DH SYNC. This is what makes the overlay of the computer generated graphics over the video disc background possible.

If the H BLANK signal received by the phase comparator from the computer system is slower than that received from the sync separator from the video disc, the difference signal fed to the VCO forces the VCO to speed up, and vice versa. This produces signals from the video disc and the computer system that are synchronous so that the two can be multiplexed for display on the monitor.

GENERATION OF THE DISC READY FLAG

The Disc Ready Flag tells the program logic that valid composite video is being produced from the video disc player. This signal is produced by using DV SYNC (the vertical sync pulse stripped from

IX. THEORY OF OPERATION

composite video) to trigger a retriggerable monostable(U4). If DVSYNC is present with a 16 msec period, the Disc Ready Flag will be high.

PULSE SHAPING OF $\overline{\text{VDV SYNC}}$ SIGNAL

The video disc produced image is larger vertically than the computer graphics image. The monostable (U7) produces a pulse width from DV SYNC which places the graphics image vertically in the middle of the video disc image. If no pulse is on the output of pin 12 of U7 when Gen Lock is called for, the picture will roll vertically.

INTERFACE BOARD

The Interface Board is the game machines interface to the video disc player. The board's four functions are:

- 1) Frame number decoder
- 2) Audio track decoder
- 3) Command controller
- 4) Game Machine Interface

FRAME NUMBER DECODER

The 24-bit Phillips Frame Number Code is stripped from the video and is received at TTL levels from the Color/Sync Board on J3. The frame number code is squared up and inverted by A2 (Schmitt inverter). This signal is sent to a network of C29, R30 and A2 (positive edge detector), an inverter and another positive edge detector. These voltage spikes are summed by A4 (NAND gate) so that B4 can strip the clock of the frame data. The positive and negative edge voltage spikes are also inverted by A3 and summed with the clock to set up Set and Reset pulses for the D flip flop (B3). The D flip flop strips the data from the frame number signal for the shift registers B1, G1 and H1. The four input NAND gate detects a valid frame number and produces the clocking signal that latches the frame number into the latches B2, G2 and H2. The frame number is then read into the game machine via the data bus and strobes IP5, IP6 and IP7.

AUDIO TRACK DECODER

The audio track decoder on the Interface Board, receives the data from the audio channel 2. It decodes the signal to extract digital data, and stores data in RAM until the computer system is ready to read it. The audio track decoder includes an edge comparator (X4) that receives data from the audio channel 2/R. The comparator is a zero-

crossing detector which produces a pulse for all transitions through ground. One output of the edge comparator is coupled to a data detector (S2). The detector determines whether an edge is detected between clock pulses from the output of the edge comparator. A detected edge indicates that a "1" was received by the edge comparator. When that occurs, the data detector generates a high to be clocked into a serial to parallel (K1) converter via the clock from the clock detector. Audio track 2/R of the video disc player is a 1 volt peak to peak signal which comes into J6. The audio signal is then amplified and filtered to pass audio frequencies only. The 5V PP audio frequency signal is DC restored with C79, D1, D2 and through C2 to a biasing network composed of R10 and R11 to a low pass filter made of R36 and C10 to the zero crossing detector (X4). The pulse train at the AND gate, pin 8 of S4, is high when the input wave passes through ground. This signal is sent to E3, M5 and V5 so that the clock and break in transmission signals can be formed. The data is stripped off by A4 and S2 and sent to the serial to parallel converter, K1.

The parallel data is sent to the bus transceiver (M1, N3 and N2) which detects the buffer sync byte, 67 (hex). A high pulse is produced at N2, pin 2, when the buffer sync byte is detected. This high is inverted by the NAND gate (S3) and clears the ready flag D flip flop (V4) and the RAM address counters (V3, V2 and V1) through the AND gate (S4). The RAM address counters sequentially address the RAM (S1) to store the data from the audio track for the game machine's later use. The clock for these counters came from two places, the data clock divided by 8 via N4 and the game machines address strobe shaped through B4. These clocks are multiplexed through the three NAND gates (S3) and controlled by the ready flag signal. The game machine reads the data through the Bus transceiver (K2) and strobe STB2.

COMMAND CONTROLLER

The Command Controller is the means by which the game machine sends instructions to the video disc player i.e., play, reject, still/step etc. The 555 timer produces a 38 KHz clock signal when pin 4 is high. The clock can be calibrated by moving JP14 from normal to test and adjusting R22 until the period of the signal at pin 3 is at 26us. This is the clock to the counter chain made up of X2, W1 and X1.

IX. THEORY OF OPERATION

X2 is the burst counter which strobes W2 to gate 10 clock cycles to the output. W1 is the data to period counter. If the data from M2 pin 9 is a logical high, the W1 is preset with an 8 which is approximately 2.1 ms. If the data is a logical low, W1 is preset with a 4 which is approximately a 1.05 ms period. X1 is the bit counter which counts 11-bits and sets the end of transmission flip flop (W2).

M2 is an 8-bit shift register that serializes the command byte from the game machine to the video disc player. Q1 and Q2 are output amplifiers.

DISC READY FLAG

The Color/Sync Board sends a TTL level signal to E2 on the Interface Board called the Disc Ready Flag. This signal is high when the disc player is producing valid video.

SOUND BOARD

The MA-495 Sound Board consists of two 6502 microprocessor systems, a dual DAC, an L.P.C. speech generator, two programmable sound generators, input ports to receive commands from the game Logic Board, external audio input and a low level audio output, which is sent to the MA-479 Power Supply Board for amplification.

The Sound Board requires three supply voltages: +5V DC, +12V DC and -12V DC. In addition a power up reset signal is required from the Power Supply Board.

SYSTEM CLOCK

A 4 MHz oscillator is configured with R11, R12, C14, C15, C22, XTAL-1 and T1. R21 and C22 are optional. This 4 MHz clock is divided by 4 to a 1 MHz clock for both processors' clock input, pin 37 of N1 and T3. A 2 MHz clock from S1 pin 14 is sent to the two AY-3-8913 Programmable Sound Generator, H4 and K4, pin 20. A 250 KHz signal from S1 pin 11 is the clock for the programmable timer section consisting of N5, H5, T5 and K5, pin 2.

INPUT CODE LATCH SYSTEM

Eight input lines from the Logic Board come in on P4 and are pulled up by SIPI and sent to the two input code latches A3 and B2, one for each microprocessor system. A2, pin 8, becomes a logic high when any of its inputs are low. This output is connected to pin 11 of the input code latches (A3 and B2). A positive edge at pin 11 causes A3 and B2

to latch the data at their inputs. A2 pin 8 is also connected to the clock inputs of two flip flops, A4 pin 3 and A4 pin 11. When A2 pin 8 goes high, both flip flops are clocked, setting both \bar{Q} outputs low. The \bar{Q} outputs, A4 pin 6 and pin 8, are connected to both of the 6502's active low interrupt request lines, T3 and N1, pin 4. The \bar{Q} outputs of A4 will stay low until the associated 6502 reads its input port therefore clearing the interrupt.

NOTE: DIP switch 3 should remain ON and DIP switch 4 should remain OFF for video games.

DAC PROCESSOR

The DAC processor system (module) consists of N1 (CPU), N2 (data bus driver), K2 (ROM), H2 (RAM), E2 (dual DAC), B2 (input code latch) and half of S2 (decoder). The CPU receives the interrupt from the input latch system (A3, A4) and the NMI (non-maskable interrupt) from S2, pin 10, of the AY processor.

The two jumpers, JP3 and JP4, allow for different types of RAM. For use of HM6116 or 2158A type RAM, JP3 should be connected and JP4 open. If using a 2158B RAM, the opposite applies.

The memory map is split into four 16K boundaries by S2, using address lines A14 and A15. These signals are used to select each RAM, ROM, DAC or input port device.

E2 is the Dual Digital to Analog Converter. DAC A is used for a 256 position volume control. It uses +5V DC for a reference voltage and has an op amp (B1 pins 5, 6 and 7) for current to voltage conversion. The output of DAC A at B1 pin 7 should swing between zero and -5V DC, depending on the current converted voltage from DAC A. DAC B's output at B1 pin 8 should swing between zero and +5V DC, depending on the sound being produced. This signal output is capacitively coupled by C13 and sent to the main summer.

AY PROCESSOR

The AY processor system (module) consists of T3 (CPU), S3 (data bus driver), N3 (ROM), K3 (ROM), H3 (RAM), E3, G3, N4, S5 (output ports), B3 (input port), A3 (input code latch), T4 and half of S2 (decoders). The processor, T3, receives its interrupts from its input latch system, A3 and A4, and NMI

IX. THEORY OF OPERATION

(non-maskable interrupt) from the output of the programmable timer, G4 pin 8.

Jumpers JP1 and JP2 at RAM H3, pin 19, allow for different types of RAM. When a HM6116 or 2158A RAM is used, JP1 is connected. When a 2158B is used, JP2 is connected.

The address decoder (T4) uses A13 through A15 to divide the memory map into 8K boundaries. Address lines A11 and A12 are also split into 4 by half of S2. This produces eleven active low chip enable signals.

PROGRAMMABLE SOUND GENERATOR

The Programmable Sound Generators, H4 and K4, receive data from N4 (output port) and three control lines from G3 (octal D type latch). Both Programmable Sound Generators use a 2 MHz clock on pin 14 from S1, (synchronous 4-bit counter).

The audio outputs of H4 on pins 15, 17 and 19 are pulled down by R4, R7 and R8 and are summed by R42 through R45 and an op amp H1, pins 1, 2 and 3. The output from H1 pin 1, is capacitively coupled by C23 to the main summer. The audio outputs of K4 on pins 15, 17 and 19, are pulled down by R22, R23 and R24 and summed by R29, R30, R32, R36 and H1 (op amp pins 12, 13 and 14). The output from H1 pin 14 is filtered by two 1.6 KHz low pass filters. The first filter consists of C5, R37, R38 and op amp H1, pins 8, 9 and 10. The second filter consists of C6, R40, R41 and H1 (op amp pins 5, 6 and 7). The output from the second filter is capacitively coupled by C7 to the main summer.

SPEECH

The Speech Synthesizer Chip, E4, receives data from E3 (output port) and three control lines from G3 (output port). The speech chip sends a signal data

request on E4, pin 6. The AY processor reads this request through input port B3. The speech chip contains its own 3.12 MHz clock which consists of C1, C2, R1, R2 and XTAL-2. The audio output of the speech chip on pin 19 is pulled up by R3 and is capacitively coupled by C20 to a 160 Hz low pass filter consisting of C3, R19, R26 and B1. The output at B1 pin 1 is capacitively coupled by C17 to the main summer.

PROGRAMMABLE TIMER

H5 (synchronous 4-bit counter) and K5 form a divide by 256 pre-scaler whose input is 250 KHz and output is 977 Hz. N5, T5 and S5 form a programmable divider whose output at T5 pin 15, can be from 977 Hz to 4 Hz depending upon the value at the output port, S5.

The output of timer T5 causes an NMI to the AY Processor and can be controlled by output G3 using the AND gate G5.

RESET

The Sound Board receives an external reset signal from P3 pin 1. This active low reset signal is pulled up by R34 and sent to G5, pin 1 (2-input AND gate). However, if a manual reset is desired, pushing switch SW2 will reset the processor.

INPUT PORT

Input Port B3 reads the test switch SW1 and two option switches, DIP switches 1 and 2. It also reads four extra inputs from P5 for future expansion. Pressing test switch SW1 will produce a tone.

MAIN SUMMER

The main summer consists of R13 through R17, R20 and B1, pins 12, 13 and 14. B1 pin 14 is the main output from the Sound Board, at P1 pin 2, and will swing plus or minus 5V peak to peak.

IX. THEORY OF OPERATION

SYSTEM TROUBLESHOOTING FLOW CHART

Included in the Theory of Operation section (next page), is an operators troubleshooting flow chart for logical step by step problem solving. A troubleshooting flow chart, together with the

Theory of Operation section and the Self Test Mode in the game, will help you isolate and correct almost any problems that may occur.

SERVICE NOTES

The transition to video disc game maintenance and troubleshooting will require a new type of maintenance performed regularly. Mylstar Electronics and Pioneer Video, Inc. recommend a once a month schedule of preventative maintenance (PM) consisting of three main steps. Following these procedures on a regular basis will help to assure an efficiently operating game with a minimum of down time.

PM—PREVENTATIVE MAINTENANCE STEPS:

- I. Clean the air filter
- II. Clean the disc
- III. Clean the objective lens

RECOMMENDED SCHEDULE:

A minimum of once a month.

PROCEDURES:

- I. Clean the air filter — (Procedures for locating and removing the air filter are detailed on Pages 4 and 5).

Clean the air filter in warm soapy water.

Allow the filter to dry and then replace in game.

To access the disc and objective lens for cleaning open the back door of the game with power on. Press the "Reject" button on the front control panel of the Laser Disc Player. The red "Stand-By" LED indicator will begin flashing. When the "Stand-By" indicator stops flashing, press the reject button

again. Turn power to the game off during the cleaning procedures.

II. Clean the disc

1. Clean the disc with warm soapy water or an ammonia based glass cleaner. Use a soft non-abrasive lint free cloth.
2. Do not use alcohol based or high strength ammonia based cleaners as this may damage the plastic coating on the disc.
3. Discs may need to be cleaned more frequently if the game is in a dusty or humid area.

III. Clean the objective lens

1. Never use "Q-Tips," regular lens cleaning paper, or glasses tissue to clean objective lens.
2. Use liquid Freon or Trichlorotrifluoroethane solvent to clean lens (i.e. "Freon TF" solvent).
3. Pioneer GED-008 Lens Paper is recommended for cleaning the lens. Using a pair of rounded tweezers (never sharp edges) fold a lens paper in half around the tweezers, leaving 1/2" protruding past the end of the tweezers wrap all of the paper around the tweezers. Spray the lens with the TF Solvent and clean immediately with the lens paper. Use the lens paper only once and discard. The Pioneer GED-008 Lens Paper is available at your Mylstar authorized distributor.

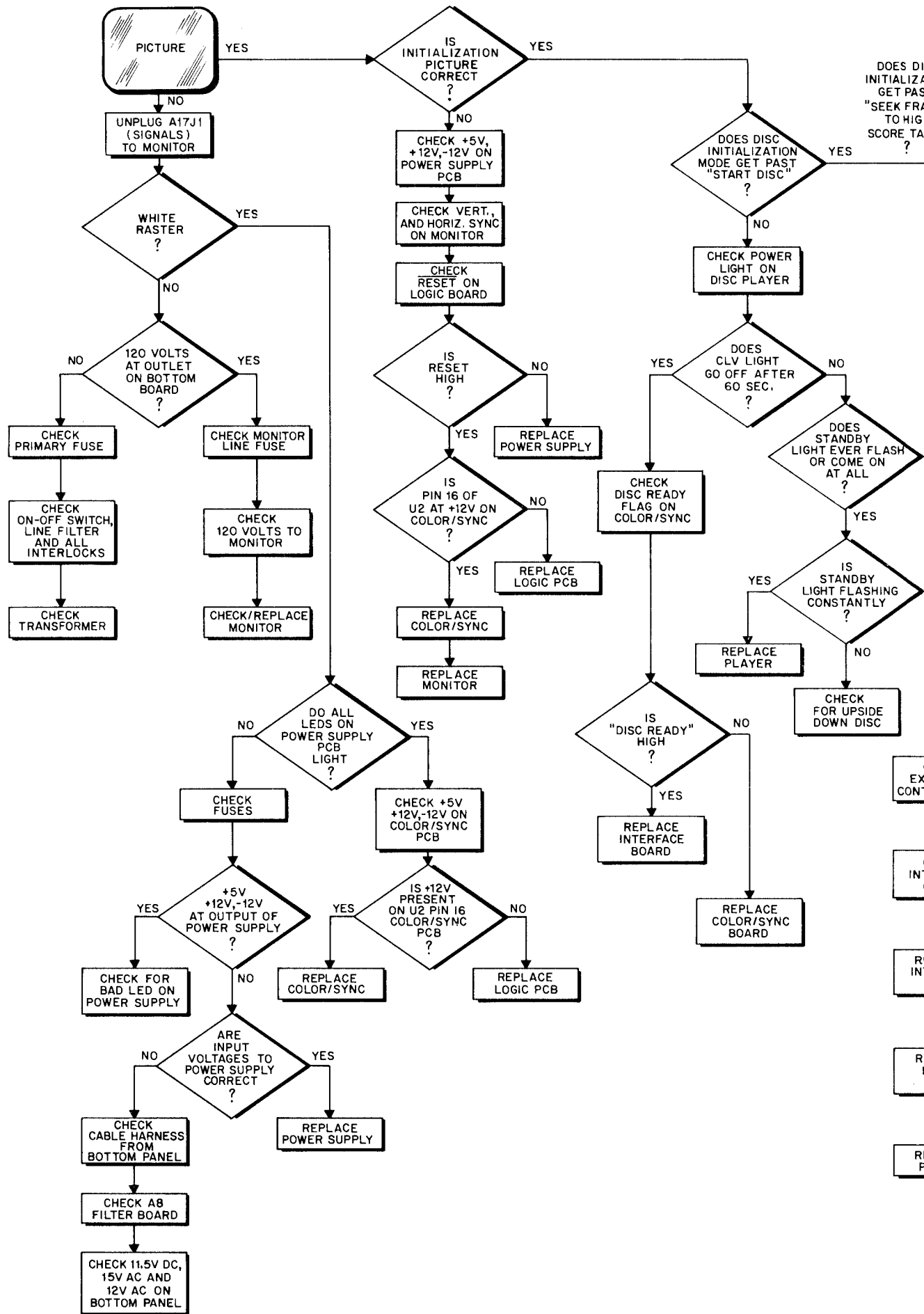

THEORY OF OPERATION

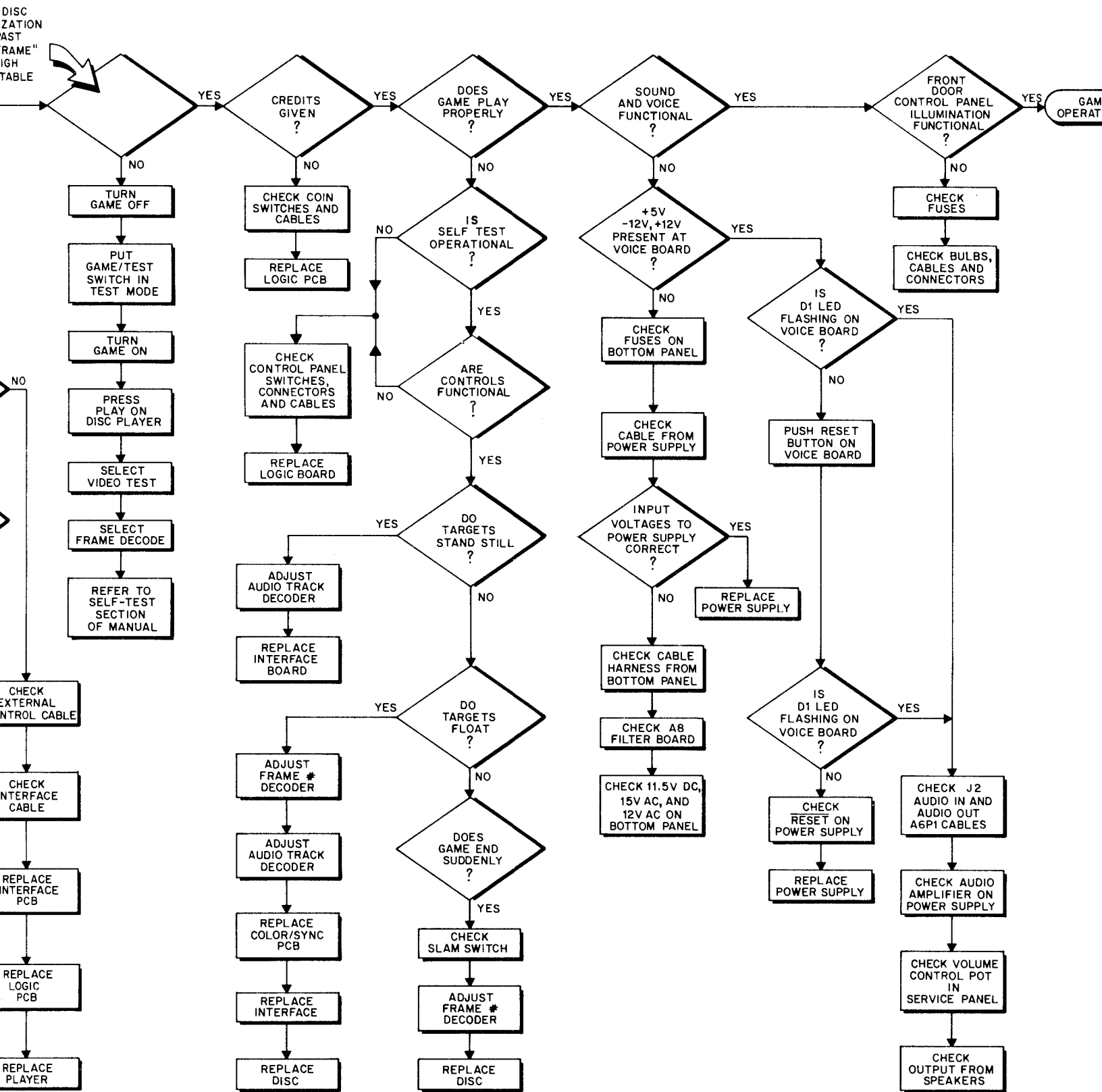

TROUBLESHOOTING FLOW CHART

X. WIRING AND SCHEMATIC DIAGRAMS, PARTS LISTS



TABLE OF CONTENTS

	PAGE
LOGIC BOARD ASSY. (A1)	
COMPONENT LOCATION AND PARTS LIST	26, 29
SCHEMATIC DIAGRAM (SHEET 1 OF 3)	30
SCHEMATIC DIAGRAM (SHEET 2 OF 3)	32
SCHEMATIC DIAGRAM (SHEET 3 OF 3)	35
INTERFACE BOARD ASSY. (A2)	
COMPONENT LOCATION AND PARTS LIST	38
SCHEMATIC DIAGRAM	39
COLOR/SYNC BOARD ASSY. (A18)	
COMPONENT LOCATION AND PARTS LIST	41
SCHEMATIC DIAGRAM	42
SOUND BOARD ASSY. (A6)	
COMPONENT LOCATION AND PARTS LIST	44
SCHEMATIC DIAGRAM	45
POWER SUPPLY ASSY. (A3)	
COMPONENT LOCATION AND PARTS LIST	47
SCHEMATIC DIAGRAM	48
PRIMARY POWER/FILTER BOARDS/ INTERCONNECTION DIAGRAM	50

X. WIRING AND SCHEMATIC DIAGRAMS, PARTS LISTS

LOGIC BOARD ASSY. (A1), PARTS LIST

INTEGRATED CIRCUITS

REFERENCE	DESCRIPTION	PART NO.	REFERENCE	DESCRIPTION	PART NO.
	Logic Board Assy.	MA-498	M7	74157 Quad 2-input multiplexer	XO-114
A1	8284 CLK Driver	XO-478	M8	74LS74 Dual D-type flip flop	XO-434
A2	74LS02 Quad 2-input "NOR" gate	XO-428	M9	74S157 Quad 2-input multiplexer	XO-124
A3	74161 Synchronous 4-bit counter	XO-192	M10	74LS245 Octal bus transceiver	XO-79
A7	74LS02 Quad 2-input "NOR" gate	XO-428	M11	74LS374 Octal D-type flip flop	XO-96
A8, A9, A10	74LS273 8-bit register	XO-94	M12	74LS157 Quad 2-input multiplexer	XO-390
B1	8088 CPU	XO-490	M13, M14, M15	7489 64-bit RAM	XO-88
B3	74LS373 Octal D-type flip flop	XO-445	M16, M17	74LS174 Hex D-type flip flop	XO-442
B4	74LS367 Hex 3-state buffer	XO-444	N1, N2, N3,	74S189 64-bit RAM	XO-89
B5	74LS08 Quad 2-input "AND" gate	XO-86	N4		
B6	74HC138 1 of 8 decoder	XO-190	N5, N6	74S161 Synchronous presettable binary counter	XO-488
B7	74LS139 Dual 1 of 4 decoder	XO-419	N7, N8, N9,	74LS157 Quad 2-input multiplexer	XO-390
B8	74S138 1 of 8 Decoder	XO-113	N10		
B9, B10	74LS138 1 of 8 decoder	XO-437	N11	74LS260 Dual 5-input "NOR" gate	XO-93
B11, B12, B14	74LS240 Octal buffer/line driver	XO-91	N12	74LS298 Quad 2-port register	XO-118
E3	74LS373 Octal D-type flip flop	XO-445	N13	74LS157 Quad 2-input multiplexer	XO-390
E4	74LS245 Octal bus transceiver	XO-79	N14	74LS00 Quad 2-input "NAND" gate	XO-427
E5 RAM0	HM6116LP-4 2K x 8 SRAM	XO-191	N15	74LS30 8-input "NAND" gate	XO-432
E6 RAM1	HM6166LP-4 2K x 8 SRAM	XO-191	N16, N17	74LS86 Quad 2-input "Exclusive-OR" gate	XO-435
E7 RAM2	HM6116P-4 2K x 8 SRAM	XO-195	S1, S2, S3,	74L189 64-bit RAM	XO-89
E8 RAM3	HM6116P-4 2K x 8 SRAM	XO-195	S4, S5, S6		
E11 ROM0	2764-3 8K x 8 EPROM	XO-489	S7	74LS04 Hex inverter	XO-418
E13 ROM1	2764-3 8K x 8 EPROM	XO-489	S8	74LS32 Quad 2-input "OR" gate	XO-433
E14 ROM2	2764-3 8K x 8 EPROM	XO-489	S9	7408 Quad 2-input "AND" gate	XO-404
G1	74LS139 Dual 1 of 4 decoder	XO-419	S10, S11	93422 256 x 4 Bipolar RAM	XO-100
G2, G3, G4	74157 Quad 2-input multiplexer	XO-114	S12	74LS02 Quad 2-input "NOR" gate	XO-428
G5, G6, G7			S13	74LS74 Dual D-type flip flop	XO-434
G8, G9, G10			S14	7407 Hex buffer/driver	XO-384
G11	74LS374 Octal D-type flip flop	XO-96	S15	74LS30 8-input "NAND" gate	XO-432
G12	74LS244 Octal buffer/line driver	XO-117	S16, S17	74S161 Synchronous presettable binary counter	XO-488
G13	74LS157 Quad 2-input multiplexer	XO-390	T1, T2, T3	74LS379 Quad D-type flip flop	XO-98
G15	74LS86 Quad 2-input "Exclusive-OR" gate	XO-435	T4 FGO	27128, 128K EPROM	XO-831
G16	74LS283 4-bit binary full adder	XO-95	T5 FGI	27128, 128K EPROM	XO-831
G17	74S161 Synchronous presettable binary counter	XO-488	T6 FG2	27128, 128K EPROM	XO-831
H1, H2, H4	93419 64 x 9 bipolar RAM	XO-99	T8 FG3	27128, 128K EPROM	XO-831
H5	74LS283 4-bit binary full adder	XO-95	T9, T10, T11	74LS157 Quad 2-input multiplexer	XO-390
H6	74LS30 8-input "NAND" gate	XO-432	T12	74LS260 Dual 5-input "NOR" gate	XO-93
H7	4801AN-3 1K x 8 RAM	XO-193	T13	74LS32 Quad 2-input "OR" gate	XO-433
H8, H9	74LS245 Octal bus transceiver	XO-79	T14	74LS08 Quad 2-input "AND" gate	XO-86
H10	4801AN-3 1K x 8 RAM	XO-193	T15	74LS04 Hex inverter	XO-418
H12 BGO	2732A 4K x 8 EPROM	XO-485	T16	74LS20 Dual 4-input "NAND" gate	XO-430
H13 BGI	2732A 4K x 8 EPROM	XO-485	T17	74S161 Synchronous presettable binary counter	XO-488
H15	74LS86 Quad 2-input "Exclusive-OR" gate	XO-435	V4, V5, V6,	74LS166 8-bit shift register	XO-391
H16	74LS273 8-bit register	XO-94	V7		
H17	74LS20 Dual 4-input "NAND" gate	XO-430	V9, V10	74LS74 Dual D-type flip flop	XO-434
K5	74LS283 4-bit binary full adder	XO-95	V11	74LS20 Dual 4-input "NAND" gate	XO-430
K6	74LS32 Quad 2-input "OR" gate	XO-433	V12	74S161 Synchronous presettable binary counter	XO-488
K15	74LS04 Hex inverter	XO-418	V14	74S74 Dual D-type flip flop (T.I. only)	XO-87
K16	74S161 Synchronous presettable binary counter	XO-488	V15	74S157 Quad 2-input multiplexer	XO-124
K17	74LS86 Quad 2-input "Exclusive-OR" gate	XO-435	V16	74S04 Hex inverter	XO-400
M1, M2, M3	74LS157 Quad 2-input multiplexer	XO-390			
M4, M5					
M6	74LS161 Synchronous presettable binary counter	XO-440			

X. WIRING AND SCHEMATIC DIAG LOGIC BOARD ASSY. (A1), COMPO

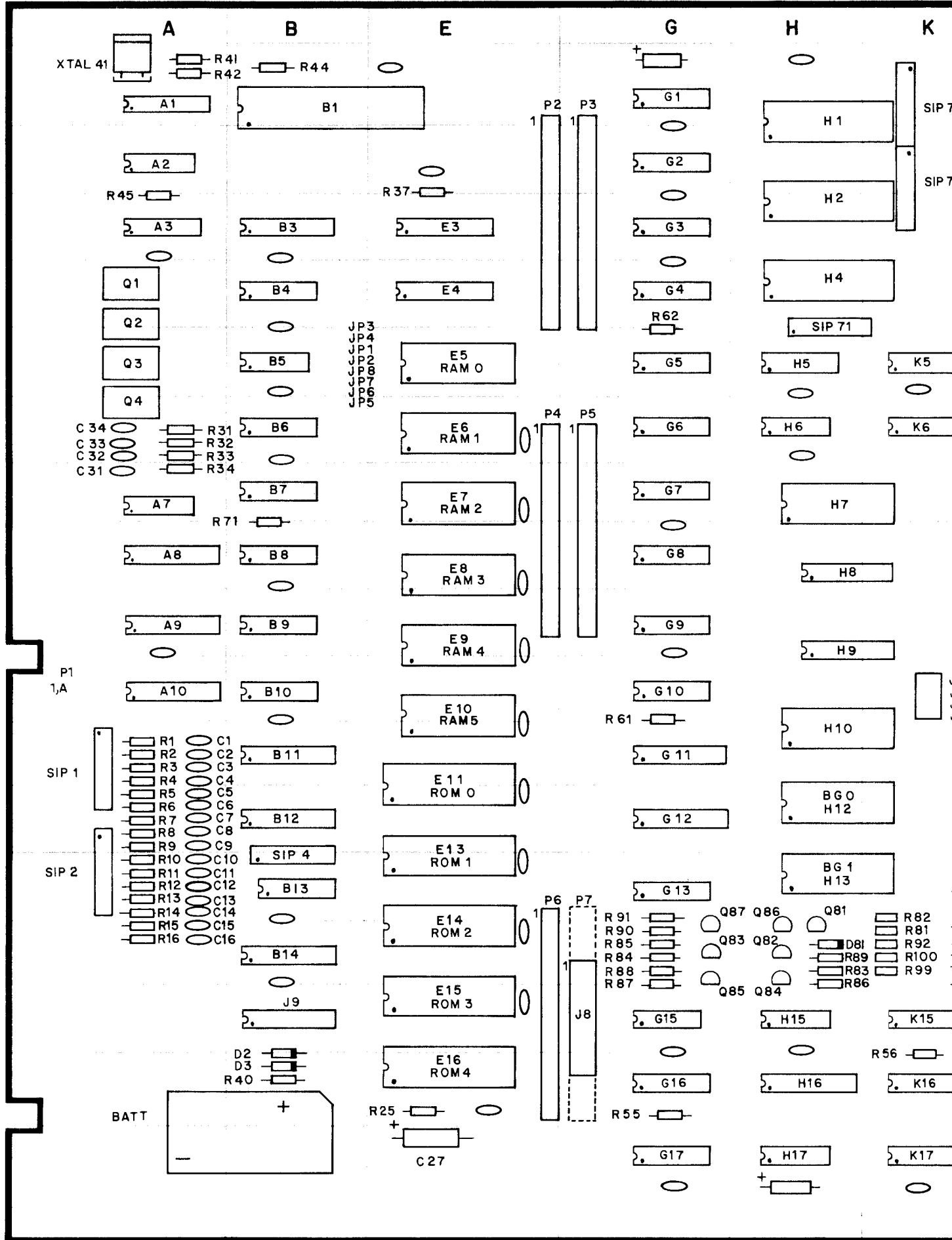

DIAGRAMS, PARTS LISTS

COMPONENT LOCATION

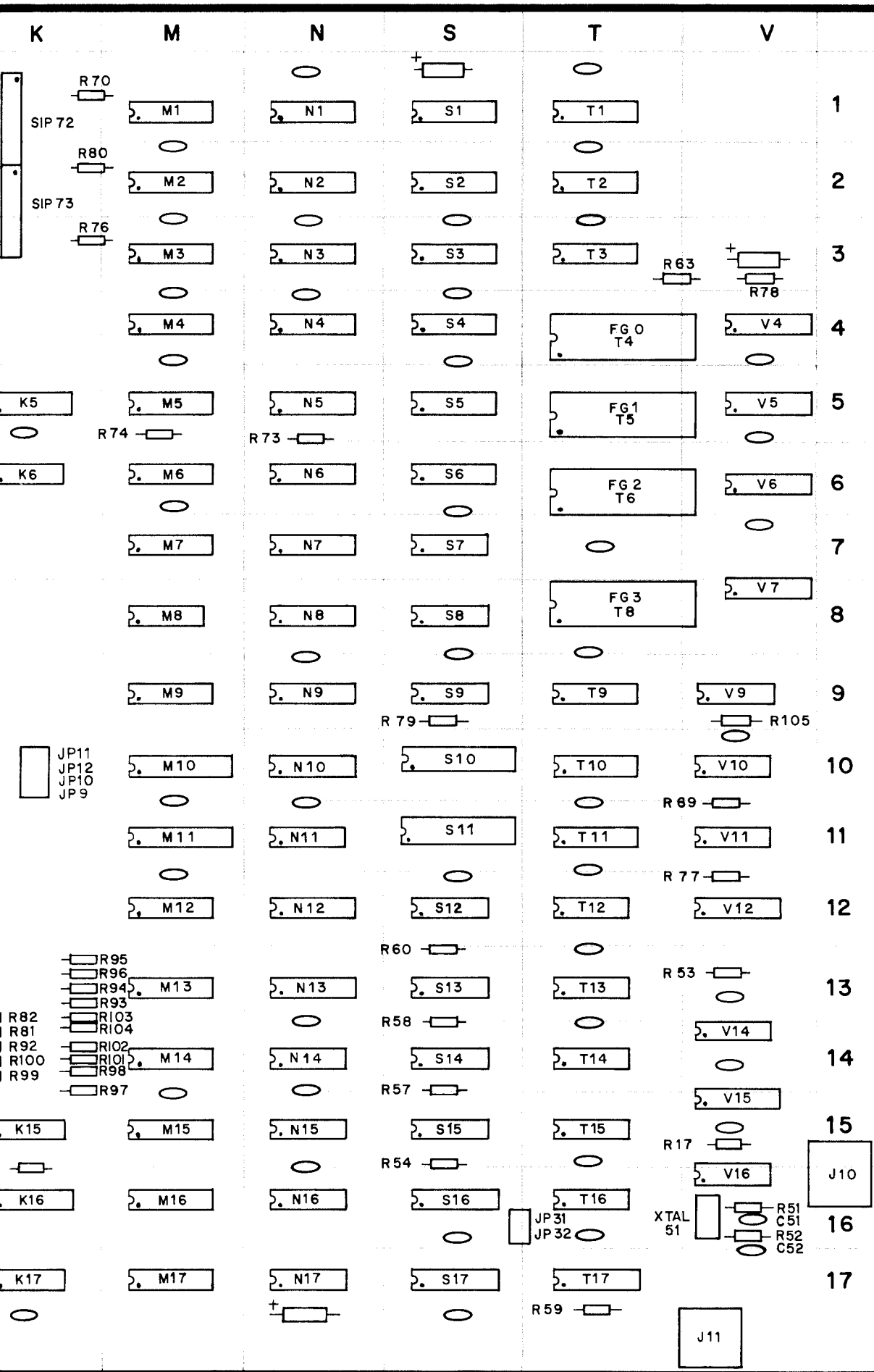

X. WIRING AND SCHEMATIC DIAGRAMS, PARTS LISTS

LOGIC BOARD ASSY. (A1), PARTS LIST (CONT.)

MISCELLANEOUS ELECTRONIC COMPONENTS

REFERENCE	DESCRIPTION	PART NO.
BATT.	Battery, 3.6V	XO-458
B13	Dip Switch	XO-505
C1-C16	Capacitor, 0.1UF, 50V AX. CR. +80%-20%	XO-230
C27	Capacitor, 100UF, 25V EL-AX	XO-212
C31-C34	Capacitor, 0.1UF, 50V AX. CR. +80%-20%	XO-230
C51	Capacitor, 100PF, 100V CMD, 5%	XO-198
C52	Capacitor, 0.1UF, 100V CMD, 5%	XO-196
ALL UNMARKED CAPACITORS	.01UF, 50V AX. CR. +80%-20%	XO-229
ALL UNMARKED POLARIZED CAPACITORS	10UF, 25V AX. TANT 10%	XO-127
D2, D3	Diode, 1N4454	XO-275
D81	Diode, 1N4148	XO-261
J8	Header Conn., 26 Pin	XO-712
J10, J11	Phono Jack, Right Angle	XO-618
JP9-JP12	Header Conn., 2 Pin Stick	XO-123
JP31, JP32	Header Conn., 2 Pin Stick	XO-123
	Tinplate Jumper, Blue Plastic Cover	XO-122
Q1-Q4	Transistor, 2N6044	XO-120
Q81-Q87	Transistor, MPS-A70	XO-309
R1-R17	Resistor, 470 OHM, 5% 1/4W	X-35
R-25	Resistor, 1K OHM, 5% 1/4W	XO-5
R31-R34	Resistor, 1K OHM, 5% 1/4W	XO-5
R37	Resistor, 330 OHM, 5% 1/4W	XO-34
R40	Resistor, 270 OHM, 5% 1/4W	XO-68
R41, R42	Resistor, 510 OHM, 5% 1/4W	XO-25
R44, R45	Resistor, 1K OHM, 5% 1/4W	XO-5
R51, R52	Resistor, 330 OHM, 5% 1/4W	XO-34
R53, R56	Resistor, 1K OHM, 5% 1/4W	XO-5
R57, R58	Resistor, 560 OHM, 5% 1/4W	XO-36
R59-R63	Resistor, 1K OHM, 5% 1/4W	XO-5
R69-R71	Resistor, 1K OHM, 5% 1/4W	XO-5
R73, R74	Resistor, 1K OHM, 5% 1/4W	XO-5
R76-R80	Resistor, 1K OHM, 5% 1/4W	XO-5
R81	Resistor, 820 OHM, 5% 1/4W	XO-174
R82	Resistor, 100 OHM, 5% 1/4W	XO-28
R83, R84	Resistor, 15 OHM, 5% 1/4W	XO-171
R85	Resistor, 180 OHM, 5% 1/4W	XO-24
R86, R87	Resistor, 15 OHM, 5% 1/4W	XO-171
R88	Resistor, 180 OHM, 5% 1/4W	XO-24
R89, R90	Resistor, 15 OHM, 5% 1/4W	XO-171
R91	Resistor, 180 OHM, 5% 1/4W	XO-24
R92	Resistor, 1K OHM, 5% 1/4W	XO-5
R93	Resistor, 2K OHM, 5% 1/4W	XO-14
R94	Resistor, 1K OHM, 5% 1/4W	XO-5
R95	Resistor, 470 OHM, 5% 1/4W	XO-35
R96	Resistor, 240 OHM, 5% 1/4W	XO-173
R97	Resistor, 2K OHM, 5% 1/4W	XO-14
R98	Resistor, 1K OHM, 5% 1/4W	XO-5
R99	Resistor, 470 OHM, 5% 1/4W	XO-35
R100	Resistor, 240 OHM, 5% 1/4W	XO-173
R101	Resistor, 2K OHM, 5% 1/4W	XO-14
R102	Resistor, 1K OHM, 5% 1/4W	XO-5
R103	Resistor, 470 OHM, 5% 1/4W	XO-35
R104	Resistor, 240 OHM, 5% 1/4W	XO-173
R105	Resistor, 1K OHM, 5% 1/4W	XO-5
SIP1, SIP2,	Resistor Pack, Sip,	XO-492
SIP4	4.7K OHM, 9 Pin	
SIP71, SIP72,	Resistor Pack, Sip,	XO-493
SIP73	1K OHM, 9 Pin	
XTAL-41	Crystal, 15 MHZ	XO-482
XTAL-51	Crystal, 20 MHZ	XO-494
	20 Pin Dip Socket	XO-491
	22 Pin Dip Socket	XO-467
	24 Pin Dip Socket	XO-529
	28 Pin Dip Socket	XO-536
	40 Pin Dip Socket	XO-530

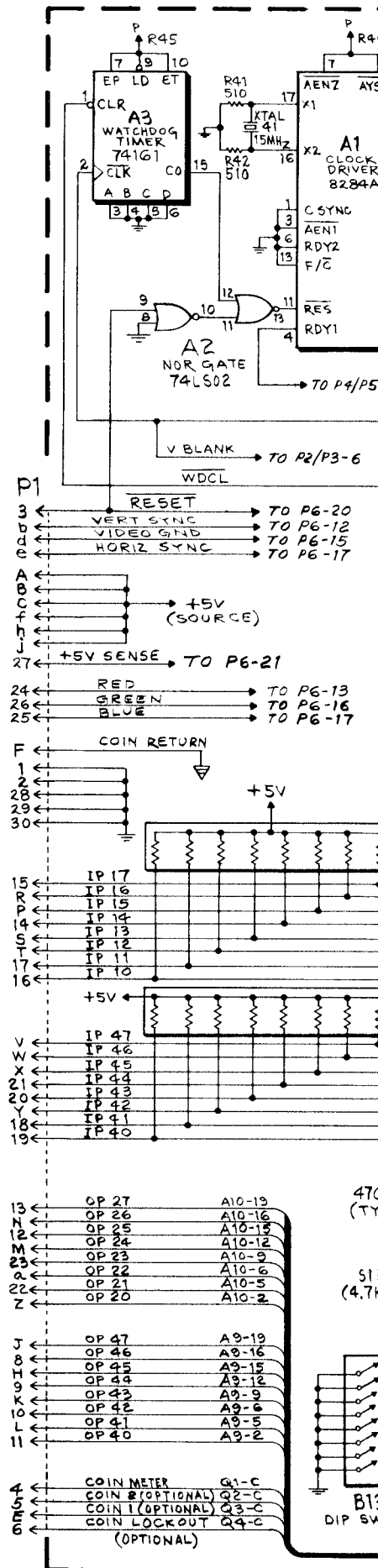

X. WIRING AND SCHEMATIC D

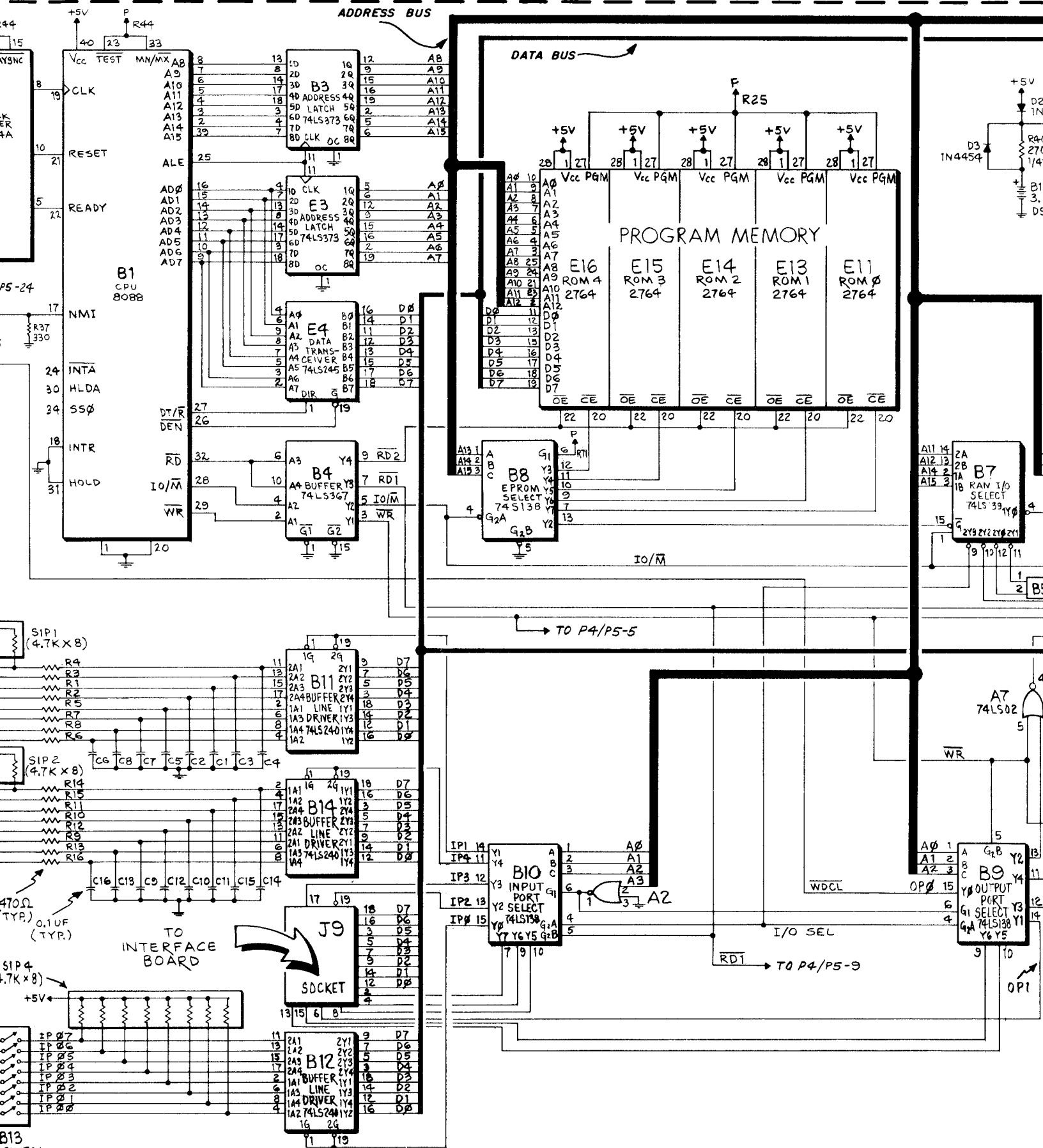

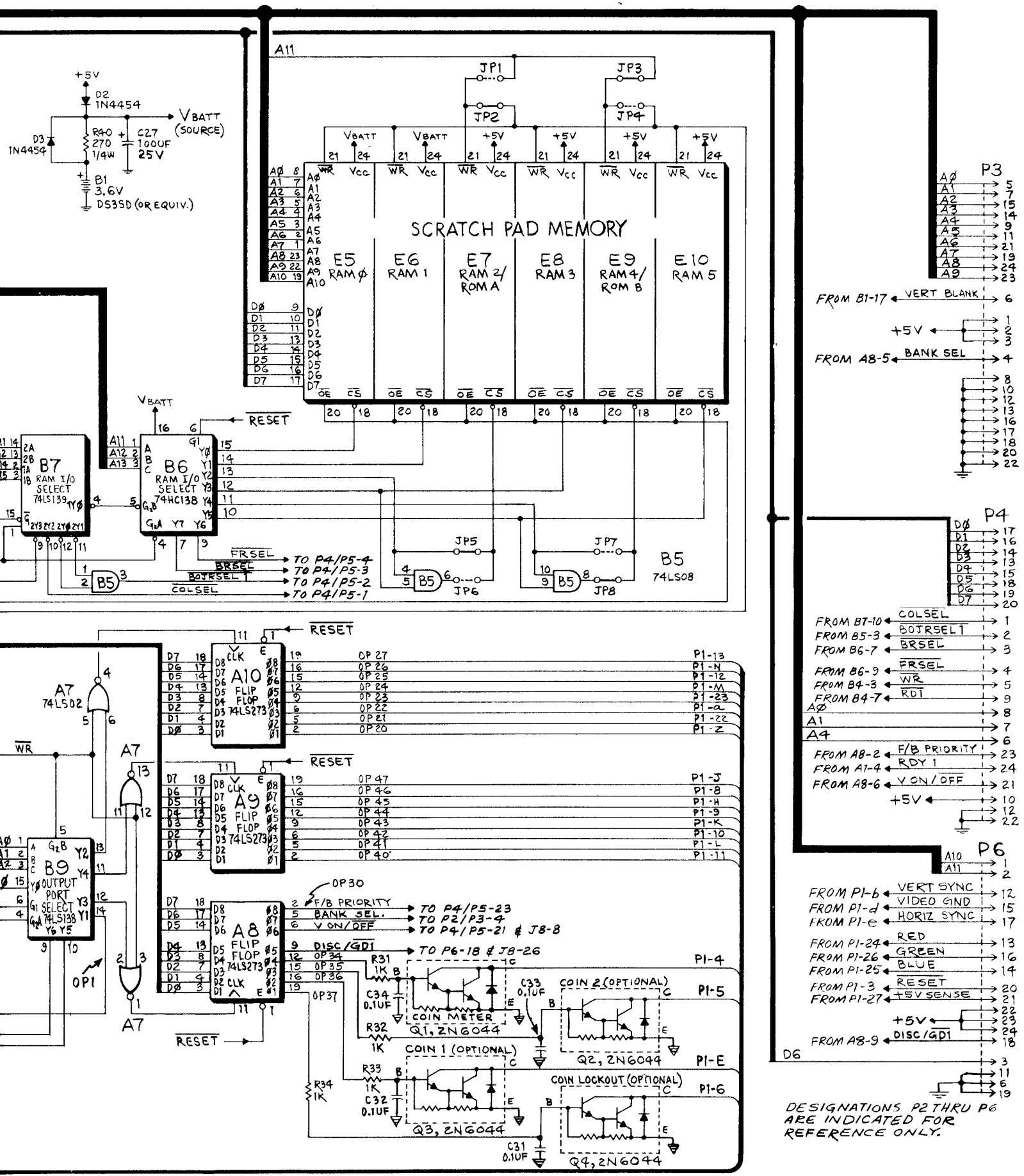

LOGIC BOARD ASSY. (A1), SCHEMATIC DIAGRAM, SHEET 1 OF 3

ADDRESS BUS
DATA BUS

P4
A0
A1
A2
A3
A4
A5
A6
A7
A8
A9

VERT BLANK
+5V
BANK SEL

P5
D0
D1
D2
D3
D4
D5
D6
D7

COLSEL
BOJRSSEL
BRSEL
FRSEL
WR
RDI
A0
A1
A4
F/B PRIORITY
RDY 1
VON/OFF
+5V

P6
A10
A11
VERT SYNC
VIDEO GND
HORIZ SYNC
RED
GREEN
BLUE
RESET
+5V SENSE
+5V
DISC/GDI

DESIGNATIONS P2 THRU P6 ARE INDICATED FOR REFERENCE ONLY.

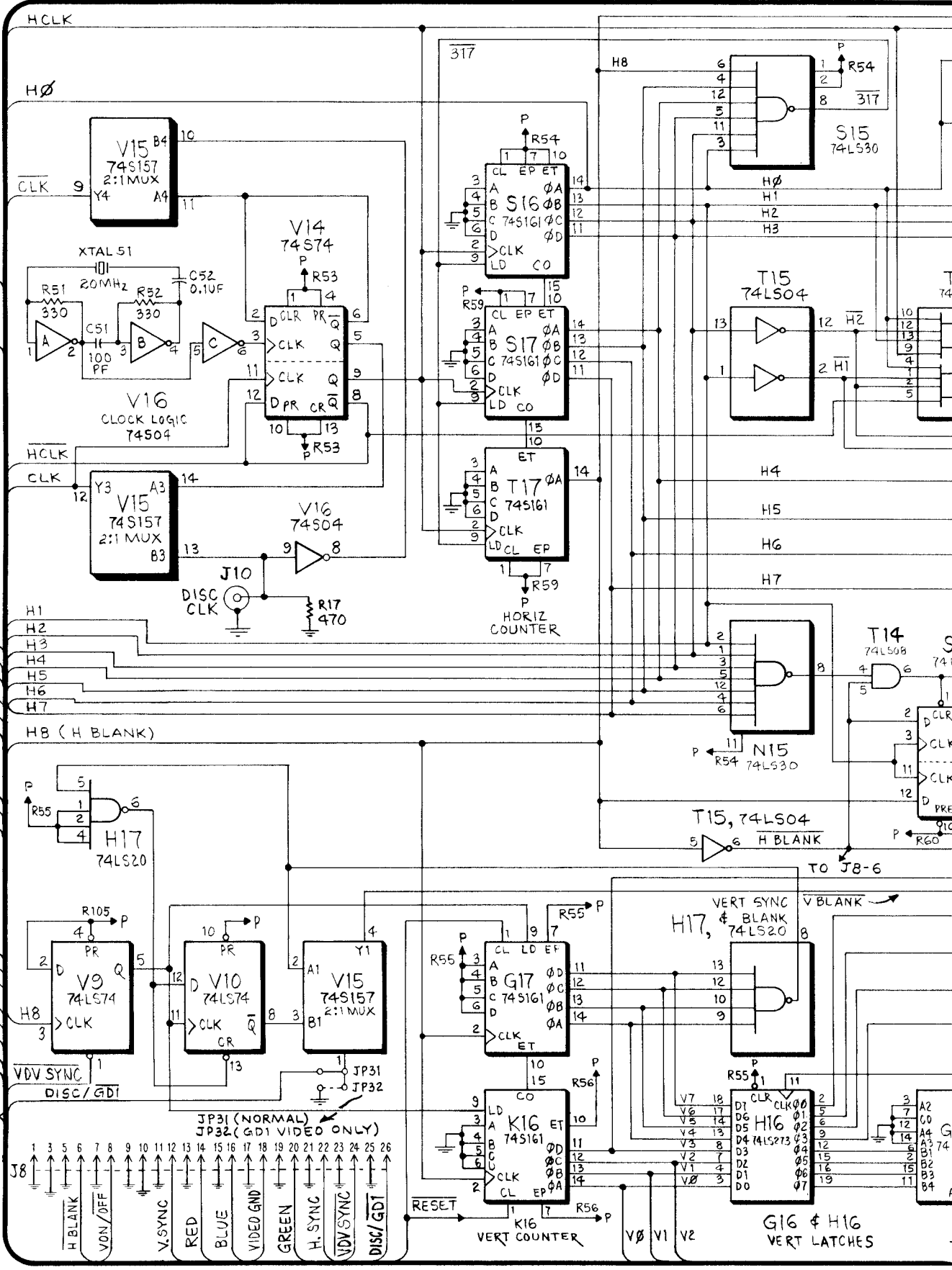

A
D
1
2
3
4
5
6
7

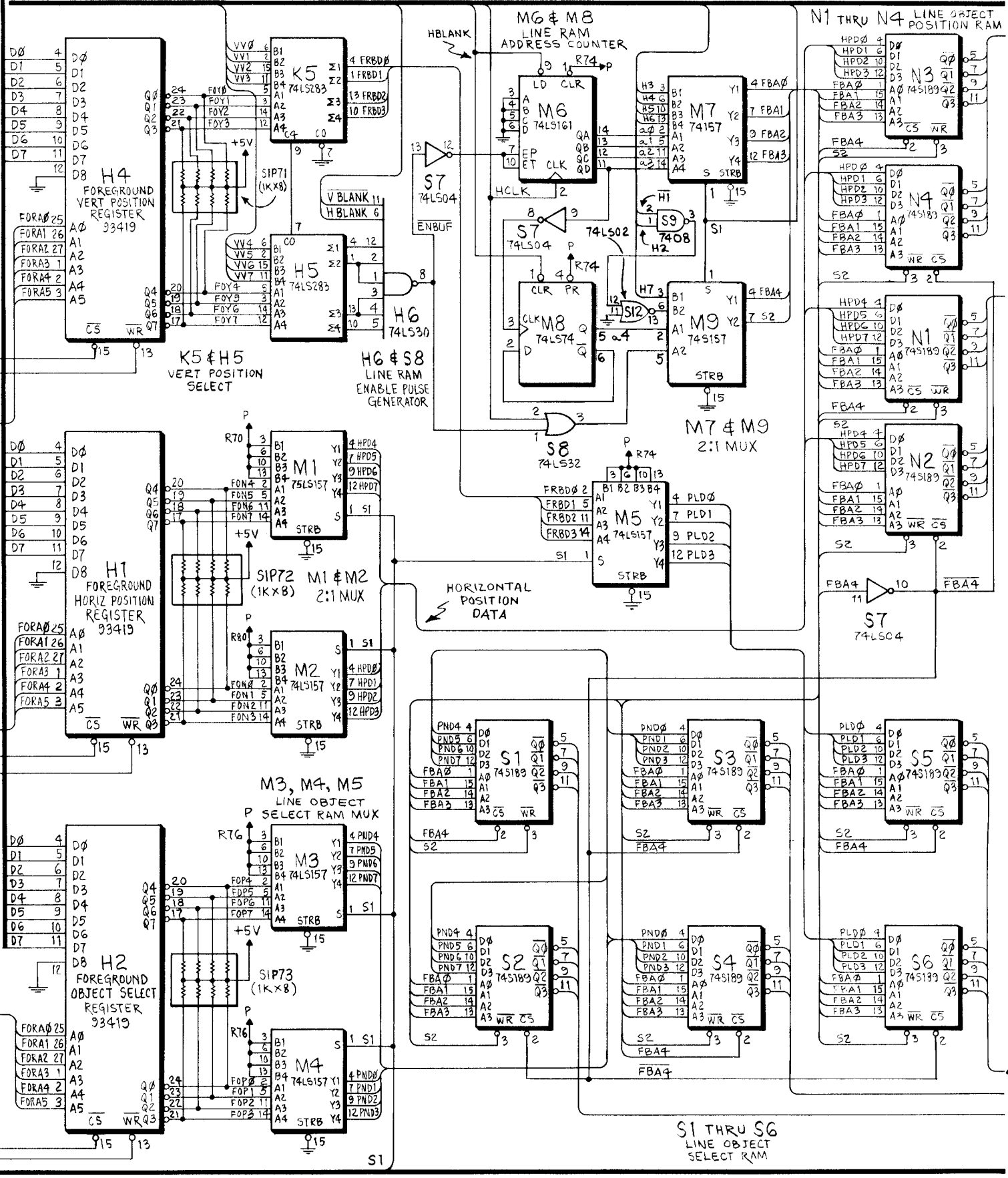

LOGIC BOARD ASSY. (A1), SCHEMATIC DIAGRAM, SHEET 2 OF 3

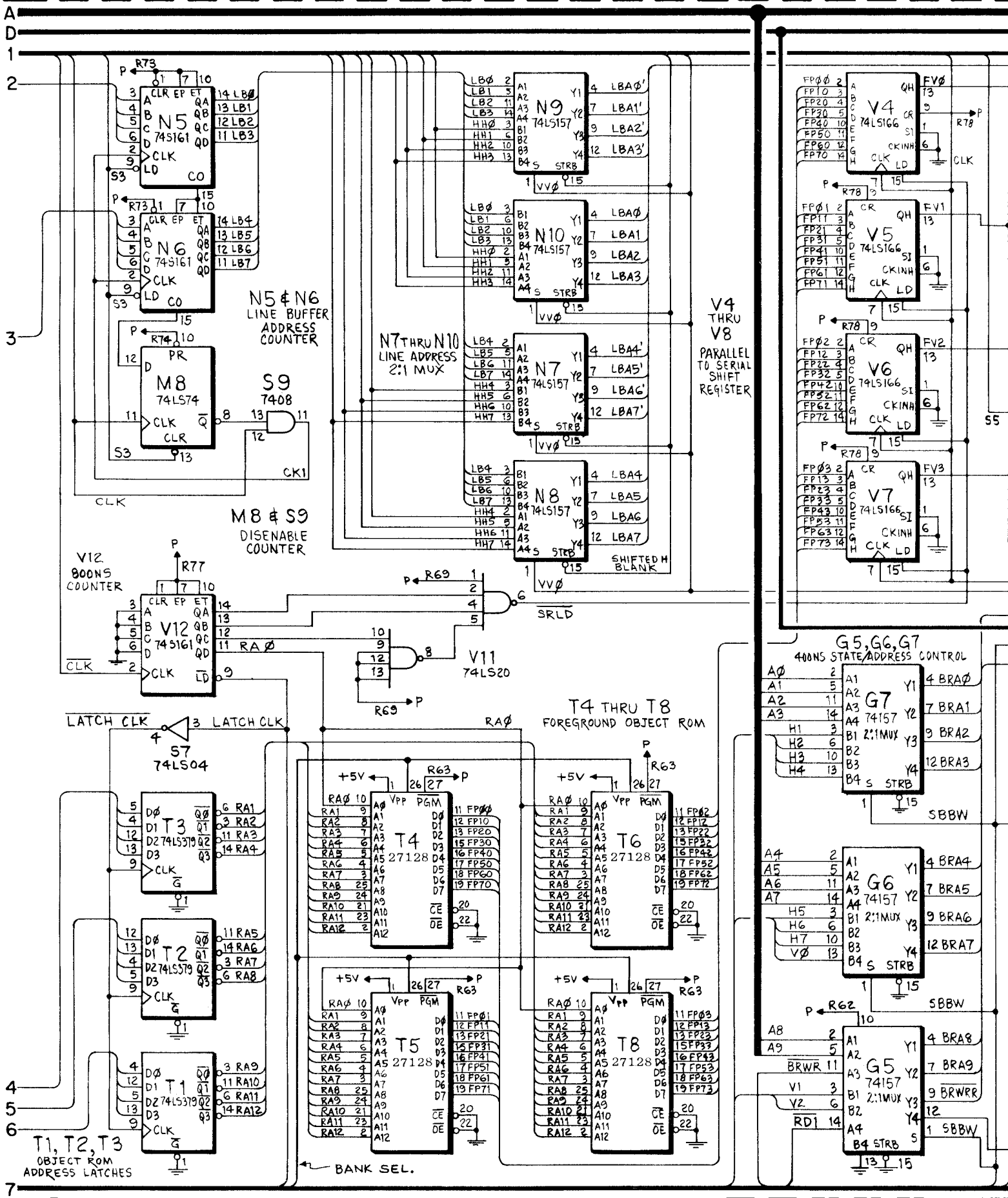

X. WIRING AND SCHEMATIC DIAGRAMS, PARTS LISTS

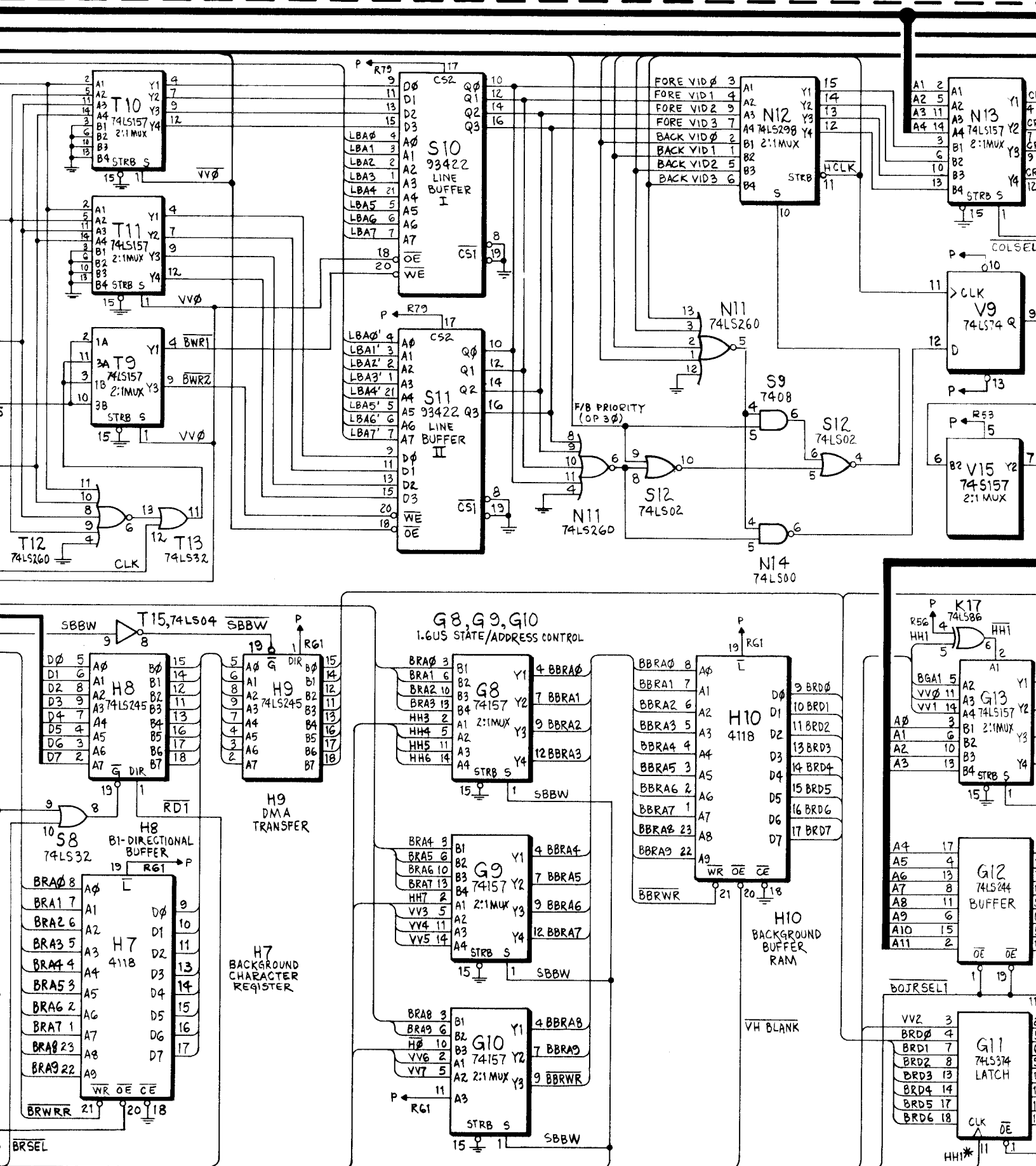

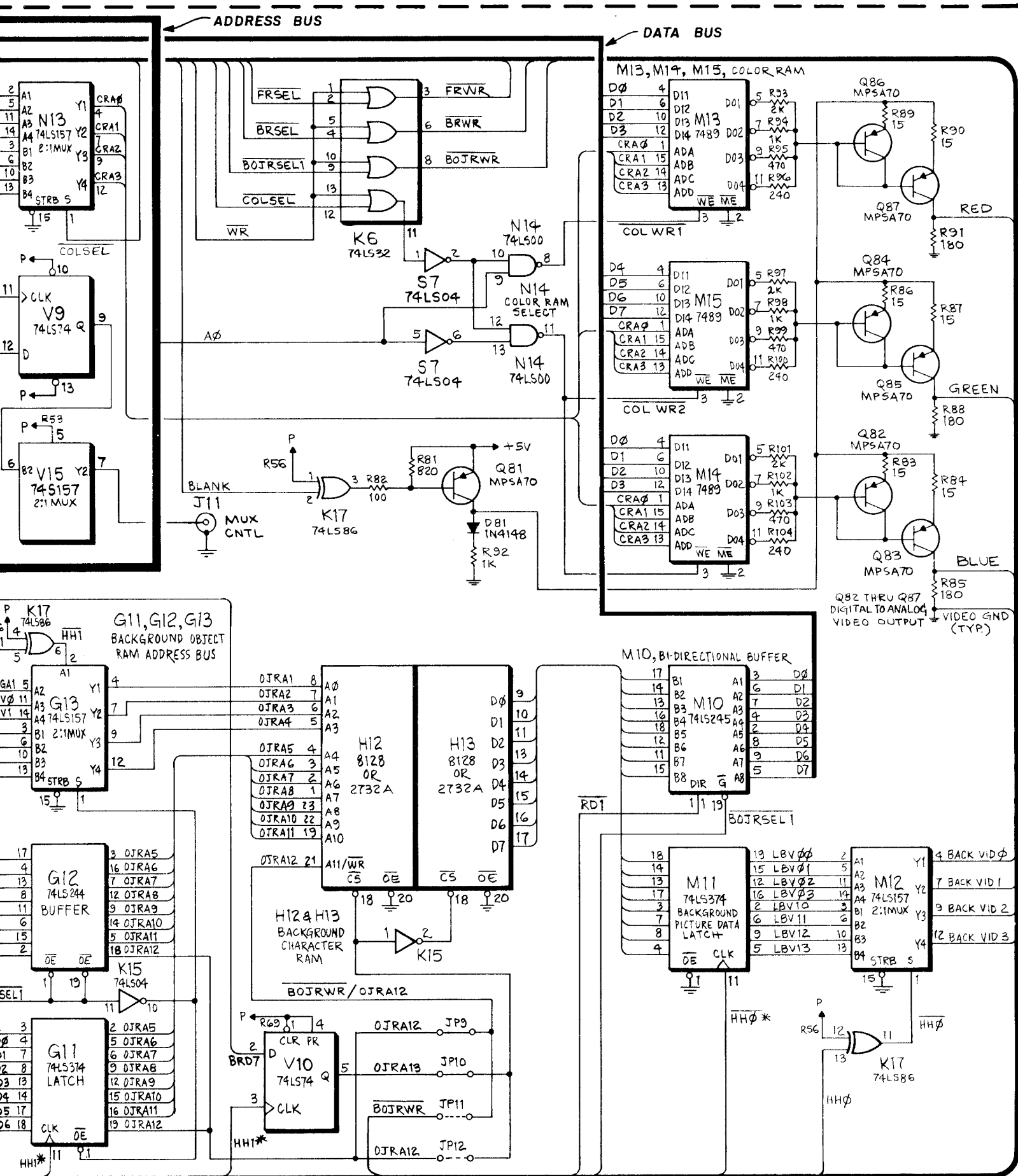

LOGIC BOARD ASSY. (A1), SCHEMATIC DIAGRAM, SHEET 3 OF 3

X. WIRING AND SCHEMATIC DIAGRAMS, PARTS LISTS

INTERFACE BOARD ASSY. (A2), COMPONENT LOCATION

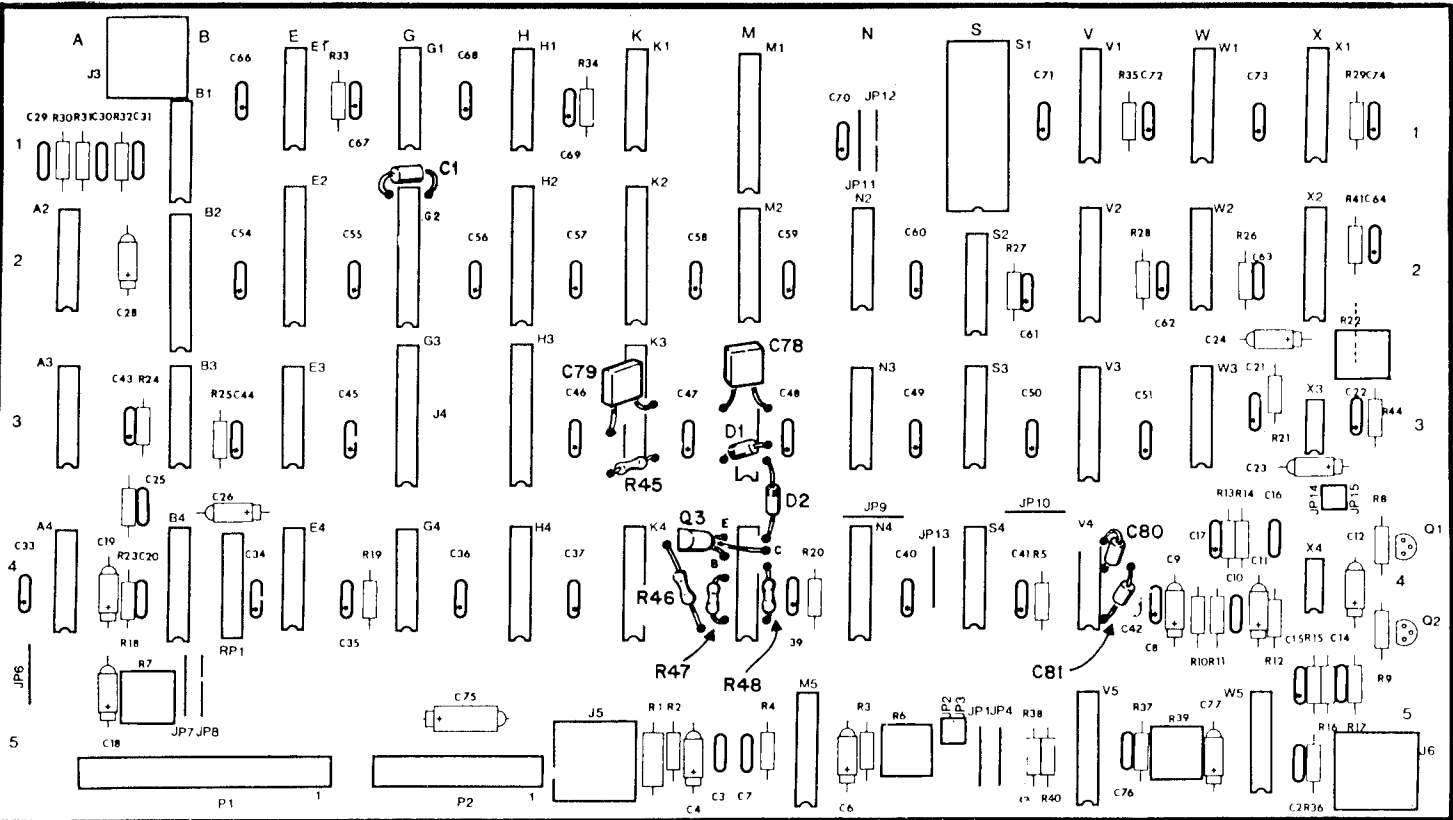

INTERFACE BOARD ASSY. (A2), PARTS LIST

REFERENCE	DESCRIPTION	PART NO.	REFERENCE	DESCRIPTION	PART NO.
	Interface Board Assy.	MA-499	R17	Resistor, 2.2K OHM, 5% 1/4W	XO-27
C2	Capacitor, 0.1UF, 50V CM-AX	XO-230	R18	Resistor, 56K OHM, 5% 1/4W	XO-771
C3	Capacitor, 0.01UF, 50V CM-AX, 10%	XO-269	R20	Resistor, 2.2K OHM, 5% 1/4W	XO-27
C4, C6	Capacitor, 10UF, 10V TANT-AX, 10%	XO-209	R21	Resistor, 16K OHM, 5% 1/4W	XO-698
C7	Capacitor, .001UF, 50V NPO CM-AX, 10%	XO-757	R22	Potentiometer, 10K OHM, 10% 1/4W	XO-690
C8	Capacitor, .01UF, 50V CM-AX, +80%-20%	XO-229	R23	Resistor, 6.2K OHM, 5% 1/4W	XO-699
C9	Capacitor, 10UF, 10V TANT-AX, 10%	XO-209	R24-R29	Resistor, 2.2K OHM, 5% 1/4W	XO-27
C1, C10, C13, C80	Capacitor, .001UF, 50V CM-AX, +80%-20%	XO-695	R30, R31, R32	Resistor, 220 OHM, 5% 1/4W	XO-21
C11, C12	Capacitor, 10UF, 10V TANT-AX, 10%	XO-209	R33, R34, R35	Resistor, 2.2K OHM, 5% 1/4W	XO-27
C14	Capacitor, 22PF, 50V MONO CM-AX, 10%	XO-633	R36	Resistor, 8.2K OHM, 5% 1/4W	XO-589
C15	Capacitor, .01UF, 50V CM-AX, +80%-20%	XO-229	R37	Resistor, 180K OHM, 5% 1/4W	XO-672
C16	Capacitor, 22PF, 50V MONO CM-AX, 10%	XO-633	R38	Resistor, 18K OHM, 5% 1/4W	XO-590
C17	Capacitor, .01UF, 50V CM-AX, +80%-20%	XO-229	R39	Potentiometer, 50K OHM, 10% 1/4W	XO-675
C18, C19	Capacitor, 10UF, 10V TANT-AX, 10%	XO-209	R40, R44	Resistor, 2.2K OHM, 5% 1/4W	XO-27
C20	Capacitor, 39PF, 50V CM-AX, 10%	XO-334	R46	Resistor, 3.9K OHM, 5% 1/4W	XO-529
C21	Capacitor, .01UF, 50V CM-AX, +80%-20%	XO-229	R47, R48	Resistor, 1K OHM, 5% 1/4W	XO-39
C22	Capacitor, .001UF, 50V NPO CM-AX, 10%	XO-757	A2	7414 Schmitt Trigger hex inverter	XO-397
C23, C24	Capacitor, 10UF, 10V TANT-AX, 10%	XO-209	A3	74LS04 Hex inverter	XO-418
C25	Capacitor, 220PF, 50V CM-AX, +80%-20%	XO-694	A4	74LS00 Quad 2-input "NAND" gate	XO-427
C26, C28	Capacitor, 10UF, 10V TANT-AX, 10%	XO-209	B1	74LS164 8-bit SIPO shift register	XO-441
C29, C30	Capacitor, 390PF, 50V CM-AX, 10%	XO-684	B2	74LS374 Octal D-type flip flop	XO-96
C31	Capacitor, 820PF, 50V CM-AX, +80%-20%	XO-692	B3	74LS74 Dual D-type flip flop	XO-434
C75	Capacitor, 100UF, 25V EL-AX	XO-212	B4	74LS221 Dual monostable multivibrator	XO-666
C76	Capacitor, .001UF, 50V NPO CM-AX, 10%	XO-757	E1	74LS20 Dual 4-input "NAND" gate	XO-430
C77, C78, C79	Capacitor, 10UF, 10V TANT-AX, 10%	XO-209	E2	74LS244 Octal buffer/line driver	XO-117
ALL BYPASS CAPACITORS	.01UF, 50V CM-AX, +80%-20%	XO-229	E3	74LS32 Quad 2-input "OR" gate	XO-433
D1, D2	Diode, 1N4148	XO-261	G1	74LS164 8-bit SIPO shift register	XO-441
J3	Phono Jack, Right Angle	XO-618	G2	74LS374 Octal D-type flip flop	XO-96
J4	20 Pin DIP Socket	XO-491	H1	74LS164 8-bit SIPO shift register	XO-441
J5, J6	Phono Jack, Right Angle	XO-618	H2	74LS374 Octal D-type flip flop	XO-96
JP2, JP3	Header Conn. 2 Pin Stick	XO-123	K1	74LS164 8-bit SIPO shift register	XO-441
JP14, JP15	Header Conn. 2 Pin Stick	XO-123	K2	74LS244 Octal buffer/line driver	XO-117
	Template Jumper, Blue Plastic Cover	XO-122	M1	74LS244 Octal buffer/line driver	XO-117
P2	8 Pin Wafer Conn.	XO-339	M2	74LS165 8-bit PISO shift register	XO-80
Q1, Q2	Transistor, 2SC945	XO-316	M5	MC145388 Monostable multivibrator	XO-564
Q3	Transistor, 2N2222A	XO-320	N2	74LS04 Hex inverter	XO-418
R1	Resistor, 47 OHM, 5% 1/2W	XO-697	N3	74LS30 B-input "NAND" gate	XO-432
R2	Resistor, 47K OHM, 5% 1/4W	XO-30	N4	74LS161 Synchronous presettable binary counter	XO-440
R3	Resistor, 120K OHM, 5% 1/4W	XO-601	S1	HM6116P-4 2K x 8 RAM	XO-195
R4, R5	Resistor, 2.2K OHM, 5% 1/4W	XO-27	S2	74LS74 Dual D-type flip flop	XO-434
R6	Potentiometer, 50K OHM, 10% 1/4W	XO-675	S3	74LS00 Quad 2-input "NAND" gate	XO-427
R8, R9	Resistor, 1K OHM, 5% 1/4W	XO-5	S4	74LS08 Quad 2-input "AND" gate	XO-86
R10, R11	Resistor, 100K OHM, 1% 1/4W	XO-758	V1, V2, V3	74LS161 Synchronous presettable binary counter	XO-440
R12	Resistor, 2.2K OHM, 5% 1/4W	XO-27	V4	74LS74 Dual D-type flip flop	XO-434
R13	Resistor, 267K OHM, 1% 1/4W	XO-760	V5	MC145388 Monostable multivibrator	XO-564
R14, R15	Resistor, 249K OHM, 1% 1/4W	XO-759	W1	74LS191 Presettable 4-bit binary counter	XO-116
R16	Resistor, 267K OHM, 1% 1/4W	XO-76	W2	74LS74 Dual D-type flip flop	XO-434
			W3	74LS27 Triple 3-input "NOR" gate	XO-702
			W5	74LS04 Hex inverter	XO-418
			X1	74LS191 Presettable 4-bit binary counter	XO-116
			X2	74LS190 Presettable BCD to Decade counted	XO-701
			X3	NE555P Timer	XO-631
			X4	LM393 Dual voltage comparator	XO-396

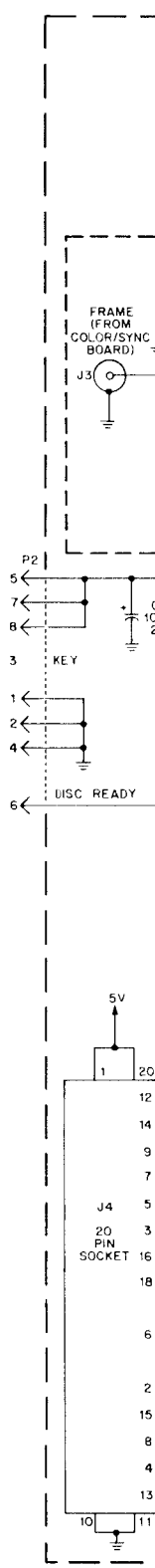

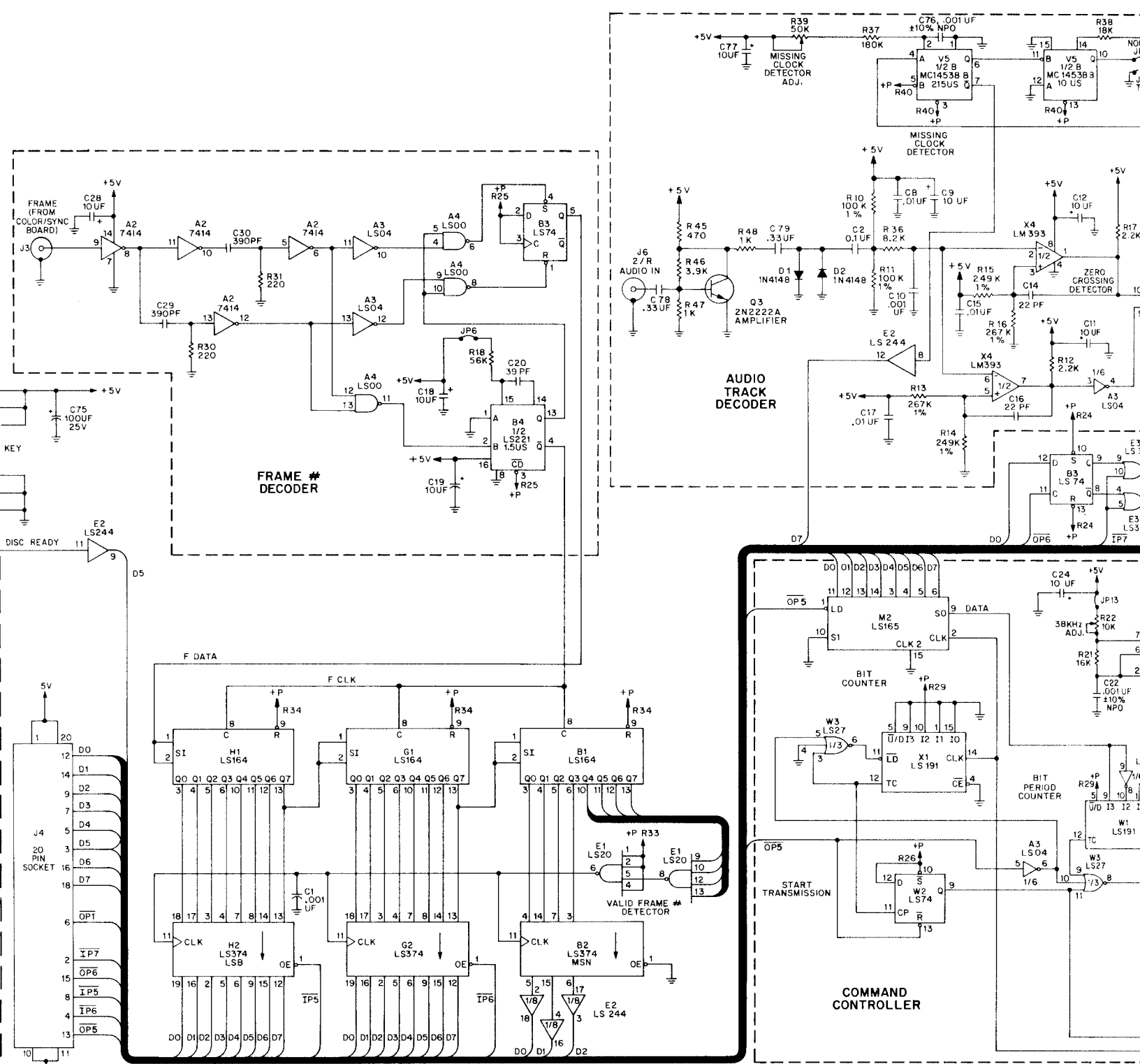

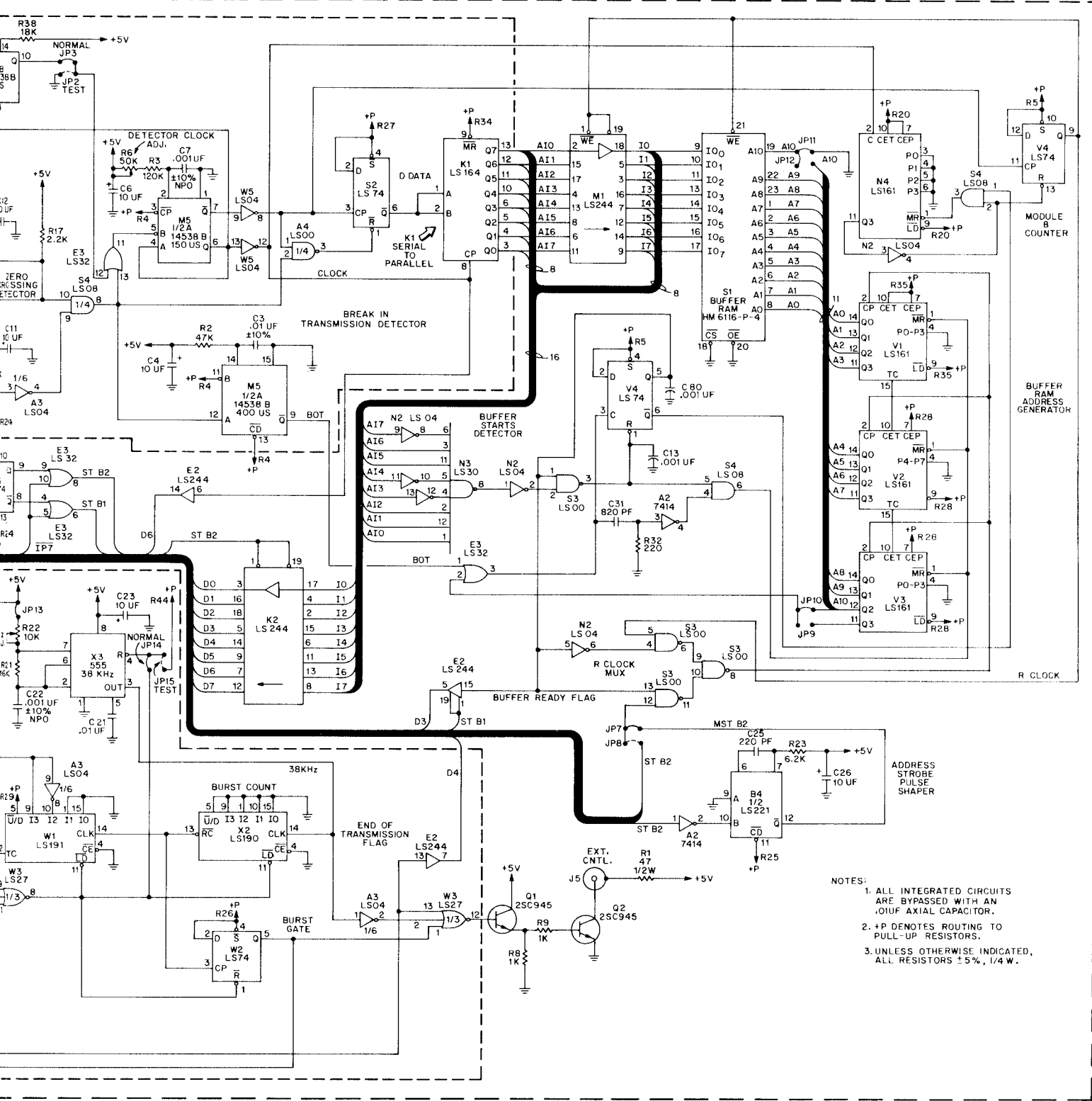

- NOTES:
1. ALL INTEGRATED CIRCUITS ARE BYPASSED WITH AN .01UF AXIAL CAPACITOR.
 2. +P DENOTES ROUTING TO PULL-UP RESISTORS.
 3. UNLESS OTHERWISE INDICATED, ALL RESISTORS 15%, 1/4 W.

INTERFACE BOARD ASSY. (A2), SCHEMATIC DIAGRAM

X. WIRING AND SCHEMATIC DIAGRAMS, PARTS LISTS

COLOR/SYNC BOARD ASSY. (A18), COMPONENT LOCATION

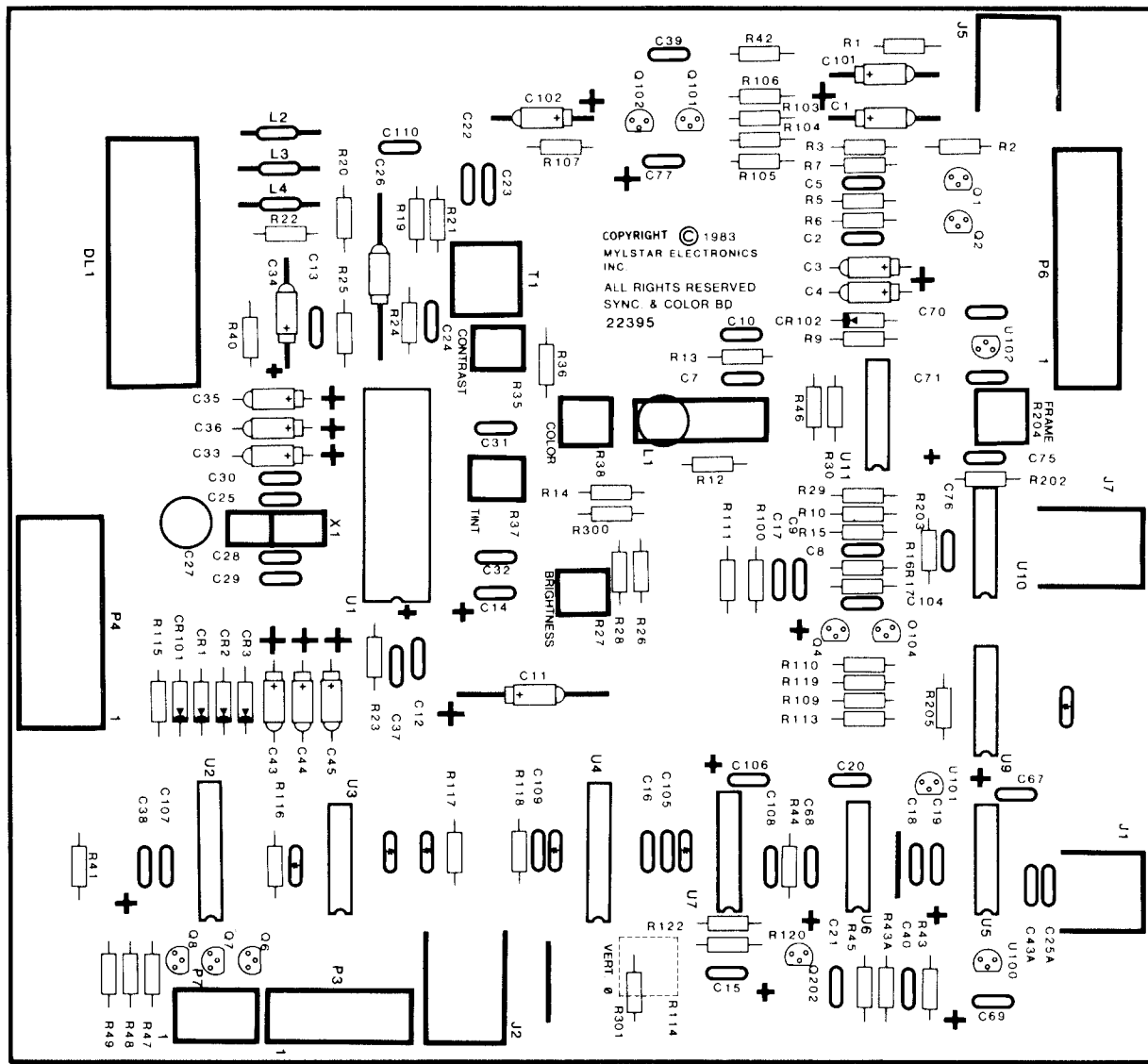

COLOR/SYNC BOARD ASSY. (A18), PARTS LIST

REFERENCE	DESCRIPTION	PART NO.	REFERENCE	DESCRIPTION	PART NO.	REFERENCE	DESCRIPTION	PART NO.
C1, C3, C9, C38, C101, C102, C2, C8, C12, C17, C18, C20, C24, C31, C40, C76, C104, C106, C4, C14, C43-C45, C67, C69, C75, C77	Color/Sync Board Assy. Capacitor, 10UF, 16V TANT-AX Capacitor, 01UF, 50V AX-CR, +80%-20% Capacitor, 39PF, 50V CM-AX Capacitor, 560PF, 50V CM-AX, 10% Capacitor, 100UF, 16V ELEC-AX Capacitor, 22UF, 50V CM-AX, 20% Capacitor, 10UF, 10V TANT-AX, 10% Capacitor, 001UF, 50V NPO CM-AX, 10% Capacitor, 220PF, 50V CM-AX, 10% Capacitor, 100PF, 50V CM-AX, 10% Capacitor, 10UF, 25V AX-Non Polarized Capacitor, Trimmer, 5-50PF CM Capacitor, 22PF, 50V CM-AX, 10% Capacitor, 390PF, 50V CM-AX, 10% Capacitor, 15PF, 50V CM-AX, 10% Capacitor, 22UF, 16V TANT-AX, 10% Capacitor, 4.7UF, 16V TANT-AX Capacitor, 2.2UF, 16V TANT-AX, 10% Capacitor, 68PF, 50V CM-AX, 10% Capacitor, 0.1UF, 50V CM-Bypass Capacitor, 220PF, 50V CM-AX, +80%-20%	MA-497 XO-749 XO-229 XO-753 XO-334 XO-681 XO-755 XO-688 XO-209 XO-757 XO-682 XO-680 XO-750 XO-653 XO-683 XO-684 XO-685 XO-752 XO-754 XO-751 XO-636 XO-558 XO-694	CR1, CR2, CR3, CR101, CR102 DL1 J1, J2 J5, J7 L1 L2 L3 L4 P3 P4 P6 P7 Q1, Q2, Q6, Q7, Q8, Q101, Q102, Q104 Q4 Q202 R1 R2, R5, R12, R14, R24, R41, R42, R202 R3 R6, R119 R7 R8, R20, R105 R9, R103, R113 R13 R15, R100 R16, R104 R17 R19 R21 R22, R122, R205 R23 R25 R26, R36	Diode, 1N4148 Delay Line, 400NS Phono Jack, Right Angle RF Choke, 8.5 MH Inductor, 27UH, 10% Inductor, 4.7UH, 10% Inductor, 68UH, 10% 6 Pin Wafer Conn. Header Conn., 26 Pin 9 Pin Wafer Conn 3 Pin Wafer Conn. Transistor, 25C945, NPN Transistor, 2N3906, PNP Transistor, MPS-A13, NPN Resistor, 75 OHM, 5% 1/4W Resistor, 1K OHM, 5% 1/4W Resistor, 12K OHM, 5% 1/4W Resistor, 2.7K OHM, 5% 1/4W Resistor, 5.1K OHM, 5% 1/4W Resistor, 1.5K OHM, 5% 1/4W Resistor, 10K OHM, 5% 1/4W Resistor, 22K OHM, 5% 1/4W Resistor, 4.7K OHM, 5% 1/4W Resistor, 27K OHM, 5% 1/4W Resistor, 680K OHM, 5% 1/4W Resistor, 330 OHM, 5% 1/4W Resistor, 47 OHM, 5% 1/4W Resistor, 2.2K OHM, 5% 1/4W Resistor, 300K OHM, 5% 1/4W Resistor, 330K OHM, 5% 1/4W Resistor, 5.6K OHM, 5% 1/4W	XO-261 XO-654 XO-618 XO-659 XO-658 XO-657 XO-373 XO-651 XO-375 XO-703 XO-316 XO-588 XO-304 XO-667 XO-5 XO-9 XO-6 XO-40 XO-20 XO-18 XO-42 XO-7 XO-11 XO-669 XO-34 XO-50 XO-27 XO-670 XO-47 XO-19	R27, R35, R37, R38 R28 R43, R43A R44, R109 R45 R47, R48, R49 R106 R107 R110, R115 R112, R116 R117 R118 R120 R204 R300 R301 R301 T1 U1 U2 U3 U4 U5 U6 U7 U9 U10 U11 U100, U101 U102 X1	Potentiometer, 10K OHM, 5% 1/4W Resistor, 20K OHM, 5% 1/4W Resistor, 300 OHM, 5% 1/4W Resistor, 1.2K OHM, 5% 1/4W Resistor, 180 OHM, 5% 1/4W Resistor, 560 OHM, 5% 1/4W Resistor, 3.9K OHM, 5% 1/4W Resistor, 3K OHM, 5% 1/4W Resistor, 470 OHM, 5% 1/4W Resistor, 240 OHM, 5% 1/4W Resistor, 220K OHM, 5% 1/4W Resistor, 68K OHM, 5% 1/4W Potentiometer, 1K OHM, 10% 1/4W Resistor, 150 OHM, 5% 1/4W Resistor, 15K OHM, 5% 1/4W Transformer, 3.58 MHz Bandpass UPC1352C Chrominance and Luminance processor MC14551 Quad 2-input multiplexor 7407 Hex buffer/driver MC14538B Monostable multivibrator MC4024 Dual voltage controlled multivibrator MC4044 Phase-frequency detector 74LS221 Dual Monostable multivibrator 74LS74 Dual D-type flip flop 75107A Dual line receivers/drivers 7404 Hex inverter 78L05 Positive 5VDC regulator 79L05 Negative 5VDC regulator Crystal, 3.579 MHz 28 Pin DIP Socket	XO-674 XO-41 XO-174 XO-671 XO-39 XO-175 XO-24 XO-36 XO-39 XO-23 XO-35 XO-173 XO-594 XO-189 XO-756 XO-574 XO-22 XO-655 XO-650 XO-660 XO-384 XO-564 XO-446 XO-447 XO-666 XO-434 XO-664 XO-402 XO-662 XO-661 XO-456 XO-536

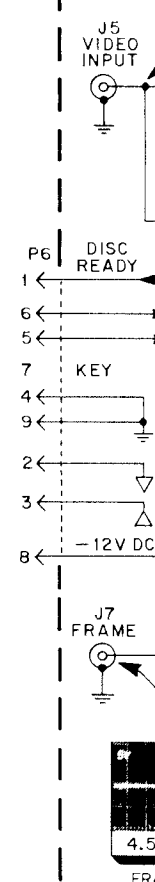

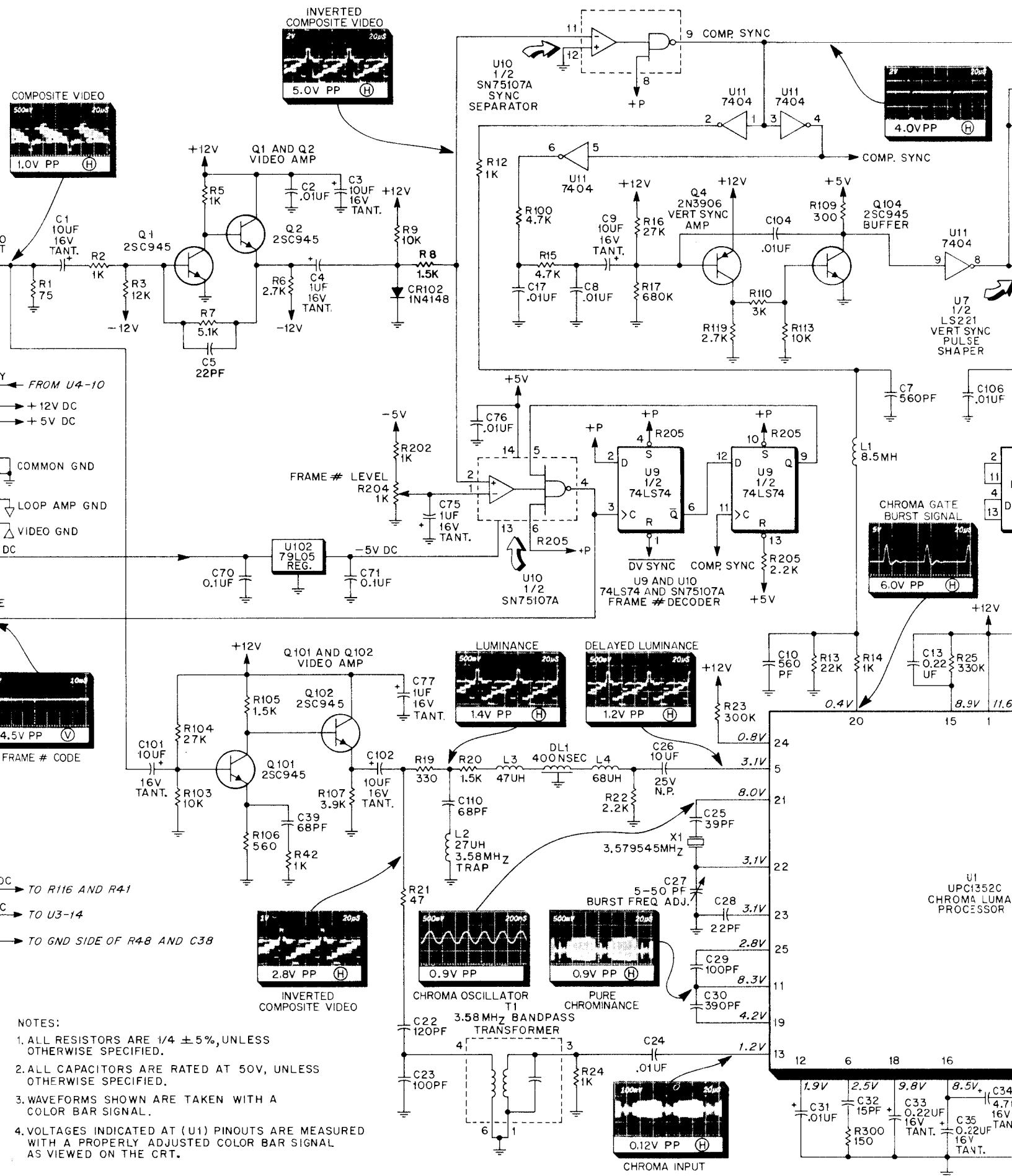

- NOTES:
1. ALL RESISTORS ARE 1/4 ±5%, UNLESS OTHERWISE SPECIFIED.
 2. ALL CAPACITORS ARE RATED AT 50V, UNLESS OTHERWISE SPECIFIED.
 3. WAVEFORMS SHOWN ARE TAKEN WITH A COLOR BAR SIGNAL.
 4. VOLTAGES INDICATED AT (U1) PINOUTS ARE MEASURED WITH A PROPERLY ADJUSTED COLOR BAR SIGNAL AS VIEWED ON THE CRT.

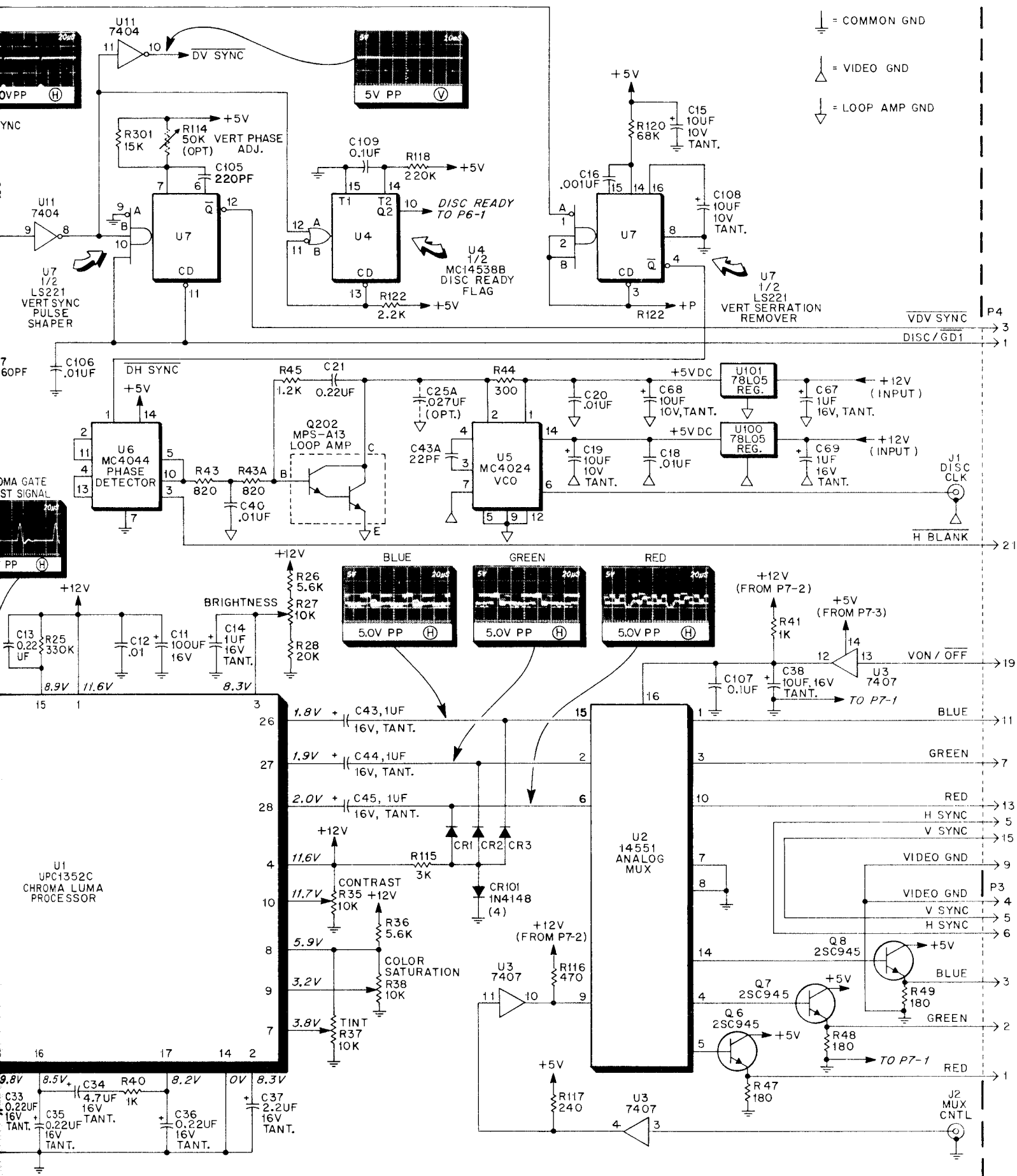

COLOR/SYNC BOARD ASSY. (A18), SCHEMATIC DIAGRAM

X. WIRING AND SCHEMATIC DIAGRAMS, PARTS LISTS

SOUND BOARD (A6) COMPONENT LOCATION

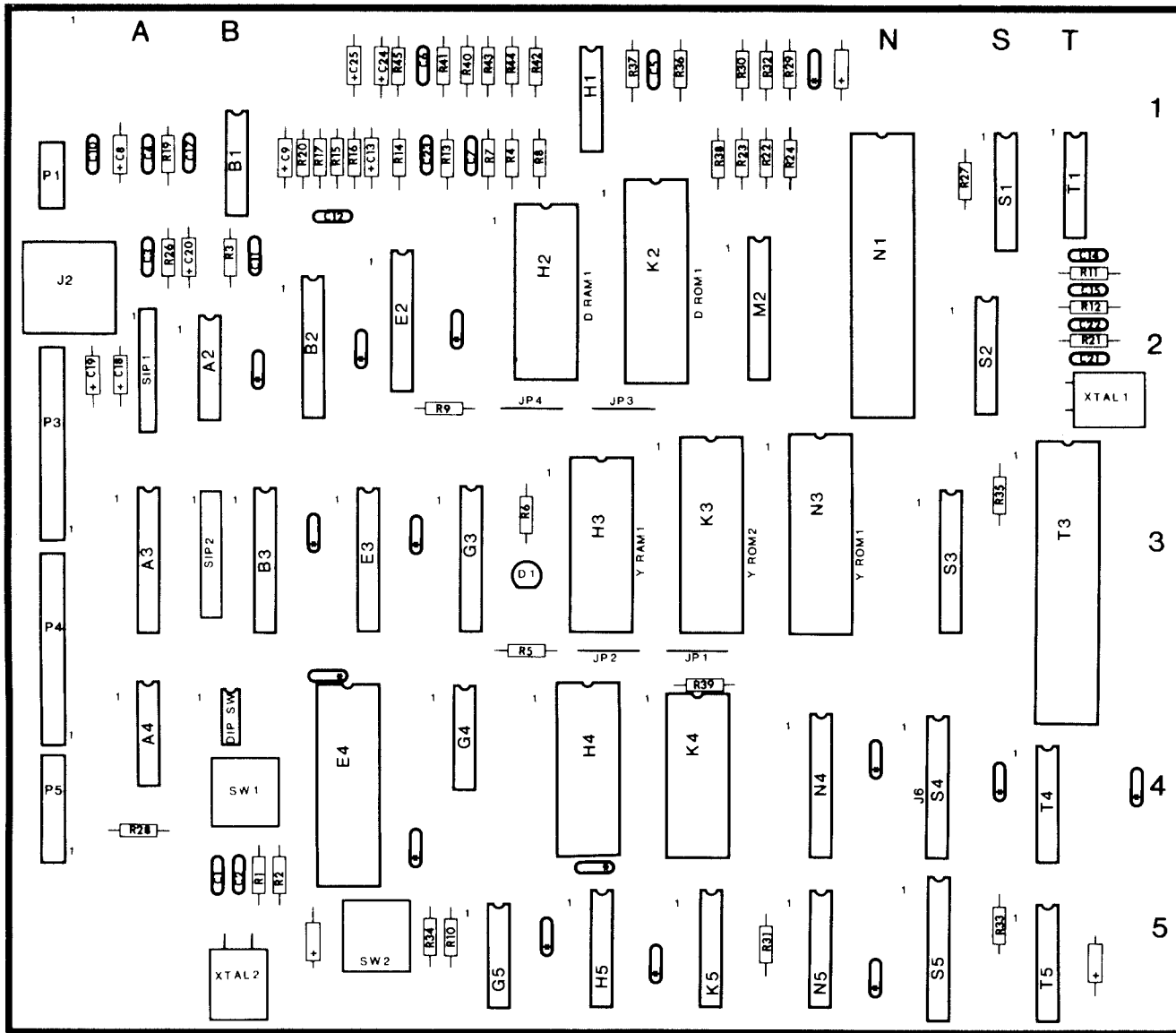

SOUND BOARD (A6) PARTS LIST

REFERENCE	DESCRIPTION	PART NO.	REFERENCE	DESCRIPTION	PART NO.
	Sound Board Assy.	MA-495			
C1, C2	Capacitor, 22PF, 50V MONO AX-CM, 10%	XO-633	R6	Resistor, 240 OHM, 5% 1/4W	XO-173
C3, C21	Capacitor, 0.1UF, 50V MONO AX-GL	XO-637	R11, R12	Resistor, 470 OHM, 5% 1/4W	XO-35
C5, C6	Capacitor, .01UF, 50V MONO AX-GL, 10%	XO-747	R14	Resistor, 6.8K OHM, 5% 1/4W	XO-8
C7, C17, C23	Capacitor, 1UF, 50V CM-RD Non-Polarized	XO-294	R15, R20	Resistor, 1.2K OHM, 5% 1/4W	XO-175
C8, C9, C10	Capacitor, 10UF, 25V TANT-AX, 10%	XO-127	R16, R17, R19, R26, R29, R30, R32, R37, R38, R40-R44	Resistor, 10K OHM, 5% 1/4W	XO-18
C18, C19, C24, C25	Capacitor, 1UF, 50V TANT-AX, 10%	XO-217	R36, R45	Resistor, 33K OHM, 5% 1/4W	XO-43
C11	Capacitor, 10PF, 50V AX-CM, +80%-20%	XO-635	SIP1, SIP2	Resistor Pack, Sip, 1K OHM, 9 Pin	XO-493
C13, C20	Capacitor, 1UF, 50V TANT-AX	XO-217	SW1, SW2	Switch, Push Button, N.O.	XO-365
C14	Capacitor, 68PF, 50V MONO AX-CM, 10%	XO-636	XTAL1	Crystal, 4.0 MHz	XO-366
C15	Capacitor, .047UF, 50V MONO AX-CM, 20%	XO-638	XTAL2	Crystal, 3.12 MHz	XO-639
ALL UNMARKED CAPACITORS	0.1UF, 50V CM-AX	XO-230		24 Pin DIP Socket	XO-529
ALL UNMARKED POLARIZED CAPACITORS	10UF, 25V TANT-AX, 10%	XO-127		28 Pin DIP Socket	XO-536
D1	Diode, MV5752	XO-270		40 Pin DIP Socket	XO-530
DIP SW	DIP Switch, 4 Position, 8 Pin	XO-640	A2	7430 8-input "NAND" gate	XO-643
J2	Phone Jack	XO-744	A3, B2	74LS373 Octal D-type flip flop	XO-445
P1	3 Pin Wafer Conn.	XO-703	A4	74LS74 Dual D-type flip flop	XO-434
P3, P4	9 Pin Wafer Conn.	XO-375	B1, H1	LM324 Quad op-amp	XO-644
R1	Resistor, 10M OHM, 5% 1/4W	XO-73	B3	74LS244 Octal buffer/line driver	XO-117
R2, R5, R9, R10, R27, R28, R31, R33-R35, R39	Resistor, 1K OHM, 5% 1/4W	XO-5	E2	AD7528J DAC	XO-647
R3, R13	Resistor, 4.7K OHM, 5% 1/4W	XO-7	E3, G3, N4, S5	74LS374 Octal D-type flip flop	XO-96
R4, R7, R8, R22-R24	Resistor, 68 OHM, 5% 1/4W	XO-748	E4	SP0250 Speech generator	XO-645
			G4, T1	74LS04 Hex inverter	XO-418
			G5	74LS08 Quad 2-input "AND" gate	XO-86
			H2, H3	4801 1K x 8 SRAM	XO-193
			H4, K4	AY-3-8913 Sound generator	XO-646
			H5, K5, N5, S1, T5	74161 Synchronous presettable binary counter	XO-192
			K2, K3, N3	2732A 4K x 8 EPROM	XO-485
			N1, T3	R6502-13 CPU	XO-360
			N2, S3	74LS245 Octal bus transceiver	XO-79
			S2	74LS139 Dual 1 of 4 decoder	XO-419
			T4	74LS138 1 of 8 decoder/demultiplexor	XO-437

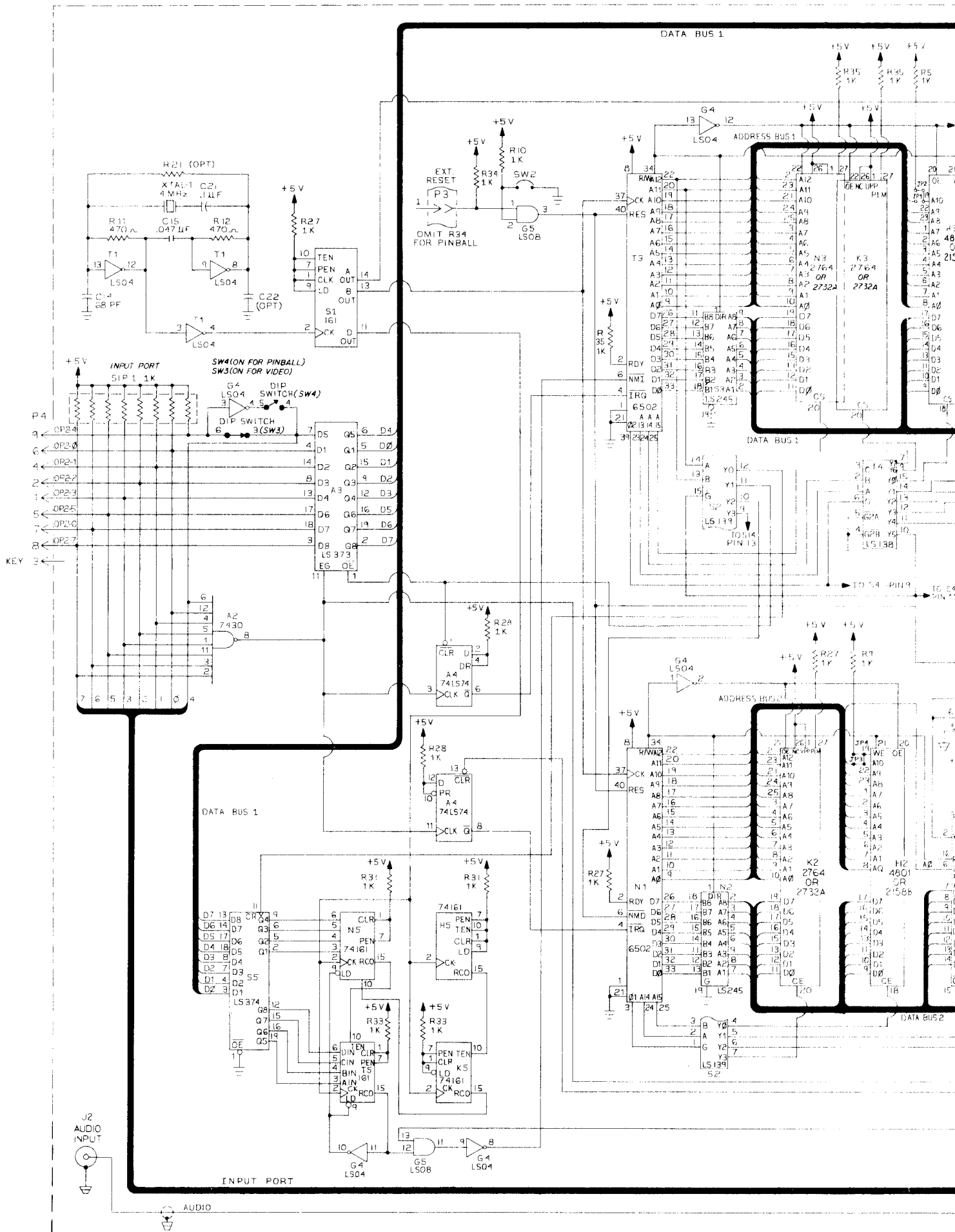

C DIAGRAMS, PARTS LISTS

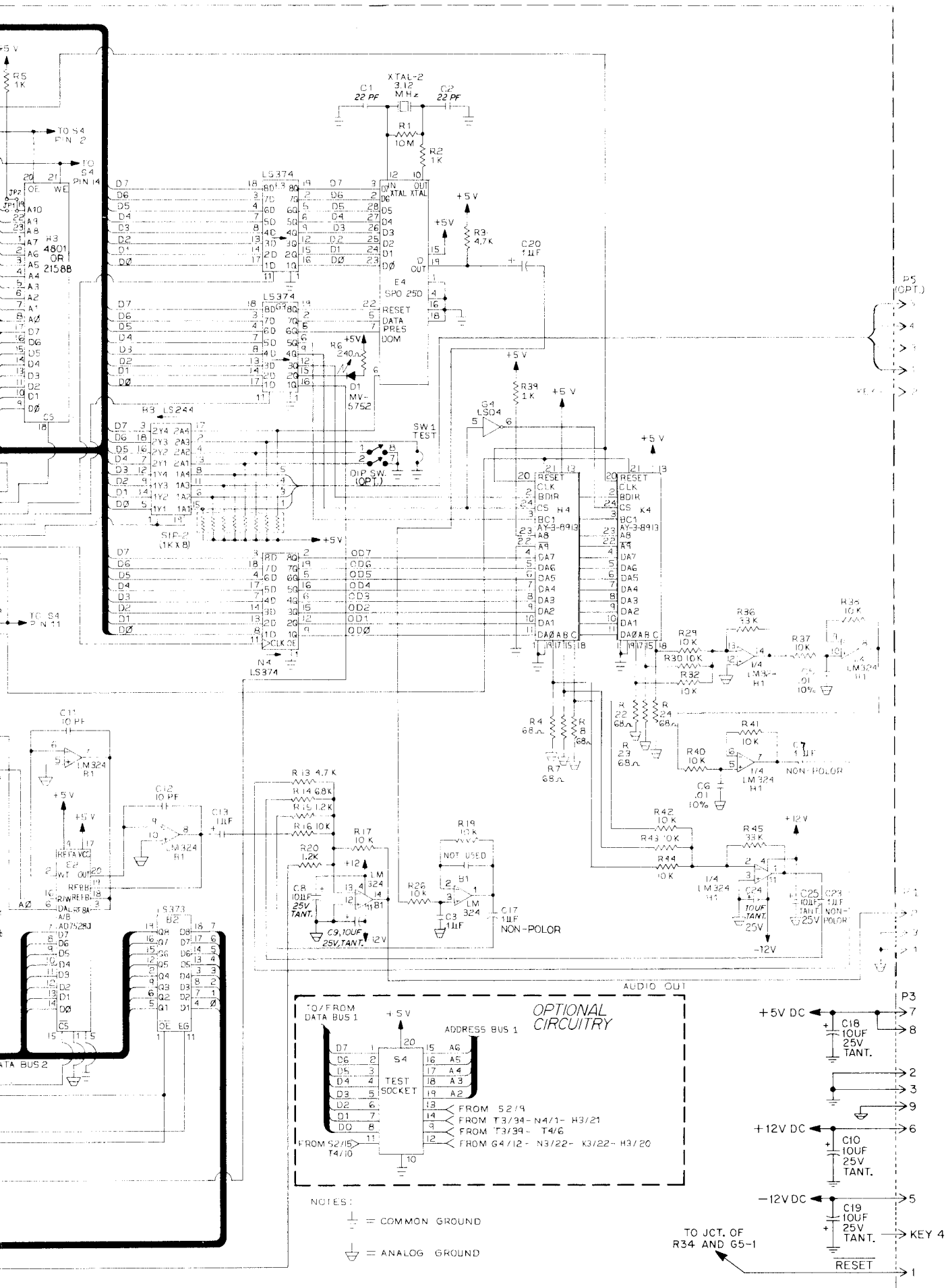

NOTES:
 = COMMON GROUND
 = ANALOG GROUND

SOUND BOARD ASSY. (A6), SCHEMATIC DIAGRAM

X. WIRING AND SCHEMATIC DIAGRAMS, PARTS LISTS

POWER SUPPLY ASSY. (A3), COMPONENT LOCATION

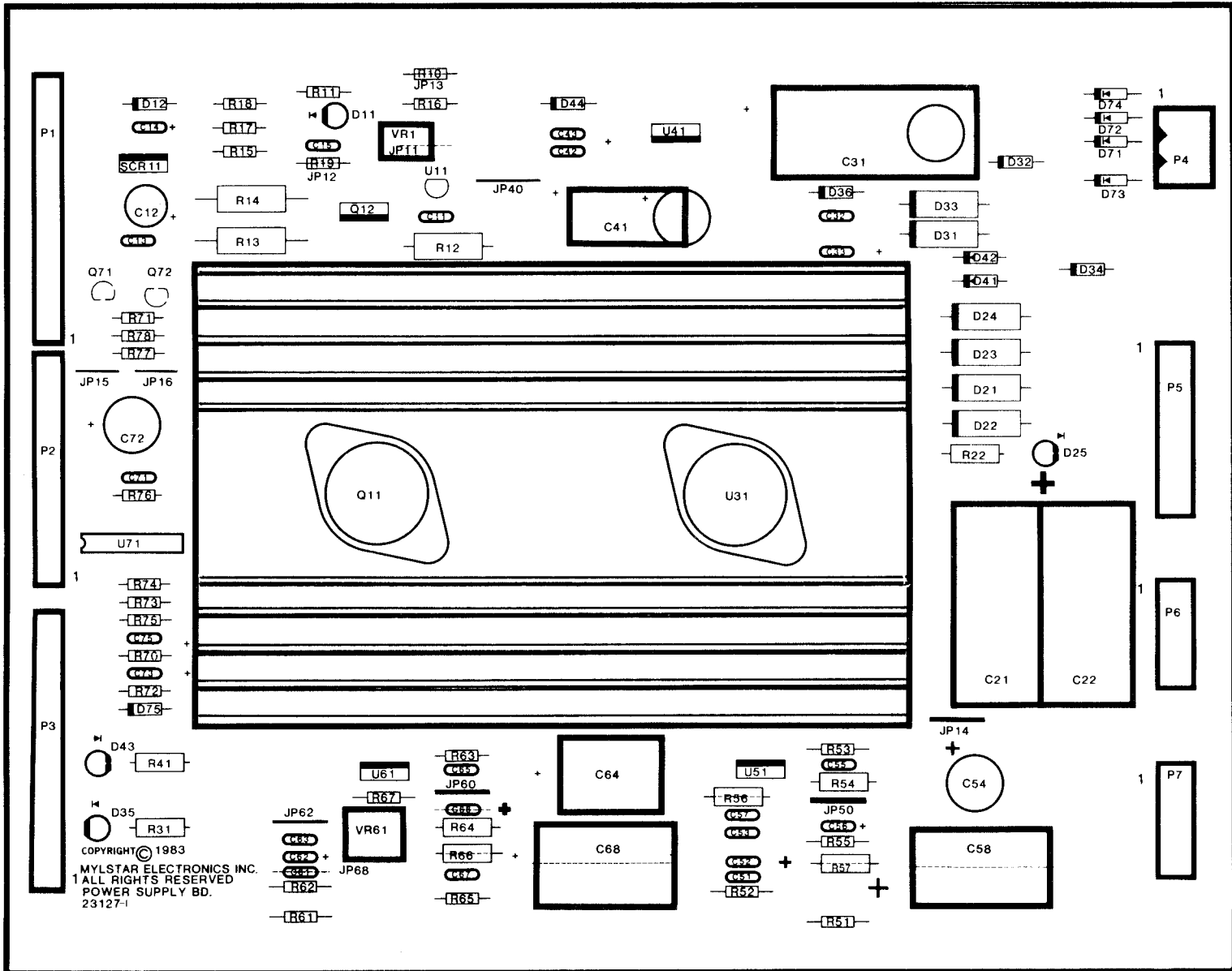

POWER SUPPLY ASSY. (A3), PARTS LIST

REFERENCE	DESCRIPTION	PART NO.	REFERENCE	DESCRIPTION	PART NO.
C11, C32, C42, C55, C71	Power Supply Assembly	MA-479			
C12	Capacitor, .01UF, 50V	XO-229	R12	Resistor, 100 OHM, 5%, 1W	XO-137
C13, C57	Capacitor, 100UF, 16V	XO-235	R13, R14	Resistor, 12 OHM, 5%, 3W	XO-138
C14, C33, C43	Capacitor, .1UF, 50V	XO-558	R15	Resistor, 200 OHM, 5%, 1/4W	XO-143
C21	Capacitor, .22UF, 35V	XO-615	R17, R52, R53	Resistor, 100 OHM, 5%, 1/4W	XO-28
C31	Capacitor, 2200UF, 25V	XO-346	R18	Resistor, 20 OHM, 5%, 1/4W	XO-29
C41, C54, C72	Capacitor, 1500UF, 35V	XO-616	R22	Resistor, 470 OHM, 5%, 1/4W	XO-55
C52, C56	Capacitor, 470UF, 35V	XO-284	R31, R41	Resistor, 560 OHM, 5%, 1/4W	XO-36
C58	Capacitor, 1UF, 35V	XO-715	R51	Resistor, 51.1K OHM, 5%, 1/4W	XO-40
C73, C75	Capacitor, 1000UF, 25V	XO-218	R54	Resistor, 220 OHM, 5%, 1/4W	XO-185
D11, D25, D35, D43	Diode, Light Emitting MV-5752	XO-270	R55	Resistor, 2.2 OHM, 5%, 1/4W	XO-595
D12	Diode, Zener, 5.6V, 1N4734A	XO-255	R56	Resistor, 1 OHM, 5%, 1/2W	XO-593
D21-D24, D31, D33	Diode, 1N5401	XO-263	R70	Resistor, 1K OHM, 5%, 1/4W	XO-5
D32, D34, D36, D41, D42, D44	Diode, 1N4004	XO-254	R71, R73, R77	Resistor, 10K OHM, 5%, 1/4W	XO-18
D71-D75	Diode, 1N4148	XO-261	R72	Resistor, 110K OHM, 5%, 1/4W	XO-591
Q11	Transistor, PNP, 2N5879	XO-323	R74	Resistor, 560K OHM, 5%, 1/4W	XO-704
Q12	Transistor, TIP31B	XO-641	R75	Resistor, 2K OHM, 5%, 1/4W	XO-14
Q71	Transistor, PNP, 2N3906	XO-588	R76	Resistor, 4.7K OHM, 5%, 1/4W	XO-7
Q72	Transistor, NPN, 2N3904	XO-549	R78	Resistor, 100 OHM, 5%, 1/4W	XO-52
R11, R16	Resistor, 180 OHM, 5%, 1/4W	XO-24	SCR68-1	Silicon Controlled Rectifier	XO-131
			U11	Voltage Regulator, Zener TL431	XO-272
			U31	Voltage Regulator, -12V, LM340K	XO-628
			U41	Voltage Regulator, -12V, LM320T	XO-613
			U51	Audio Amplifier, LM200T	XO-550
			U71	IC, CMOS	XO-564
			VR1	Potentiometer, 100 OHM	XO-134

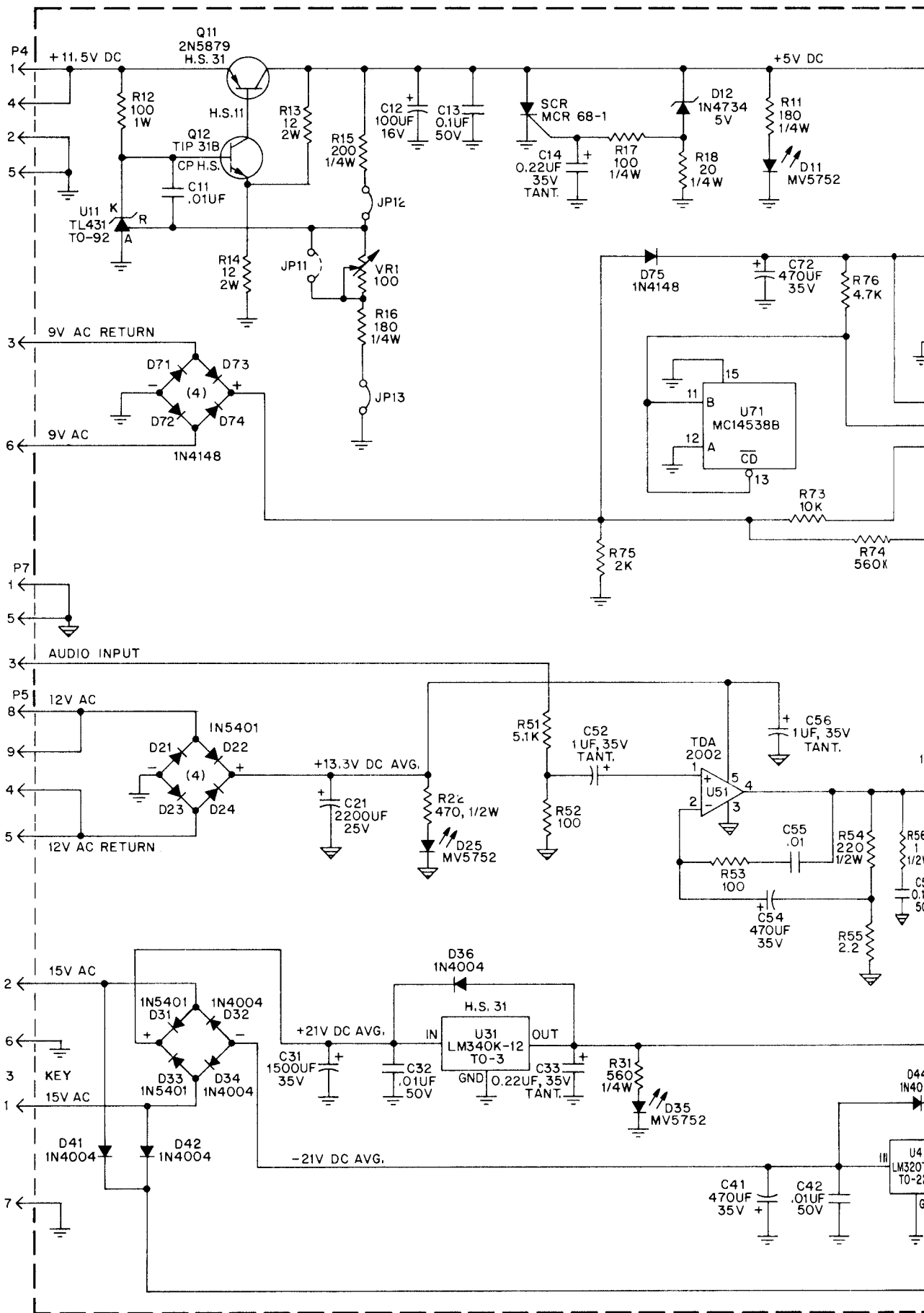

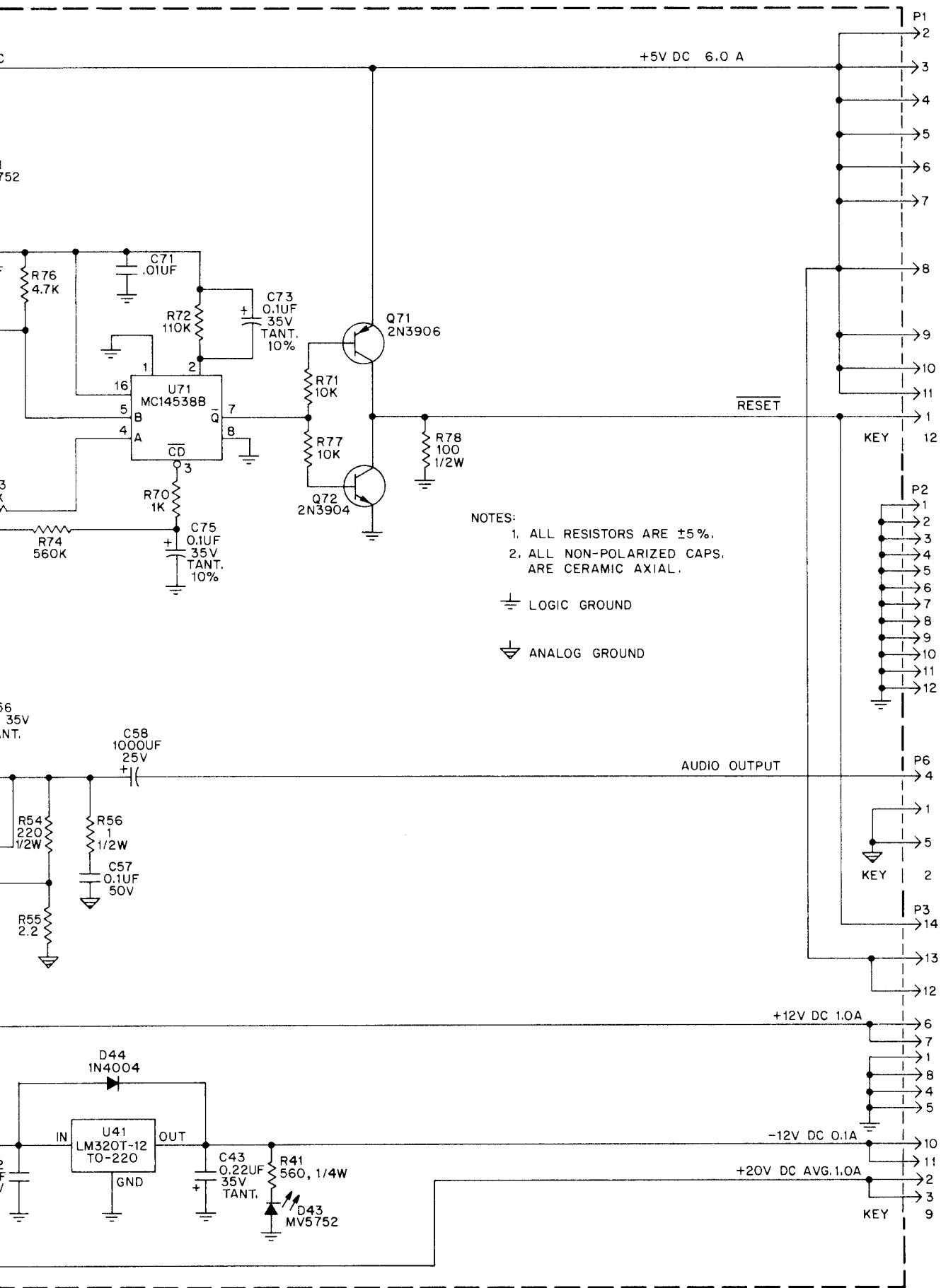

NOTES:
 1. ALL RESISTORS ARE $\pm 5\%$.
 2. ALL NON-POLARIZED CAPS. ARE CERAMIC AXIAL.

⏏ LOGIC GROUND
 ⏏ ANALOG GROUND

POWER SUPPLY ASSY. (A3), SCHEMATIC DIAGRAM

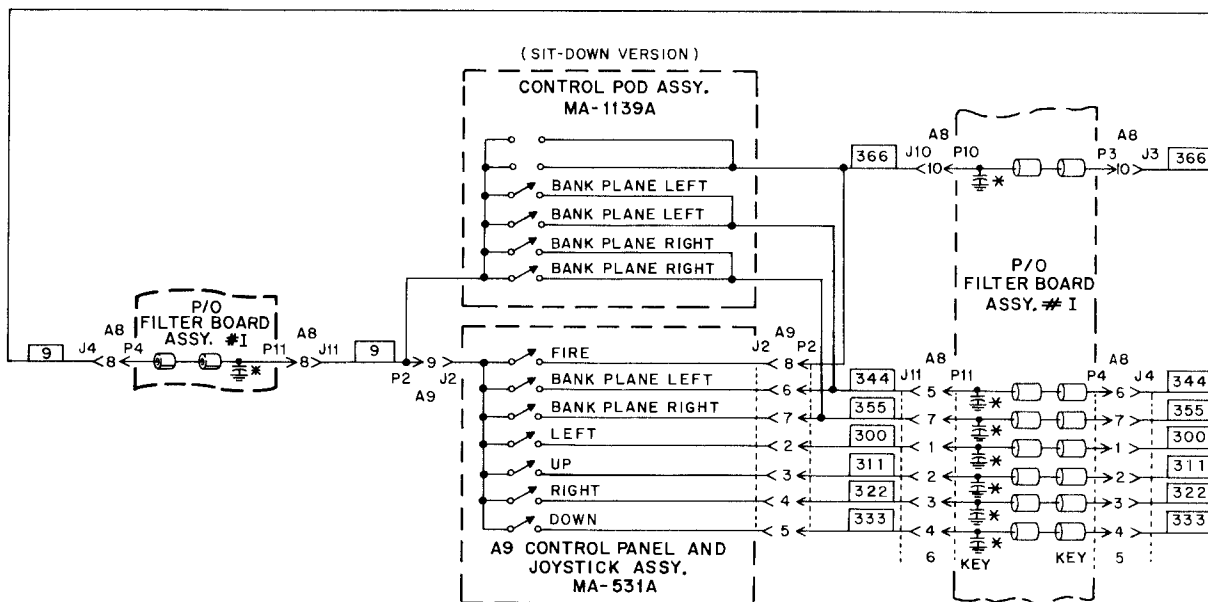
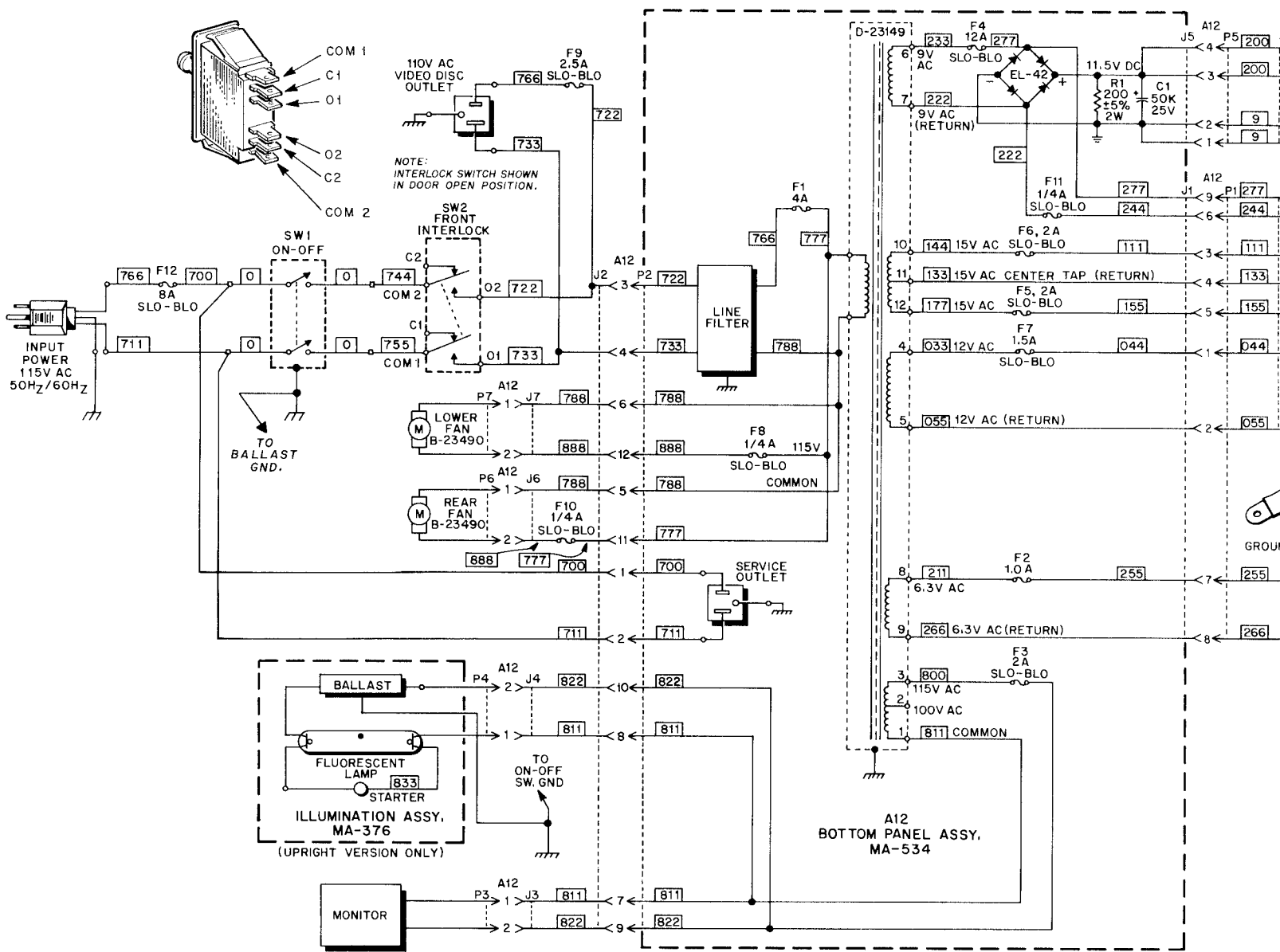

X. WIRING AND SCHEMATIC DIAGRAMS, PARTS LISTS

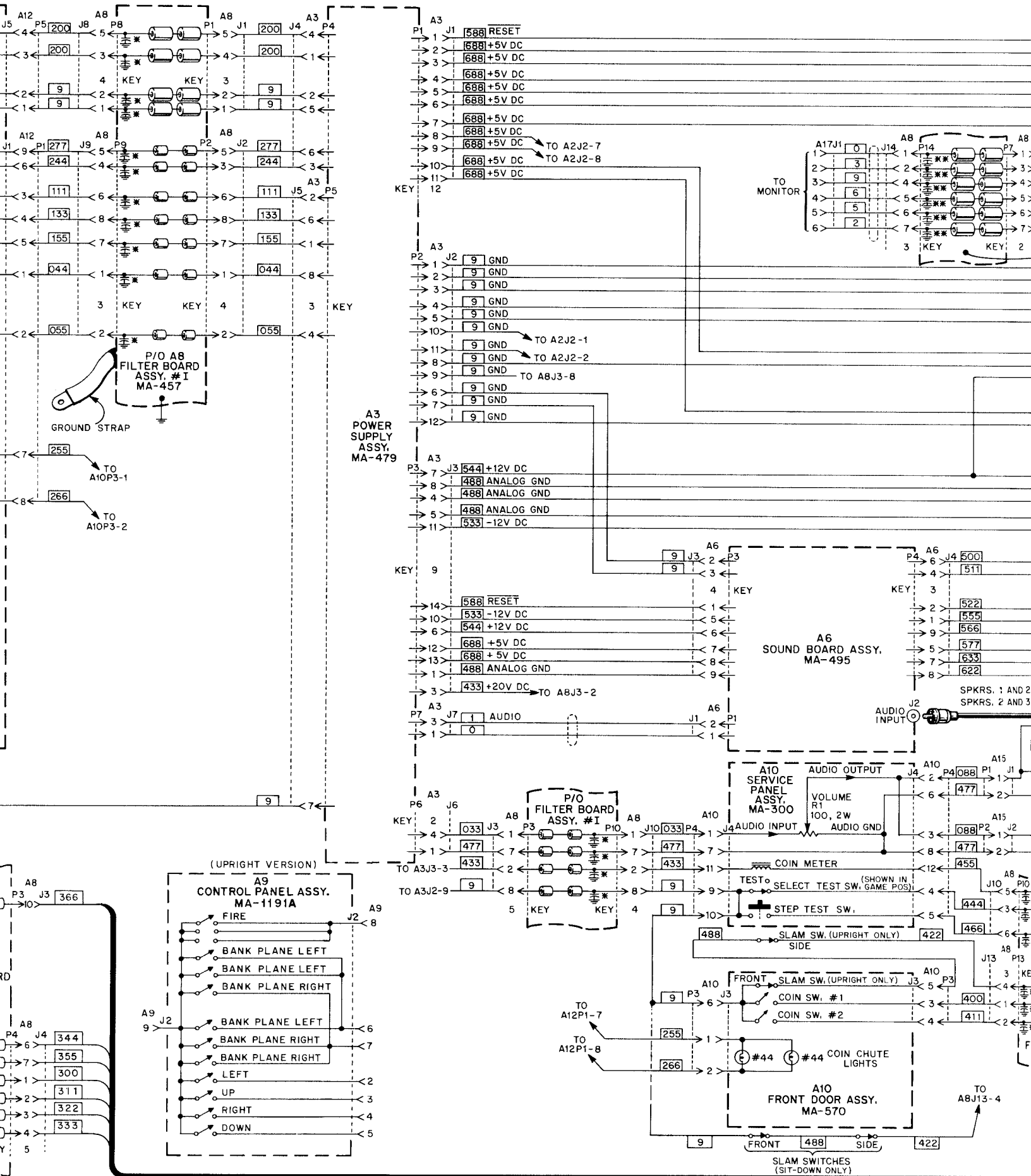

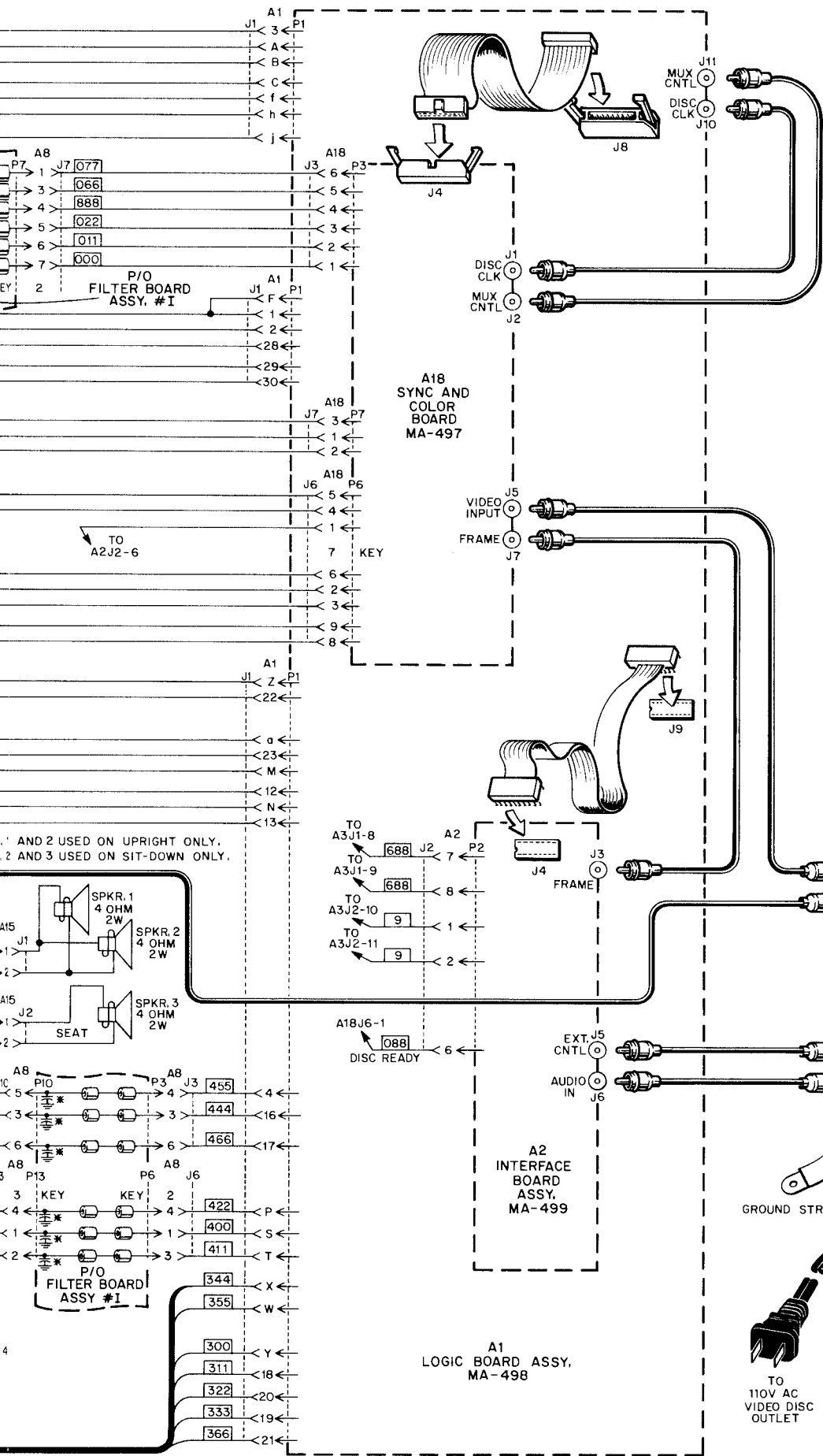

COLOR CODE	
0	BLACK
1	BROWN
2	RED
3	ORANGE
4	YELLOW
5	GREEN
6	BLUE
7	PURPLE
8	GRAY
9	WHITE

- NOTES:
1. [XXX] INDICATES WIRE COLOR
 2. ⊕ INDICATES CIRCUIT GROUND
 3. ⚡ INDICATES EARTH GROUND
 4. * INDICATES .01UF
 5. ** INDICATES 39PF
 6. † INDICATES .001UF

MISCELLANEOUS CABLES			
FROM	TO	DESCRIPTION	PART NO.
A1-J8	A18-J4	RIBBON CABLE	23504
A1-J9	A2-J4	RIBBON CABLE	A-22941
A1-J10	A18-J1	3-1/2" 75 OHM COAX	23558
A1-J11	A18-J2	3-1/2" 75 OHM COAX	23558
A2-J3	A18-J7	26" AUD COAX	23555
A2-J5	A8-J21	6" AUD COAX	23556
A2-J6	A8-J23	8" AUD COAX	23557
A8-J17	A18-J5	37" 75 OHM COAX	23554
A8-J18	VIDEO OUT	60" 75 OHM COAX	23559
A8-J19	A6-J2	26" AUD COAX	23555
A8-J20	1/L	60" AUD COAX	23560
A8-J22	EXT CONTROL	60" AUD COAX	23562
A8-J24	2/R	60" AUD COAX	23561
A3-J7	A6-J1	CABLE	23553

1 AND 2 USED ON UPRIGHT ONLY.
2 AND 3 USED ON SIT-DOWN ONLY.

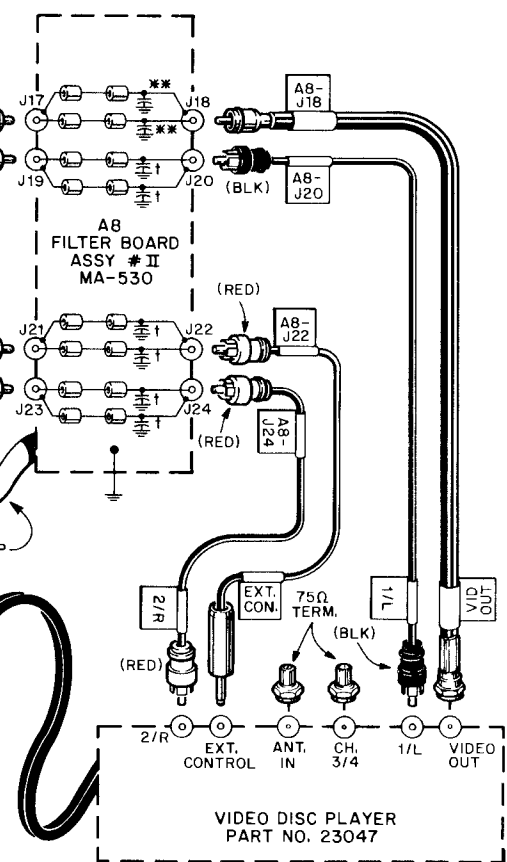
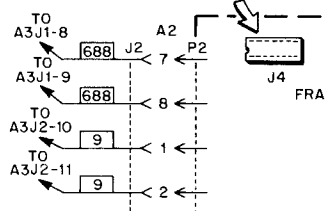
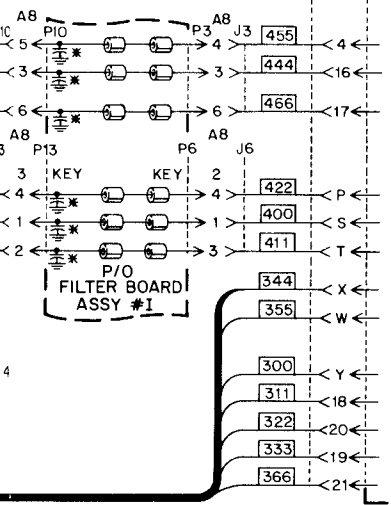
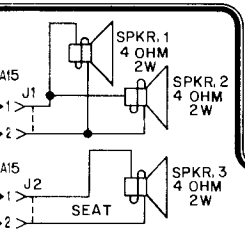

PRIMARY POWER/FILTER BOARDS/INTERCONNECTION DIAGRAM

XI. PARTS INFORMATION

TABLE OF CONTENTS (UPRIGHT VERSION), (SIT-DOWN VERSION)

	PAGE
SPEAKER/MARQUEE ASSY.	54
ILLUMINATION ASSY.	54
CONTROL PANEL ASSY.	54
SERVICE PANEL ASSY.	54
BOTTOM PANEL ASSY.	54
CABINET PARTS (INTERIOR)	55
CABINET PARTS (EXTERIOR)	55
FILTER BOARD I	55
FILTER BOARD II	55

XI. PARTS INFORMATION

SPEAKER/MARQUEE ASSY., ILLUMINATION ASSY.

ITEM	DESCRIPTION	PART NO.	
		UPRIGHT	SIT-DOWN
1.	Illumination Assembly	MA-554	N/A
2.	Starter	EL-69	N/A
3.	Ballast (60 Hz)	EL-70	N/A
4.	Lamp, Fluorescent	LA-4	N/A
5.	Cable Assembly (Illumination)	MA-563	N/A
6.	Cable Assembly (Speaker)	MA-318	N/A
7.	Speaker	EL-83	N/A
8.	Speaker Grill	20931	N/A
9.	Illumination Trim	23067	N/A
10.	Marquee, Lexan	23928	N/A

CONTROL PANEL ASSY.

ITEM	DESCRIPTION	PART NO.	
		UPRIGHT	SIT-DOWN
1.	Control Panel Assembly	MA-1125A	MA-531A
2.	Control Pod Assembly	N/A	MA-1139A
3.	Lexan Overlay	23929	23932
4.	Joystick	23566	23566
5.	Control Panel Hinge	23621	23486
6.	Button, Orange	N/A	23502
7.	Button, Yellow	N/A	23510
8.	Button	21970	N/A
9.	Button, Holder & Switch	21971	23503
10.	Button Nuts	21972	21972
11.	Cable Assembly	MA-641	MA-642

SERVICE PANEL ASSY.

ITEM	DESCRIPTION	PART NO.	
		UPRIGHT	SIT-DOWN
1.	Service Panel Assembly	MA-550	MA-300
2.	Coin Meter	EL-84	EL-84
3.	Volume Control	XO-199	XO-199
4.	Switch (Push Button)	EL-57	EL-57
5.	Switch (Toggle)	23506	EL-85
6.	Cable Assembly	MA-559	MA-539

BOTTOM PANEL ASSY.

ITEM	DESCRIPTION	PART NO.	
		UPRIGHT	SIT-DOWN
1.	Bottom Panel Assembly	MA-534	MA-534
2.	Transformer	23149	23149
3.	Capacitor, 50,000 UF, 25V	XO-342	XO-342
4.	Resistor, 200 OHM, 5%, 2W	XO-142	XO-142
5.	Bridge Rectifier	EL-42	EL-42
6.	Fuse, 1½ AMP, SLO-BLO	EL-34	EL-34
7.	Fuse, 2 AMP, SLO-BLO	EL-7	EL-7
8.	Fuse, 12 AMP	FSI-83	FSI-83
9.	Fuse, 4 AMP, SLO-BLO	EL-33	EL-33
10.	Fuse, 1 AMP, SLO-BLO	EL-6	EL-6
11.	Fuse, 3/8 AMP, SLO-BLO	EL-37	EL-37
12.	Service Outlet	18133	18133
13.	Line Filter	EL-50	EL-50
14.	Cable Assembly (Primary)	MA-557	MA-538
15.	Cable Assembly (Secondary)	MA-537	MA-537

XI. PARTS INFORMATION

CABINET PARTS (INTERIOR)

ITEM	DESCRIPTION	PART NO.	
		UPRIGHT	SIT-DOWN
1.	Back Door	23633	23372
2.	Interconnect Cable	MA-561	MA-543
3.	Cable Assembly, Master Electronics	MA-558	MA-544
4.	Master Electronics Board	MA-1127	MA-1159
5.	Bottom Panel Assembly	MA-534	MA-534
6.	Sound/Speech Board Assembly	MA-495	MA-495
7.	Power Supply Assembly	MA-479	MA-479
8.	Logic Board Assembly	MA-498	MA-498
9.	Color/Sync Board Assembly	MA-497	MA-497
10.	Interface Board Assembly	MA-499	MA-499
11.	Filter Board I Assembly	MA-457	MA-457
12.	Filter Board II Assembly	MA-530	MA-530
13.	Shield, Top	23619	23495
14.	Shield, Bottom	23620	23494
15.	Clamp Bracket, Shield	23634	23493
16.	Cable Assembly, High Voltage	MA-556	MA-547
17.	Cable Assembly, Monitor	23756	23756
18.	Cable Assembly, Front Door	MA-540	MA-540
19.	Cable Assembly, Fan	MA-562	MA-562
20.	Line Cord	23365	23365
21.	Cover Plate, Line Cord	21955	21955
22.	Video Disc Player	23047	23047
23.	Video Disc	24058	24058
24.	Video Disc Carton (Mailer)	23663	23663
25.	Video Disc Clamp	23688	23552
26.	Filter Assembly	23516	23516
27.	Rear Door Lock	MH-0	MH-0
28.	Anchor Plate, Lock	MH-1	MH-1
29.	Fan (2)	23490	23490
30.	Plastic Grill (2)	23307	23307
31.	Latch (3)	21969	21969
32.	Latch Plate (3)	23234	23234
33.	Slam Switch and Bracket (Front)	23791	23791
34.	Slam Switch and Bracket (Side)	23703	23703

CABINET PARTS (EXTERIOR)

ITEM	DESCRIPTION	PART NO.	
		UPRIGHT	SIT-DOWN
1.	Inside Left Decal	23658	23542
2.	Inside Right Decal	23659	23543
3.	Inside Rear Decal	23660	N/A
4.	Top Cabinet Decal	23695	23421
5.	Lexan Overlay	23696	N/A
6.	Left Side Decal	23925	23930
7.	Right Side Decal	23927	23931
8.	Front Cabinet Decal	N/A	23925
9.	Upper Front Cabinet Decal	N/A	23935
10.	Top Glass	22464	23381
11.	CRT Frame	23926	23933
12.	Monitor Filter Glass	22849	23382
13.	Monitor Mask	22463	23513
14.	Monitor Lens (Fresnel)	N/A	23305
14A.	Glass Seal	N/A	22000
15.	Monitor	21981	21981
16.	Window	N/A	23383
17.	Marquee	23928	N/A
18.	Speaker	EL-83	EL-83
19.	Speaker Grill	20931	20931
20.	Floor Mat	N/A	23411
21.	Interlock Switch	EL-66	EL-66
22.	Cover, Interlock Switch	21888	21888
23.	Leg Adjuster	MH-21	MH-22
24.	Caster	N/A	23487
25.	On-Off Switch	23799	23799
26.	Switch Plate	18769	18769
27.	Vent Channel	21754	21754

FILTER BOARD I

REFERENCE	DESCRIPTION	PART NO.
	Filter Board #1 Assy.	MA-457
A8P1	6 Pin Wafer Conn.	XO-373
A8P2	9 Pin Wafer Conn.	XO-375
A8P3	10 Pin Wafer Conn.	XO-336
A8P4	8 Pin Wafer Conn.	XO-339
A8P5	7 Pin Wafer Conn.	XO-335
A8P6	4 Pin Wafer Conn.	XO-369
A8P7	7 Pin Wafer Conn.	XO-335
A8P8	6 Pin Wafer Conn.	XO-373
A8P9	9 Pin Wafer Conn.	XO-375
A8P10	10 Pin Wafer Conn.	XO-336
A8P11	8 Pin Wafer Conn.	XO-339
A8P12	7 Pin Wafer Conn.	XO-335
A8P13	4 Pin Wafer Conn.	XO-369
A8P14	7 Pin Wafer Conn.	XO-335
	Capacitor, .01UF, 50V CM-AX, +80%-20% (38 each)	XO-229
	Capacitor, 39PF, 50V CM-AX (6 each)	XO-334
	Ferrite Bead (22 each)	XO-337
	Ferrite Bead (66 each)	XO-338

FILTER BOARD II

REFERENCE	DESCRIPTION	PART NO.
	RF Filter Assembly	MA-530
	Capacitor, 39PF, 50V, CM-AX	XO-334
	Capacitor, .001UF, 50V, CM-AX	XO-695
	Ferrite Bead	XO-338
J17-J24	Jack, Phono	XO-744

NOTE: FILTER BOARDS ARE THE SAME IN BOTH VERSIONS.

SERVICE NOTES

LIMITED WARRANTY

Mylstar Electronics, Inc. warrants to the initial purchaser of the Mylstar Electronics, Inc. machine that the items listed in the following schedule as installed and used in the original Mylstar Electronics, Inc. machine will for the applicable period set forth in the schedule, computed from the initial date of purchase from an authorized Mylstar Electronics, Inc. distributor, be free of defects in materials and workmanship:

SCHEDULE

<u>GAME</u>	<u>ITEM</u>	<u>WARRANTY PERIOD</u>
Pinball	All Electronic Printed circuit boards	90 days
Pinball-Video	All Electronic Printed Circuit Boards	90 days
	Card Cage	90 days
	Television Monitor	30 days
Video	All Electronic Printed Circuit Boards	90 days
	Television Monitor	30 days
Video Disc	Video Disc Player	60 days

This Limited Warranty does not apply to any parts damaged in the course of handling or assembling by the customer or damage due to other than normal use or use in violation of instructions or reasonable practices, or further damaged in return shipment. This Limited Warranty is made only to the original customer, and is and shall be in lieu of all other warranties expressed or implied, and of all other obligations or liabilities on the part of Mylstar Electronics, Inc. and in no event shall Mylstar Electronics, Inc. be liable for any anticipated profits, consequential damages, loss of time, or other losses incurred by the customer in connection with the purchase or operation of Mylstar Electronics, Inc. machines or components thereof.

The registration card with each Mylstar Electronics, Inc. factory-wired machine must be filled in and returned to Mylstar Electronics, Inc. within ten days after date of purchase for this Limited Warranty to be effective. This Limited Warranty applies only to machines so registered.

THIS LIMITED WARRANTY IS IN LIEU OF ANY OTHER EXPRESS OR IMPLIED WARRANTIES, INCLUDING ANY IMPLIED WARRANTY OF MERCHANTABILITY OR FITNESS, AND OF ANY OTHER OBLIGATION ON THE PART OF THE SELLER AND MYLSTAR ELECTRONICS, INC.



**MYLSTAR
ELECTRONICS
INC.**



MYLSTAR ELECTRONICS, INC.
165 West Lake Street
Northlake, Illinois 60164
Tel (312) 562-7400
Telex 72-8463
A Columbia Pictures
Industries Company

