

September 1990
16-40003A-101

MIDWAY

TM



OPERATIONS MANUAL

ONE to FOUR PLAYERS



MIDWAY MANUFACTURING COMPANY

TROG

The Legend of

TROG™

IN PLAYmation!™

Long, long ago,
In a land named OG-
There lived a One-eyed Caveman
by the name of TROG I

And in that land
There lived four friends-
REX and BLOOP,
SPIKE and GWEN I

They need your help
to get home you see-
For if you don't lead them
TROG'S **DINNER** they'll be I

TROG is always thinking,
Inventing something new-
The wheel and the club
and the bouncing spring shoe I

When they've picked up all their
eggs,
You'll see them smile and shout-
`Cause leading Dinos **HOME**
Is what the game's about I

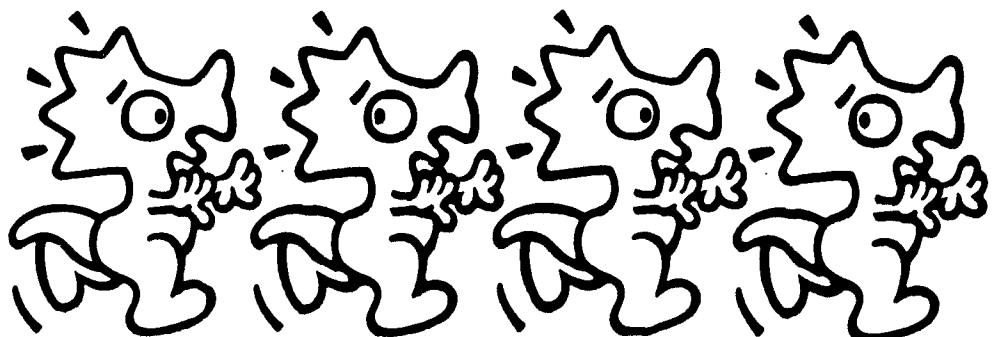

TABLE OF CONTENTS

Section 1 Operation and Troubleshooting

Safety	1-2
Set-up Procedure	
Installation & Inspection.....	1-3
Location Requirements.....	1-3
Cabinet Assembly Diagram.....	1-4
Servicing	1-5
Game Features	
Starting-up.....	1-7
Player Controls.....	1-7
Control Panel Diagram.....	1-7
Game Operation	
Control Switches.....	1-8
Control Switch Location Diagram.....	1-8
Game Adjustment & Diagnostics	
Starting-up.....	1-9
Main Test Menu.....	1-9
Diagnostic Tests.....	1-10
Switch Test.....	1-10
DIP Switch Test & Chart.....	1-11
CPU & Sound Tests.....	1-12
Monitor Patterns & Burn-In Tests.....	1-13
Coin Bookkeeping.....	1-14
Game Audits.....	1-14
Game Adjustments.....	1-16
Standard Pricing Chart.....	1-19
Utilities.....	1-20
Troubleshooting	1-21

Section 2 Parts Information

Cabinet, Speaker, & Lamp Parts.....	2-2
PC Boards, Transformer, Control Panel, & Monitor.....	2-3
Cables, & Manuals.....	2-4
Audio Board.....	2-5
CPU Board.....	2-6
Power Supply.....	2-8

Section 3 Diagrams and Schematics

JAMMA Edge Connector Chart.....	3-2
Audio Board Layout.....	3-3
Audio Board Schematic.....	3-4
CPU Diagram.....	3-5
CPU Schematic.....	3-6
Cabinet Wiring Diagram.....	3-22
Control Panel Diagram.....	3-23
Power Wiring Diagram.....	3-24
Interboard Wiring Diagram.....	3-25
Control Panel Wire Colors.....	3-26

RULES

Up to four people can play simultaneously.

Each person chooses their own DINO, Rex, Bloop, Spike, or Gwen.

Use the joystick to move the DINO.

Press the PUNCH Button to make the DINO PUNCH.

Pick up a HOT CHILI PEPPER and press the PUNCH Button to make the DINO FIRE.

Pick up all of your DINOS EGGS to reveal HOME.

The first DINO HOME WINS.

Keep DINOS away from DANGEROUS areas, like the EDGE OF THE WATER and THE PITS.

Especially, keep DINOS away from TROG.

TROG

S E C T I O N
one

Operation and Troubleshooting

Safety Notices

The following safety hints apply to all game operators and service personnel. Specific warnings and cautions will be found throughout this manual where they apply. We recommend that you read this page, and also all of Section 1, before preparing your game for play.

WARNINGS

AC POWER CONNECTION. Before connecting the game to the AC power source, verify that the "line voltage selection chart" jumper wires are installed correctly for the line voltage in your area. For details, refer to Section 3.

PROPERLY GROUND THE GAME. To avoid electrical shocks, do not plug in the game until it has been inspected and properly grounded. Midway games should only be plugged into a grounded 3-wire outlet. Shocks will also result, if the control panel is not properly grounded! After servicing any parts on the panel, assure that the ground wires are secure. Only then should you lock up the game.

DISCONNECT POWER DURING REPAIRS. To avoid electrical shock, disconnect the game from the AC power source before removing or repairing any part of the game. When removing or repairing the monitor, extra precautions must be taken to avoid electrical shock because high voltages may exist within the monitor circuitry and cathode ray tube (crt) even after power has been disconnected. Do not touch internal parts of the display with your hands or metal objects! Always discharge the crt: attach one end of a large, well-insulated, 20-kV jumper to ground. Momentarily touch the free end of the grounded jumper to the anode by sliding it under the anode cap. Wait two minutes and discharge the anode again.

USE THE PROPER FUSE. To avoid electrical shock, use the replacement fuse which is specified in the parts list for this game. The replacement fuse must match the original fuse in fuse type, voltage rating, and current rating.

HANDLE FLUORESCENT TUBE AND CRT WITH CARE. If you drop a fluorescent tube or CRT and it breaks, it will implode! Shattered glass can fly eight feet or more from the implosion.

CAUTION

PROPERLY ATTACH ALL CONNECTORS. Make sure that the connectors on each printed circuit board (pcb) are properly connected. If they do not slip on easily, do not force them. A reversed connector may damage your game and void the warranty. All connectors are keyed to fit specific pins on each board.

Setup Procedure

Installation and Inspection

1. Remove the game from its shipping carton, and inspect the exterior of the cabinet for any signs of damage. Remove the shipping cleats from the bottom of the cabinet.
2. Remove keys from the taped coin return slot (or attached to joystick). Unlock and open the coin and cash box doors. (Leg levellers and spare parts are stored in the cash box.)
3. Locate the four threaded holes on the bottom of the cabinet (one in each corner), and install one leg leveller (with its hex nut) in each hole.
4. Stand the cabinet upright and make certain that it is in a stable position. Level the cabinet.
5. Unscrew (or unlock) and remove the rear doors/panels of the cabinet. Inspect the interior for any signs of damage. Check all major assemblies to assure that they are mounted securely.
6. Refer to the game's cabinet wiring diagram (Section 3), and check to see that all cable connectors are correctly secured and firmly seated. DO NOT FORCE CONNECTORS. Watch for damaged connectors and avoid making reversed connections.
7. Line Voltage Selection. Your game is designed to work properly on the line voltage where you are located. Determine the value of your line voltage with a meter. Then, check the power input wires to the main power supply transformer on your game to be sure they are connected to taps which correspond to your local line voltage value. If necessary, reconnect the power input wires to the transformer in accordance with the Transformer Chart in Section 3.

If the line voltage in your area falls outside the upper or lower limits of the range of voltage inputs covered by the main power supply transformer, DO NOT PLUG YOUR GAME IN until you have contacted your distributor or the Midway Service Department and obtained a solution to the problem. Otherwise, you could damage your game.
8. Lay the line cord (connected to the Power Chassis) in the slot along the bottom edge of the lower rear cabinet door/panel. Install the rear cabinet doors/panels and screw (lock) them securely. Close and lock the front coin and cash box doors.
9. Connect the line cord to a grounded (3-terminal) AC wall outlet.
10. Switch ON the game, using the ON/OFF switch located on the upper left rear of the cabinet, to verify proper operation.

GAME LOCATION REQUIREMENTS

Power

Domestic 115V @ 60 Hz
Foreign 230V @ 50 Hz

Temp.

32° F to 100° F
(0° C to 38° C)

Humidity

Not to exceed 95% relative.

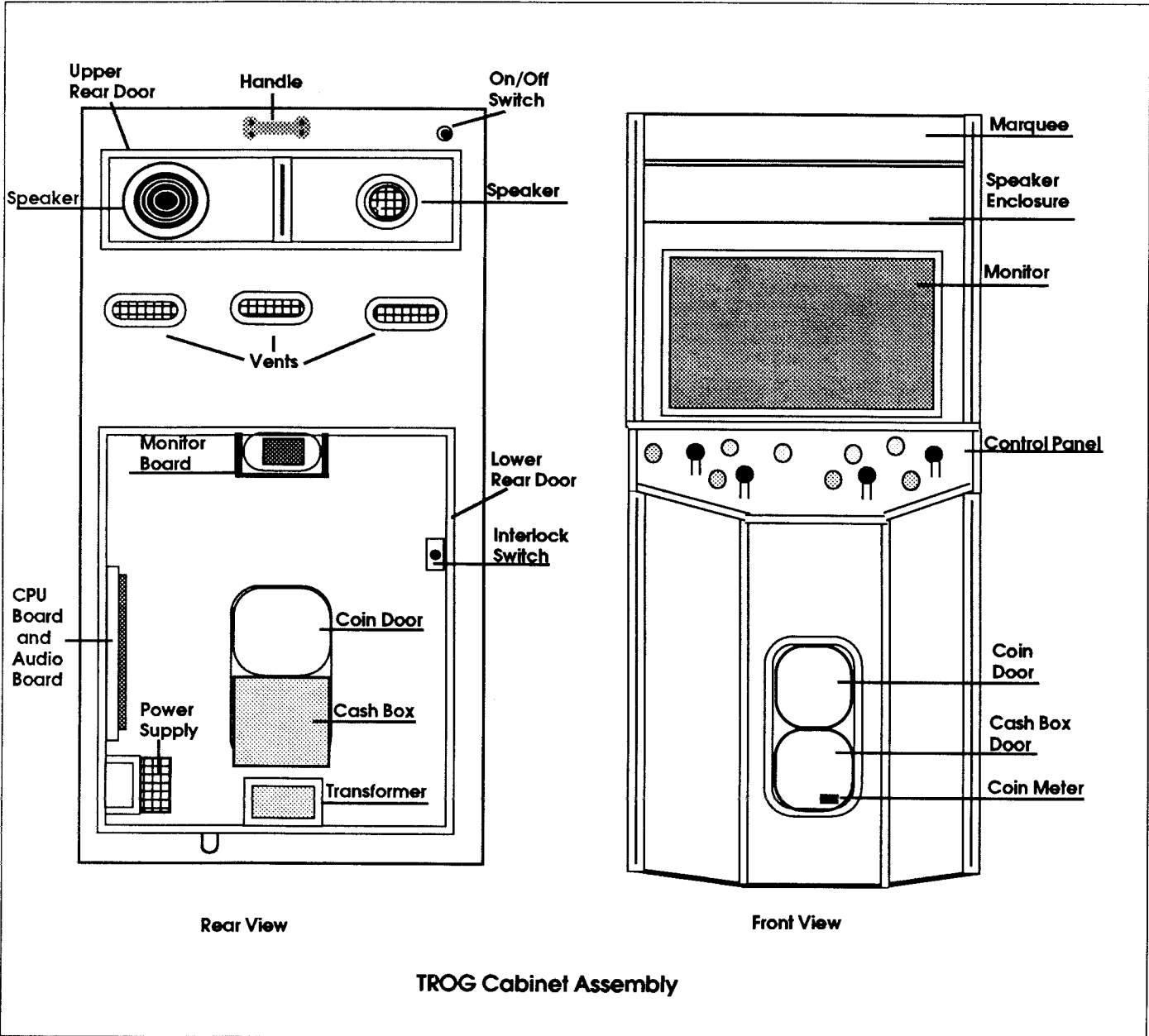

Servicing

■ Servicing the Control Panel

Switch OFF power to the game. The control panel is held in place by four latches (located on the left and right sides of the cabinet) which provide constant pressure on the strikes. The latches can be reached through the coin door opening. To release the latches, lift the latch handle and unhook the wire fasteners. Carefully use the joysticks to lift the control panel. Rest the panel on its support bracket, while working on it. To reinstall the control panel, check for proper cable connections, including the ground strap, and use the joysticks to lower it into position, avoiding pinched wires. Reclamp the latches.

NOTE

To remove the control panel for bench servicing, release the latches and lift the control panel, until it rests on its support bracket. Disconnect the cables and the ground strap. Lift the control panel out of the game cabinet.

CAUTION

To preserve color purity of the monitor, when moving the game be sure the power is turned OFF.

■ Removal of Viewing Glass

Switch OFF power to the game, and open the control panel. Unscrew the four nuts at the bottom of the glass and remove the protective black plastic strip. Carefully lift the glass from its bottom groove and lift it clear of the cabinet.

CAUTION

The monitor *DOES NOT* contain an isolation transformer in its chassis (it is mounted instead in the Power Chassis Assembly located on the floor of the cabinet). When servicing the monitor on a test bench, **YOU MUST ISOLATE THE MONITOR FROM THE LINE VOLTAGE WITH AN ISOLATION TRANSFORMER.**

■ Removal of Monitor Bezel

Switch OFF power to the game, and remove the viewing glass. Remove the bezel securing screws to free the monitor bezel.

■ Monitor Replacement

We recommend that you read the WARNINGS section thoroughly before beginning this procedure.

Switch OFF power to the game. Open the upper rear door/panel. Remove the viewing glass and the monitor bezel. Completely disconnect the monitor from all of its cabling, including its chassis ground strap. Remove the four bolts securing the monitor's mounting flanges to its mounting panel. Pull the monitor carefully from the cabinet front.

CAUTION

While removing the four bolts, firmly support the monitor from the front of the CRT so that it will not slip.

WARNING

If you drop a fluorescent tube and it breaks, it will implode! Use care in handling.

■ Removal of the Marquee Glass

Switch OFF power to the game. Remove the screws in the black plastic strip on top of the cabinet. Remove the strip and carefully lift the glass. Store the glass carefully to prevent damage.

The fluorescent tube is now accessible for replacement. Grasp the tube, give it a quarter turn, and remove it from its socket. Carefully place a new tube into the socket, and turn to reinstall.

■ Removal of the Fluorescent Light Assembly

Switch OFF power to the game. Remove the marquee glass. Disconnect the fluorescent light assembly from its power cable. Remove the screws fastening the assembly to the cabinet and lift out the assembly.

■ Removal of the Speakers

Switch OFF power to the game. Remove the upper rear cabinet door/panel, taking care to *not* damage the speaker enclosure seals. Disconnect the speakers from their cabling. Remove the nuts on the speaker mounting bolts. Remove the speakers. Because the speakers are mounted in an acoustical enclosure, carefully reinstall the seals upon completing any task in the speaker enclosure.

■ Volume Control, Test/Diagnostics Switch, and Service Credit Switch

Open the coin door to locate the game's volume control and Diagnostic switches on the small panel atop the cash box cover. The Volume Control is the white knob on left end of the panel. Turning the knob clockwise increases the volume. The upper right switch on the bracket is the Test/Diagnostics Switch that enables activating the game's test mode. The lower right switch is the Service Credit Switch, which allows adding credits to a game for service testing without affecting the game's bookkeeping total.

Game Features

Starting Up

Switch ON power to the game. A 'rug' pattern appears on the CRT screen. When the 'rug' pattern ends, the screen shows CHECKING SCRATCH RAMS, and then CHECKING ROMS. The next screen shows TROG REVISION LEVEL, CMOS TEST OK and the COIN SETTING. The game then moves to the attract mode. After the proper coinage has been inserted, the game exits the attract mode and enters the play mode.

TROG is a one- to-four player game. Each player chooses his/her own DINO. Any combination of DINOS can be played simultaneously.

Player Controls

- Each **START** button allows the player to choose a Dino. BLOOP (blue); GWEN (purple); SPIKE (yellow); and REX (red).
- Each **PUNCH** button allows the player to either Punch or Fire. Press Punch to make your Dino punch. Pick up a HOT CHILI PEPPER and press Punch to make your Dino Fire.
- Each **JOYSTICK** allows each player to move their Dino up, down, left, or right.

NOTE

TROG will operate in the Test Mode, when the Test Switch (on the cash box cover) is closed or DIP Switch Bank #2 Switch #8 is closed.

When an error is detected during Start-up Tests, game start-up does not progress, and an error message appears on the screen.

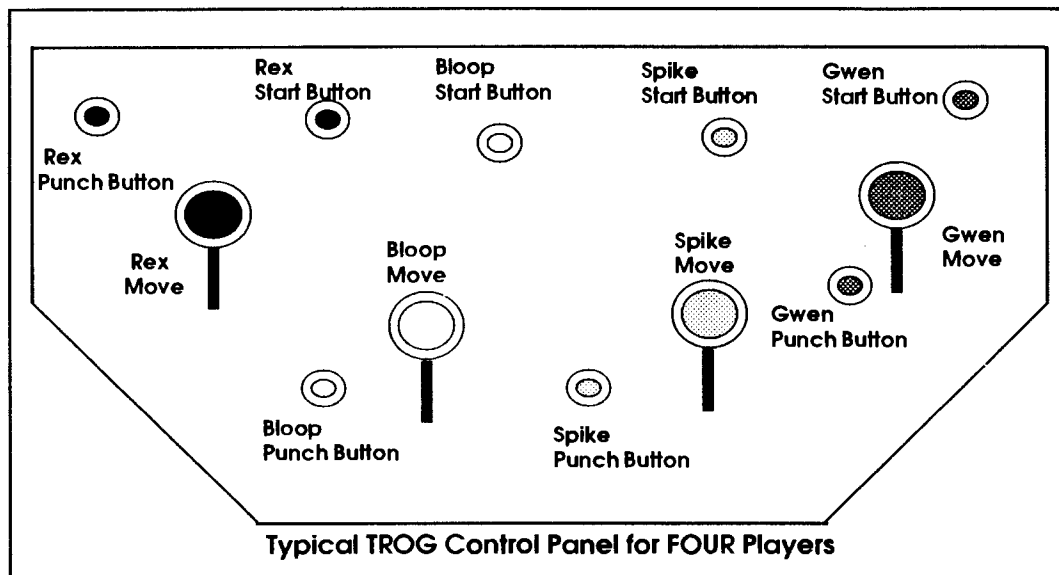

Game Operation

TROG is a one- to four-player video game with a color monitor. From the player's perspective, the game has two modes of operation: Ready-to-Play and Play. For the owner/operator, the game has an additional mode of operation called Game Audit, Adjustments and Diagnostics.

Control Switches

- The **VOLUME CONTROL** allows increasing or decreasing the volume level of the game music and speech. For greater profits, set your game's volume level at its maximum.
- The **TEST/DIAGNOSTICS SWITCH** allows you to enter into the game's Diagnostic mode. Turn the Test Switch ON to enter the Diagnostics mode. To exit this mode, turn the Test Switch OFF. Game diagnostics can be reached via the DIP Switches also.
- The **SERVICE CREDIT SWITCH** is a special feature switch that allots credit without affecting the game's book-keeping total.
- The **COIN DOOR SLAM TILT SWITCH** detects any forceful vibrations against the Coin Door. This eliminates pounding for free games.
- The **POWER INTERLOCK SWITCH** is a safety switch that ensures power to the game is off during servicing. This switch is located inside the rear door/panel.

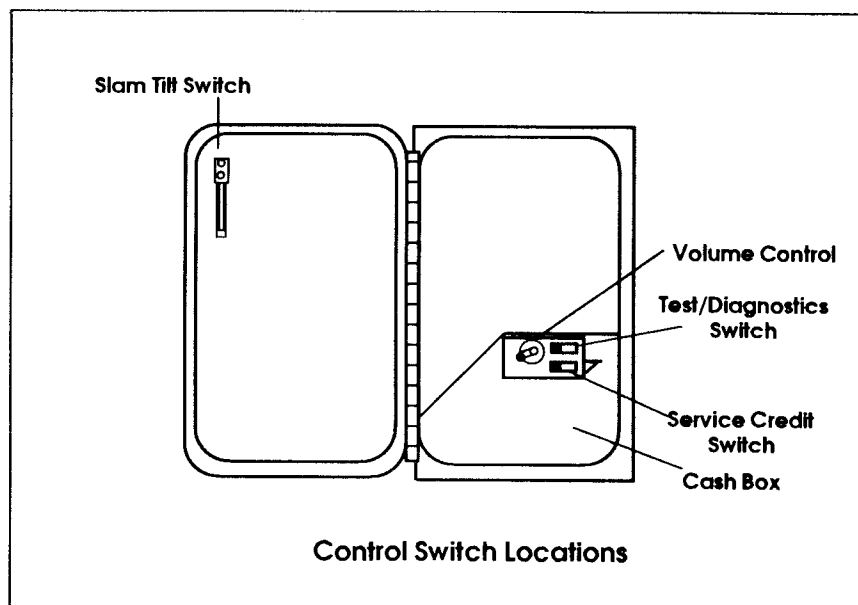

Game Audits, Adjustments & Diagnostics

Operation

All TROG Game Audits, Adjustments, and Diagnostics are options of the Main Test Menu. Each option, in turn, has its own menu, listing several choices that you may act upon as desired.

To enter the Main Menu, turn ON the Test Switch (on the cash box cover), or turn ON DIP Switch #8 in switch bank 2. The Main Test Menu (shown below) then appears. Game adjustments, bookkeeping, and diagnostics are all accessible from this menu.

Move any joystick up or down to cycle through the menu options. Notice that the options are highlighted in sequence. Selecting a desired option requires it to be highlighted. To activate the selected option, press any control panel button.

To exit, use any joystick to highlight Exit To Game Over and turn OFF either the Test Switch or DIP Switch #8 in switch bank 2.

The Main Test Menu lists six options.

**SELECT WITH UP/DOWN STICK
ACTIVATE WITH ANY BUTTON**

**DIAGNOSTIC TESTS
COIN BOOKKEEPING
GAME AUDITS
GAME ADJUSTMENTS
UTILITIES
EXIT TO GAME OVER**

Main Test Menu

DIAGNOSTIC TESTS

To enter the Diagnostic Tests from the Main Test Menu, move any joystick to select (highlight) the Diagnostic Tests option, and press any control panel button to activate the option.

The Diagnostic Tests Menu lists seven options.

**SELECT WITH UP/DOWN STICK
ACTIVATE WITH ANY BUTTON.**

SWITCH TEST

DIP SWITCH TEST

CPU BOARD TEST

SOUND BOARD TEST

MONITOR PATTERNS

BURN-IN TEST

RETURN TO MAIN MENU

Diagnostic Test Menu

Switch Test

The Switch Test allows the operator to test the switches on the control panel and the coin door.

Select the Switch Test by using any joystick to highlight the Switch Test option; then, press any control panel button to activate it. The screen shows the control panel and coin door switches. Pressing a switch causes the corresponding switch location on the screen to light. Release the switch and the screen returns to normal.

Press both Player 1 Punch and Player 1 Start Buttons to return to the Diagnostic Menu.

DIP Switch Test

The DIP Switch Test allows the operator to check the position of the two 8-position DIP switches on the CPU Board. The operator can also change the setting of each position of each DIP switch during this mode.

Select the DIP Switch Test by moving any joystick to highlight the DIP Switch Test option; then, press any control panel button to activate the test. The screen displays a layout of the DIP switches and their current settings.

To change the setting of either DIP switch, press the switch position (SW1 - SW8) to the desired setting (ON from OFF, or vice versa). Check the screen to verify that the switch now shows the setting desired.

Press any control panel button to return to the Diagnostic Test Menu.

DIP Switch 1 Settings Table

	SW 1	SW 2	SW 3	SW 4	SW 5	SW 6	SW 7	SW 8
Upright Midway Cocktail	Off * On							
CMOS Coinage DIP Switch Coinage		On Off *						
Coin Settings								
USA 1	Ger 1	Fr 1	Off *	Off *	Off *			
USA 2	Ger 2	Fr 2	On	Off	Off			
USA 3	Ger 3	Fr 3	Off	On	Off			
USA 4	Ger 4	Fr 4	On	On	Off			
USA ECA	Ger ECA	Fr ECA	Off	Off	On			
N/U	N/U	N/U	On	Off	On			
N/U	N/U	N/U	Off	On	On			
Free Play	Free Play	Free Play	On	On	On			
Not Used						Off *	Off *	Off *

DIP Switch 2 Settings Table

	SW1	SW2	SW3	SW4	SW5	SW6	SW7	SW8
USA	Off *	Off *						
German	On	Off						
French	Off	On						
Not Used	On	On						
Not Used			Off *					
One Counter Two Counters				Off * On				
4 Players					Off *	Off *		
3 Players					On	Off		
2 Players					Off	On		
1 Player					On	On		
Video Freeze (activates when change detected)							Off * On	
Test Switch Game Mode Test Mode								Off * On

* Indicates Factory Setting

NOTE

As soon as a faulty chip is detected, the CPU Test stops. The remaining chips are not tested.

CPU Board Test

The CPU Board Test (much like the Start-up Test) allows the operator to check the RAMs and ROMs.

Move any joystick to select the CPU Board Test; then, press any control panel button to activate the automatic test of the CPU Board's RAMs and ROMs. When this test is activated, a "rug" pattern appears on the screen. The screen then changes to show the layout of the RAMs, and ROMs on the CPU. Any chip that is shown as black with a white outline is part of the CPU and should turn either red or green during the CPU Test. Any chip that is shown as gray with a white outline is not installed in the game. During the test, chips are good, if they turn green; they are faulty, if they turn red.

If no errors are detected, the screen automatically returns to the Diagnostic Menu.

Sound Board Test

The Sound Test allows listening to some of the sounds that TROG is capable of producing. This test also emits a tone for each fault that is detected.

Move any joystick to select the Sound Board Test; then, press any control panel button to activate the test. The screen displays two test options:

GENERAL TEST analyzes the sound circuitry. A successful test causes a single "tone" to sound. Detection of a fault causes a series of tones, or no tone at all to sound.

PLAY SOUNDS tests synthesized sounds from the Sound Board. Press any Punch Button to advance to the next sound.

To exit this test, use any joystick to select Back to Diagnostic Menu, or Return to Main Menu; then press any control panel button.

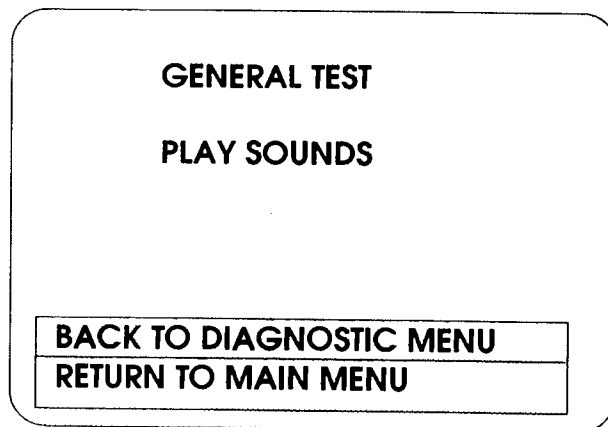

Sound Test Menu

Monitor Patterns

The Monitor Patterns Test provides a menu for testing the monitor.

Move any joystick to select a test; press any control panel button to activate the test.

**SELECT WITH UP/DOWN STICK
ACTIVATE WITH ANY BUTTON.**

RED SCREEN

GREEN SCREEN

BLUE SCREEN

COLOR BARS

CROSSHATCH PATTERNS

BACK TO DIAGNOSTIC MENU

RETURN TO MAIN MENU

Monitor Pattern Menu

The **RED**, **GREEN**, and **BLUE SCREEN** tests fill the screen with either red, green or blue.

The **COLOR BARS** test fills the screen with several gradated colors to help with red, green and, blue level adjustments. Each color should appear sharp and clear.

The **CROSSHATCH PATTERNS** test fills the screen with a grid and a series of dots. The grid and the dots should be clear. The dots should appear round.

Exit this test by pressing any control panel button to return to the Monitor Patterns Menu. Use any joystick to select Back to Diagnostic Menu, or Return to Main Menu; then press any control panel button.

NOTE

TROG provides front-mounted Monitor Board controls. These controls are accessible within the control panel opening beneath the monitor.

Burn-in Test

The Burn-in Test continually repeats the CPU Board Test. Move any joystick to select the Burn-In Test; then, press any button to activate the test. When the Burn-in Test detects an error, the test stops and displays an error message on the screen. The third page of the Audit Table specifies the number of Burn-in cycles successfully completed. Use this test to find intermittent CPU problems.

To exit this test, switch OFF the game; then, switch it ON again.

COIN BOOKKEEPING

To enter the Coin Bookkeeping from the Main Test Menu, move any joystick to select the Coin Bookkeeping option; then, press any control panel button to activate it.

The Coin Bookkeeping Table records the coinbox totals and game play counters. The left side of the table names the bookkeeping item; the right side shows the number of coins, credits, or plays for each item.

LEFT SLOT COIN	0
RIGHT SLOT COIN	0
THIRD SLOT COIN	0
FOURTH SLOT COIN	0
SERVICE CREDITS	0
PAID CREDITS	0
GAMES STARTED	0
GAMES CONTINUED	0
TOTAL PLAYS	0
PLAYS UNTIL HIGH SCORE RESET	5000

MORE DETAILED INFORMATION

RETURN TO MAIN MENU

Coin Bookkeeping Table

To exit Coin Bookkeeping, move any joystick to select RETURN TO MAIN MENU; then, press any control panel button to activate it.

GAME AUDITS

To enter Game Audits from the Main Test Menu, move any joystick to select the Game Audits option; then, press any button to activate it. To advance to the next (or return to the previous) page of the Game Audit Table, move any joystick to select either "Next Audit Page", or "Previous Audit Page"; then, press any control panel button to change the page.

The Game Audits Table records the game play statistics. The left side of the table names the Audit item; the right side shows the amount of play.

TOTAL PLAYS	0
TOTAL PLAY TIME	0
TOTAL GAME UP TIME	0
AVERAGE TIME/LIFE	0
AVERAGE TIME/CREDIT	0
TIME 1 PLAYER ONLY	0
TIME 2 PLAYERS SIMULTANEOUS	0
TIME 3 PLAYERS SIMULTANEOUS	0
TIME 4 PLAYERS SIMULTANEOUS	0
NEXT AUDIT PAGE	
RETURN TO MAIN MENU	

PAGE 1 OF AUDIT TABLE

TOTAL PLAYS	0
AVERAGE CREDITS/GAME	0
BEGINNER STARTS	0
ADVANCED STARTS	0
EXPERT STARTS	0
AVERAGE WAVE REACHED	0
GAMES PLAYED TO COMPLETION	0
MAXIMUM WAVE COMPLETED	0
NEXT AUDIT PAGE	
PREVIOUS AUDIT PAGE	
RETURN TO MAIN MENU	

PAGE 2 OF AUDIT TABLE

TOTAL EXTRA DINOS EARNED	0
GAME CONTINUES OFFERED	0
GAME CONTINUES TAKEN	0
PERCENTAGE OF CONTINUES TAKEN	0
COIN DOOR SLAMS	0
BURN-IN LOOPS SUCCESSFULLY COMPLETED	0
PREVIOUS AUDIT PAGE	
RETURN TO MAIN MENU	

PAGE 3 OF AUDIT TABLE

To exit the Game Audit Table , move any Joystick to select RETURN TO MAIN MENU; then, press any control panel button to activate it.

GAME ADJUSTMENTS

Move any joystick to select the Game Adjustment option on the Main Test Menu; then, press any control panel button to activate it.

The Game Adjustments option allows the owner/operator to change the Game Pricing and Game Difficulty.

The Game Adjustment Menu offers 12 choices. Several of these choices have their own menu. Move any joystick to select your choice from the Game Adjustments Menu; then, press any control panel button to activate that choice. On the next menu, either move any joystick to select the item you wish to modify; then, press any control panel button to activate that item, or if the item only provides a setting choice, move any joystick to change the current setting to the desired value; then, press any control panel button to lock in the desired value. Moving the joystick up increases the setting value shown on the screen. Moving the joystick down causes the value shown on the screen to decrease.

**SELECT WITH UP/DOWN STICK
PRESS ANY BUTTON TO MODIFY**

RETURN TO MAIN MENU

STANDARD PRICING

CUSTOM PRICING

GAME DIFFICULTY

LIVES PER PLAY

EXTRA MAN EVERY

NUMBER OF EXTRA MEN

AUTO HIGH SCORE RESET

FREE PLAY

HIGH SCORE ENTRY

ALLOW GAME CONTINUE

RETURN TO MAIN MENU

Game Adjustment Menu

Standard Pricing

Standard Pricing allows the operator to choose any of the "Standard" selections for the Standard Pricing Table. Standard Pricing *cannot* be installed when either Custom or DIP Switch Pricing is in effect.

Press any control panel button to lock in the selected setting and return to the Game Adjustments Menu.

Custom Pricing

Custom Pricing allows the operator to install pricing other than that of the Standard Pricing Table. Custom Pricing also allows the operator to select the maximum amount of credits per game, the amount of credits required to start a game, and the amount of credits required to continue a game. Custom Pricing *cannot* be installed when DIP Switch Pricing is in effect.

Press any control panel button to lock in the selected setting and return to the Game Adjustments Menu.

Game Difficulty

Game Difficulty allows the operator to select the difficulty level of the game. The range of this setting is Easiest (1) to Hardest (10).

Press any control panel button to lock in the selected setting and return to the Game Adjustments Menu.

Lives per Play

Lives per Play allows the operator to select the number of lives a player receives each time a game is started or continued.

Press any control panel button to lock in the selected setting and return to the Game Adjustments Menu.

Extra Man Every

Extra Man Every allows the operator determine how many points the player must earn before receiving an extra life.

Press any control panel button to lock in the selected setting and return to the Game Adjustments Menu.

Number of Extra Men

Number of Extra Men allows the operator to determine how many men the player can earn per credit.

Press any control panel button to lock in the selected setting and return to the Game Adjustments Menu.

NOTE

The TROG Standard Pricing Table is on page 1-19.

Auto High Score Reset

Auto High Score Reset allows the operator to determine how many plays must occur before the all time high scores are automatically reset to factory settings.

Press any control panel button to lock in the selected setting and return to the Game Adjustments Menu.

Free Play

Free Play allows the operator to determine whether game play can occur without any coins being dropped into the coin chutes. Free Play *cannot* be installed when DIP Switch Pricing is in effect.

Press any control panel button to lock in the selected setting and return to the Game Adjustments Menu.

High Score Entry

Allows the operator to determine whether the game has a High Score Entry Table and Display.

Press any control panel button to lock in the selected setting and return to the Game Adjustments Menu.

Allow Game Continue

Allow Game Continue allows the operator to determine whether a player can continue to play even though all other players are dead.

Press any control panel button to lock in the selected setting and return to the Game Adjustments Menu.

To return to the Main Test Menu, move any joystick to select RETURN TO MAIN MENU; then, press any control panel button to activate the return.

TROG Standard Pricing Table

NAME	SETTING Credit/Coin	LEFT CHUTE	CENTER CHUTE	RIGHT CHUTE	FOURTH CHUTE
USA 1	1/25¢	25¢		25¢	
USA 2	1/50¢	25¢		25¢	
USA 3	1/50¢, 3/\$1.00	25¢		25¢	
USA 4	1/50¢, 4/\$1.00	25¢		25¢	
USA ECA	1/25¢, 4/\$1.00	\$ 1.00	10¢	25¢	5¢
German 1	1/1 DM, 6/5 DM	1 DM		5 DM	
German 2	1/1 DM, 7/5 DM	1 DM		5 DM	
German 3	1/1 DM, 8/5 DM	1 DM		5 DM	
German 4	1/1 DM, 5/5 DM	1 DM		5 DM	
German ECA	1/1 DM, 2/2 DM, 6/5 DM	5DM	1DM	2DM	
France 1	2/5 F, 5/10 F	5 F		10 F	
France 2	2/5 F, 4/10 F	5 F		10 F	
France 3	1/5 F, 3/10 F	5 F		10 F	
France 4	1/5 F, 2/10 F	5 F		10 F	
France ECA	1/3 X 1 F, 2/5 F, 5/2 X 5 F	1F	10F	5F	
Swiss	1/1 F, 6/5 F	1 F		5 F	
Italy	1/500 Lire	500 Lire		500 Lire	
UK 1	1/20 P, 3/50 P	20 P		50 P	
UK ECA	1/30 P, 2/50 P, 4/£1.00	£1.00	20P	50 P	10 P
Spain 1	1/25 Peseta, 5/100 Peseta	25 Peseta		100 Peseta	
Japan 1	1/100 Yen	100 Yen		100 Yen	

If option desired is not shown above, use custom pricing .

UTILITIES

On the MainTest Menu, move any joystick to select the Utilities option; then, press any control panel button to activate it.

The Utilities option allows the owner/operator to clear the game's bookkeeping memory and to install a custom message.

**SELECT WITH UP/DOWN STICK
ACTIVATE WITH ANY BUTTON**

OPERATOR MESSAGE

CLEAR CREDITS

CLEAR COIN COUNTERS

CLEAR GAME AUDITS

RESET HIGH SCORE

DEFAULT ADJUSTMENTS

FULL FACTORY RESTORE

RETURN TO MAIN MENU

Utilities Menu

Move any joystick to select an item from the Utilities Menu; then, press any control panel button to activate that item. After an item has been activated, you are given the option of resetting the item or not. For example;

CLEAR CREDITS ARE YOU SURE ?		
<table border="1"><tr><td>YES</td></tr><tr><td>NO</td></tr></table>	YES	NO
YES		
NO		

Move any joystick to choose YES or NO; then, press any control panel button to lock in your choice and to return to the Utilities Menu.

To exit Utilities, move any joystick to select RETURN TO MAIN MENU; then, press any control panel button to activate it.

Troubleshooting

Problem	Possible Solution
NO PICTURE OR DISTORTED PICTURE.	Check for faulty video board or monitor. Check for disconnected video signal cable.
TURN GAME ON & NOTHING HAPPENS	Check line fuse. Check for +5V dc at pins C, D, 3, and 4 of the JAMMA Connector.
NO SOUND	Check the speaker and speaker connection to pins L and 10 on JAMMA Connector. Check volume control setting. Check for +12V dc at pins F and 6 on the JAMMA Connector. Check interboard wiring from CPU Board to Sound Board.
NO GENERAL ILLUMINATION	Check the 1A., S-B fuse on the cabinet wall above the coin box.
MOVE JOYSTICK, BUT DINO DOES NOT MOVE	Check for open wires between Joystick and CPU Board. Check for contamination on joystick switch contacts and CPU Board pins. Check for proper ground.
PRESS START or PUNCH BUTTON AND NOTHING HAPPENS	Check for open wires between button and CPU Board. Check for contamination on CPU Board pins or button switch blade contacts. Check for proper ground.
NO CREDIT GIVEN WHEN COINS ARE INSERTED	Check DIP switch coin setting. Check for contamination on coin switch contacts. Check for an open wire between Coin Switch 1 and pin 16 on JAMMA Connector or Coin Switch 2 and pin T of JAMMA Connector.
TOO MANY CREDITS FOR NUMBER OF COINS INSERTED	Check Game Pricing setting. Check for a short between pins T & 16 on JAMMA Connector.
GAME STAYS IN THE TEST MODE.	Check that the Test Switch (on the cash box cover) and the Test Switch (Position 8) on DIP Switch 2 are set to OFF.

Notes

TROG

S E C T I O N

two

Parts Information

Cabinet Hardware

Cabinet Assembly	A-11-933-4005
Caster Wheel Assembly	B-13086
Leg Leveler Plate	01-9155
Leg Adjuster	08-7377
Back Door Assembly	B-13574
Lock Retainer	01-7264
Upper Door Lock Cam	01-8989
Rear Wood Door	11-934
Door Cam Lock	20-6542-TB
Line Voltage Cable Assembly	C-12773-4
Mtg Plt Toggle Assembly	A-9958
Interlock Spring Brkt. Assy	B-12907
Line Voltage Cable	H-13555
Protective Cap	17-1038-2
Toggle Switch	5640-10932-00
Interlock Cheat Switch	5643-09556-00
Over/Under Coin Door	D-13250
Test Switch	A-13115
Coin Door Cable	H-13215
Coin Door USA	09-20000-V-1
12 pin 'Z' Header	5791-12235-12
Glass Retainer Bracket	01-9607
20" Vent Hole Cover	03-7602
Vent Hole Cover	03-7839
Marquee Retainer	03-8252-2
Lock Lamp	03-8327
Glass Edge Channel	03-8358
25" CRT Bezel	03-8387
Vent Hole Cover	03-8413
Speaker Wood Door	11-935
Toggle Latch	20-9347
TROG Marquee	31-1543-4005-U
Glass CRT Cover	31-1544-4005-U
Speaker Grille	31-1553-4005-U

Speakers

Plezo Speaker Assembly	B-13587
6" Round Speaker, 4 ohm, 10W	5555-12015-00

Fluorescent Lamp

Fluorescent Housing & Bracket	C-12679
Housing Mounting Brkt	01-9146
Light Fixture	20-9590
18" Fluorescent Bulb, 15 W	24-8809

PC Boards

Y-Unit CPU Assembly	C-13234-40003
Power Supply Assembly	C-13253-1
Audio Sound Board Assembly	D-11581-40003

Transformer Assembly

Power Pack Assembly	D-13252
Line Cord Assembly	A-13340
Power Transformer	5610-12559
Power Pack Chassi Assy	C-13251
Power Pack Jumper Cable	H-13265
Line Filter Jumper Cable	H-13344
Transformer Jumper Cable	H-13378
Varistor, 130V, 10J	5017-09044-00
Line Filter, 5Amp	5102-08895-00

Control Panel

Control Panel Assembly	A-14174
Control Panel Plate Assembly	C-13473
Blue Button Assembly	C-9214-1
Purple Button Assembly	C-9214-22
Red Button Assembly	C-9214-4
Yellow Button Assembly	C-9214-23
Control Panel Cable	H-13556
Latch Bracket	01-6994
Latch Bracket	01-9605
Universal Switch Molding	03-7614
Wood Control Panel	11-942
5/8 Palnut	20-9222
Red Joystick	20-9662
Yellow Joystick	20-9662-4
Purple Joystick	20-9662-6
Blue Joystick	20-9662-8
Screened Overlay	31-5-40003

Monitor

Monitor 25"	5675-12621-00
-------------	---------------

Cables

Video Sound/Power Cable	H-10217-4
Speaker Cable	H-13213
Coin Door Cable	H-13215
Sound/Power Speaker Cable	H-13257
Volume Control Cable	H-13258-2
Power Pack Jumper Cable	H-13265
Line Filter Jumper Cable	H-13344
Transformer Jumper Cable	H-13378
Main Harness Cable	H-13554
Line Voltage Cable	H-13555
Control Panel Cable	H-13556
Piezo Speaker Cable	H-13557
Ground Jumper Cable	H-13953
20 pin Ribbon Cable	5795-10937-18

Manuals

Monitor Manual	16-3000-103
Instruction Manual	16-40003A-101

D-11581-40003 Audio Board Assembly

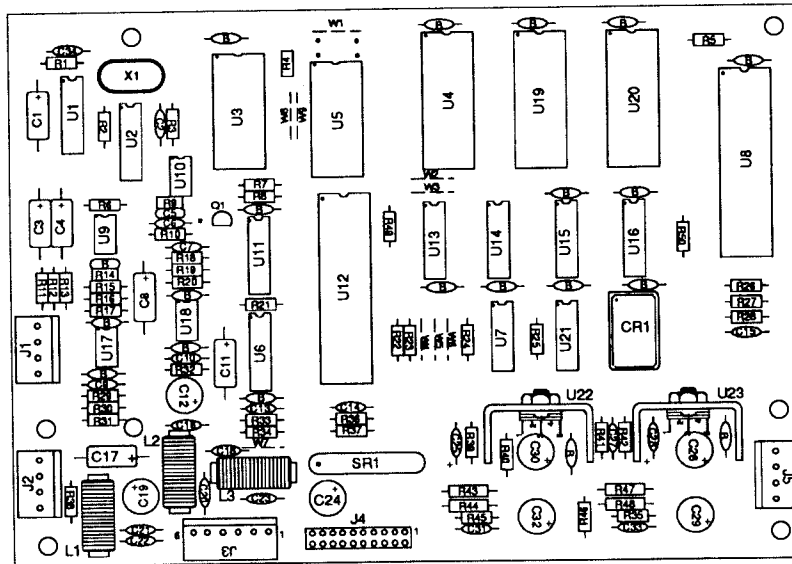

Part No.	Ckt Designator	Description	Part No.	Ckt Designator	Description
5766-12130-00		Bare P. C. Board	5010-10985-00	R14, R15	Resistor, 20K, 1/4w, 5%
5371-11067-00	U1	IC, D/A Conv, YM3012	5010-09034-00	R22-R24, R17, R34	Resistor, 10K, 1/4w, 5%
a) 5700-09006-00		Socket, IC, 16-pin (U1)	5010-09324-00	R6, R19, R20, R21	Resistor, 27K, 1/4w, 5%
5370-11086-00	U3	IC, Sound Processor, YM2151	5010-09162-00	R39	Resistor, 100K, 1/4w, 5%
a) 5700-09004-00		Socket, IC, 24-pin (U3)	5010-09331-00	R16	Resistor, 13K, 1/4W, 5%
5400-10320-00	U8	IC, μ Processor, MC68B09E	5010-08772-00	R18	Resistor, 15K Ω , 1/4W, 5%
a) 5700-08985-00		Socket, IC, 40-pin (U8)	5010-08824-00	R32	Resistor, 43K Ω , 1/4W, 5%
A-5343-40003-19	U4	IC, Audio ROM 1	5010-08846-00	R31	Resistor, 220K Ω , 1/4W, 5%
A-5343-40003-20	U19	IC, Audio ROM 2	5010-08981-00	R12	Resistor, 4.7K Ω , 1/4W, 5%
A-5343-40003-21	U20	IC, Audio ROM 3	5010-09219-00	R38	Resistor, 8.2K, 1/4W, 5%
a) 5700-10176-00		Socket, IC, 28-pin (U4, U19)	5010-10258-00	R40	Resistor, 1M, 1/4w, 5%
5371-09152-00	U11	IC, D/A Convr, MC1408	5010-09179-00	R10	Resistor, 3.3M, 1/4w, 5%
5430-10322-00	U12	IC, PIA, MC68B21	5010-09333-00	R29	Resistor, 180K Ω , 1/4W, 5%
5340-10139-00	U5	IC, RAM/S 5516-2 2Kx8	5010-09342-00	R30	Resistor, 36K Ω , 1/4W, 5%
5281-09487-00	U16	IC, Dual D Flipflop, 74LS74	5010-09534-00	W9	Resistor, 0 Ω , 1/4w, 5%
5281-10043-00	U13	IC, 74LS175	5040-09343-00	C1, C3, C4, C8	Capacitor, 10 μ fd, 20v, \pm 20%
5281-09235-00	U21	IC, Triple NAND, 74LS10	5040-10974-00	C12, C19, C24	Capacitor, 100 μ fd, 35v
5370-09321-00	U9, U10, U17, U18	IC, Op Amp, MC1458	5040-09776-00	C26, C30	Capacitor, 470 μ fd, 16v; +50, -10%
5281-09215-00	U2	IC, Hex Inv, 74LS04	5040-12008-00	C29, C32	Capacitor, 1000 μ fd, 16v, 20%
5281-09246-00	U14	IC, 2-4 Dec, 74LS139	5041-09243-00	C25, C28	Capacitor, 10 μ fd, 10v, \pm 10%
5281-09745-00	U15	IC, Dual Mux, 74LS138	5043-08980-00	C5, B (17)*	Capacitor, 0.01 μ fd, 50v, +80, -20%
5370-09156-00	U22, U23	IC, Audio Amp, TDA2002	5043-08996-00	C31, C33	Capacitor, 0.1 μ fd, 50v, \pm 20%
a) 5705-09199-00		Heatsink, #6030B	5043-09065-00	C13 - C15	Capacitor, 470 pfd, 50v, \pm 20%
b) 4006-01003-06		Mach. Screw, 6-32 x 3/8	5043-09492-00	C2, C34	Capacitor, 100 pfd, 50v, \pm 10%
c) 4406-01117-00		Nut, 6-32 Hex.	5043-09844-00	C6	Capacitor, 47 pfd, 50v, \pm 20%
d) 4703-00007-00		Lockwasher, #6 Ext.	5043-09845-00	C16, C18, C20 - C23, C27	Capacitor, 1000 pfd, 50v, \pm 20%
5160-10269-00	Q1	Transistor, 2N3904, NPN	5520-09020-00	X1	Crystal, 3.58 MHz
5060-10396-00	SP1	SIP 4.7K & 470pfd, 8R8C	5521-10931-00	CR1	Oscillator, 8 MHz
5010-09181-00	R44, R48	Resistor, 1.0 Ω , 1/2w, 5%	5551-09822-00	L1 - L3	Inductor, 4.7 μ H, 3A
5010-09161-00	R35, R45	Resistor, 2.2 Ω , 1/4w, 5%	5791-09437-00	J4	Connector, 20 pin, (Hdr), Rib. Cbl
5010-09361-00	R43, R46, R47	Resistor, 220 Ω , 1/2w, 5%	5791-10862-04	J1, J2, J5	Connector, 4 pin (Hdr)
5010-09358-00	R41, R42	Resistor, 1K, 1/4w, 5%	5791-10862-06	J3	Connector, 6 pin (Hdr)
5010-08998-00	R2, R3,	Resistor, 2.2K, 1/4w, 5%	16-8850-250		P.C.B. I.D. Label
5010-08983-00	R7-R9	Resistor, 3.3K, 1/4w, 5%	20-9229		Thermal Compound
5010-08991-00	R1, R4, R5, R11, R25 - R28, R33, R36, R37, R49, R50	Resistor, 4.7K, 1/4w, 5%			

NOTES:

- * 17 capacitors (shown on diagram with "B" symbol) provide +5VDC filtering for ICs.
- All capacitors are ceramic, 50v, axial, unless otherwise noted.
- All resistors are 5%, 1/4w, Carbon Film, unless otherwise noted.

Y-UNIT CPU BOARD

INDICATES
LETTERS FROM

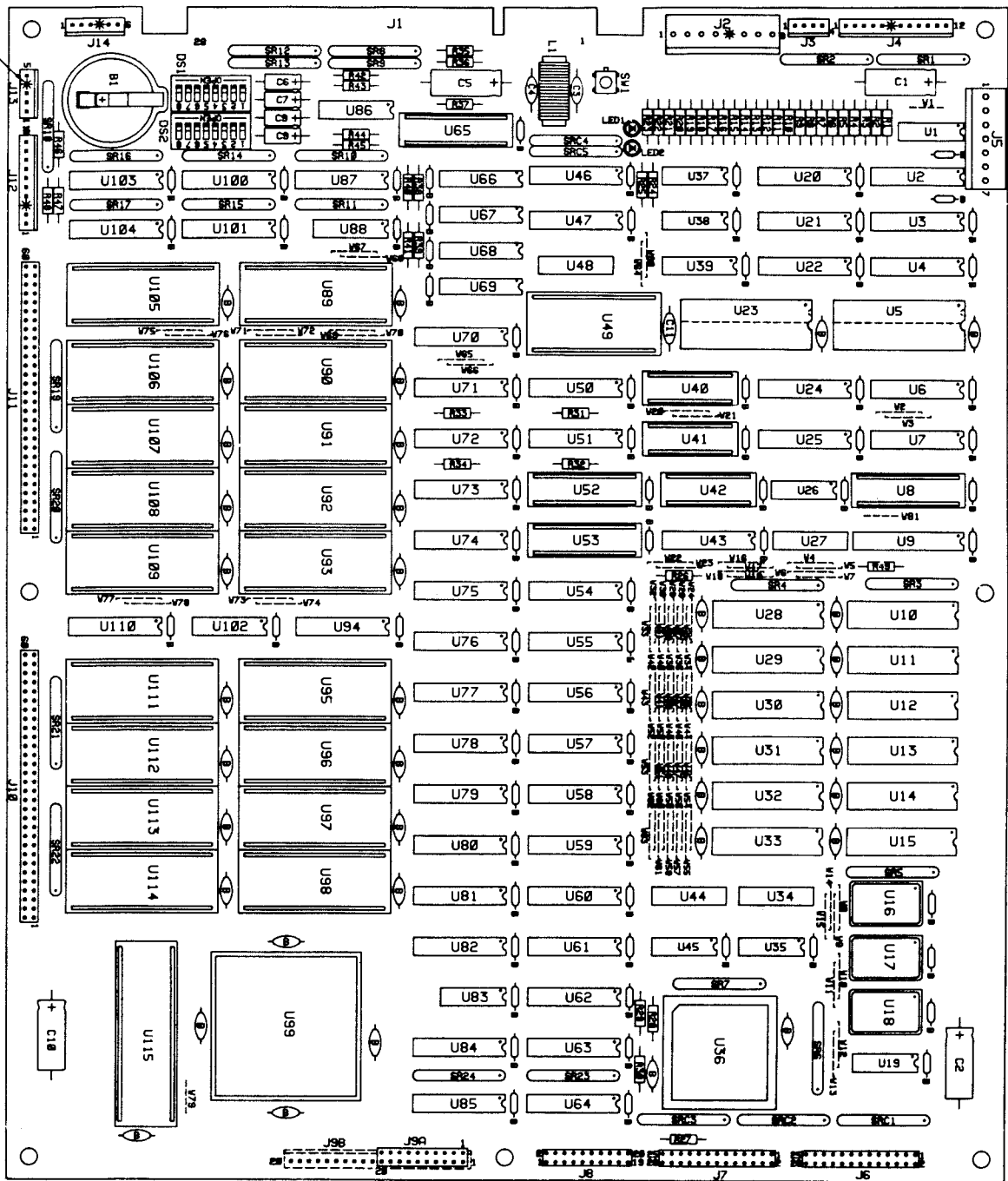

C-13234-40003 Y-unit CPU Board Assembly

Part No.	Ckt.Designator	Description	Part No.	Ckt.Designator	Description
5770-12555-00		Bare PC Brd.	5043-08980-00	B	Cap. .01 µfd 10V
5281-09737-00	U1	IC, 74LS 86	5040-08986-00	C1, C2, C5, C10	Cap. 100µfd 10V
5317-12211-00	U2, U20, U24, U43		5043-09845-00	C3, C4	Cap. .001µfd 10V
	U61, U62, U70	IC, 74ALS541	5041-09243-00	C6-C9	Cap. 10µfd 10V
5317-12212-00	U3, U6, U7, U21, U25	74ALS574	5043-8996-00	C11	Cap. .1µfd
	U50, U58, U63, U64		5019-12611-00	SR1, SR2, SR8	SIP, 470Ω 5 Res.
	U71, U72, U74, U79, U84, U85			SR9, SR12, SR13	
5317-12208-00	U4, U22, U54-U57	74ALS245		SR18	
	U59, U60, U75-U78		5019-09362-00	SR3, SR4, SR6	SIP, 4.7KΩ
	U80, U81, U94, U110			SR7, SR11, SR15	
5340-12242-00	U5, U23	IC, 8K x 8 S RAM		SR17, SR19-SR24	
5700-12047-00	U8, U52, U53, U65	24 pin Socket		SRC1-SRC3	
5340-12213-00	U10, U11, U28-U33	IC, 4461 VRAM	5019-10143-00	SR5	SIP, 470Ω 9 Res.
5521-12604-00	U16	40 MHZ Xtal	5060-10396-00	SRC4, SRC5	SIP. 4.7KΩ 470pf
5521-10318-00	U17	24 MHZ Xtal		SRC10, SRC14	
5283-10468-00	U19, U45	IC, 74F74		SRC16	
5019-10849-00	U27, U34, U44, U48	100Ω DIP Res.	5671-09019-00	LED1, LED 2	LED, Red
5317-12305-00	U35	IC, 74ALS00	5551-09822-00	L1	Inductor, 4.7UH
5700-12253-00	U36	68 pin Socket	5645-09025-00	DS1, DS2	DIP. Sw. 16 pin
5280-09309-00	U37	IC, 7407	5641-12551-00	SW1	Pushbutton Sw.
5281-09487-00	U38	IC, 74LS74	5881-12315-00	B1	Battery Holder
5434-12255-00	U39	IC, MAX691	5791-10862-08	J2	8 pin Connector
5700-09915-00	U40-U42	20 pin Socket	5791-12461-12	J4	12 pin Connector
5311-12287-00	U47, U46, U87, U100	IC, 74HC541	5791-10850-00	J6, J7	26 pin Ribbon Connector
	U101, U103, U104			J8	20 pin Ribbon Connector
5700-10176-00	U49	28 pin Socket	5791-09437-00	J8	20 pin Ribbon Connector
5311-12285-00	U51, U73, U82	IC, 74HC573		J12	10 pin Connector
5340-12014-00	U66-U69	IC, 4464 DRAM	5791-124-10	J12	CPU Sub-assembly
5283-10552-00	U83	IC, 74F04	C-13235-2		IC, PLD Color RAM Control
5370-12602-00	U86	IC, ULN2064B	A-5346-40003-1	U8	IC, TMS 30410
5317-12023-00	U88	IC, 74ALS138	5400-12220-00	U36	IC, PLD Address Decoder
5700-12088-00	U89-U93, U95-U98	32 pin Socket	A-5346-40003-2	U40	IC, PLD Video RAM Control
	U105-U109, U111-U114		A-5346-40003-3	U41	IC, 8K x 8 Static RAM
5700-12254-00	U99	144 pin Socket	A-5346-40003-4	U42	IC, PLD Video RAM Sequen.
5700-08985-00	U115	40 pin Socket	A-5346-40003-5	U52	IC, PLD Image ROM Control
5010--08991-00	R1,R24, R27	Res. 4.7KΩ 5% 1/4W	A-5346-40003-6	U53	IC, PLD Misc. Control
5010-10204-00	R2, R7, R12	Res. 1KΩ 2% 1/4W	A-5346-40003-7	U65	IC, Game EPROM
5010-10205-00	R3, R8, R13	Res. 2KΩ 2% 1/4W	A-5343-40003-1	U89	IC, Game EPROM
5010-10000-00	R4, R9, R14	Res. 3.9KΩ 5% 1/4W	A-5343-40003-2	U90	IC, Game EPROM
5010-09219-00	R5, R10, R15	Res. 8.2KΩ 5% 1/4W	A-5343-40003-3	U91	IC, Game EPROM
5010-08772-00	R6, R11, R16	Res. 15KΩ 5% 1/4W	A-5343-40003-4	U92	IC, Game EPROM
5010-09001-00	R23, R25	Res. 330Ω 5% 1/4W	A-5343-40003-5	U93	IC, Game EPROM
5010-09036-00	R26, R29-R34	Res. 100Ω 5% 1/4W	A-5343-40003-6	U95	IC, Game EPROM
5010-09416-00	R35-R37, R46-R48	Res. 470Ω 5% 1/4W	A-5343-40003-7	U96	IC, Game EPROM
5010-08997-00	R38-R45	Res. 2.7Ω 5% 1/4W	A-5343-40003-8	U97	IC, Game EPROM
5010-09534-00	W2, W8, W11, W12	Res. 0Ω	A-5343-40003-9	U98	IC, Game EPROM
	W14, W20, W22, W24		5410-12239-00	U99	IC, Custom ASIC
	W27, W28, W31, W32,		A-5343-40003-10	U105	IC, Game EPROM
	W35, W39, W41, W43		A-5343-40003-11	U106	IC, Game EPROM
	W44, W46, W48, W50,		A-5343-40003-12	U107	IC, Game EPROM
	W52, W54, W56, W58		A-5343-40003-13	U108	IC, Game EPROM
	W60, W62, W66, W68,		A-5343-40003-14	U109	IC, Game EPROM
	W69, W72, W74, W76		A-5343-40003-15	U111	IC, Game EPROM
	W78, W80		A-5343-40003-16	U112	IC, Game EPROM
			A-5343-40003-17	U113	IC, Game EPROM
			A-5343-40003-18	U114	IC, Game EPROM
			A-5343-40003-8	U115	IC, Game EPROM
			5880-11056-00	B1	Battery, Lithum 3V
			03-8338-1		1/4 Inch Spacer

C-13253-1 Power Supply

Part Number	Description
20-9633	Switcher Power Supply
01-9254	Shield

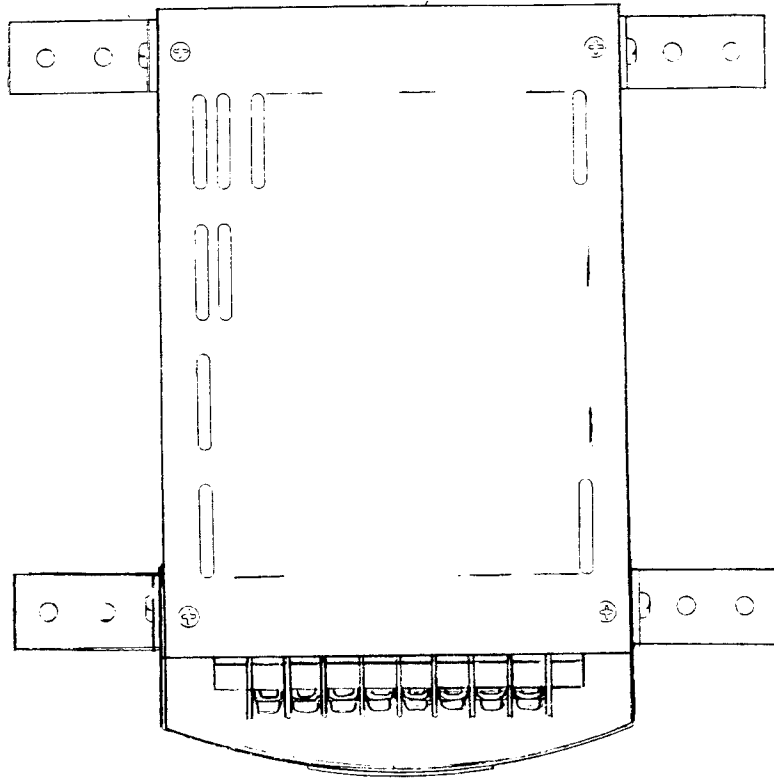

TROG

S E C T I O N
three

Diagrams & Schematics

**TROG
JAMMA Chart**

FUNCTION	WIRE COLOR	PIN	PIN	WIRE COLOR	FUNCTION
Ground	Blk	1	A	Blk	Ground
Ground	Grn-Brn	2	B	Blk	Ground
+5 Volts DC	Gry	3	C	Gry	+5 Volts DC
+5 Volts DC	Gry	4	D	Gry	+5 Volts DC
-5 Volts DC	Gry-Grn	5	E	Gry-Grn	-5 Volts DC
+12 Volts DC	Gry-Yel	6	F	Gry-Yel	+12 Volts DC
	Key	7	H	Key	
Counter 1	Wht-Orn	8	J	Wht-Grn	Counter 2
	NC	9	K	NC	
Speaker (+)	Red-Vio	10	L	Grn-Vio	Speaker (-)
	NC	11	M	NC	
Video Red	Red	12	N	Grn	Video Grn
Video Blue	Brn	13	P	Wht	Video Sync
Video Grd	Shield	14	R	Wht-Red	Service Credit
Test	Grn	15	S	Wht-Vio	Slam Tilt
1 Coin	Wht-Blu	16	T	Yel-Wht	2 Coin
1 Start	Yel-Grn	17	U	Yel-Blu	2 Start
1 Up	Org-Blk	18	V	Yel-Blk	2 Up
1 Down	Org-Brn	19	W	Yel-Brn	2 Down
1 Left	Org-Red	20	X	Yel-Red	2 Left
1 Right	Org	21	Y	Yel-Org	2 Right
1 Punch	Org-Yel	22	Z	Yel-Vio	2Punch
NC	Org-Grn	23	a	Yel-Gry	NC
NC	Org-Blu	24	b	Vio-Blk	NC
NC	Org-Vio	25	c	Vio-Brn	NC
NC	Org-Gry	26	d	Vio-Red	NC
Ground	NC	27	e	NC	Ground
Ground	Blk	28	f	Blk	Ground

D-11581-40003 Audio Board Assembly

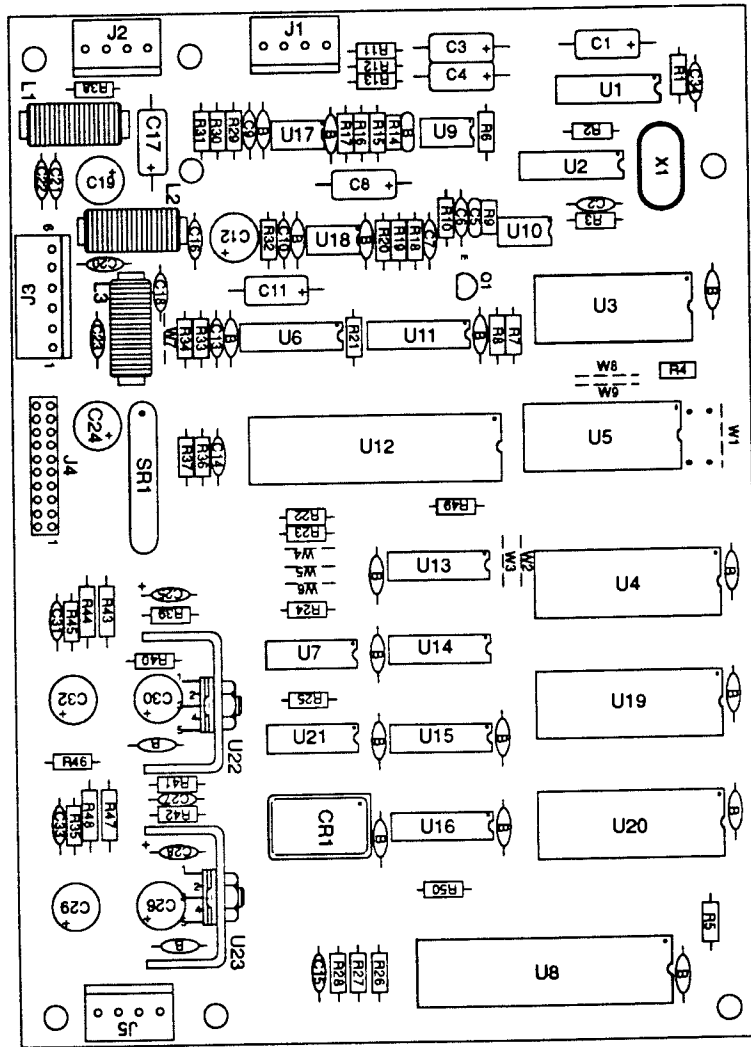

AUDIO BOARD SCHEMATIC

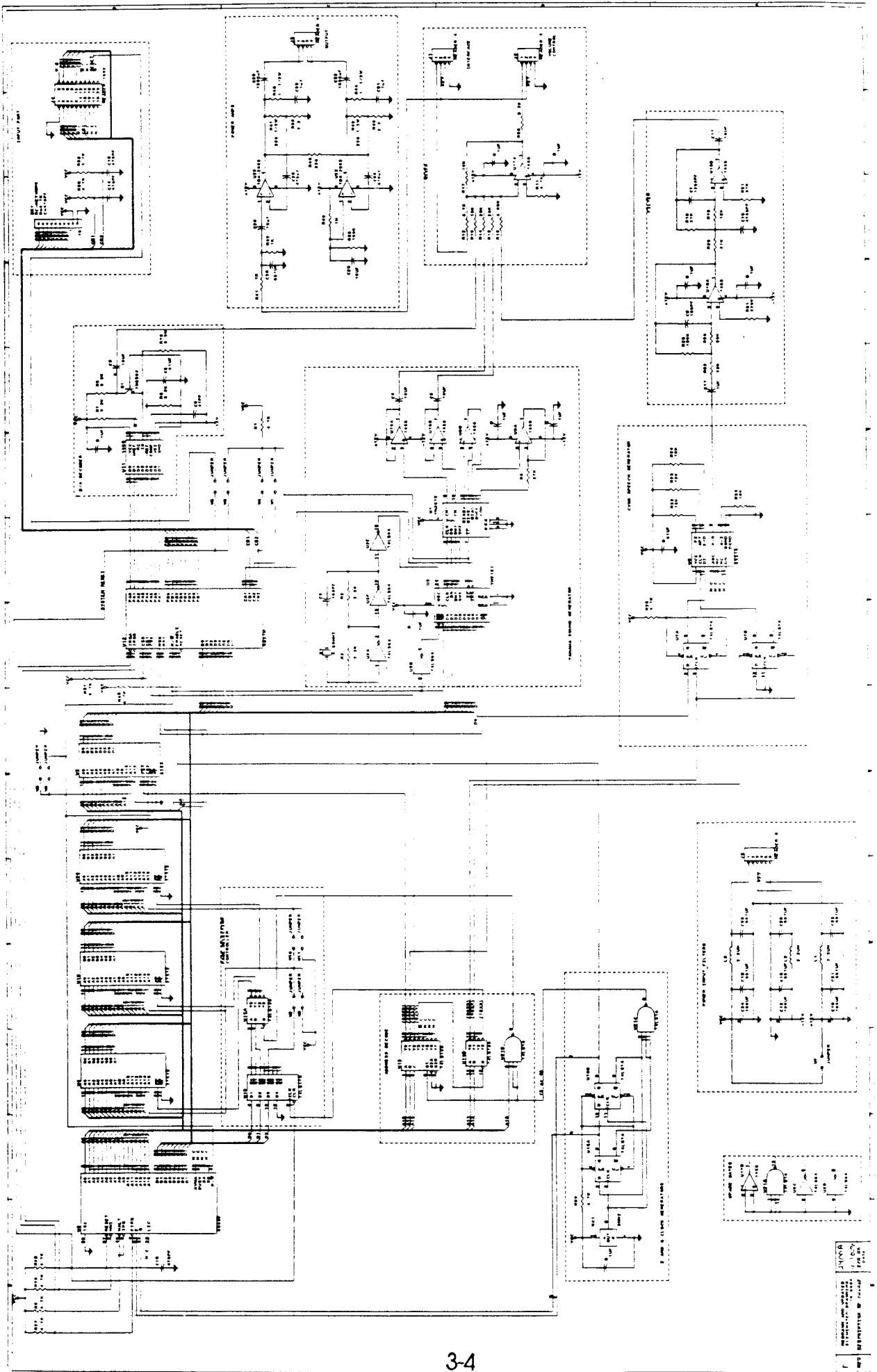

1. THIS SCHEMATIC IS THE PROPERTY OF THE U.S. GOVERNMENT AND IS TO BE REPRODUCED IN FULL.
 2. THIS SCHEMATIC IS THE PROPERTY OF THE U.S. GOVERNMENT AND IS TO BE REPRODUCED IN FULL.
 3. THIS SCHEMATIC IS THE PROPERTY OF THE U.S. GOVERNMENT AND IS TO BE REPRODUCED IN FULL.

A-13234-40003 Y-unit CPU Board Assembly

INDICATES
REVISION PLAN

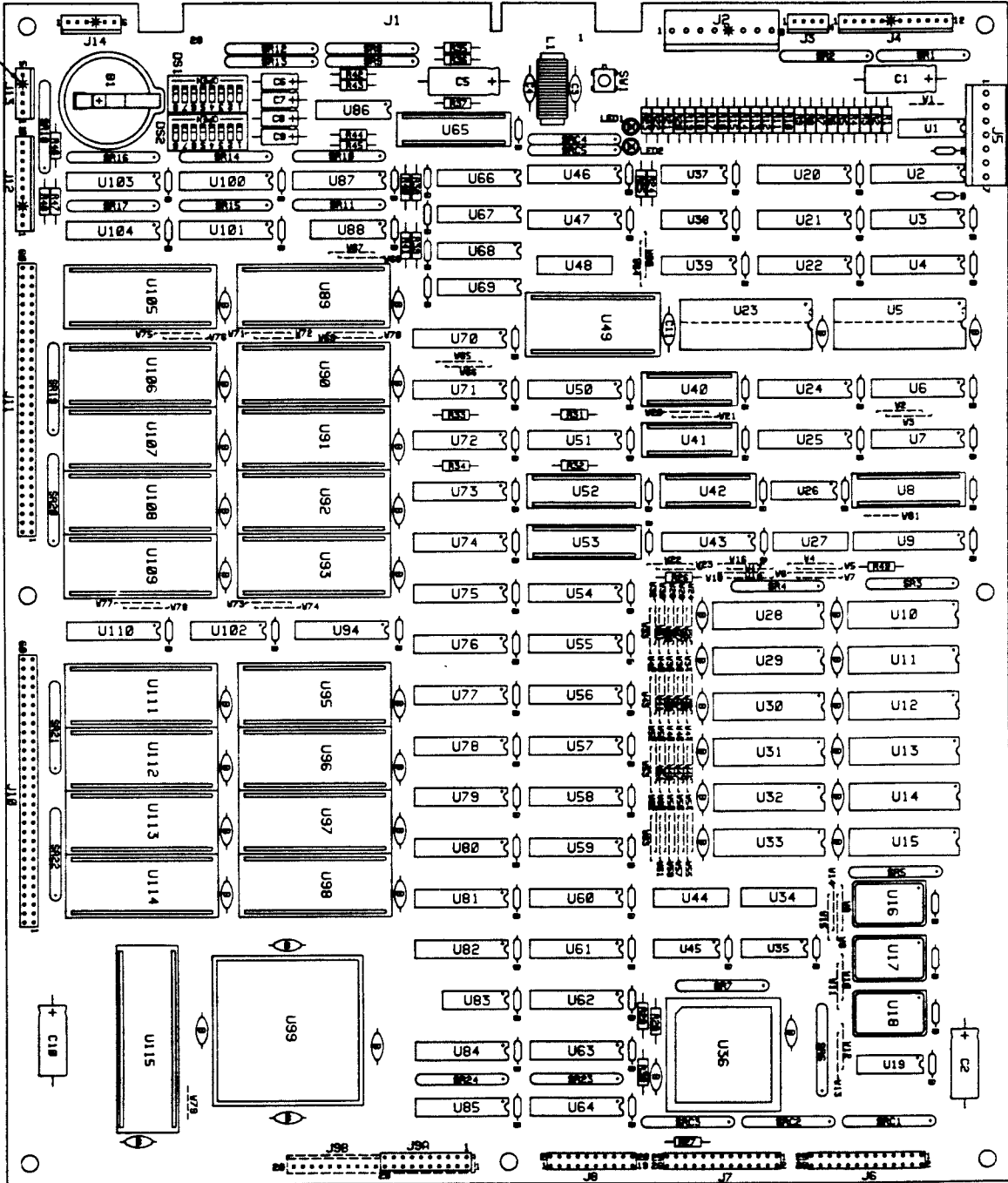

CPU Schematic

Sheet 1 of 16

36

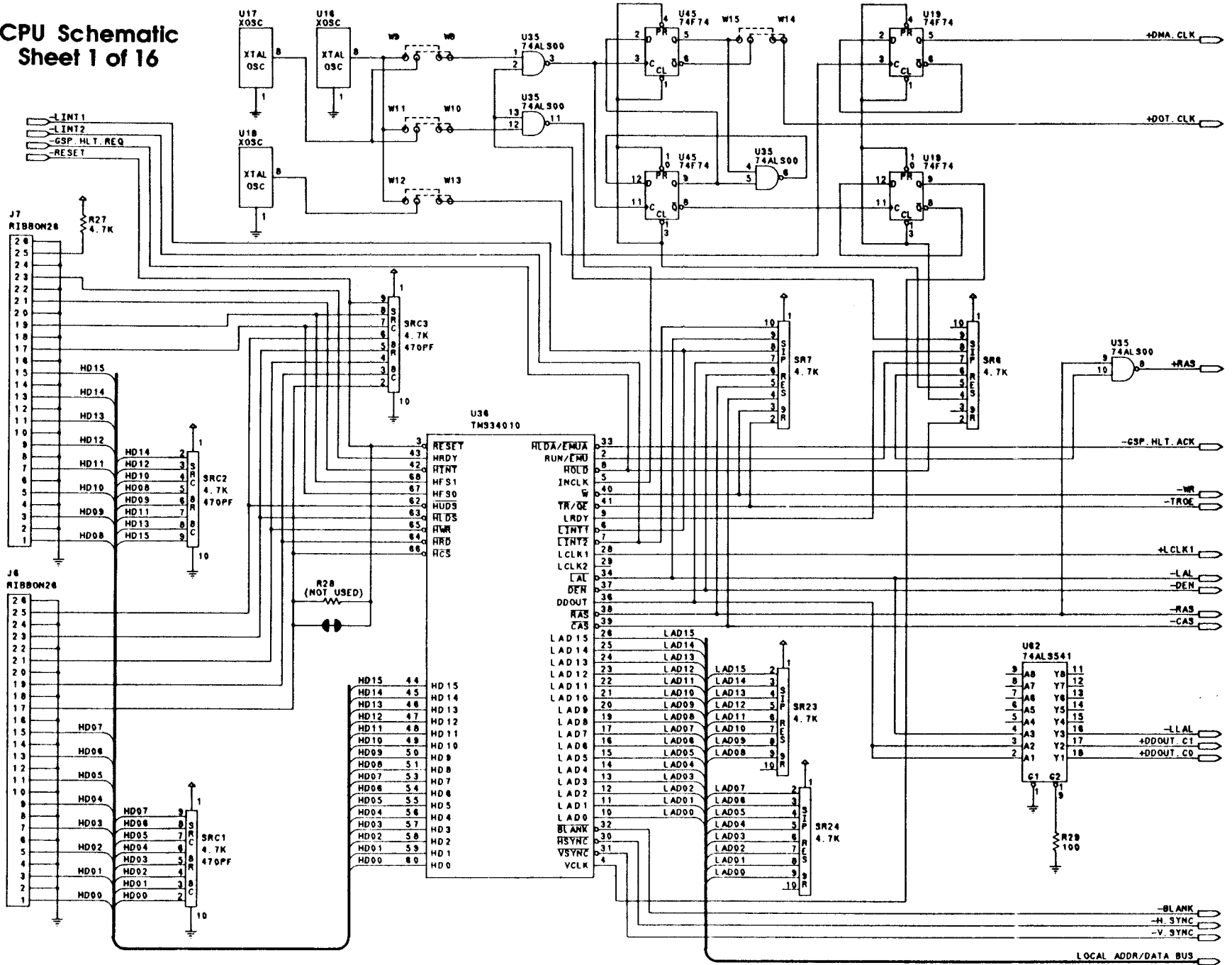

LOCAL_ADDR_BUS "X"

CPU Schematic Sheet 2 of 16

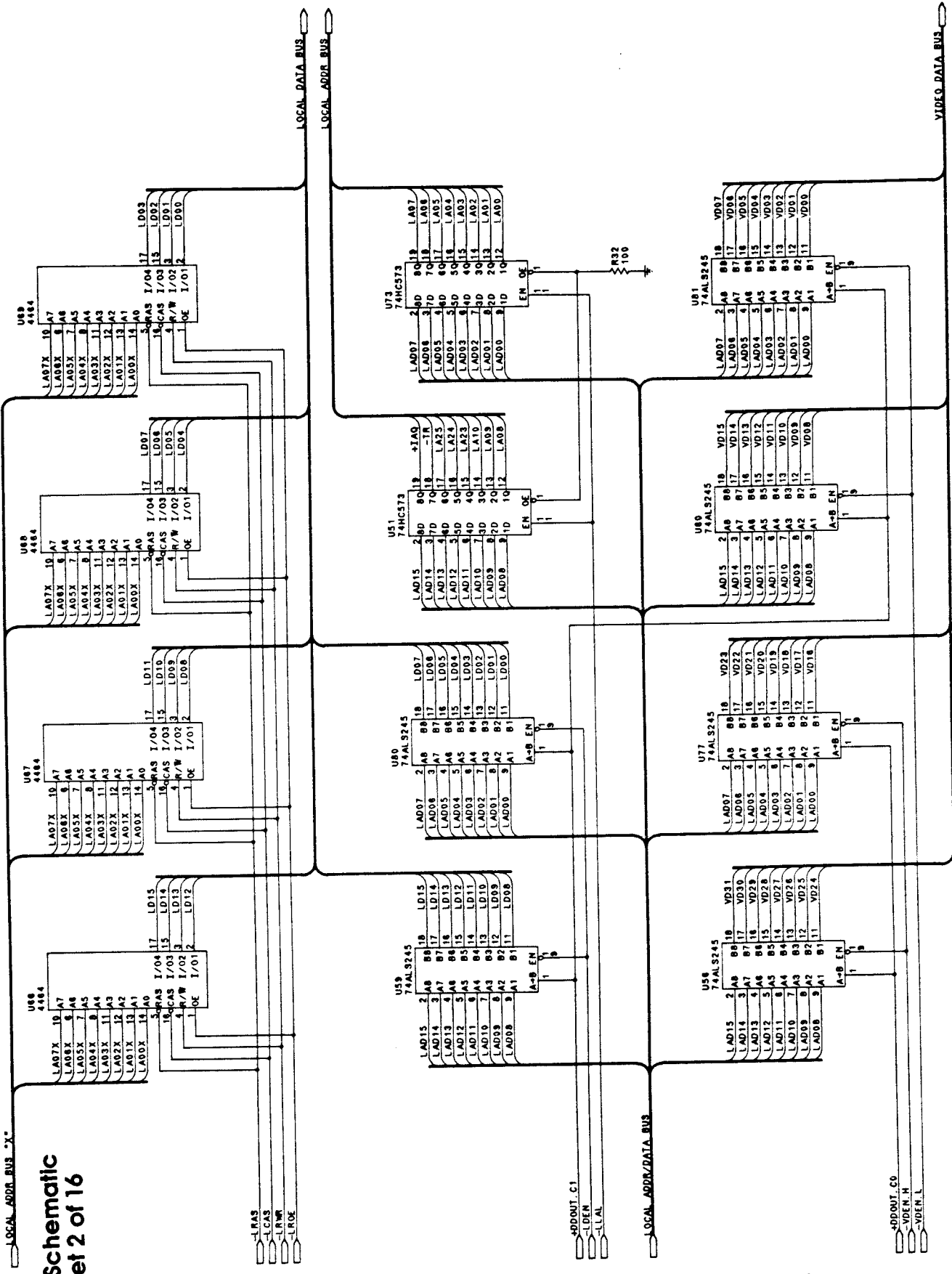

-LRAS
-LCAS
-LRWE
-LPOE

-DDOUT_C1
-LDEN
-LLAL

-DDOUT_C0
-VDEN_H
-VDEN_L

CPU Schematic
Sheet 3 of 16

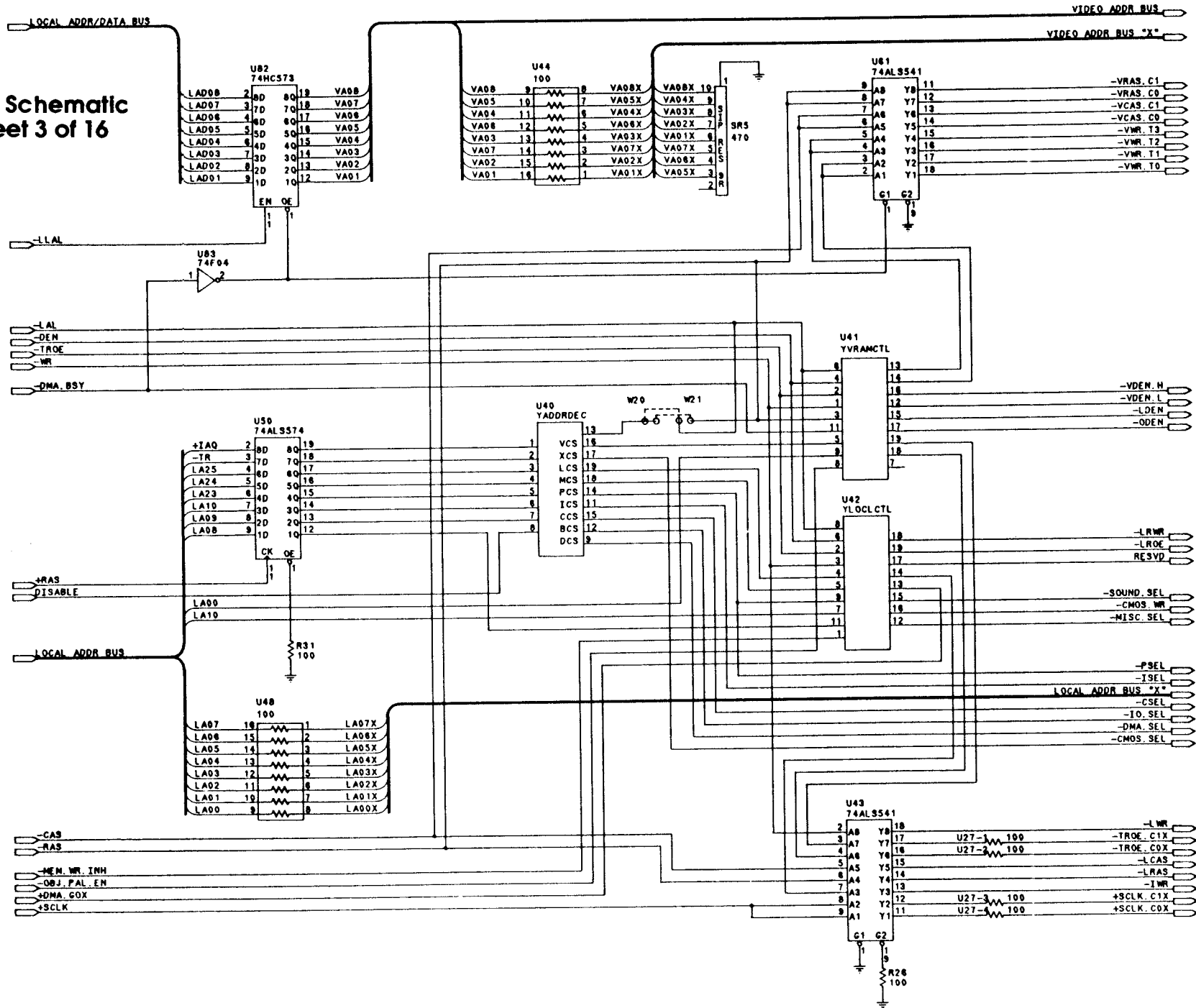

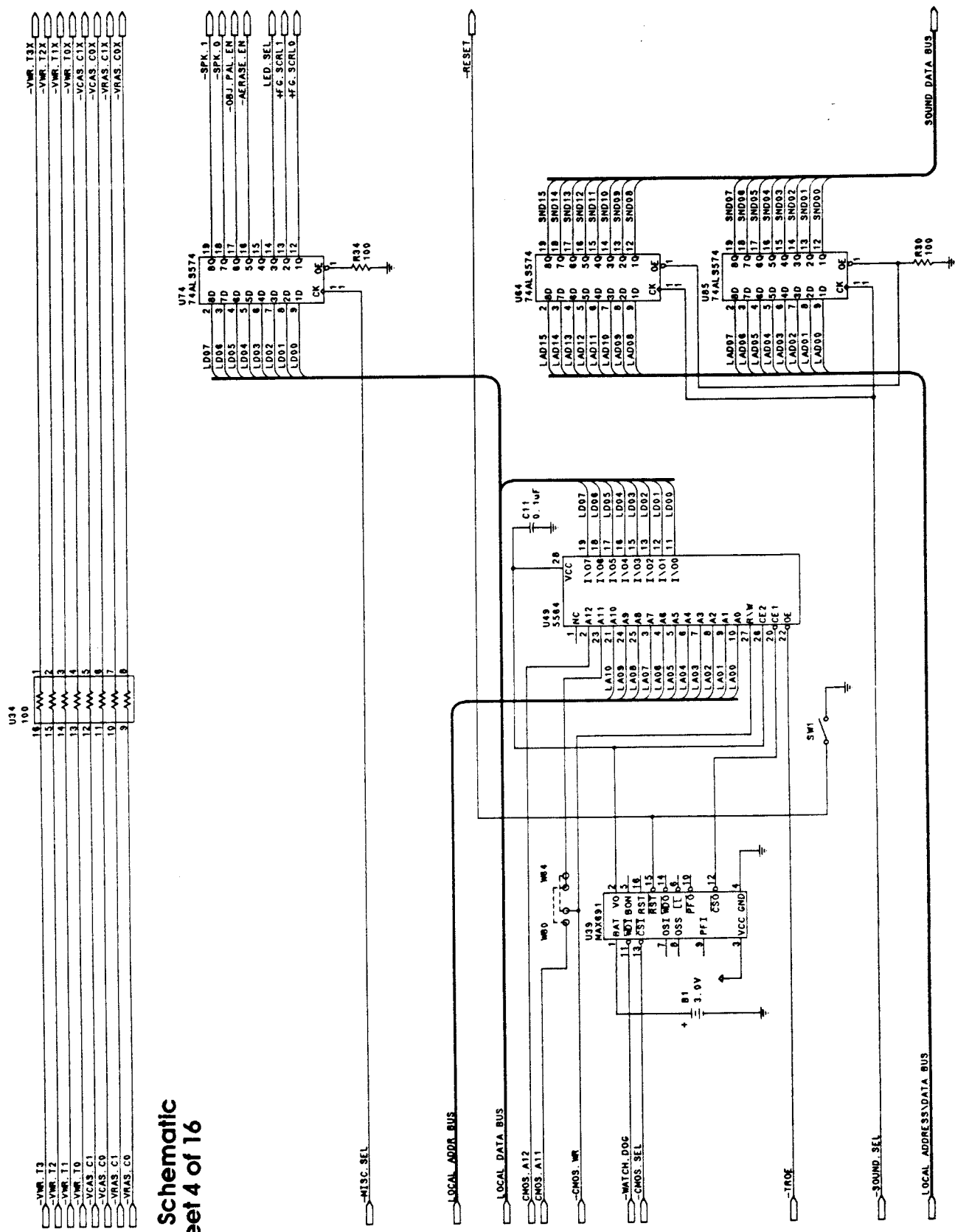

CPU Schematic Sheet 4 of 16

CPU Schematic Sheet 5 of 16

PROGRAM MEMORY

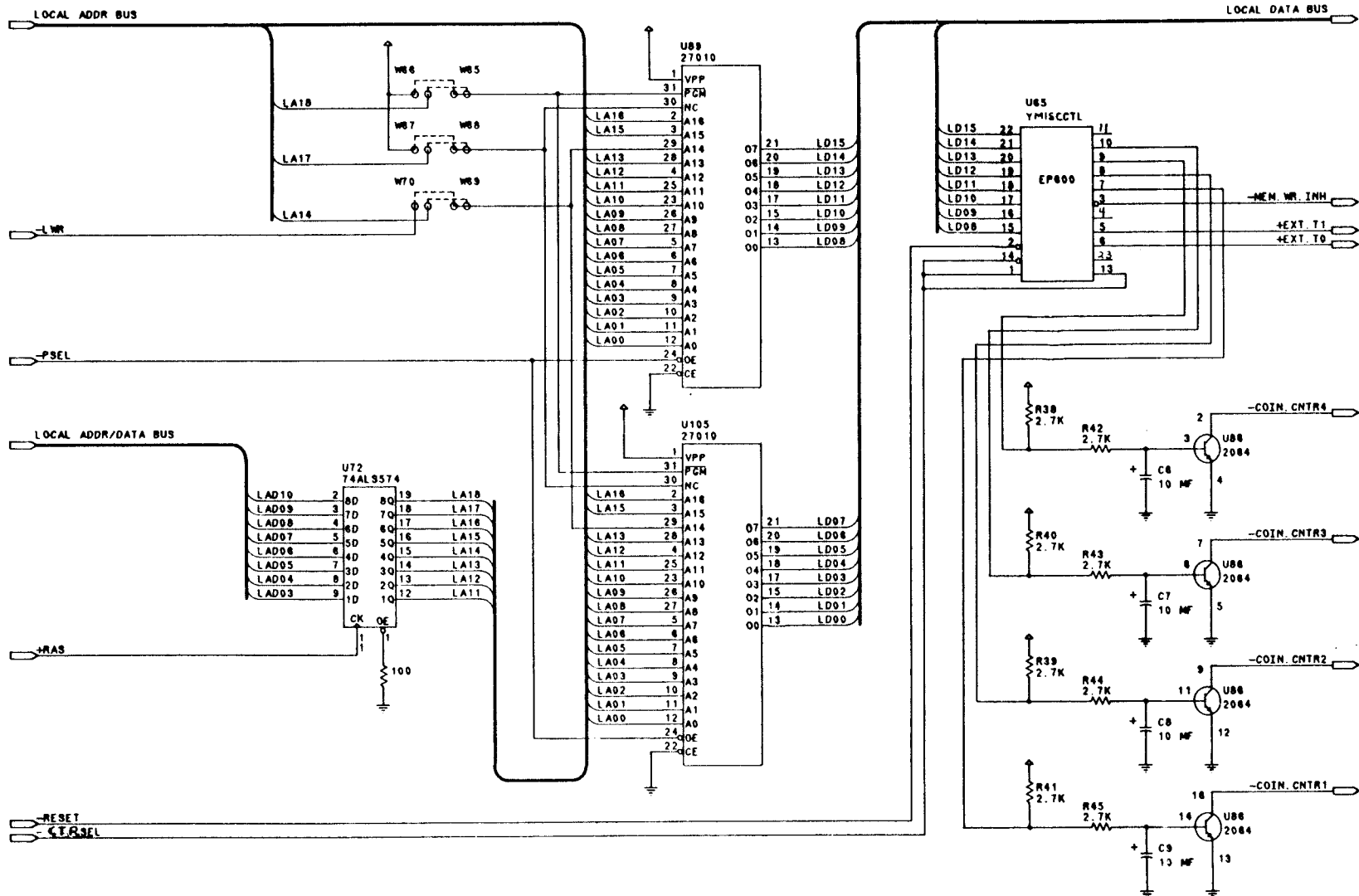

3-10

LOCAL_ADDR/DATA BUS

CPU Schematic Sheet 6 of 16

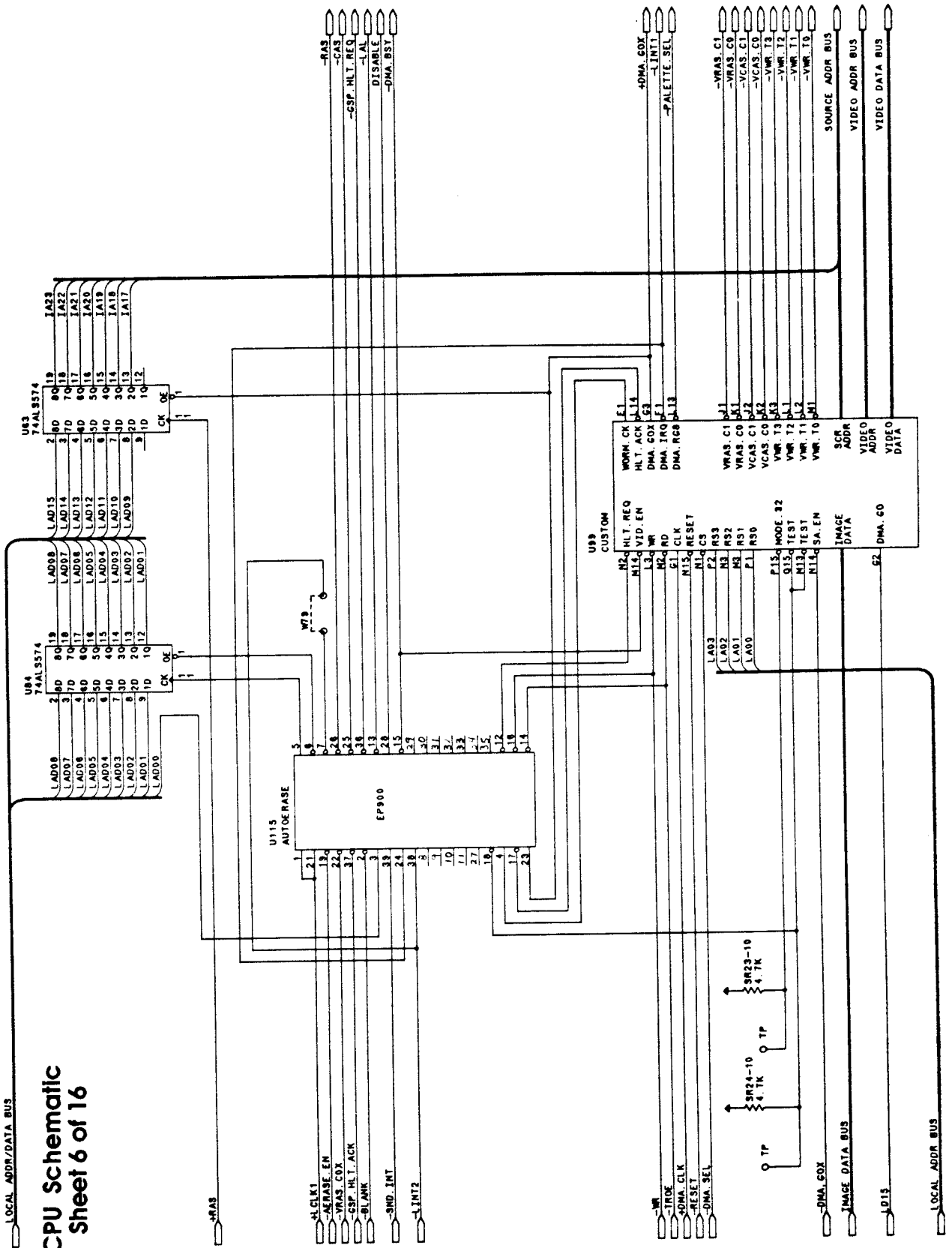

**CPU Schematic
Sheet 7 of 16**

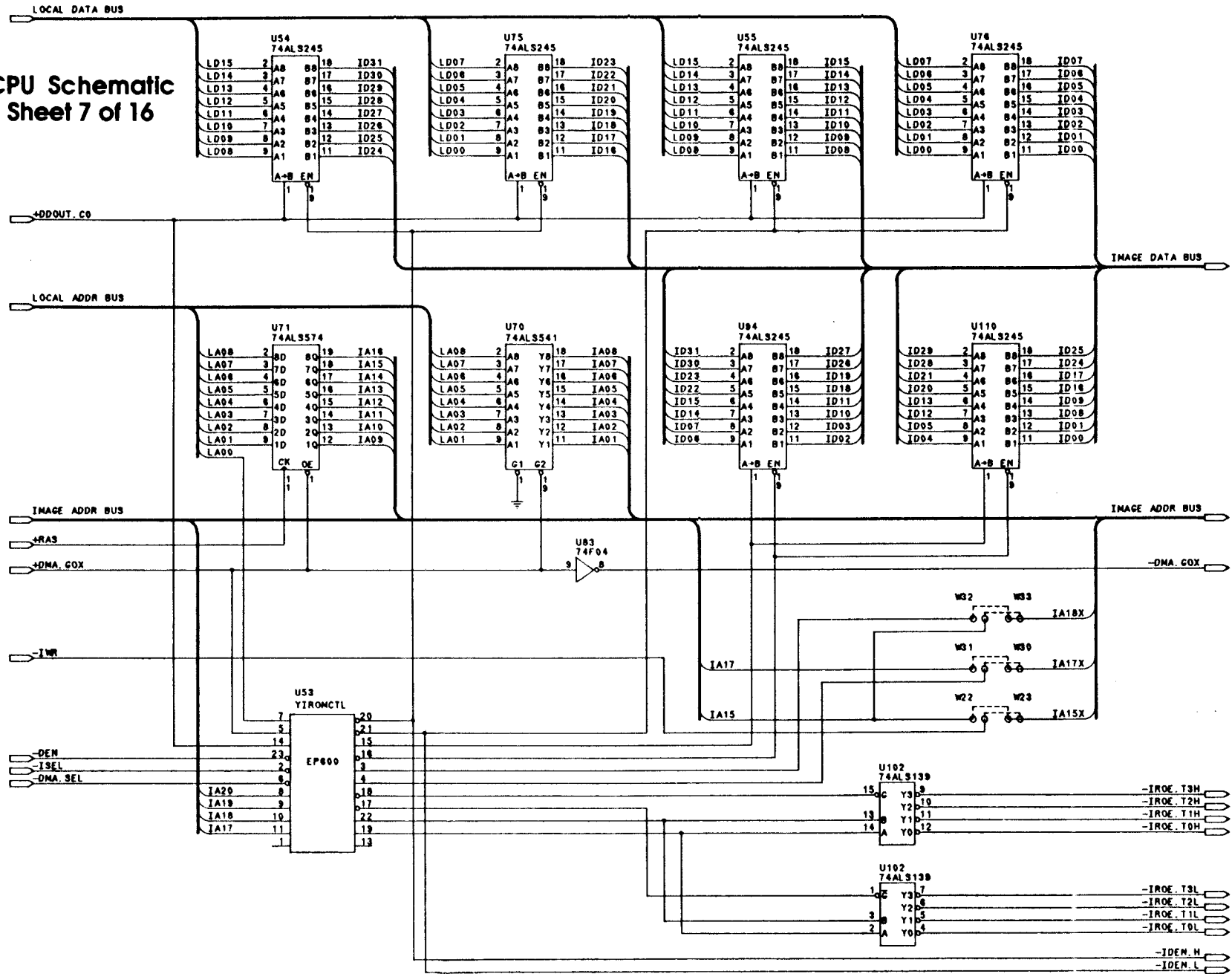

CPU Schematic Sheet 8 of 16

IMAGE MEMORY

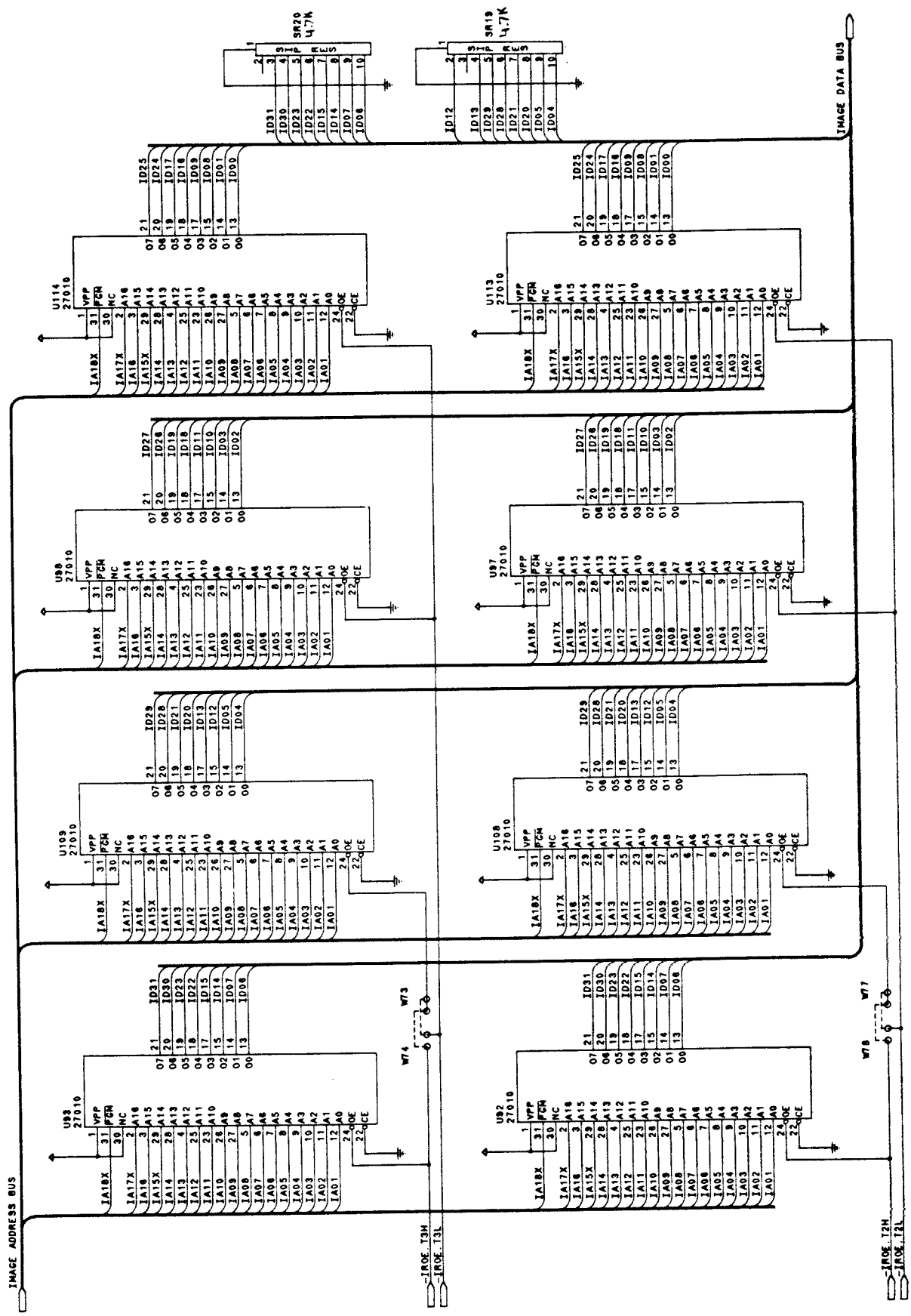

CPU Schematic Sheet 9 of 16

IMAGE MEMORY

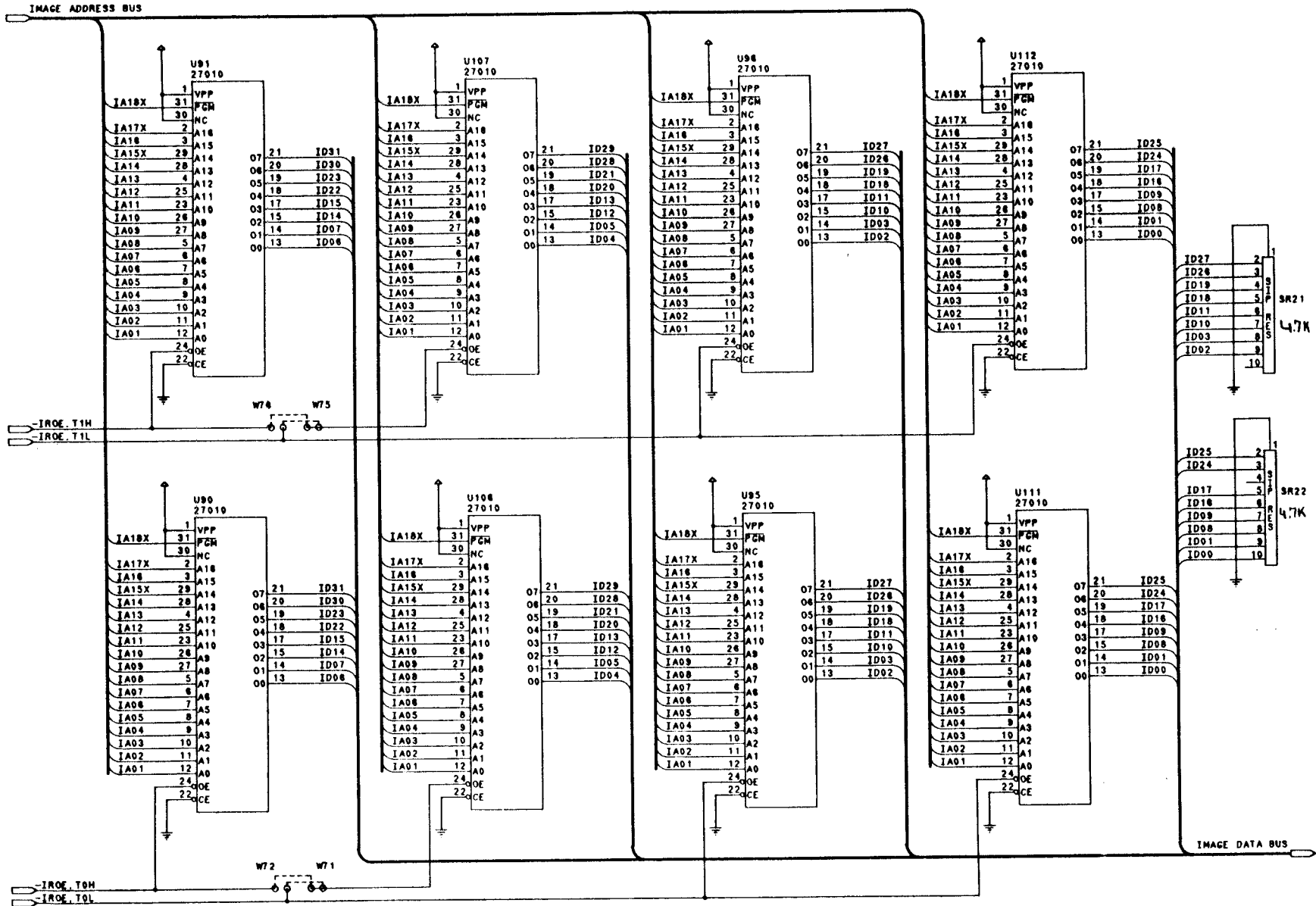

3-14

CPU Schematic Sheet 10 of 16

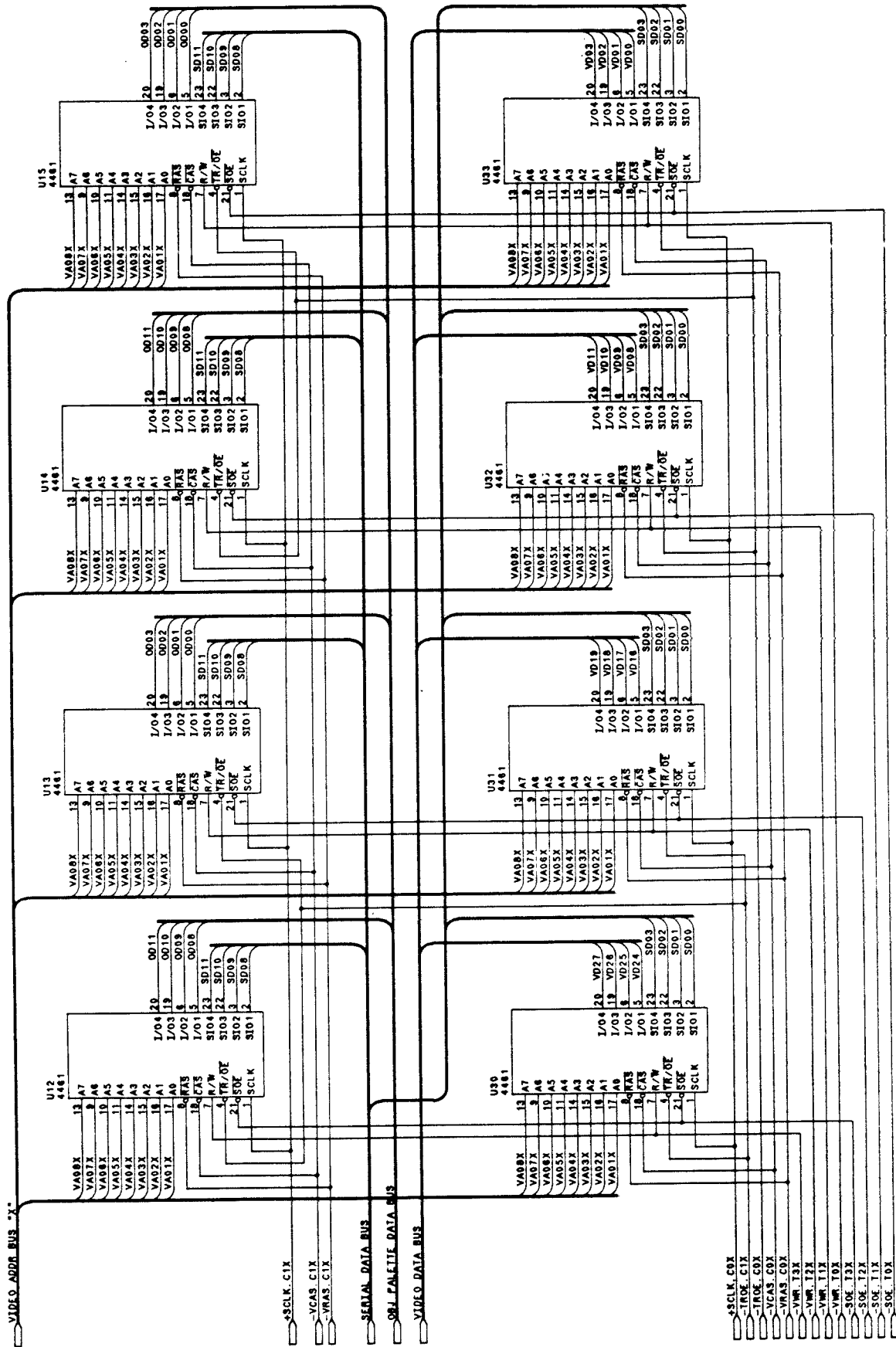

VIDEO ADDR BUS "X"

CPU Schematic Sheet 11 of 16

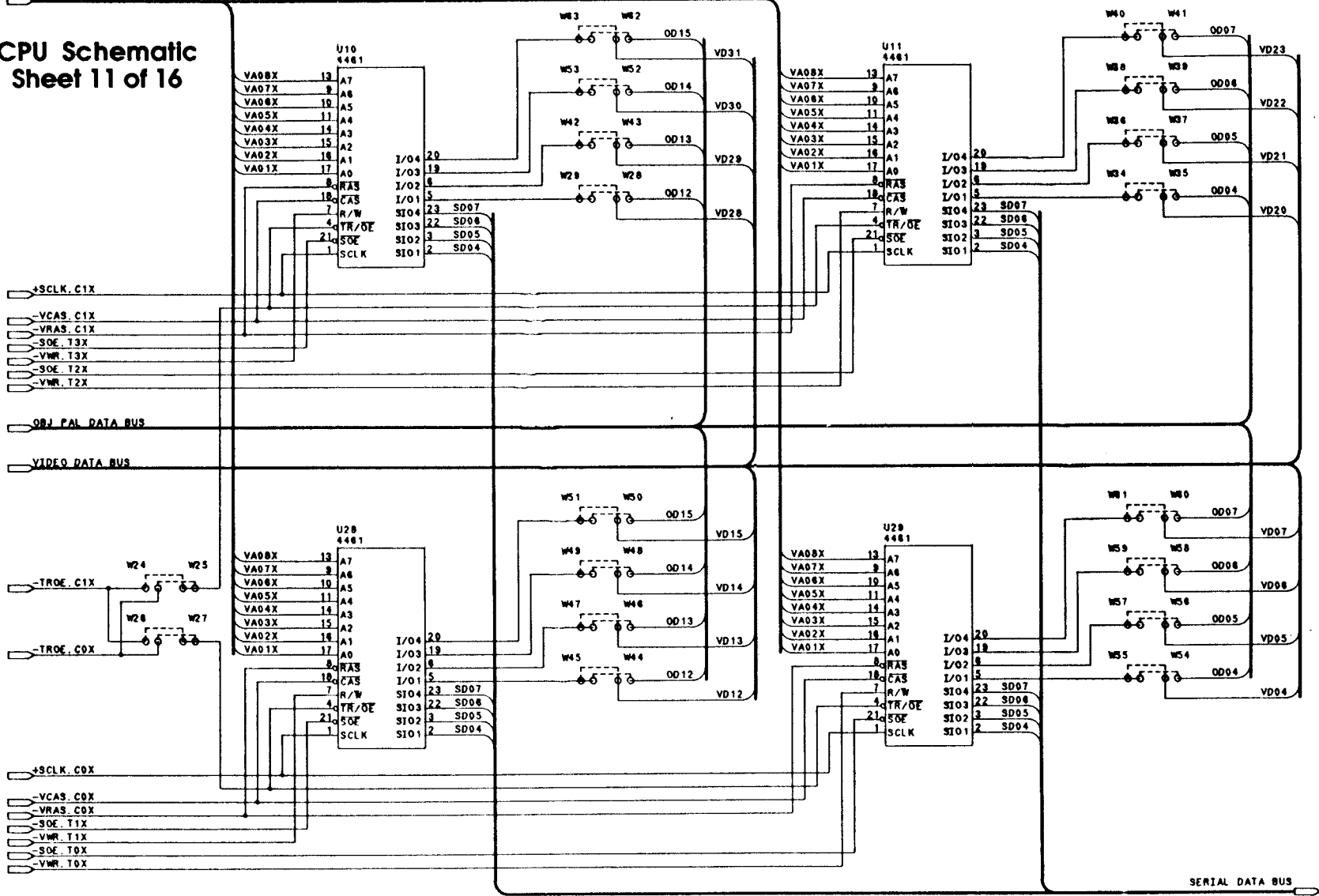

3-16

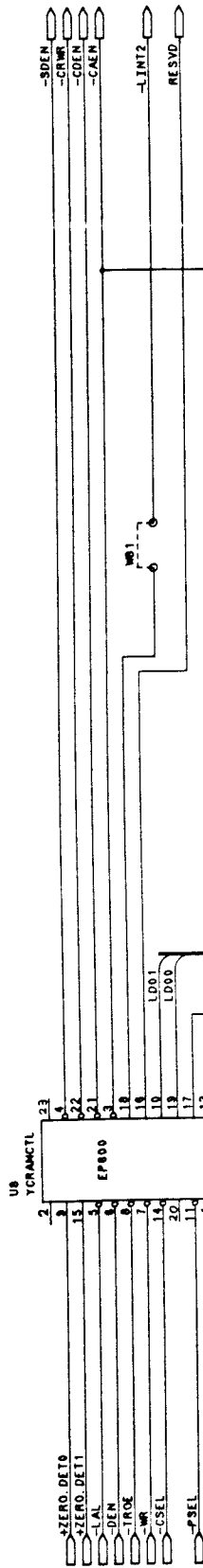

CPU Schematic
Sheet 12 of 16

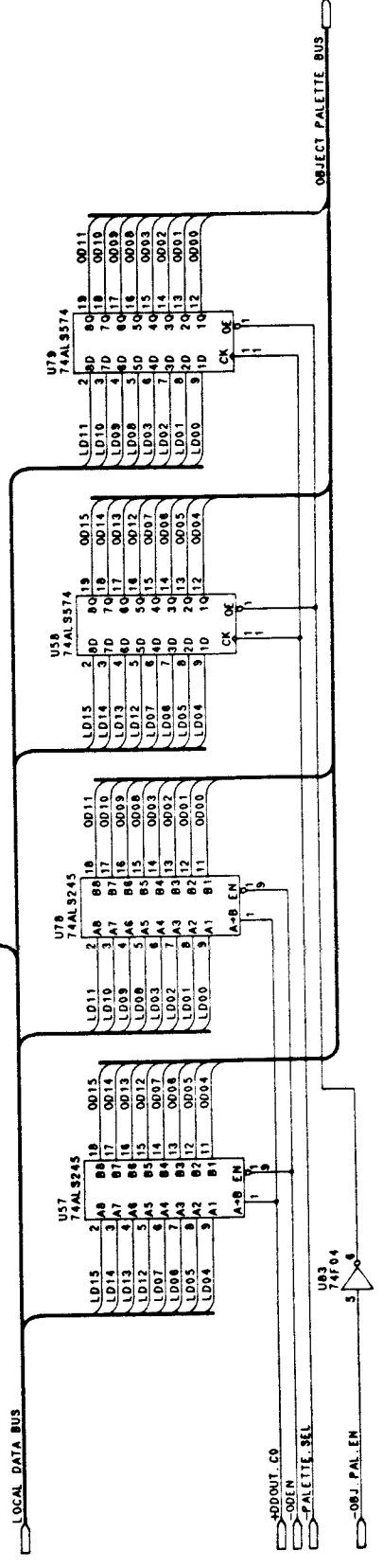
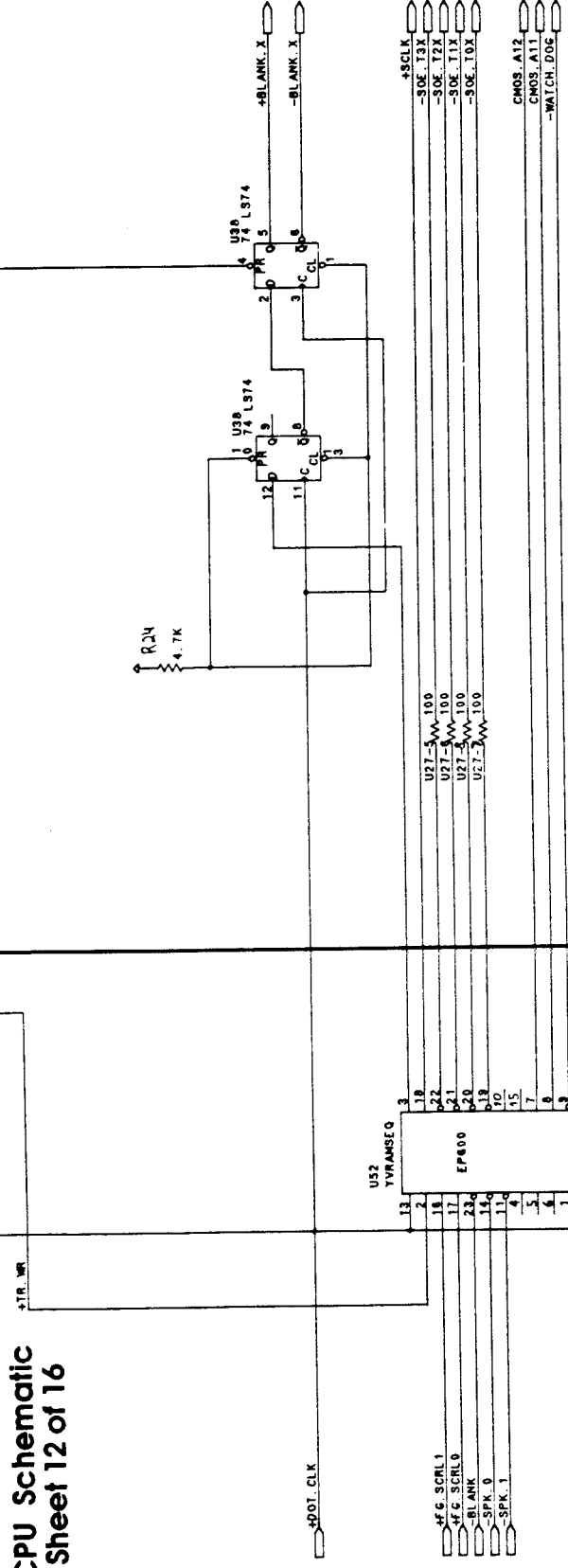

CPU Schematic
Sheet 13 of 16

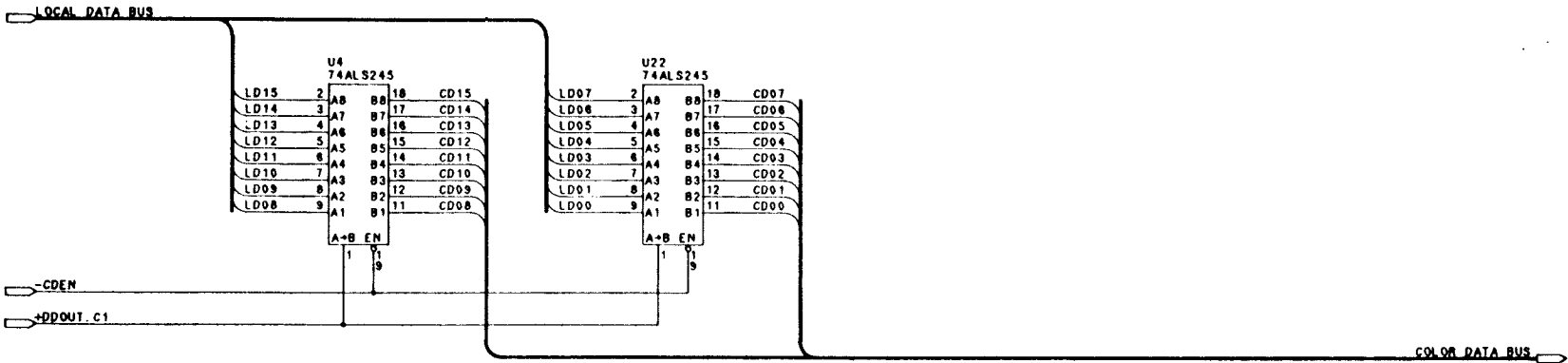
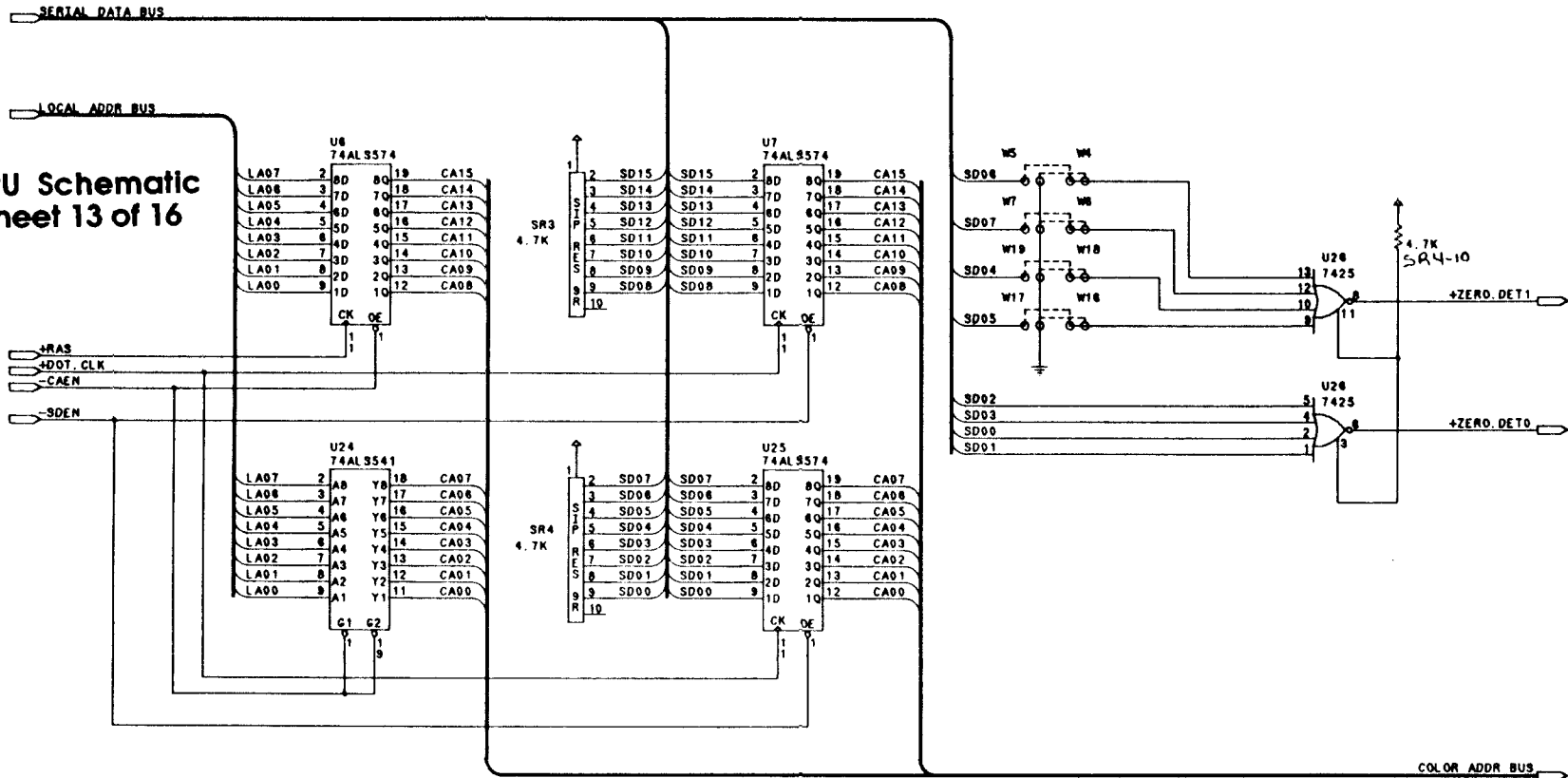

CPU Schematic Sheet 14 of 16

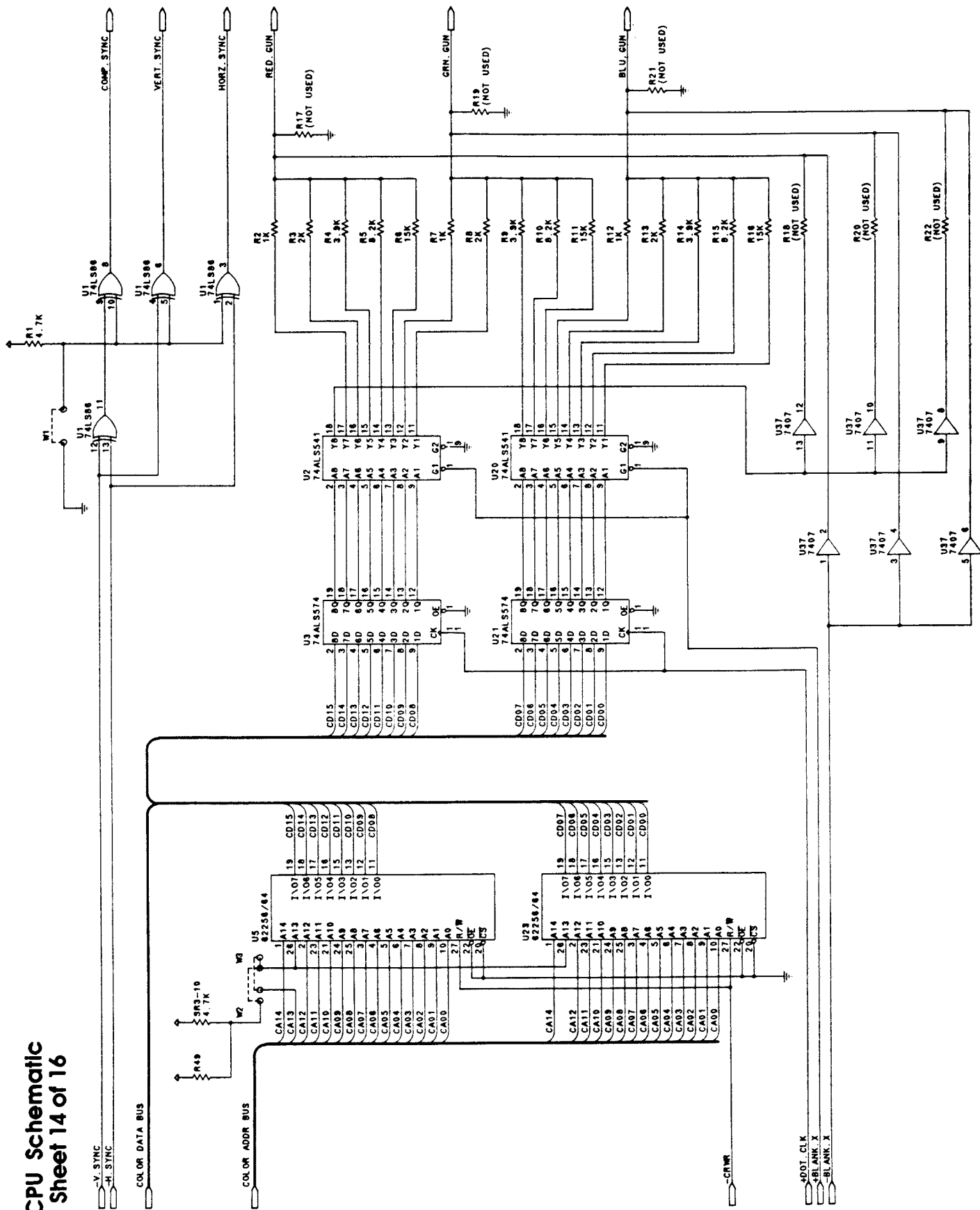

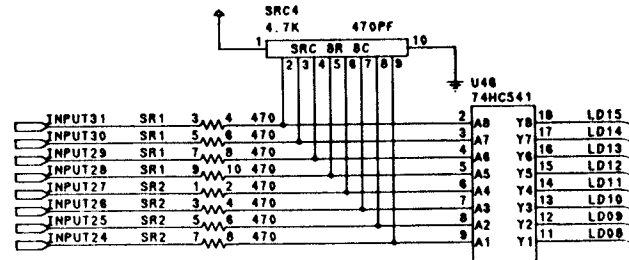
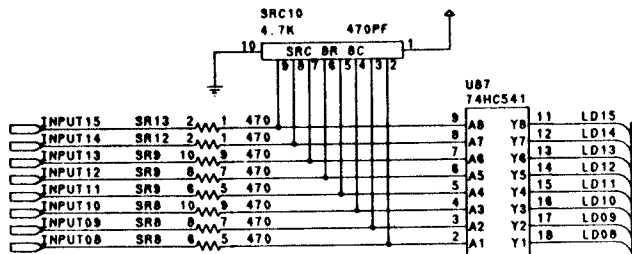

**CPU Schematic
Sheet 15 of 16**

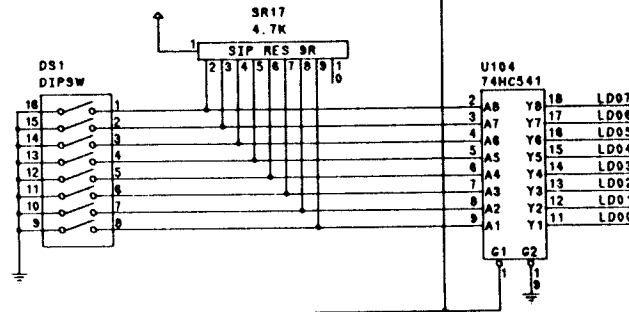
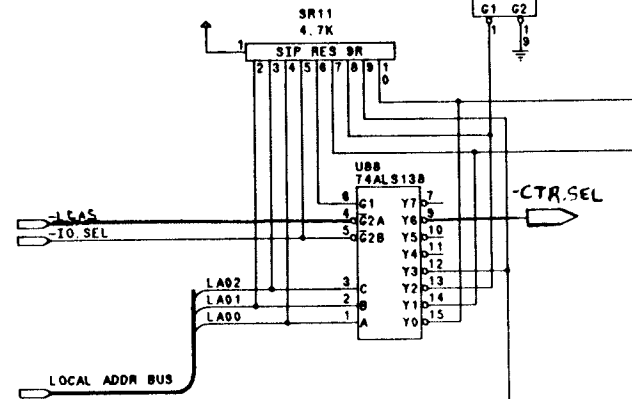
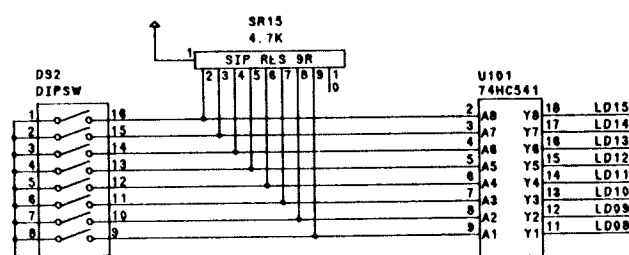
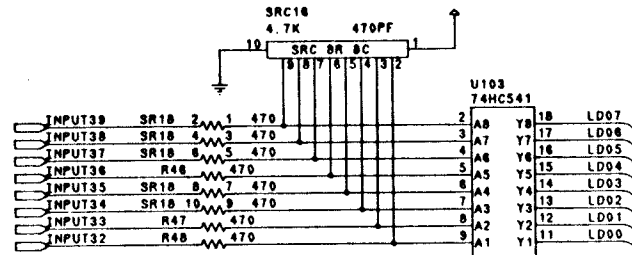
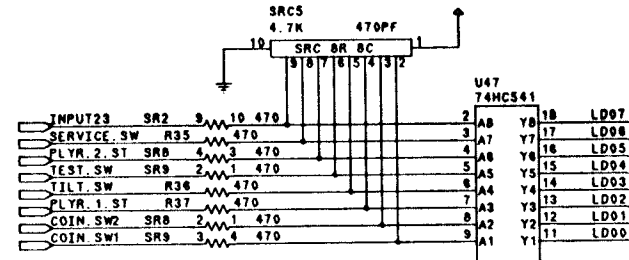
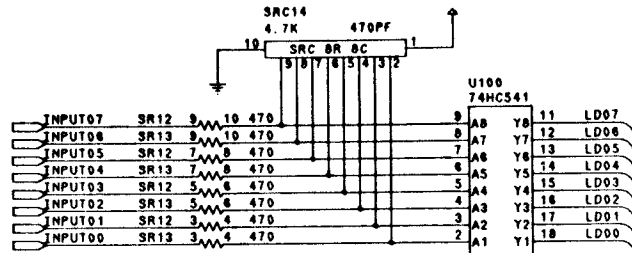

3-20

LOCAL DATA BUS

CPU Schematic Sheet 16 of 16

JAMMA INTERFACE

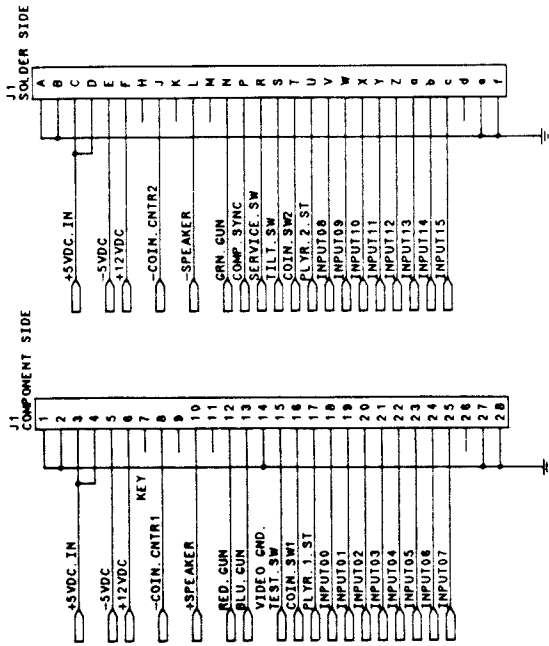

INTERRUPT INTERFACE

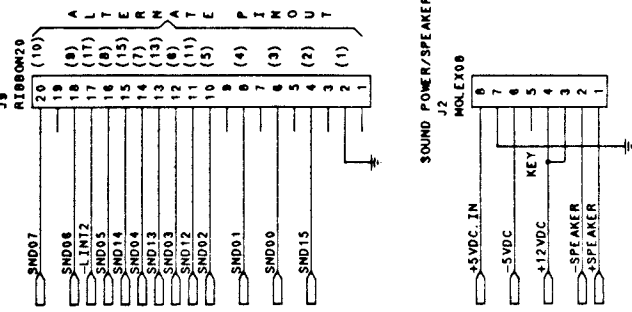

SOUND BOARD INTERFACE

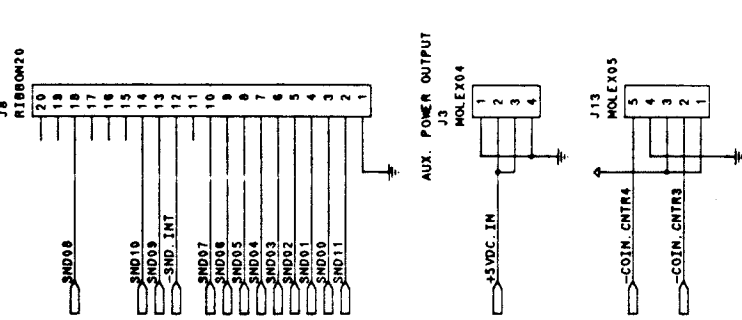

SOUND POWER/SPEAKER

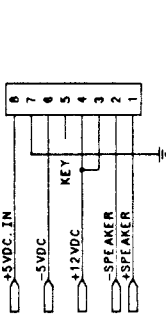

ADDITIONAL INPUTS

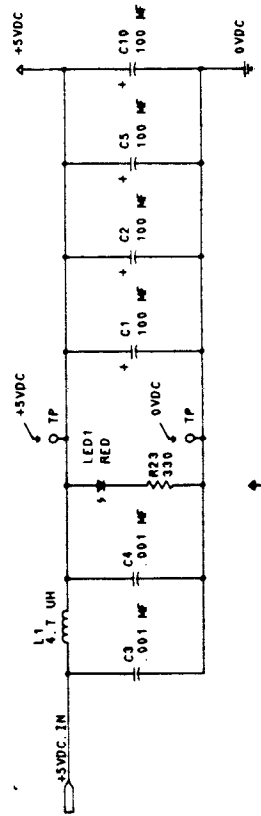
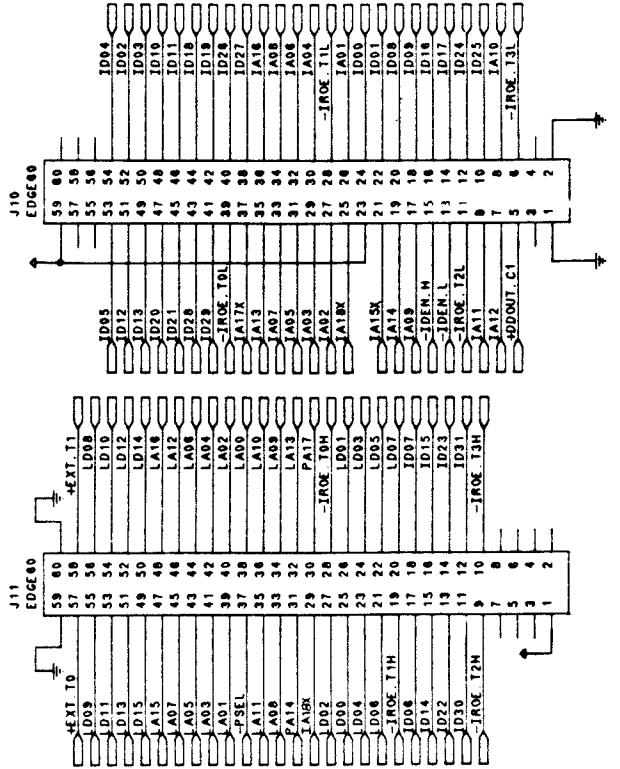
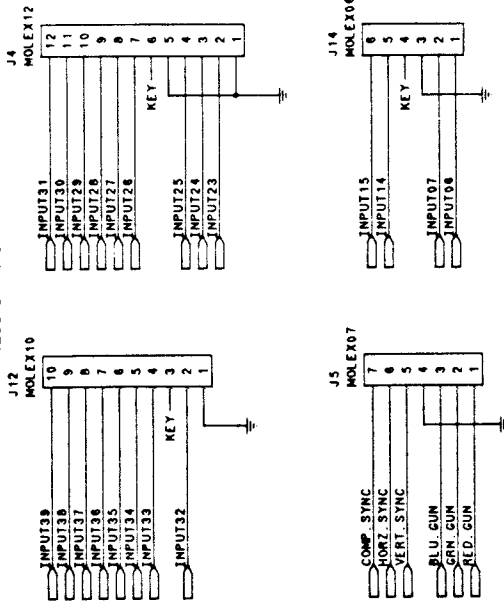

TROG CABINET WIRING

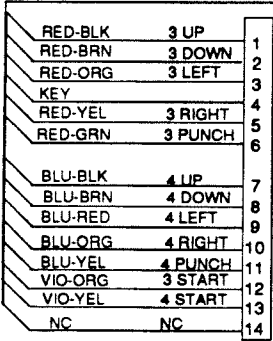
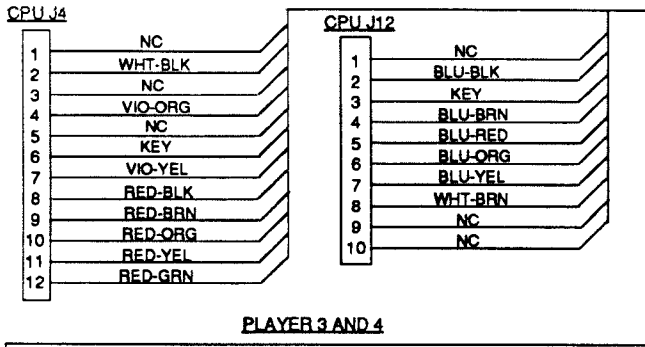

SEE CONTROL PANEL WIRING REFERENCE "A"

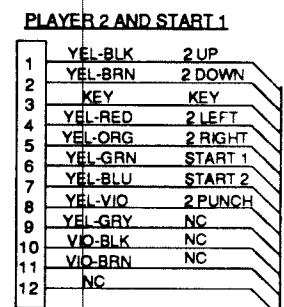
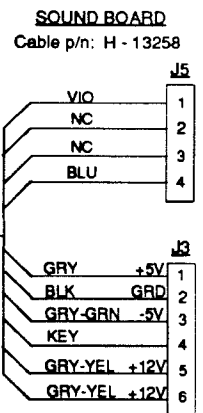
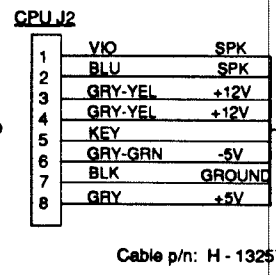
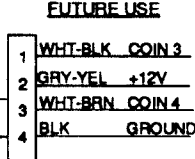
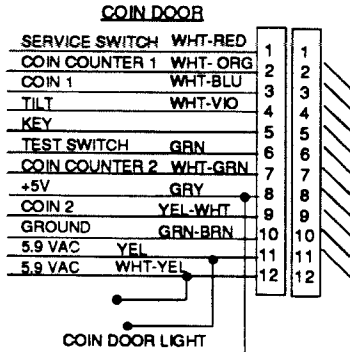

SEE CONTROL PANEL WIRING REFERENCE "B"

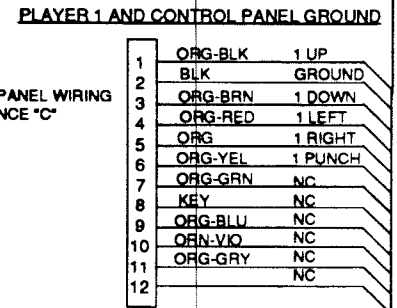

SEE CONTROL PANEL WIRING REFERENCE "C"

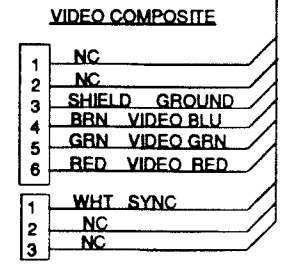
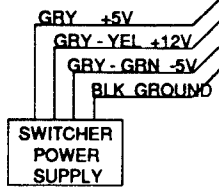
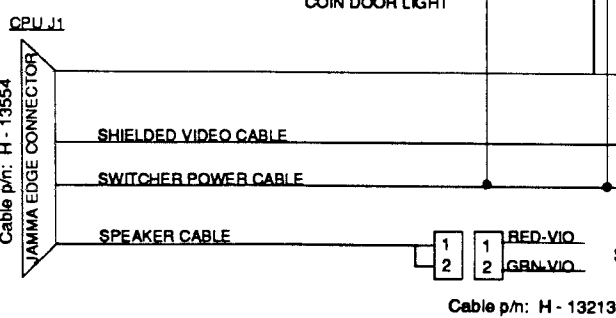

TROG CONTROL PANEL WIRING

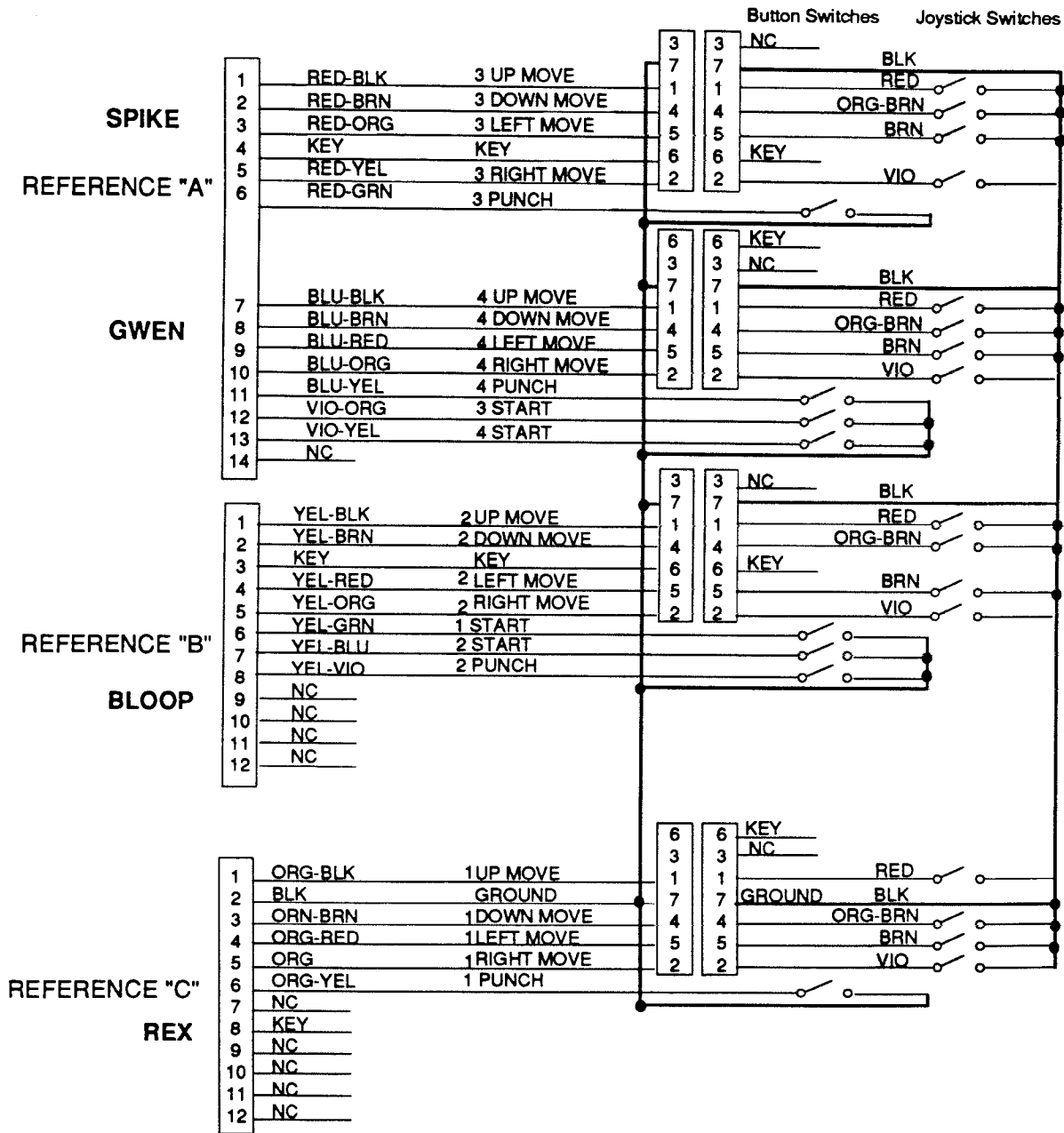

POWER WIRING DIAGRAM

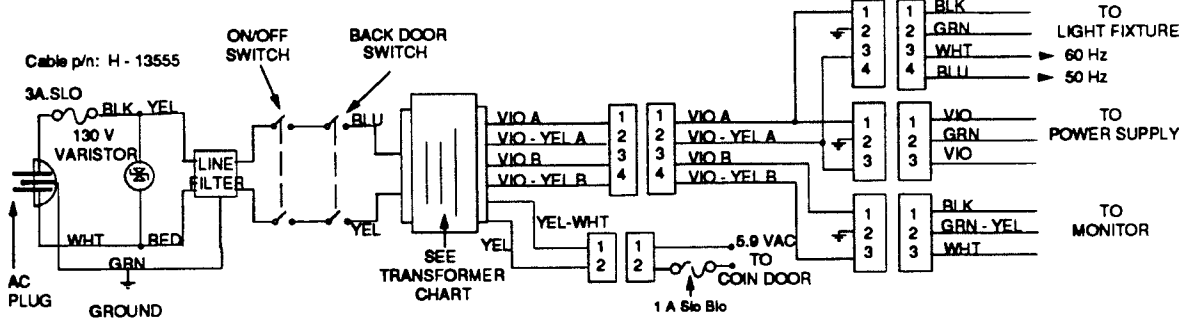

TRANSFORMER CHART

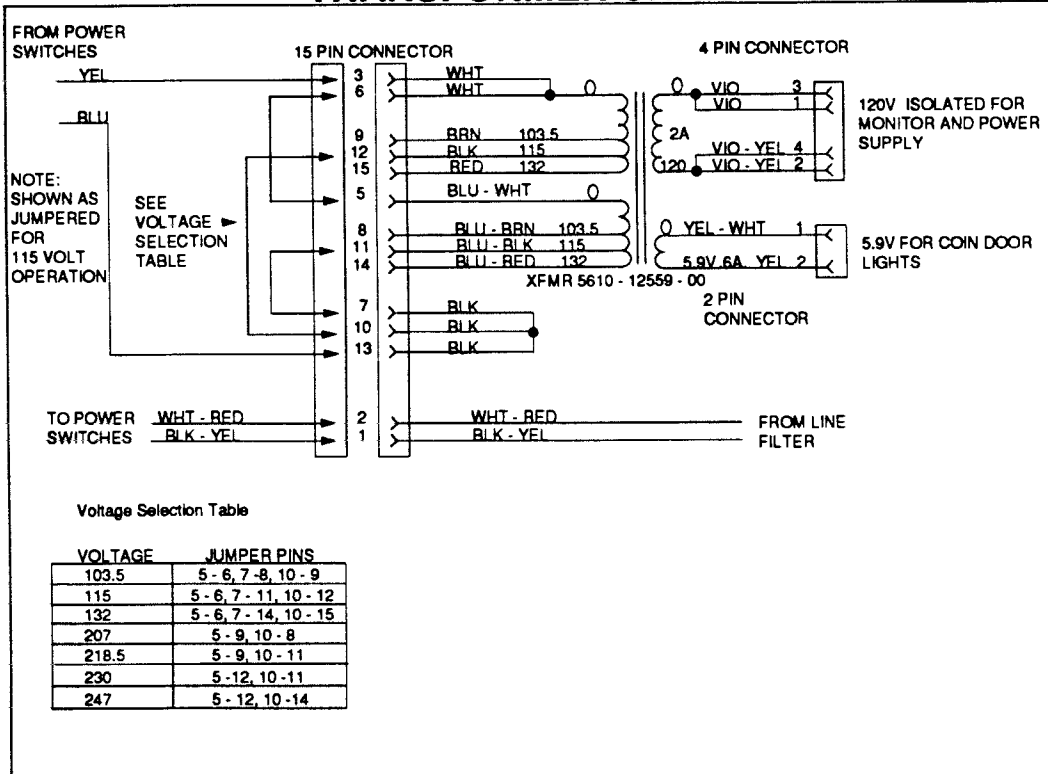

TROG INTERBOARD WIRING

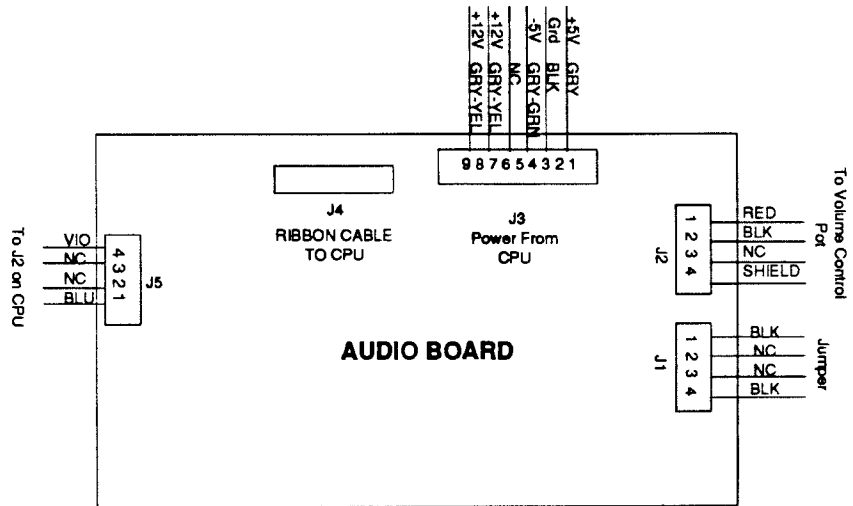
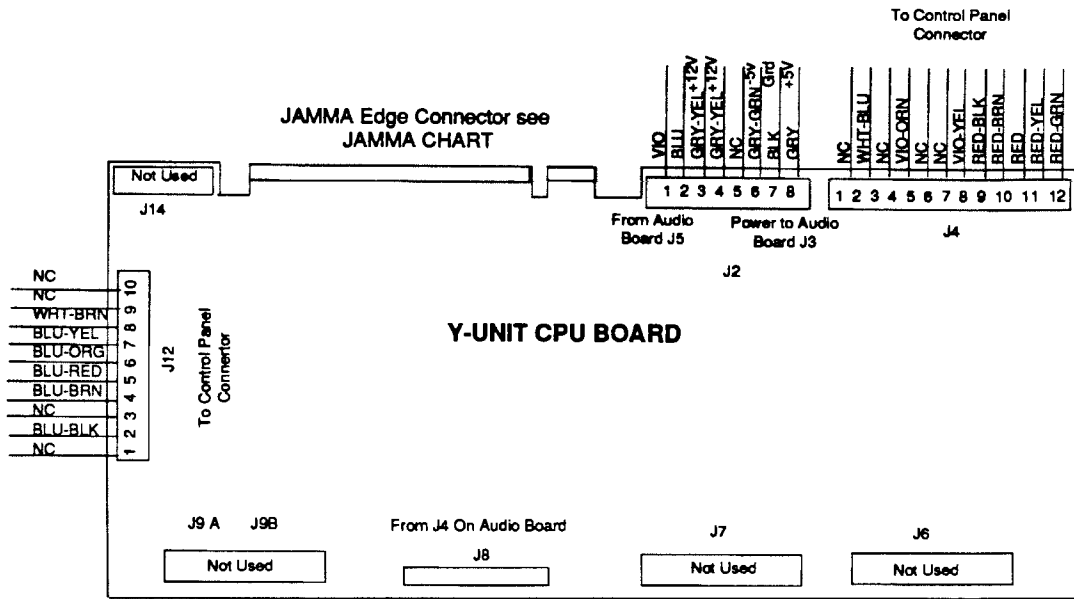

Control Panel Wire Colors

Rex

Up	Orange-Black
Down	Orange-Brown
Left	Orange-Red
Right	Orange
Start Button	Yellow-Green
Punch Button	Orange-Yellow
Ground	Black

Bloop

Up	Yellow-Black
Down	Yellow-Brown
Left	Yellow-Red
Right	Yellow-Orange
Start Button	Yellow-Blue
Punch Button	Yellow-Violet
Ground	Black

Spike

Up	Red-Black
Down	Red-Brown
Left	Red-Orange
Right	Red-Yellow
Start Button	Violet-Orange
Punch Button	Red-Green
Ground	Black

Gwen

Up	Blue-Black
Down	Blue-Brown
Left	Blue-Red
Right	Blue-Orange
Start Button	Violet-Yellow
Punch Button	Blue-Yellow
Ground	Black

WARNINGS & NOTICES

Warning

USE OF NON-MIDWAY PARTS OR CIRCUIT MODIFICATIONS MAY CAUSE SERIOUS INJURY OR EQUIPMENT DAMAGE! USE ONLY MIDWAY AUTHORIZED PARTS.

- * For safety and reliability, substitute parts and modifications are not recommended.
- * Substitute parts or modifications may void FCC type acceptance.
- * This game is protected by federal copyright, trademark and patent laws. Unauthorized modifications may be illegal under Federal law. This also applies to Midway logos, designs, publications and assemblies. Moreover, facsimiles of Midway equipment (or any feature thereof) may be illegal under federal law, regardless of whether or not such facsimiles are manufactured with Midway components.

Warning

This equipment generates, uses and can emit radio frequency energy and, if not installed properly and used according to the directions in this manual, may cause interference to radio communications. It has been tested and found to comply with the limits for a Class A computing device pursuant to Subpart J of part 15 of FCC rules which are designed to provide reasonable protection against such interference when operated in a commercial environment. Operation of this equipment in a residential area is likely to cause interference to radio communications, in which the user, at his or her own expense, will be required to take whatever measures may be needed to correct the interference.

Warning

When Midway ships a game, it is compliance with FCC regulations. The FCC Sticker is proof. If the sticker is missing or damaged, legal repercussions to the owner or distributor of the game may result. If your game does not contain an FCC Sticker, call Midway Manufacturing immediately.

Warning

Prevent shock hazard and assure proper game operation. Only plug this game into a properly grounded outlet. Do not use a cheater plug to defeat the power cord's grounding pin. Do not cut off the ground pin.

Notice

No part of this publication may be reproduced by any mechanical, photographic, or electronic process, or in the form of a phonographic recording, nor may be transmitted, or otherwise copied for public or private use, without permission from the publisher.

COPYRIGHT 1990 MIDWAY MANUFACTURING COMPANY ALL RIGHTS RESERVED

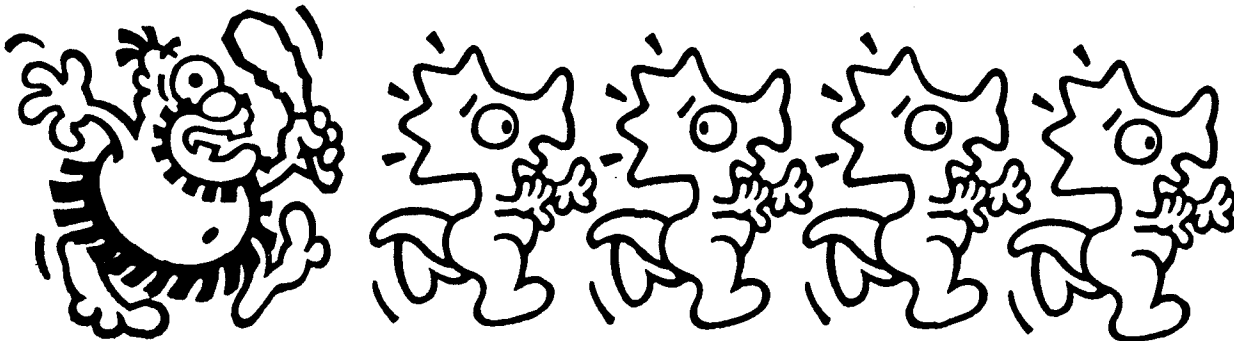

MIDWAY MANUFACTURING COMPANY
3401 N. CALIFORNIA AVE.
CHICAGO, ILLINOIS 60618