

SEGA

Title Fight

OWNER'S MANUAL

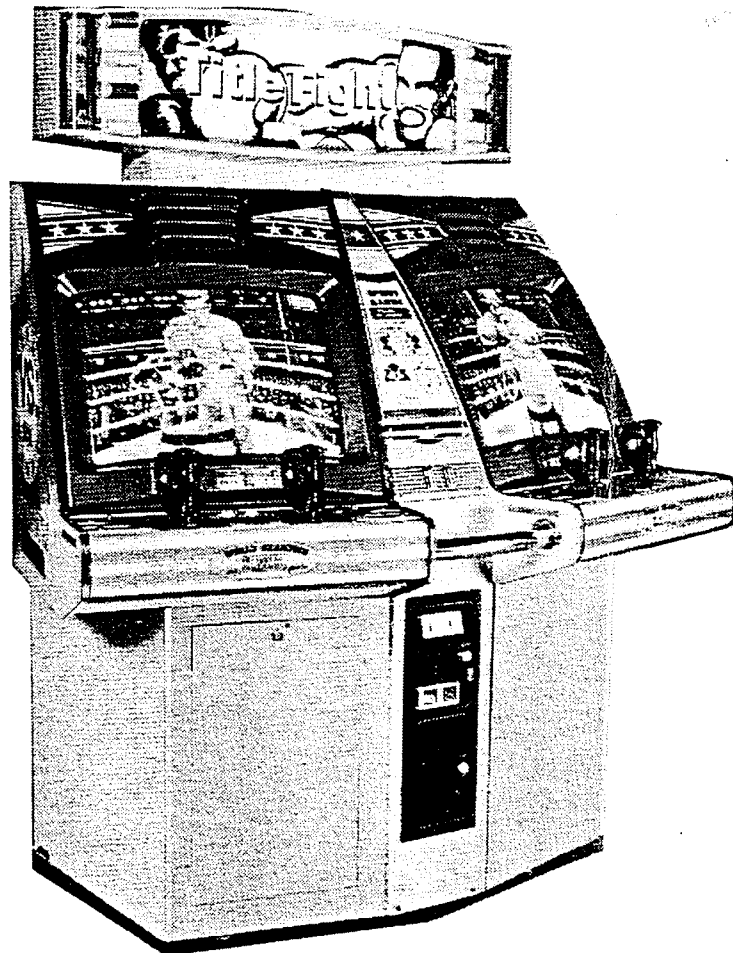

SEGA ENTERPRISES, LTD.

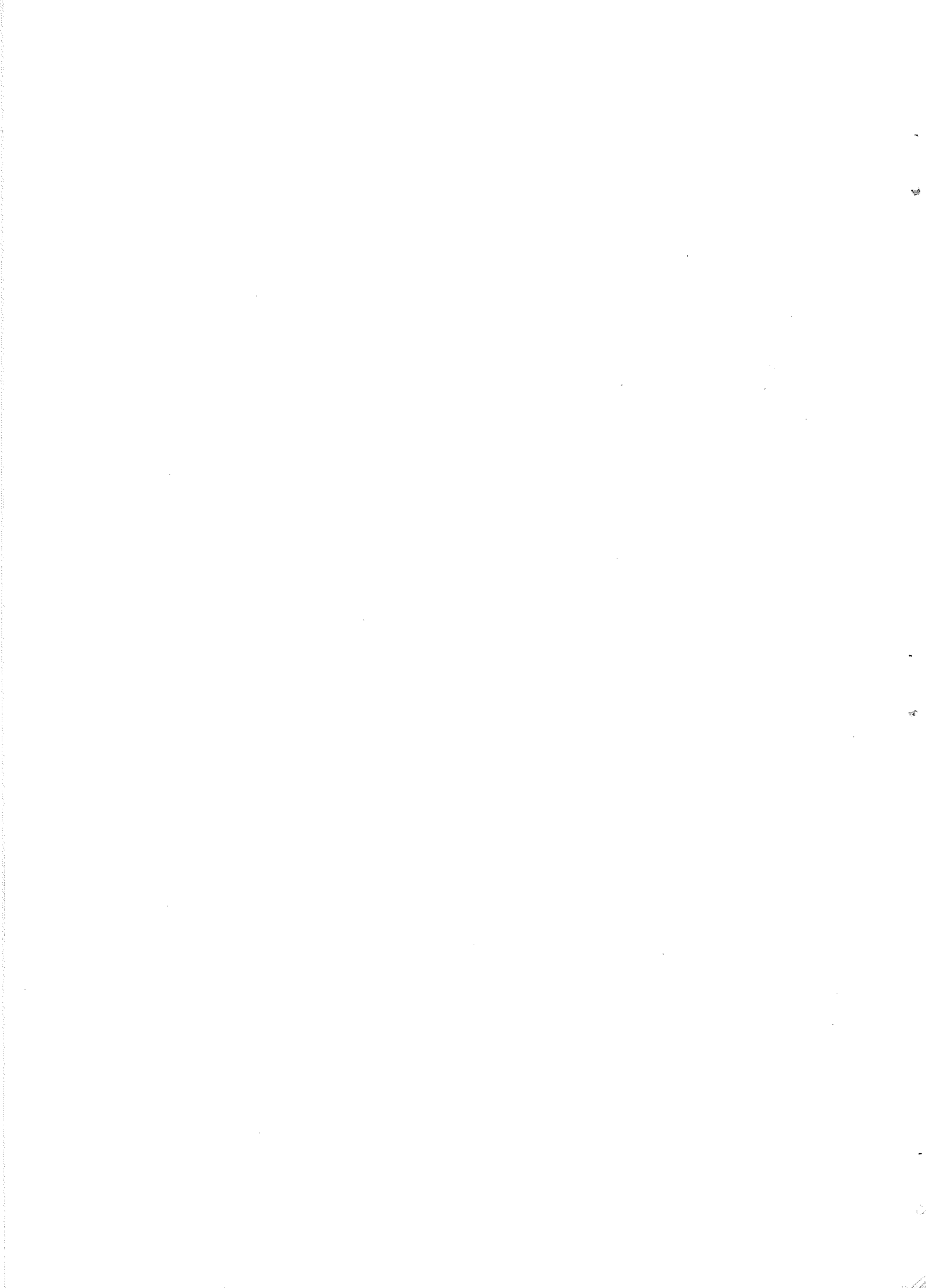

SEGA TITLE FIGHT

Built under license in the UK by Deith Leisure Limited

INTRODUCTION

This SEGA TITLE FIGHT is a revised version of the Japanese specification machine detailed in this manual. Some minor changes have been made to adapt the machine for the European market and some key components will be found to be different from those detailed in the original manual.

MODIFICATIONS

- Monitors - 2 x Wells-Gardner K7000 25" monitors
- Coin handling - Electronic: Coin Controls Sentinel C220 and Deith "Klingon" two player credit board with remote credit display
 - Mechanical: 2 x Coin Controls S10 mechanical coin validators
- Coin meters - one per coin mech mounted on vts bracket
- Switch bracket - modified to Deith Universal vts bracket
- Mains bracket - modified to Deith Universal multi-switch bracket incorporating: IEC inlet plug; 20mm 5A fuse; integral rfi filter; rocker switch and cherry switch
- Power supply - 15A switch mode power supply
 - toroidal multi-tapped transformer

The following pages have been intentionally omitted from this manual: 56; 57; 58; 59; 73; 74; 75.

Appendix (a) Wells-Gardner 25K7191 Schematic is found at the back of this manual

The basic operation of this machine remains as detailed in this manual.

BECAUSE OF THE NATURE OF THIS GAME IT IS ESSENTIAL THAT ALL FEET ARE PROPERLY ADJUSTED, THE SUB LEG BRACKETS ARE FITTED, AND THE STOPPER BRACKET IS FIXED CORRECTLY BEFORE ATTEMPTING TO PLAY THE MACHINE. (Refer to pages 6 & 7 for further information)

DEITH LEISURE LIMITED (April 1993)

This information is subject to change without notice

INTRODUCTION OF THE OWNER'S MANUAL

SEGA ENTERPRISES, LTD., supported by its high electronic technology of LSIs, microprocessors, etc. and a wealth of experience, has for more than 30 years been supplying various innovative and popular game machines to the world market. This Owner's Manual is intended to provide detailed descriptions together with all the necessary information covering the general operation of electronic assemblies, electromechanicals, servicing control, spare parts, etc. as regards TITLE FIGHT, a new SEGA product.

This manual is intended for those who have knowledge of electricity and technical expertise especially in ICs, CRTs, microprocessors, etc. Carefully read this manual to acquire sufficient knowledge before working on the machine. Should there be a malfunction, non-technical personnel should under no circumstances touch the interior system. Should such a case arise, contact our Main Office or the closest branch office listed as follows:

SEGA ENTERPRISES, INC. (U. S. A.)

45133 Industrial Drive, Fremont, California 94538, U. S. A.

Phone : (415) 802-3100

Fax : (415) 802-1754

SEGA AMUSEMENTS EUROPE LIMITED

Unit 2 Industrial Estate, Leigh Close, New Malden, Surrey KT3 3NL,
England

Phone : (081) 336-2256

Fax : (081) 336-1715

SEGA SOUTHERN EUROPE LIAISON OFFICE

Calle Vallelano, 19-23, 1° A, 37008-Salamanca, Spain

Phone : (923) 265893

Fax : (923) 265913

2. PREVENTION OF COUNTERFEITING AND CONVERSION

LABELLING

To prevent counterfeits and conversions, the following labels are put on all the SEGA products. When handling such goods, be sure to confirm the labels. They are used to prevent illegal acts such as the unauthorized copying of the products and the printed circuit boards thereof or carrying on business by manufacturing similar merchandise or by converting, selling or using such products or printed circuit boards.

ORIGINAL SEAL

The following seal is put on the machines manufactured by SEGA.

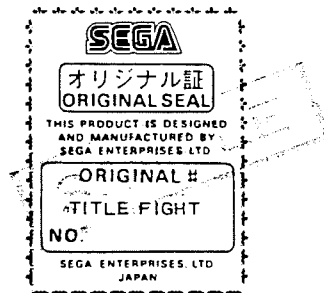

LICENSE SEAL

The following seal is put on all SEGA kits, such as the printed circuit boards.



COPYRIGHT NOTICE

This SEGA product has the copyright notice as follows:

© SEGA 1992

This signifies that this work was disclosed in 1992 and is the property of SEGA ENTERPRISES, LTD.

3. PRECAUTIONS CONCERNING INSTALLATION LOCATION

The TITLE FIGHT is an indoor game machine. Absolutely do not install it outside. Even indoors, avoid installing in places mentioned below so as to ensure proper usage:

- Places subject to rain or water leakage, or condensation due to humidity.
- In the proximity of an indoor swimming pool and/or shower.
- Places subject to direct sunlight.
- Places subject to heat sources from heating units, etc., or hot air.
- Vicinity of highly inflammable/volatile chemicals or hazardous matter.
- Sloped surfaces.
- Vicinity of anti-disaster facilities such as fire exits and fire extinguishers.
- Places subject to any type of violent impact.
- Dusty places.

INSTALLATION PRECAUTIONS

- 1) Do not insert more than one electrical plug into the power plug socket.
- 2) The per unit standard voltage/amperage is 200~240V/3A.
- 3) If an extension cord is to be used, use a cord of 7A or higher rating.

Electric current consumption

MAX. 1.55A (AC220V 50Hz)

MAX. 1.48A (AC220V 60Hz)

MAX. 1.41A (AC240V 50Hz)

MAX. 1.35A (AC240V 60Hz)

4. NAME OF PARTS

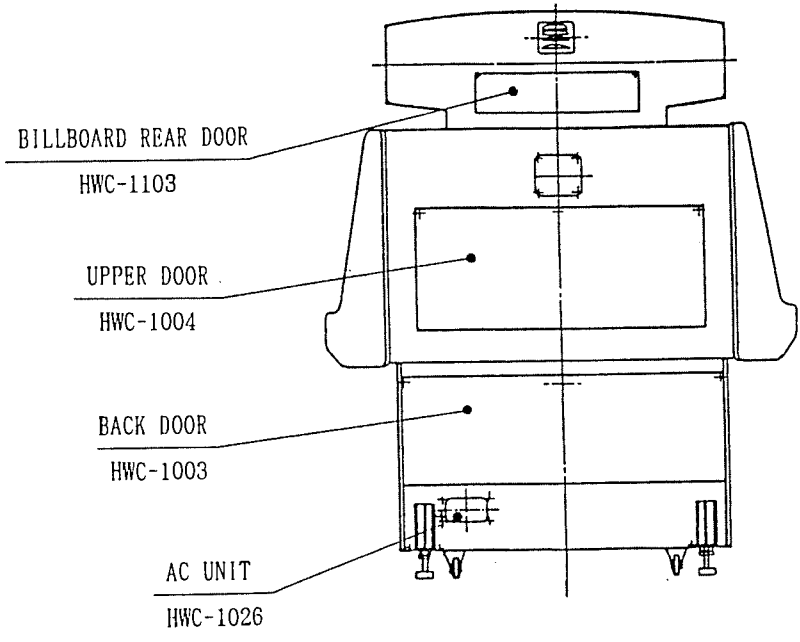
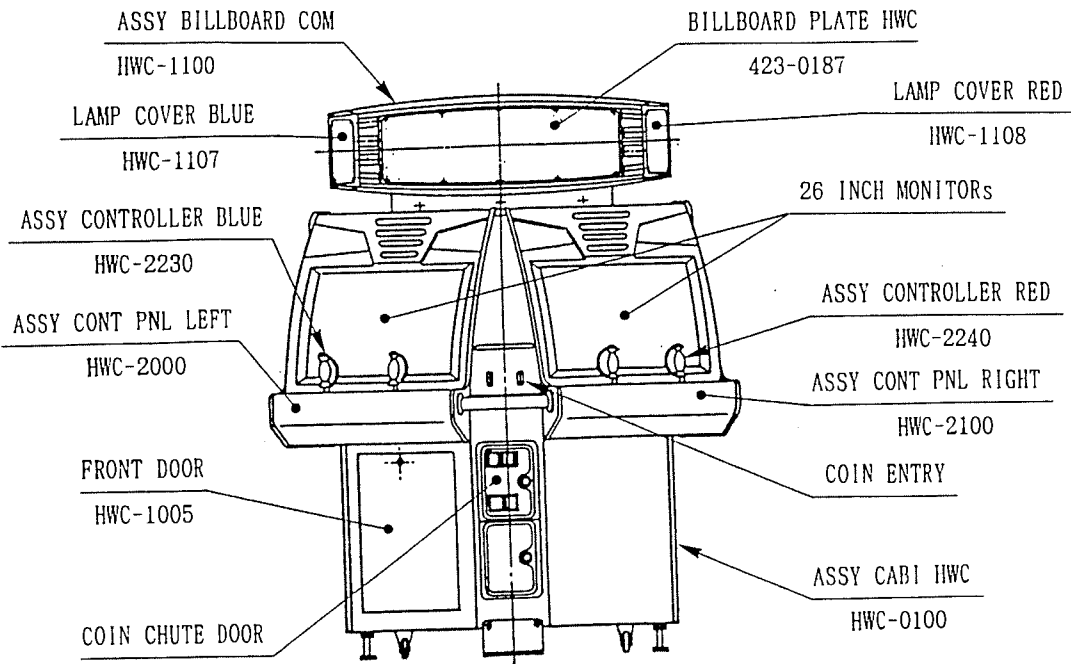

	Width×Depth×Height	Weight
Cabinet	1,710mm × 975mm × 1,618mm	181 kg.
Billboard	1,240mm × 200mm × 432mm	11 kg.
Complete Cabinet	1,710mm × 975mm × 2,042mm	192 kg.

5. ACCESSORIES

PART No.	Qty	DESCRIPTION	REMARKS
420-6071-01	1	OWNERS MANUAL TITLE FIGHT ENG	TITLE FIGHT OWNER'S MANUAL, ENG.
509-5466	2	SW MICRO TYPE (AM50033C5)	For spare
514-5036-5000	1	FUSE 6.4 ϕ \times 30 5000mA 125V	For spare
540-0006-01	1	WRENCH FOR TAMP PRF SCR DUAL TYPE M4	Tool
540-0007-01	1	WRENCH FOR TAMP PRF SCR DUAL TYPE M5	Tool
540-0009-01	1	WRENCH FOR TAMP PRF SCR DUAL TYPE M8	Tool
HWC-2014	2	CAP COVER RED	For spare
HWC-2015	2	CAP COVER BLUE	For spare
HWC-2215	2	RUBBER	For spare
220-5381	2	MASTER KEY	For opening/closing the doors
	2	KEY	For the CASHBOX DOOR
HWC-0001	2	SUB LEG BRACKET	
HWC-0004	1	STOPPER BRACKET	

TOOL

(TAMPERPROOF WRENCH)

M4 540-0006-01

M5 540-0007-01

M8 540-0009-01

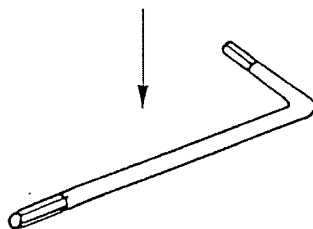

6. METHOD OF INSTALLATION AND ASSEMBLY

The following procedure applies when the disassembly of BILLBOARD is required for the installation of the machine.

- ① Take off the 2 SCREWS to remove the BILLBOARD's REAR DOOR.
- ② By using the 2 HEXAGON BOLTS from the inside of the BILLBOARD, secure the BILLBOARD and the CABINET.
- ③ Connect the 2 CONNECTORS.
- ④ Install the BILLBOARD's REAR DOOR by securing it with 2 SCREWS.

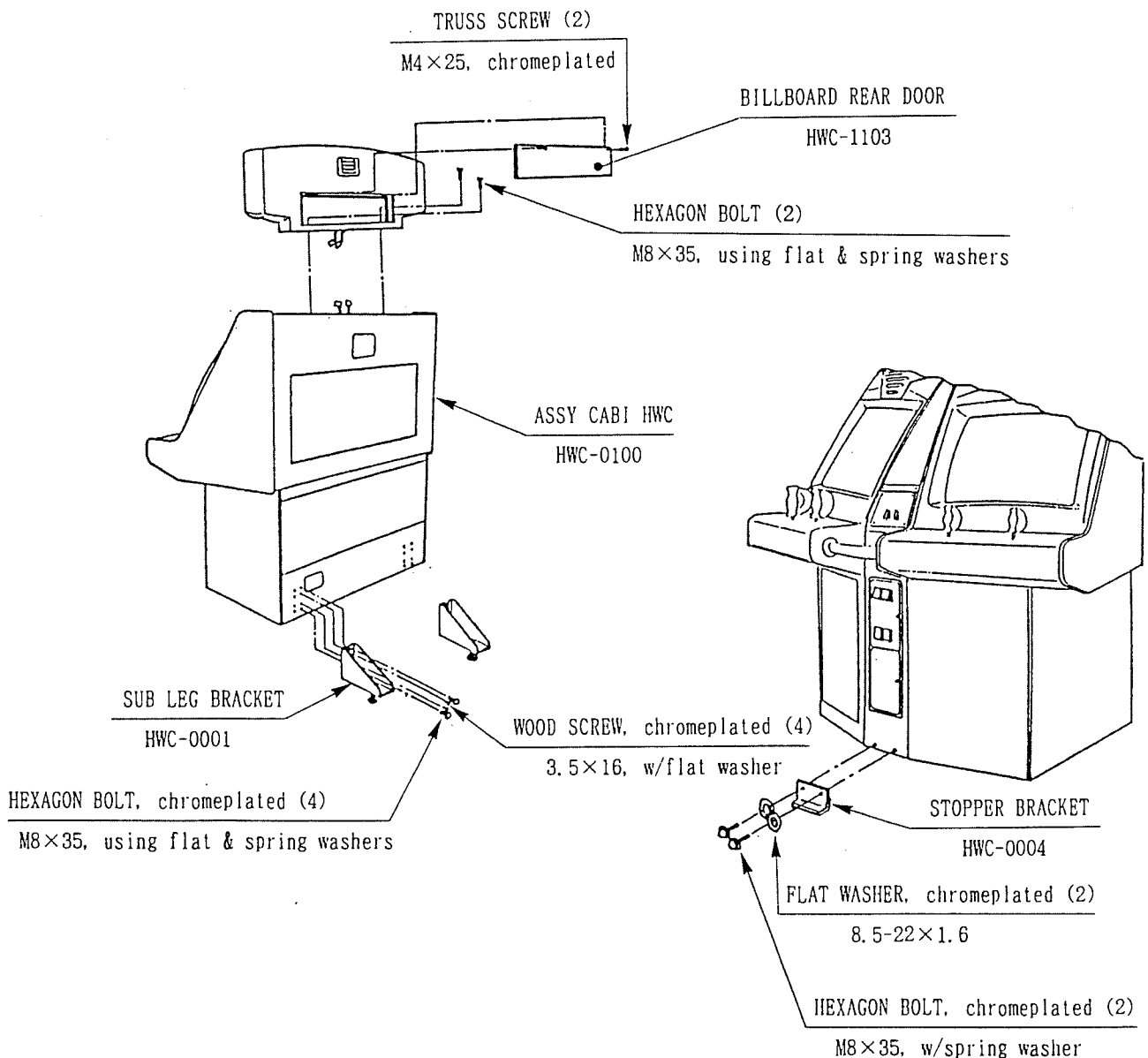

- ⑤ In a manner as shown, cause the 4 LEG ADJUSTERS (on the bottom of the cabinet) to come into contact with the floor and make sure that there is a gap of 5 mm between the casters and the floor, and that the cabinet is in level position.
- ⑥ Secure each of the 2 SUB LEG BRACKETs by using 4 BOLTS and 4 SCREWS.
- ⑦ Secure the STOPPER BRACKET with 2 BOLTS and 2 FLAT WASHERs.
- ⑧ Make sure that no LEG ADJUSTER is lifted above the floor. If any LEG ADJUSTER is lifted above the floor, cause it to make contact with the floor so that the cabinet can be adjusted to a level position.

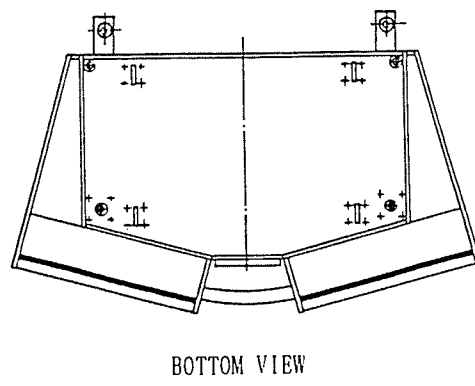
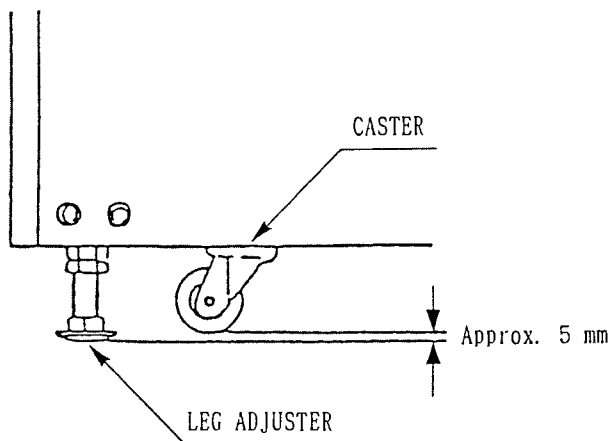

7. CONTROLLER

7-1 RUBBER REPLACEMENT (only when it is damaged)

- ① Take off the 7 TAMPERPROOF SCREWS which secure the CONTROL PANEL, and open the CONTROL PANEL.

NOTE : The torque required for fastening a TAMPERPROOF SCREW is 100 kgf·cm. (tightly fasten with a wrench and note that it should not be loosened by using a screwdriver).

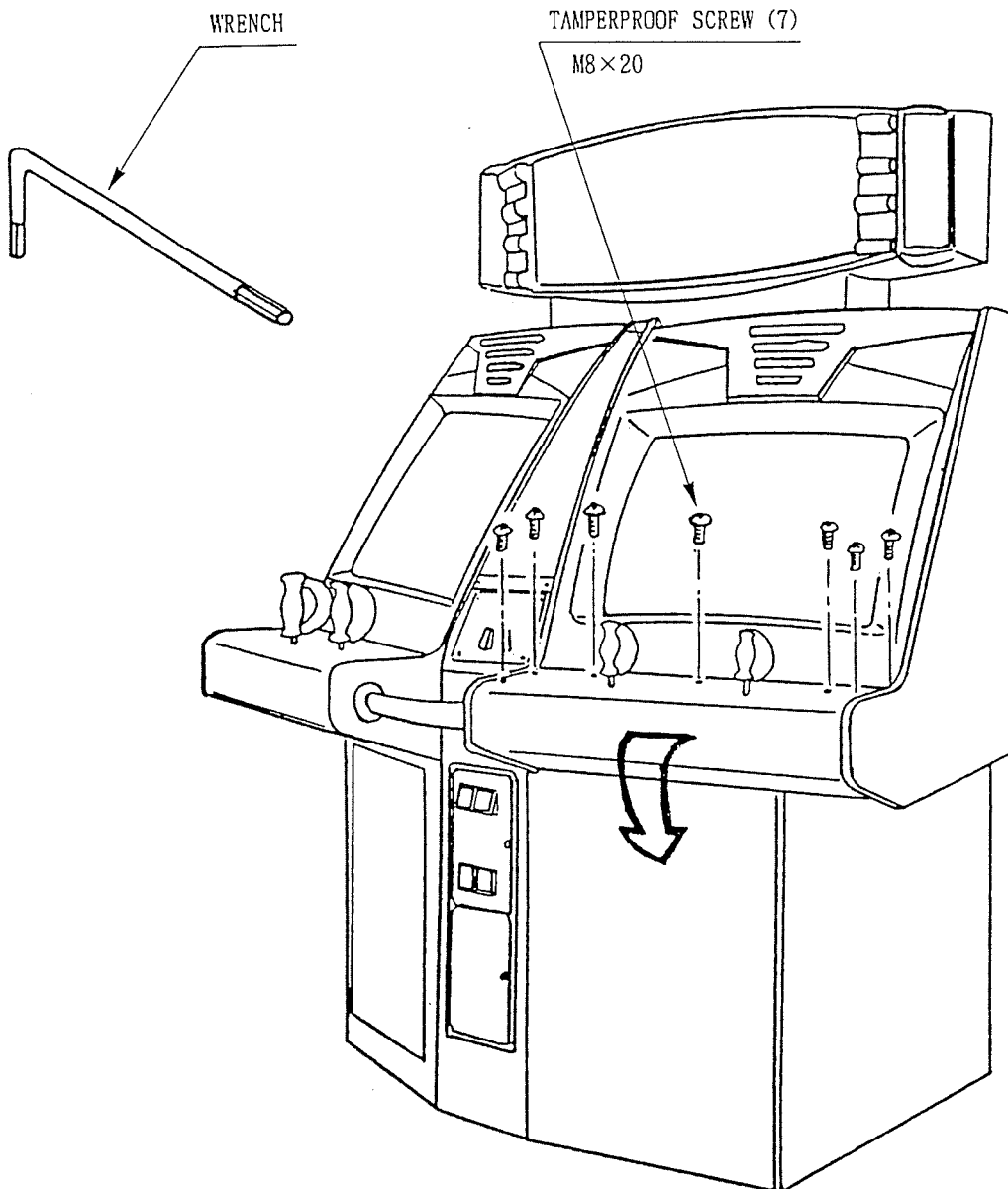

② Take off the SNAP RING from the SHAFT's end to replace the RUBBER.

CAUTION: Be very careful so that the sequential order of the FLAT WASHER and the SPACER should not be confused.

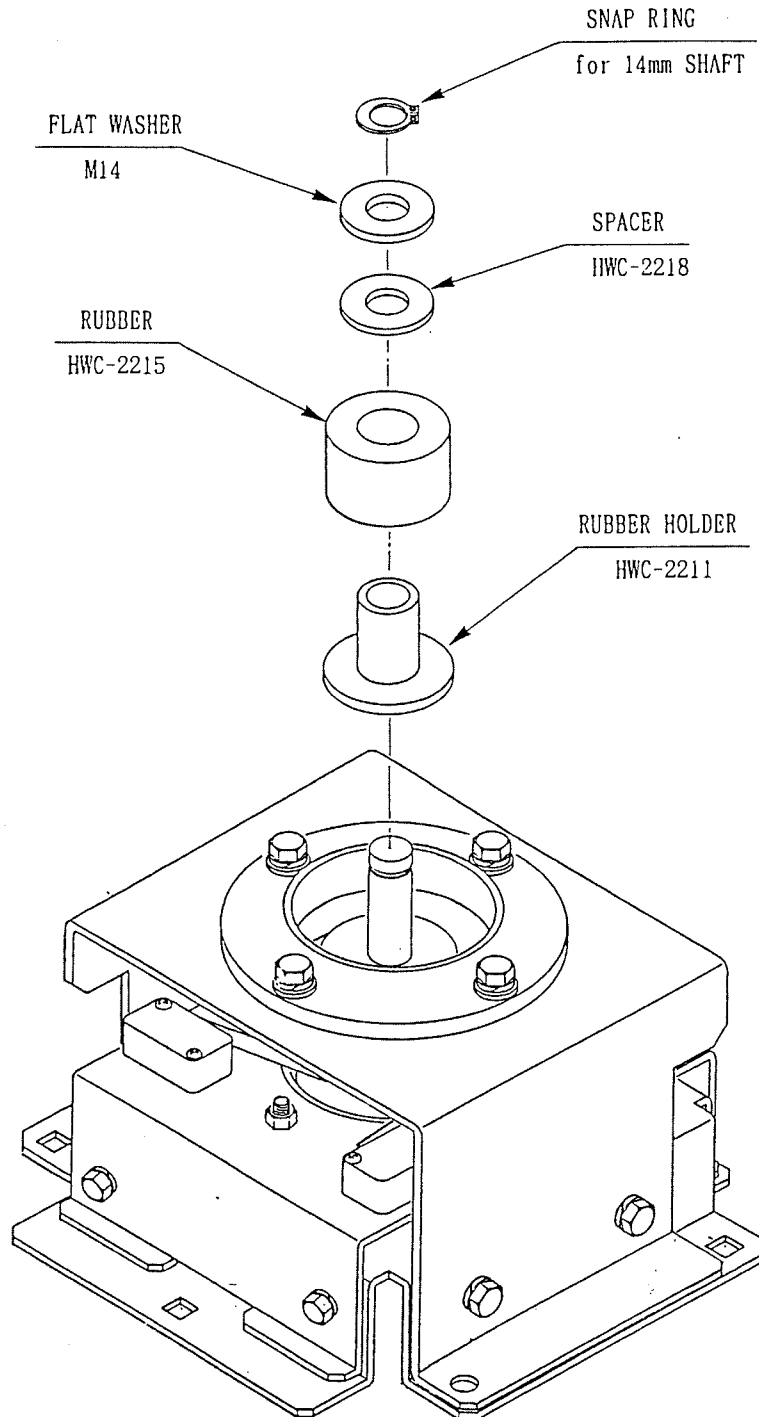

7-2 MICRO SWITCH REPLACEMENT

- ① From the CONTROL PANEL, take off the 4 HEXAGON BOLTS, 2 HEXAGON NUTS and 2 CARRIAGE BOLTS to remove the STOPPER BRACKET.
- ② Take off 2 SCREWS and replace the MICRO SW.

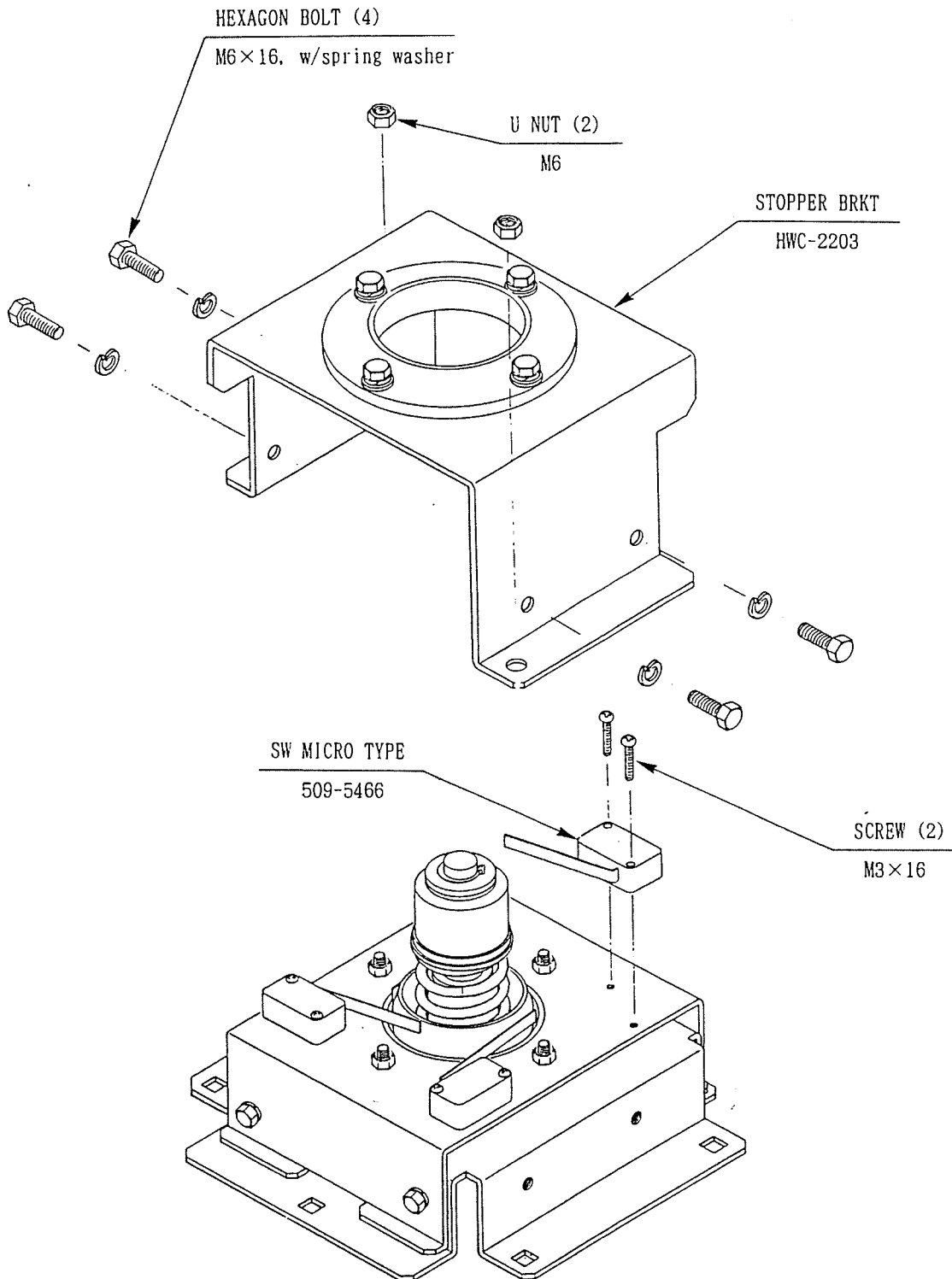

7-3 REMOVING THE CONTROLLER

- ① Take off the CAP COVER from the upper part of the GRIP, take out the TAMPERPROOF SCREW from the inside and remove the GRIP CAP.
- ② Take off the U NUT, GRIP, GRIP COVER and OUTER COVER.

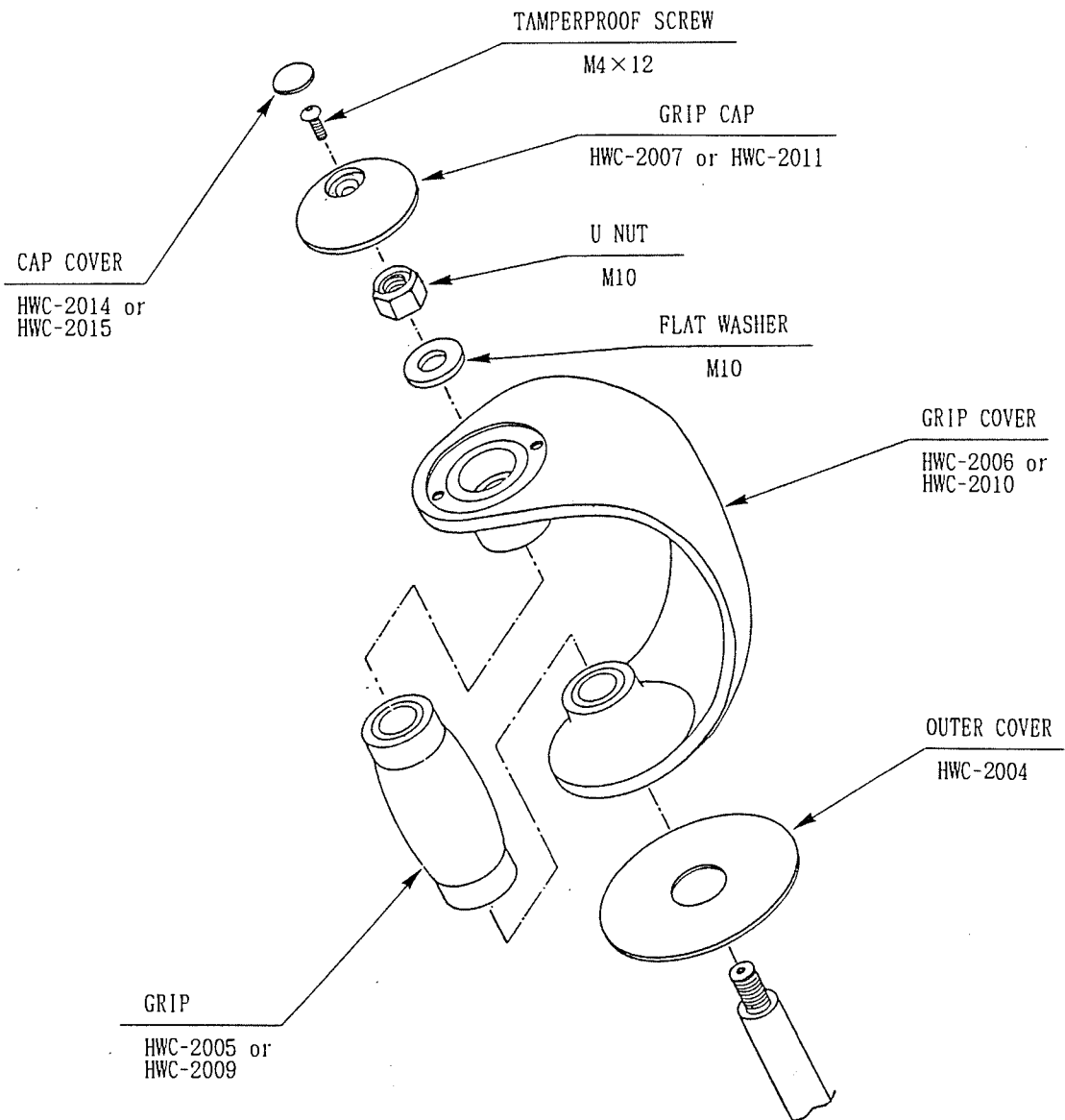

- ③ Take off the 5 HEXAGON NUTS which secure the CONTROLLER and remove the 5 CARRIAGE BOLTS.
- ④ Disconnect the CONNECTOR (white 6p) to enable the CONTROLLER to be removed from the CONTROL PANEL.

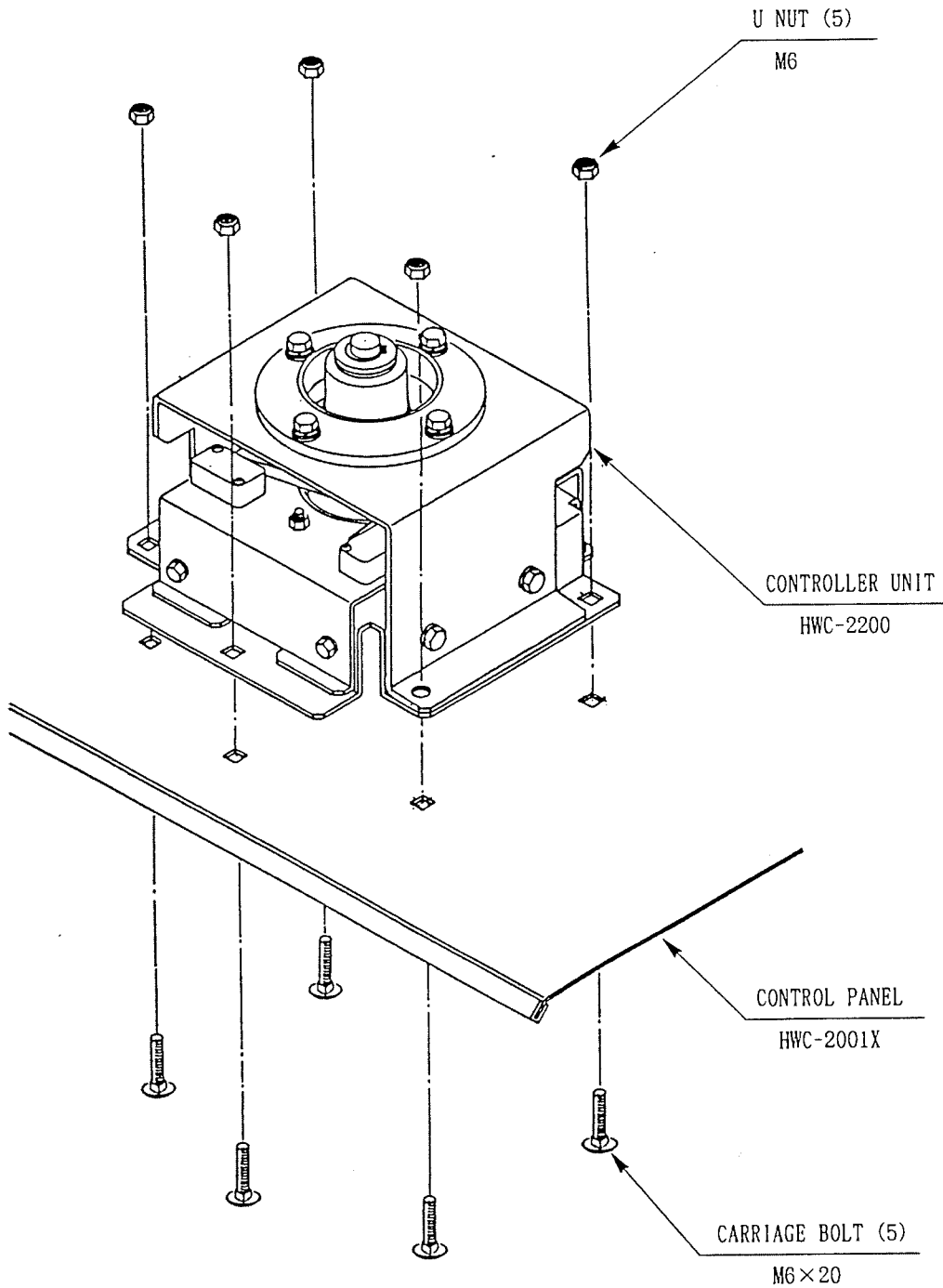

8. REPLACEMENT OF FLUORESCENT LAMP, AND LAMPS

In a manner as shown below, remove the parts and replace the Fluorescent lamp and Lamps.

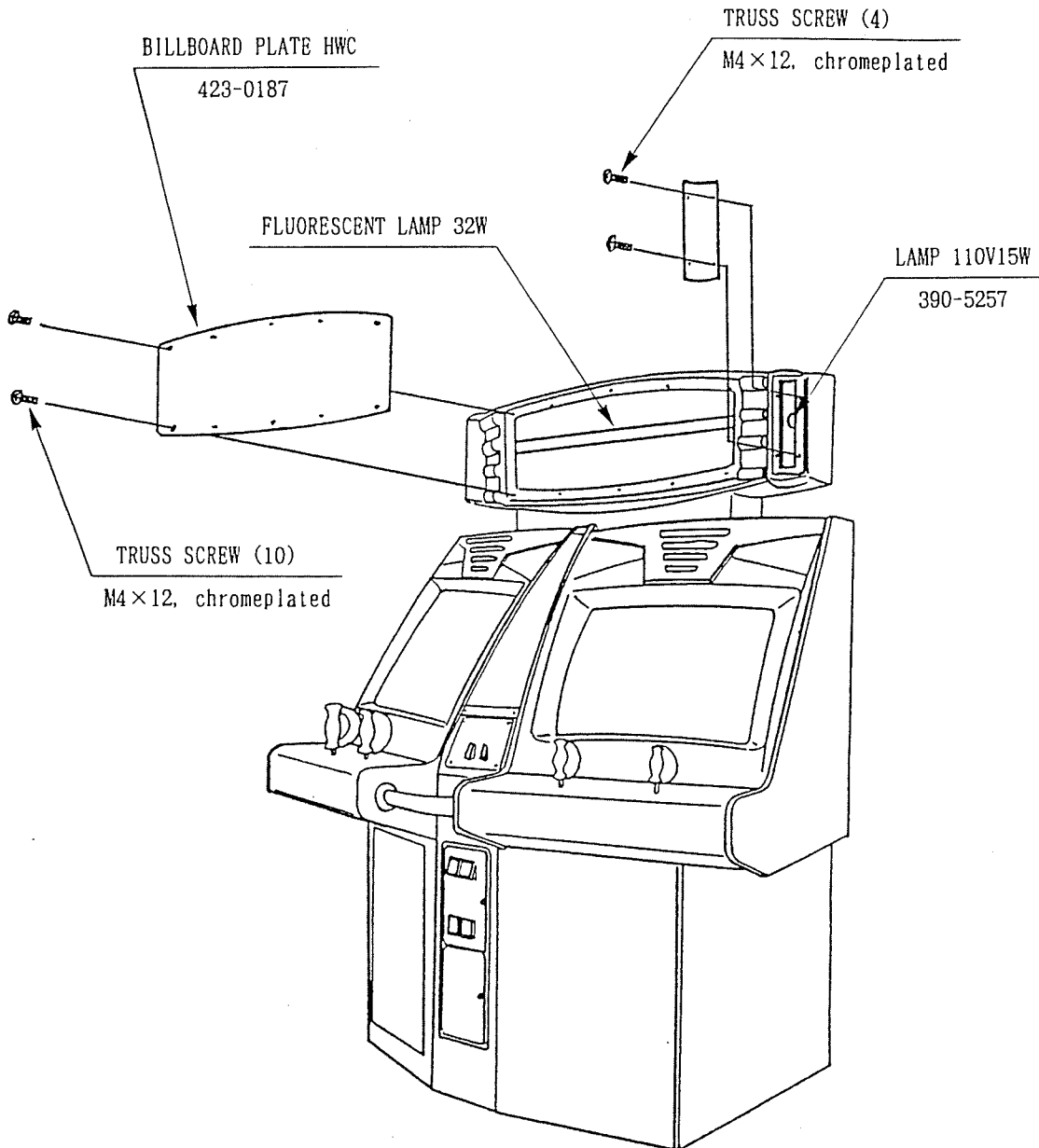

9. ADJUSTMENT OF THE 26" MONITOR

Do not operate the ADJUSTMENT knobs without good reason.

Also note that should any adjustment be required, first take off the 6 TAMPERPROOF SCREWS, remove the MASK HOLDER and FRONT MASK, then make adjustment.

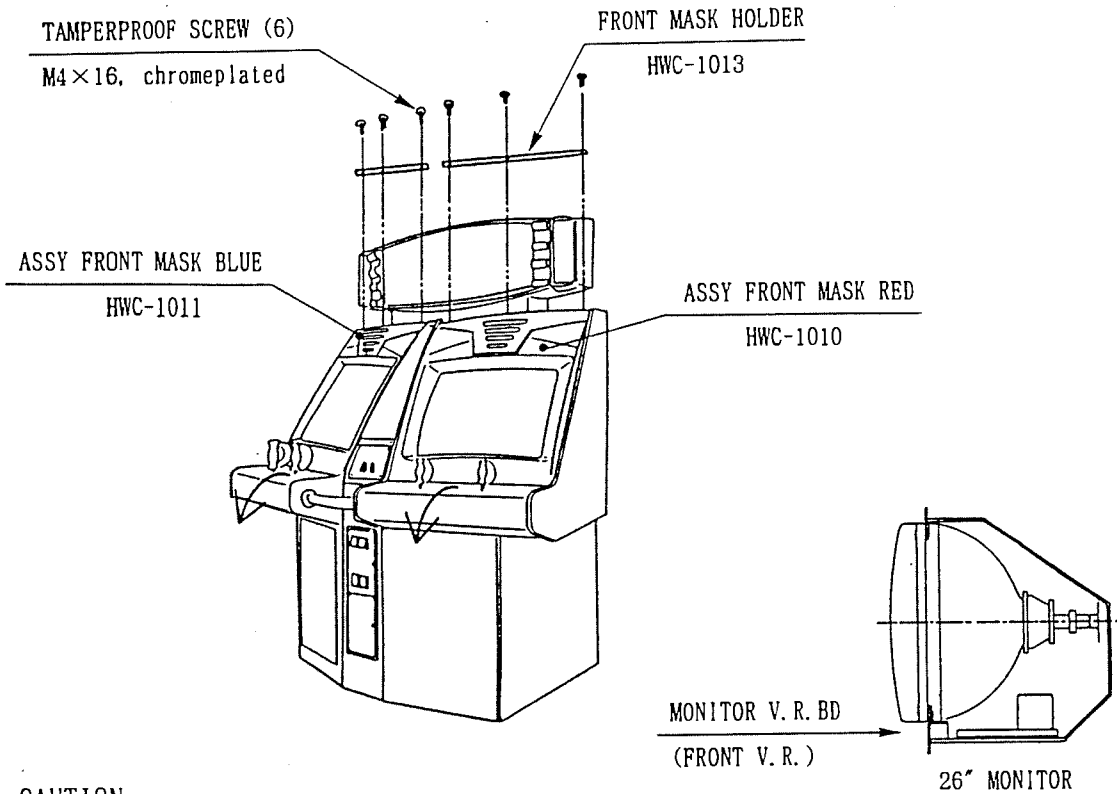

CAUTION

* A certain portion of the monitor is subject to a high voltage and therefore, be very careful of this point.

* When making adjustment, utilize a resinous Alignment Screwdriver.

THE PRISMATIC™

BY
WELLS-GARDNER

COLOR SPECIFICATIONS

CRT

- From 9" to 25" diagonal measure
- P22 phosphor
- Polished faceplate standard: variety of optional faceplates and transmittances available.
- Stripe trio spacings (standard): 0.62 mm (9"), 0.66 mm (13"), 0.82 mm (19"), 0.82 mm (25").
- Optional finer pitches available.

INPUT SIGNALS

- Video: RGB analog, 1v to 5v peak-to-peak (adjustable with contrast control), 4.7k ohm input impedance, 40 usec to 50 usec active video.
Optional inputs available:
- Negative video
- RGB analog 0-0.75v, 75 ohm input impedance
- Composite video (NTSC)
- Both composite video and RGB analog: Both signal sources can be connected to the monitor at the same time. Monitor display can be switched from one to the other, at anytime at pixel or vertical frame rate.
- Sync: TTL positive or negative going, separate or composite. Input impedance: 20K ohms for positive going sync; 12K ohms for negative going sync.

HORIZONTAL SCAN

- Width: Adjustable with just one coil to accommodate active video from 40 usec to 50 usec.
- Frequency: 15.1 kHz to 16.8 kHz standard; higher scan frequencies available.
- Linearity: $\pm 5\%$

PICTURE SIZE REGULATION

- 2%

VERTICAL SCAN

- Frequency: 47 Hz to 63 Hz
- Linearity: $\pm 5\%$

GEOMETRIC DISTORTION

- $\pm 2\%$ (max).

VIDEO CHARACTERISTICS

- Bandwidth (-3 db): 12 MHz typical
- Rise Time: Less than 50 nanoseconds
- Overshoot (max): 5%

MECHANICAL

- The 19" monitor is also available in universal mount brackets. The monitor can be mounted in the user's cabinet horizontally or vertically. Contact your sales representative for details.
- The standard Prismatic-25™ 25" monitor is available as a kit - without a frame. Custom frames can be furnished.
- The standard Prismatic-9™ 9" monitor is available as a kit - without a frame: Also available in chassis form - adaptable to individual customer requirements.
- Contact your sales representative for details.

USER ADJUSTABLE CONTROLS AND ADJUSTMENTS

- Brightness, Contrast, Horizontal Hold, Horizontal Size, Horizontal Raster Position, Horizontal Video Position, Vertical Hold, Vertical Size, Vertical Raster Position, Focus. Custom Control Location available.

POWER INPUT

- 120 VAC +10% -15%, 50-60 Hz, 85W (max). Isolation transformer required; furnished with monitor as an option.

ENVIRONMENTAL CONDITIONS

- Operating temperature 0° to 55°C. Complies with U.L., C.S.A., and D.H.H.S. radiation performance standard (composite video).

RESOLUTIONS

- | | |
|----------------------------|------------------------|
| • Standard CRT | • Fine Pitch CRT |
| 9" 280 Pixels x 240 Lines | 410 Pixels x 240 Lines |
| 13" 400 Pixels x 240 Lines | 640 Pixels x 240 Lines |
| 19" 400 Pixels x 240 Lines | 640 Pixels x 240 Lines |
| 25" 560 Pixels x 240 Lines | N. A. |

**** SPECIFICATIONS ARE SUBJECT TO CHANGE IN ORDER TO ASSURE YOU THE LATEST IN DISPLAY TECHNOLOGY.****

USER ADJUSTMENTS

1. BRIGHTNESS CONTROL VR6

This control has been preset at the factory. However, when the video signal is applied to the monitor, a slight adjustment may be desired. Adjust this control such that the illumination is just barely extinguished from portions of the display which should be black.

2. CONTRAST CONTROL VR7

Adjust the contrast control for the desired picture intensity.

3. FOCUS CONTROL

Adjust the focus control, located on the high voltage unit (T1), for maximum over-all definition and fine picture detail.

4. HORIZONTAL HOLD CONTROL VR2

With the monitor being driven with the display signal, connect one jumper between TP1 and TP2 and another jumper between TP3 and TP4. Adjust the horizontal hold control until the picture stops sliding horizontally. Remove the jumpers. Do not use the horizontal hold control for horizontal centering. (See #5).

NOTE: If the sync signal is composite, use the horizontal sync input of the same polarity as the composite sync signal.

5. HORIZONTAL VIDEO SHIFT CONTROL VR1

Use this control to center the picture horizontally.

6. HORIZONTAL RASTER POSITION ADJUSTMENT

If the picture is off center horizontally (long dimension of picture tube), some compensation can be made by moving the horizontal raster position adjustment jumper either to positions "R" or "L".

7. HORIZONTAL SIZE COIL L1

The horizontal size coil is a hexagonal tuning tool adjustment. This control must be adjusted slowly, if necessary, until the picture or test pattern attains the correct horizontal proportions.

8. VERTICAL HOLD CONTROL VR5

Adjust this control until the picture stops rolling and it locks in vertically.

9. 50-60 Hz CONTROL VR9

This control is used to limit the range of vertical size. This control is preset at the factory and should not require re-adjustment unless the vertical size control or vertical hold control are readjusted from their original factory settings. In order to set this control, first adjust the vertical size control so that the picture is slightly larger than desired. Turn VR9 so that any vertical foldover which may be present will disappear. If the monitor is to be operated alternately at more than one vertical frequency, then perform this adjustment at the higher frequency.

10. VERTICAL SIZE CONTROL

This control must be adjusted slowly, if necessary, until the picture or test pattern attains the correct vertical proportions.

11. VERTICAL RASTER POSITION CONTROL VR3

If the video is off center vertically, (short dimension of picture tube) some compensation can be made by turning the vertical raster position control.

12. CUT OFF AND DRIVE CONTROLS ON NECK BOARD VR201, VR202, VR203, VR204, VR205, VR206.

These controls have been preset at the proper gray scale. Before adjusting any of these controls, refer to Troubleshooting Note 4 and to the White Balance procedure.

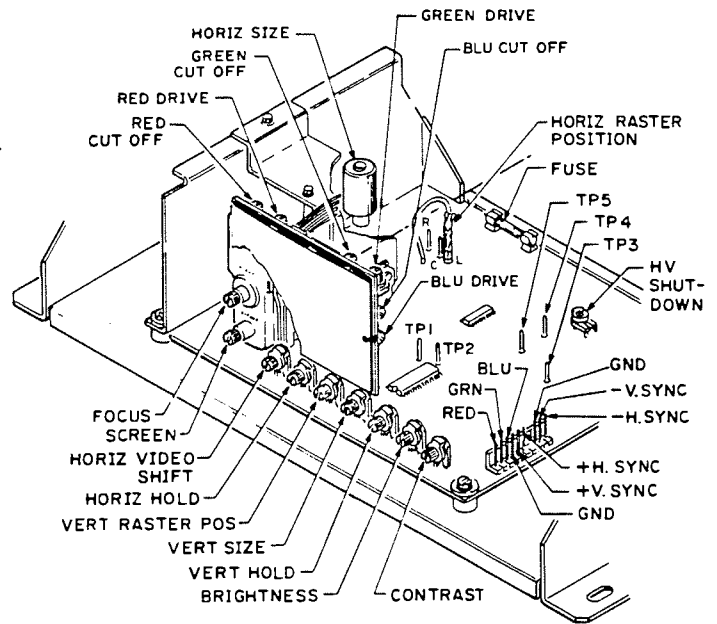

FIG. 1A

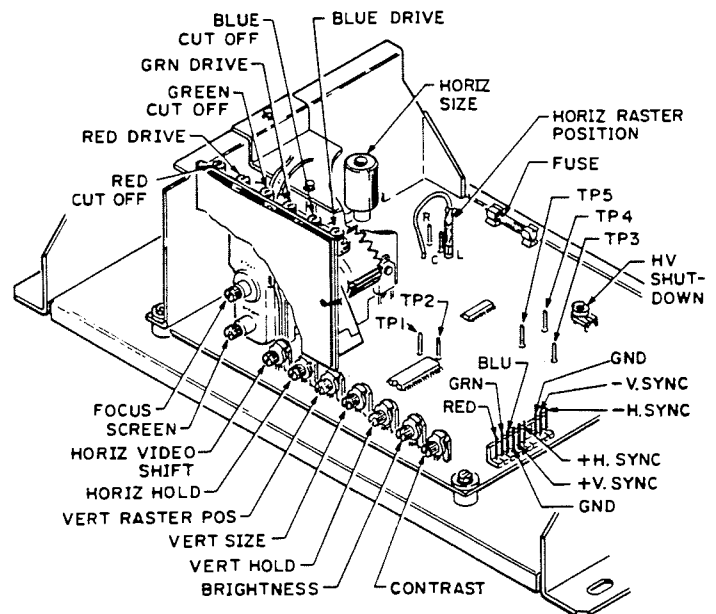
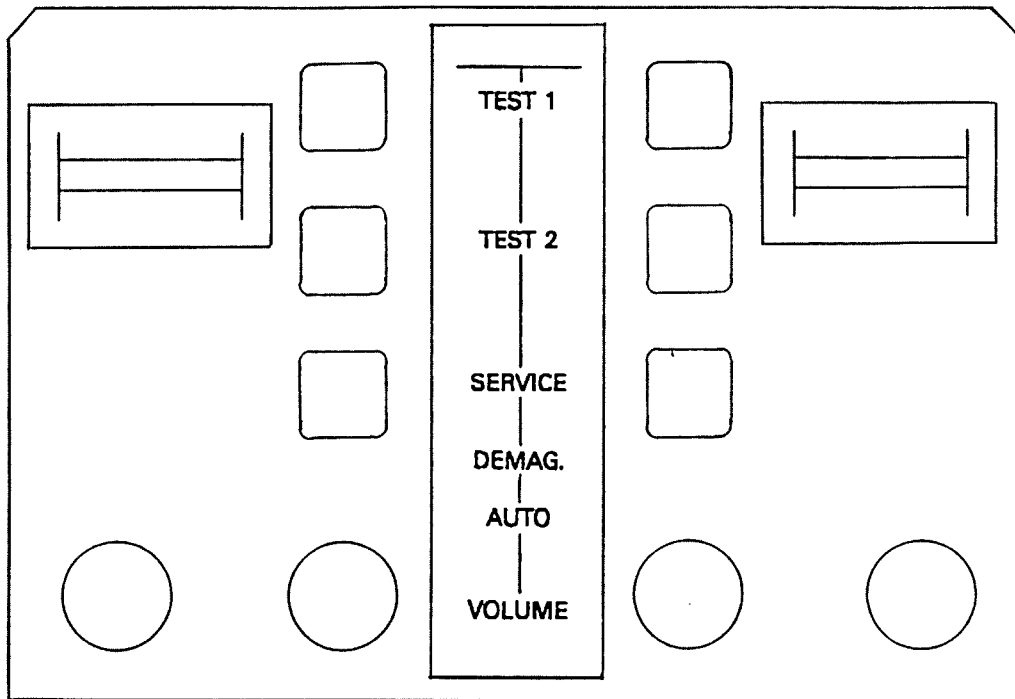

FIG. 1B

10. DESCRIPTION OF SW UNIT

Open the coin chute door and you will see the switch unit as shown in the photo.



- TEST BUTTON : For the handling of the test button, refer to the section on test mode.
- SERVICE BUTTON : Gives credits without registering on the coin meter.
- DEMAGNETIZER SWITCH : Eliminates color unevenness from the screen.
- VOLUME CONTROL : Controls the speaker volume.

11. TEST MODE

This mainly checks if the operation of the game BD is accurate, and allows for COIN ASSIGNMENTS/GAME ASSIGNMENTS setting adjustments.

Also, monitor color adjustments can be made in this mode.

The screen displays and operation (moves) are identical on both of the monitors. The TEST and SERVICE buttons function for both the left and right monitors in the same manner.

Selection of TEST ITEMS

1) Push the TEST SW to cause the following TEST ITEM MENU to appear:

```
TEST MENU
INDIVIDUAL
MEMORY TEST
INPUT TEST
SOUND TEST
C. R. T. TEST
GAME ASSIGNMENTS
COIN ASSIGNMENTS
BOOKKEEPING
BACKUP DATA CLEAR
OUTPUT TEST
→ EXIT
SELECT BY SERVICE BUTTON
AND PUSH TEST BUTTON
```

- 2) By pushing the SERVICE SW, bring the arrow mark "→" to the desired item and press the TEST button.
- 3) When the test has been completed, bring "→" to EXIT and push the TEST button.

Bring "→" to "INDIVIDUAL" and push the TEST button to change it to "CONTINUE."

Bringing "→" to "CONTINUE" and pushing the TEST button without pressing the SERVICE button will change the screen sequentially.

When "INDIVIDUAL" is selected, only the item pointed by "→" is tested.

① MEMORY TEST

Check the PCB's MEMORY ICs.

Entering this test mode causes the test to be executed automatically.

Once the test begins, you can not exit from the test until it is finished.

During the test, irregular status may appear on the screen. However, this is not malfunctioning. The test time required is approximately 45 seconds. If the irregular status continues in excess of this period, it may be considered some sort of malfunctioning.

Upon completion of the test, "GOOD" will be displayed for the normal IC's and "BAD" will be displayed for the malfunctioning IC's.

MEMORY TEST					
<ROM>					
IC39	GOOD	IC40	GOOD		
<RAM>					
IC1	GOOD	IC2	GOOD	IC3	GOOD
IC4	GOOD	IC21	GOOD	IC54	GOOD
IC57	GOOD	IC58	GOOD	IC60	GOOD
IC61	GOOD	IC67	GOOD	IC68	GOOD
IC70	GOOD	IC115	GOOD	IC116	GOOD
IC117	GOOD	IC118	GOOD	IC120	GOOD
IC121	GOOD	IC122	GOOD	IC123	GOOD
PUSH TEST BUTTON TO EXIT					

Push the TEST button to have the MENU return on to the screen.

② INPUT TEST

This test displays the state of each switch.

If the switch goes ON when activated, it is satisfactory.

INPUT TEST					
	BLUE		RED		
	LEFT	RIGHT	LEFT	RIGHT	
UP	OFF	OFF	OFF	OFF	— (A)
DOWN	OFF	OFF	OFF	OFF	— (B)
RIGHT	OFF	OFF	OFF	OFF	
LEFT	OFF	OFF	OFF	OFF	
	BLUE		RED		
START-1P	OFF		OFF		— (C)
START-2P	OFF		OFF		— (D)
SERVICE	OFF		OFF		— (E)
TEST	OFF		OFF		— (F)
COIN	OFF		OFF		— (G)
PUSH TEST BUTTON TO EXIT					

- (A) BLUE The left side Player
- RED The right side Player
- (B) LEFT The left-hand side controller of each control panel
- RIGHT The right-hand side controller of each control panel
- (C) START-1P ... START button for 1P
- (D) START-2P ... START button for Player vs. player
- (E) SERVICE SERVICE BUTTON
- (F) TEST TEST BUTTON
- (G) COIN COIN SWITCH

Push the TEST button to have the MENU return on to the screen.

③ SOUND TEST

This allows sound used in the game to be tested.

Pressing the SERVICE BUTTON increases the number by one and changes the sound.

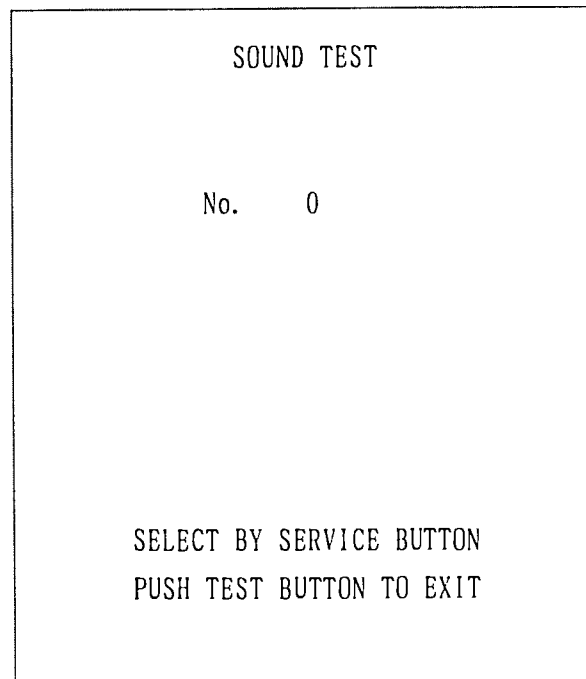

Push the TEST button to have the MENU return on to the screen.

(B) MONITOR FLIP

Determines whether the screen is to be reversed or not.

Setting is made either to NORMAL or REVERSE.

(The standard setting is made to NORMAL.)

(C) ADVERTISE SOUND

Determines whether ADVERTISE SOUND is to be emitted or not by setting to ON when emitting it and to OFF when not emitting it.

(set to OFF in the standard setting).

(D) GAME TIME (1P)

Determines the actual time corresponding to the 1 ROUND 3 minutes virtual time for 1P mode. The actual time is set between a maximum of 3M00S and a minimum of 1M00S in 5 steps in increments of 30 seconds (the standard setting is made to 1M00S).

(E) GAME TIME (VS)

Determines the actual time corresponding to the 1 ROUND 3 minutes virtual time for Player vs. Player mode. The actual time is set between a maximum of 3M00S and a minimum of 1M00S in 5 steps in increments of 30 seconds (the standard setting is made to 1M30S).

(F) BREAK INTO

Determines whether Buy-in competition is allowed or not. Set to ON when it is allowed and to OFF when not allowed. (The standard setting is made to ON.)

The mode enables the winner to unconditionally continue the game. However, in the case of a draw, both of the players are treated as losers.

(G) WINNER CONTINUE

Determines whether, in the Player vs. Player (from the beginning), the winner is allowed to continue game as 1P against the computer. Setting is made to ON when said continue game is allowed and to OFF when not allowed. (The standard setting is made to OFF.) Regardless of this setting, however, the BREAK INTO (Buy-in) mentioned in Item (F) above, enables the winner to continue game.

⑥ COIN ASSIGNMENTS

In this mode, the COIN/CREDIT setting, etc. can be changed.

SELECTION OF DESIRED ITEM

- 1) Press the SERVICE button to move "→" and bring it to the desired item.
- 2) Press the TEST button to change the setting.
- 3) After the desired setting is finished, bring the "→" to "EXIT" and press the TEST button.

COIN ASSIGNMENTS	
COIN CHUTE TYPE INDIVIDUAL	
CREDIT TO START 1 CREDIT	—— (A)
COIN/CREDIT SETTING # 1	—— (B)
COIN CHUTE #1 1 COIN 1 CREDIT	
MANUAL SETTING	—— (C)
→ EXIT	
SELECT BY SERVICE BUTTON AND PUSH TEST BUTTON	

COIN ASSIGNMENTS	
MANUAL SETTING	
COIN TO CREDIT 1 COIN 1 CREDIT	—— (D)
BONUS ADDER NO BONUS ADDER	—— (E)
COIN CHUTE MULTIPLIER	—— (F)
COIN 1 COIN COUNTS AS 1 COIN	
1 2 3 4 5 6 7 8 9	
1 2 3 4 5 6 7 8 9	
CREDIT	
SELECT BY SERVICE BUTTON AND PUSH TEST BUTTON	

- (A) CREDIT TO START
Sets the number of CREDITS required when starting the game (1 CREDIT, 2 CREDITS).
Even when set to 2 CREDITS, you can CONTINUE with 1 CREDIT (set to 1 CREDIT in the standard setting).
- (B) COIN/CREDIT SETTING
Sets the CREDIT increase increment per coin insertion. There are 26 settings from #1 to #26, expressed in $\bigcirc\bigcirc$ CREDIT as against $\bigcirc\bigcirc$ COINS inserted.
#26 refers to FREE PLAY (SETTING #1 in the standard setting).
Also, there are some setting numbers not shown in the INDIVIDUAL setting (for details, refer to Table 11-6-1).
- (C) MANUAL SETTING
The CREDIT's incremental increase settings as against a coin insertion are shown in further details than in (B) ... for details, refer to Table 11-6-2. Also, note that when this MANUAL SETTING is performed, the COIN/CREDIT setting becomes ineffective.
- (D) COIN TO CREDIT
Determines COIN/CREDIT setting.
For CREDIT TO START and CREDIT TO CONTINUE, refer to (A) above.
- (E) BONUS ADDER
This sets how many COINS should be inserted to obtain one SERVICE COIN.
- (F) COIN CHUTE MULTIPLIER
This sets how many tokens one COIN represents.

TABLE 11-6-1 : COIN/CREDIT SETTING
(COIN CHUTE INDIVIDUAL TYPE)

NAME OF SETTING	EACH STATION'S COIN CHUTE	
SETTING # 1	1 COIN	1 CREDIT
SETTING # 6	1 COIN	2 CREDITS
SETTING # 8	1 COIN	3 CREDITS
SETTING # 9	1 COIN	4 CREDITS
SETTING # 10	1 COIN	5 CREDITS
SETTING # 11	1 COIN	6 CREDITS
SETTING # 12	2 COINS	1 CREDIT
SETTING # 15	1 COIN 2 COINS	1 CREDIT 3 CREDITS
SETTING # 17	3 COINS	1 CREDIT
SETTING # 18	4 COINS	1 CREDIT
SETTING # 19	1 COIN 2 COINS 3 COINS 4 COINS	1 CREDIT 2 CREDITS 3 CREDITS 5 CREDITS
SETTING # 21	3 COINS 5 COINS	1 CREDIT 2 CREDITS
SETTING # 22	2 COINS 4 COINS 5 COINS	1 CREDIT 2 CREDITS 3 CREDITS
SETTING # 24	1 COIN 2 COINS 3 COINS 4 COINS 5 COINS	1 CREDIT 2 CREDITS 3 CREDITS 4 CREDITS 6 CREDITS
SETTING # 26	FREE PLAY	

TABLE 11-6-2 : MANUAL SETTING

COIN TO CREDIT	1 COIN 1 CREDIT
	2 COINS 1 CREDIT
	3 COINS 1 CREDIT
	4 COINS 1 CREDIT
	5 COINS 1 CREDIT
	6 COINS 1 CREDIT
	7 COINS 1 CREDIT
	8 COINS 1 CREDIT
	9 COINS 1 CREDIT

BONUS ADDER	NO BONUS ADDER
	2 COINS GIVE 1 EXTRA COIN
	3 COINS GIVE 1 EXTRA COIN
	4 COINS GIVE 1 EXTRA COIN
	5 COINS GIVE 1 EXTRA COIN
	6 COINS GIVE 1 EXTRA COIN
	7 COINS GIVE 1 EXTRA COIN
	8 COINS GIVE 1 EXTRA COIN
	9 COINS GIVE 1 EXTRA COIN

COIN CHUTE MULTIPLIER	1 COIN COUNTS AS 1 COIN
	1 COIN COUNTS AS 2 COINS
	1 COIN COUNTS AS 3 COINS
	1 COIN COUNTS AS 4 COINS
	1 COIN COUNTS AS 5 COINS
	1 COIN COUNTS AS 6 COINS
	1 COIN COUNTS AS 7 COINS
	1 COIN COUNTS AS 8 COINS
	1 COIN COUNTS AS 9 COINS

⑦ BOOKKEEPING

This mode allows each of the CREDIT/TIME/GAME data to be ascertained.

BOOKKEEPING, 1/2			
COIN CHUTE #1	0		
COIN CHUTE #2	0		
TOTAL COINS	0		
COIN CREDITS	0		
SERVICE CREDITS	0		
TOTAL CREDITS	0		
NUMBER OF GAMES	0		
TOTAL TIME	0D	0H	0M 0S
GAME PLAY TIME	0D	0H	0M 0S
AVERAGE GAME TIME		0H	0M 0S
LONGEST GAME TIME		0H	0M 0S
SHORTEST GAME TIME		0H	0M 0S
PUSH TEST BUTTON TO CONTINUE			

- (A) COIN CHUTE #1
Displays the COIN IN frequency of the COIN CHUTE for the left side player.
- (B) COIN CHUTE #2
Displays the COIN IN frequency of the COIN CHUTE for the right side player.
- (C) TOTAL COINS
Total operation count of coin chutes.
(A)+(B)
- (D) COIN CREDITS
Number of CREDITS registered by COIN insertion only.
- (E) SERVICE CREDITS
The SERVICE SWITCH usage frequency.
- (F) TOTAL CREDITS
Total number of CREDITS.
(D)+(E)
- (G) NUMBER OF GAMES
Total games played.

- (H) TOTAL TIME
Total time the machine is energized.
- (I) GAME PLAY TIME
Total game playtime.
- (J) AVERAGE GAME TIME
Average game playtime.
- (K) LONGEST GAME TIME
Longest game playtime.
- (L) SHORTEST GAME TIME
Shortest game playtime.

BOOKKEEPING 2/2		
TIME HISTOGRAM		
0' 00"	~ 0' 59"	0
1' 00"	~ 1' 29"	0
1' 30"	~ 1' 59"	0
2' 00"	~ 2' 29"	0
2' 30"	~ 2' 59"	0
3' 00"	~ 3' 29"	0
3' 30"	~ 3' 59"	0
4' 00"	~ 4' 29"	0
4' 30"	~ 4' 59"	0
5' 00"	~ 5' 59"	0
6' 00"	~ 6' 59"	0
7' 00"	~ 7' 59"	0
8' 00"	~ 8' 59"	0
9' 00"	~ 9' 59"	0
OVER	10' 00"	0
PUSH TEST BUTTON TO EXIT		

This screen displays the breakdown bookkeeping of the play time per play in the form of histogram. When setting the GAME DIFFICULTY, etc., refer to this as a standard.

Pressing the TEST button causes the MENU to return on to the screen.

⑧ BACKUP DATA CLEAR

Clears the contents of BOOKKEEPING.

BACKUP DATA CLEAR

YES (CLEAR)

→ NO (CANCEL)

SELECT BY SERVICE BUTTON
PUSH TEST BUTTON

When clearing, bring "→" to "YES" and when not clearing, to "NO", by using the SERVICE SW, and then push the TEST button.

Bring "→" to "NO" and press the TEST button to cause the MENU mode to return on to the screen.

When the data has been cleared, "COMPLETED" will be displayed and the MENU mode returns on to the screen.

⑨ OUTPUT TEST

In this mode, the lighting test of CORNER and START lamps can be performed.

Selection of TEST ITEM

- 1) Press the SERVICE button to move the "→" and bring it to the desired item.
- 2) Press the TEST button to change the setting.
- 3) After the desired setting is finished, bring the "→" to "EXIT" and press the TEST button.

OUTPUT TEST		
BLUE CORNER LAMP	OFF	—— (A)
RED CORNER LAMP	OFF	—— (B)
BLUE BUTTON 1P LAMP	OFF	—— (C)
BLUE BUTTON 2P LAMP	OFF	—— (D)
RED BUTTON 1P LAMP	OFF	—— (E)
RED BUTTON 2P LAMP	OFF	—— (F)
→ EXIT		
SELECT BY SERVICE BUTTON AND PUSH TEST BUTTON		

- (A) BLUE CORNER LAMP The BILLBOARD's left-hand side lamp
- (B) RED CORNER LAMP The BILLBOARD's right-hand side lamp
- (C) BLUE BUTTON 1P LAMP The left-hand side 1P START button
- (D) BLUE BUTTON 2P LAMP The left-hand side 2P START button
- (E) RED BUTTON 1P LAMP The right-hand side 1P START button
- (F) RED BUTTON 2P LAMP The right-hand side 2P START button

12. GAME BOARD

12-1 COMPOSITION OF GAME BOARD

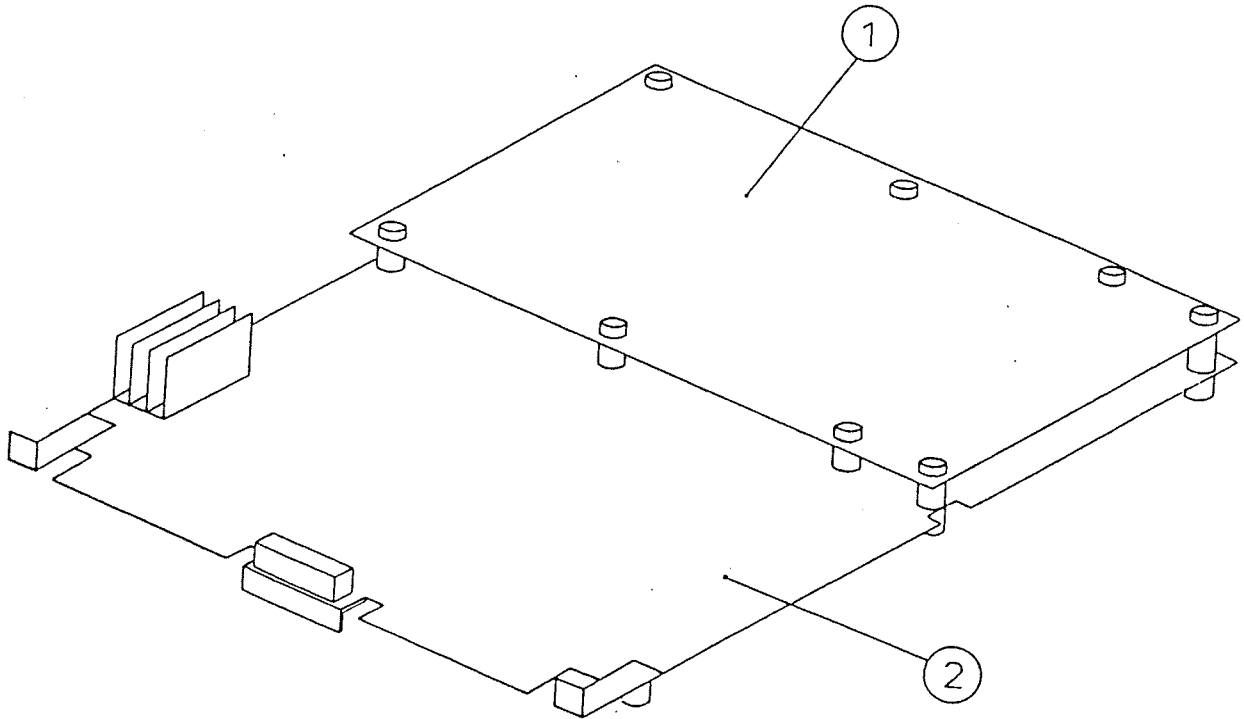

	U. S. A.	OTHERS
GAME BOARD NO.	8 3 4 - 9 3 2 4 - 0 1	8 3 4 - 9 3 2 4 - 0 2
① ROM BD NO.	8 3 4 - 9 4 1 3 - 0 1	8 3 4 - 9 4 1 3 - 0 2
② MAIN BD NO.	8 3 7 - 8 6 7 6 (SYSTEM MULTI 32)	

When the SERVICE DOOR on the lower left side of the cabinet's front part is opened, the SHIELD CASE appears. The GAME BD is contained in the SHIELD CASE.

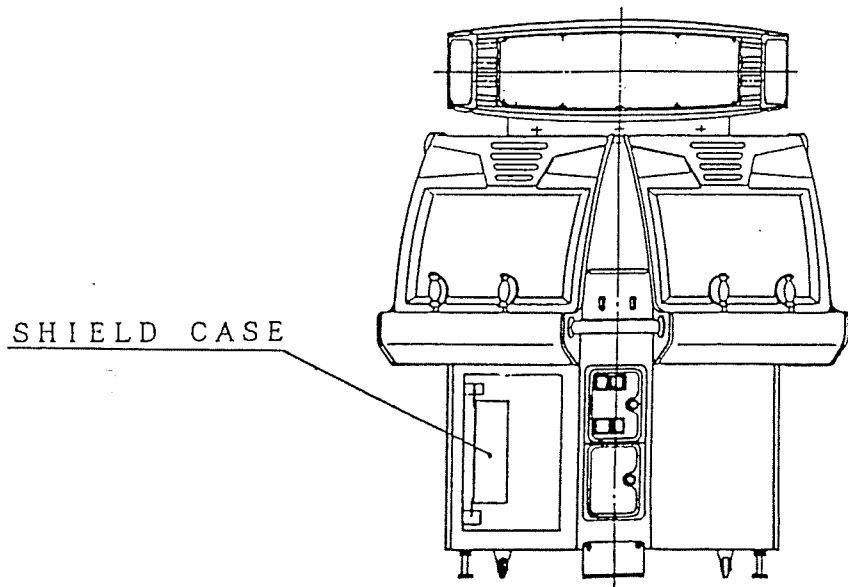

12-2 ROM LOCATION

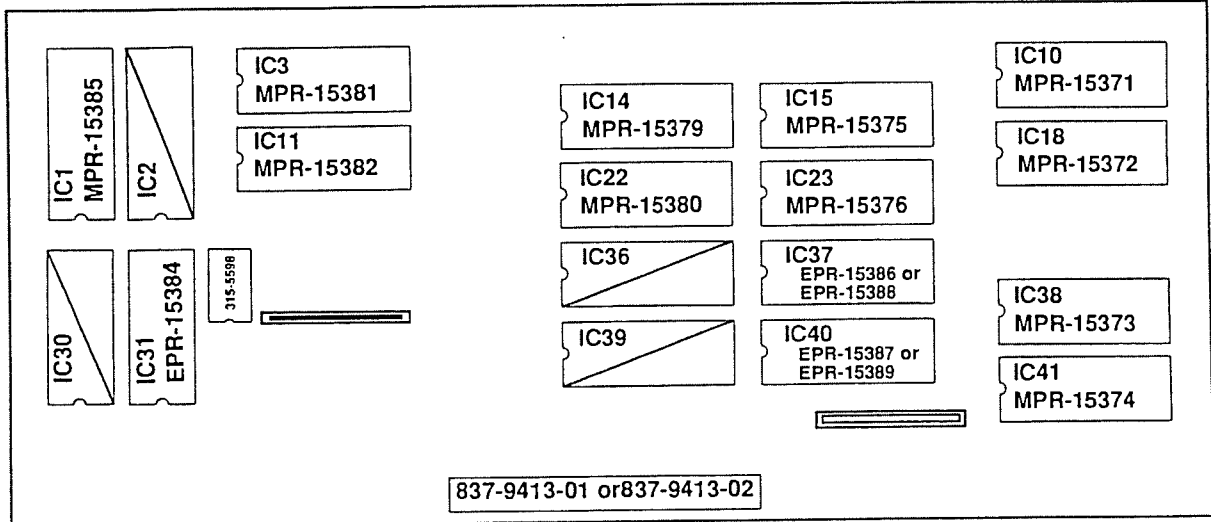

I C LOCATION		ROM NUMBER			MAIN WORK
		USA	OTHERS		
1	IC 37	EPR-15386	EPR-15388	2 M	PROGRAM
2	IC 40	EPR-15387	EPR-15389	2 M	
3	IC 10	MPR-15371		1 6 M	OBJECT
4	IC 18	MPR-15372		1 6 M	
5	IC 38	MPR-15373		1 6 M	
6	IC 41	MPR-15374		1 6 M	
7	IC 15	MPR-15375		1 6 M	
8	IC 23	MPR-15376		1 6 M	
9	IC 14	MPR-15379		1 6 M	
10	IC 22	MPR-15380		1 6 M	SCROLL
11	IC 3	MPR-15381		1 6 M	
12	IC 11	MPR-15382		1 6 M	SOUND
13	IC 1	MPR-15385		1 6 M	
14	IC 31	MPR-15384		1 M	

13. DESIGN RELATED PARTS

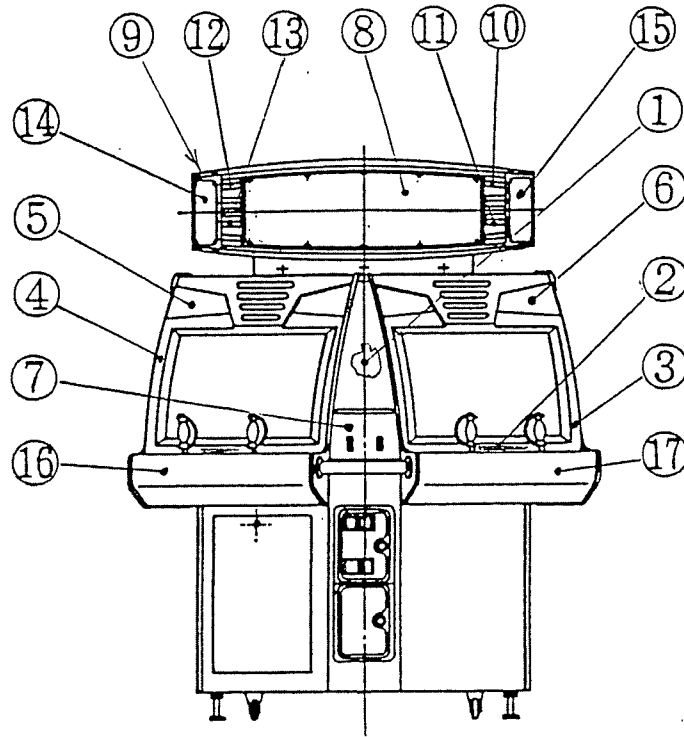

- | | | | |
|----|-------------|-------|-------------------------------|
| 1 | 422-0443-01 | | PLAY INSTR SH TITLE FIGHT ENG |
| 2 | 422-0442-01 | | SUB INSTR HWC ENG |
| 3 | HWC-1010 | | ASSY FRONT MASK RED |
| 4 | HWC-1011 | | ASSY FRONT MASK BLUE |
| 5 | HWC-1010-B | | STICKER A |
| 6 | HWC-1010-C | | STICKER B |
| 7 | HWC-1015 | | ENTRY PLATE |
| 8 | 423-0187 | | BILLBOARD PLATE HWC |
| 9 | HWC-1104X | | BILLBOARD |
| 10 | HWC-1104-B | | HWC BILLBOARD STICKER R. A |
| 11 | HWC-1104-C | | HWC BILLBOARD STICKER R. B |
| 12 | HWC-1104-D | | HWC BILLBOARD STICKER L. A |
| 13 | HWC-1104-E | | HWC BILLBOARD STICKER L. B |
| 14 | HWC-1107X | | LAMP COVER BLUE |
| 15 | HWC-1108X | | LAMP COVER RED |
| 16 | HWC-2001X | | CONTROL PANEL LEFT |
| 17 | HWC-2101X | | CONTROL PANEL RIGHT |

14. PARTS LIST





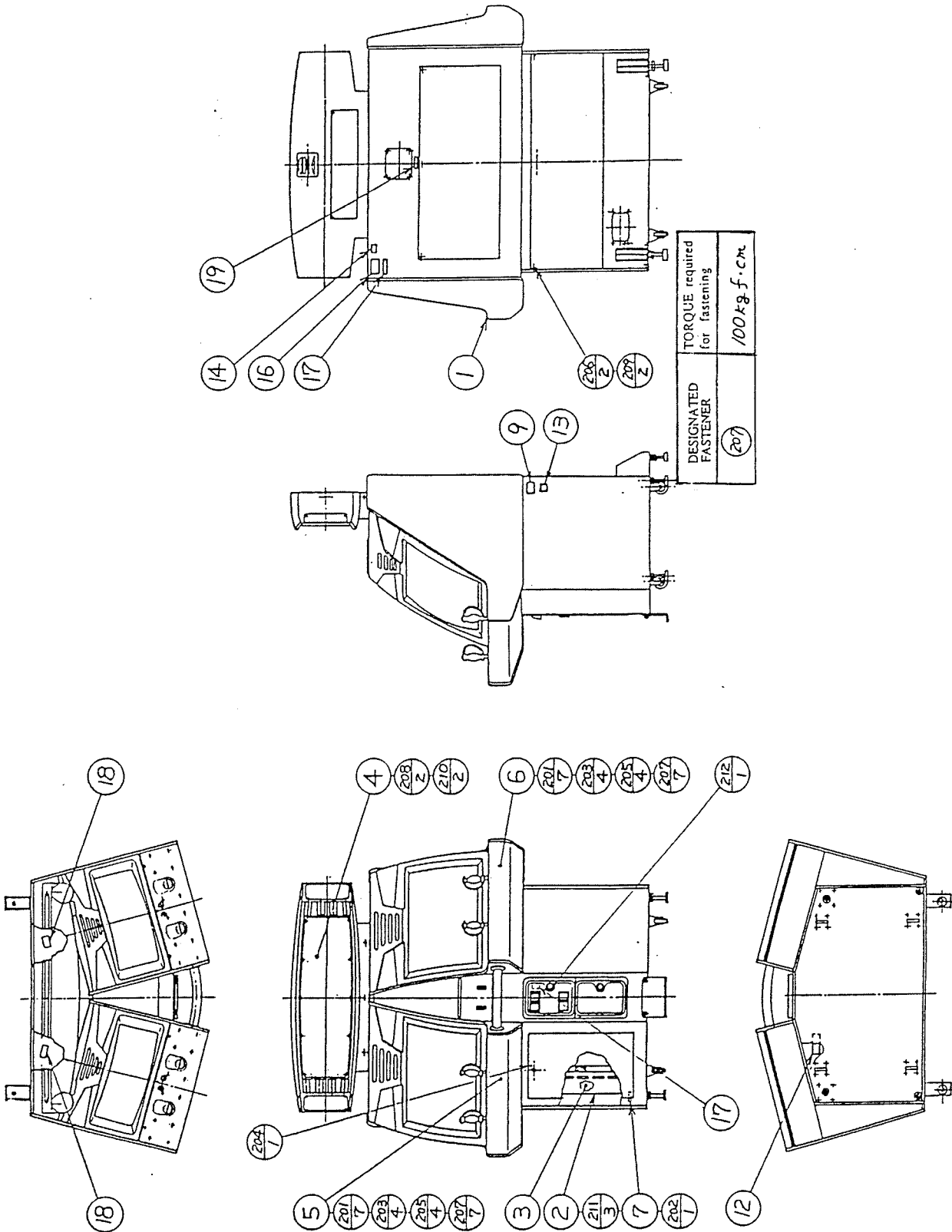







① TOP ASSY TITLE FIGHT

(D-1/4)



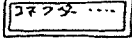















① TOP ASSY TITLE FIGHT

(D-2/4)

ITEM NO.	PART NO.	DESCRIPTION		NOTE
1	HWC-0100	ASSY CABI HWC		
2	HWC-0500	ASSY SHIELD CASE		
3	834-9324-02	GAME BD TITLE FIGHT	OTHERS	
	834-9324-01	GAME BD TITLE FIGHT	USA	
4	HWC-0200	ASSY BILLBOARD HWC		
5	HWC-2000	ASSY CONT PNL LEFT		
6	HWC-2100	ASSY CONT PNL RIGHT		
7	HWC-0003	SHIELD CASE STOPPER		
8	SGM-4048	POLYETHYLENE COVER 1250×1800×2100		
11	421-6594	STICKER SERIAL NO INFO		
12	421-6709	STICKER SERVICE INSTR ENG		
15	SGM-4111	KEY BAG		
16	421-7987	STICKER ELEC SPEC		
17	421-7988	STICKER SERIAL NUMBER		
18	421-6671	STICKER DANGER HIGH VOLTAGE		
201	069-0087	FLT WSHR CROME M8		
202	000-0416-FS	M SCR PH W/FS M4×16		
203	051-0005	FLG NUT M5		
204	029-0001	M SCR TH CRM M4×25		
205	029-0328	M SCR TH CRM M5×25		
206	029-0400	M SCR PH CRM M5×40		
207	029-0444	TMP PRF SCR BH CRM M8×20		
208	039-0098	HEX BLT BLK W/S M8×35		
209	069-0135	FLT WSHR CRM 5.5-20×1.6		
210	069-0058	FLT WSHR 8.5-22×1.6		





① TOP ASSY TITLE FIGHT

(D-3/4)

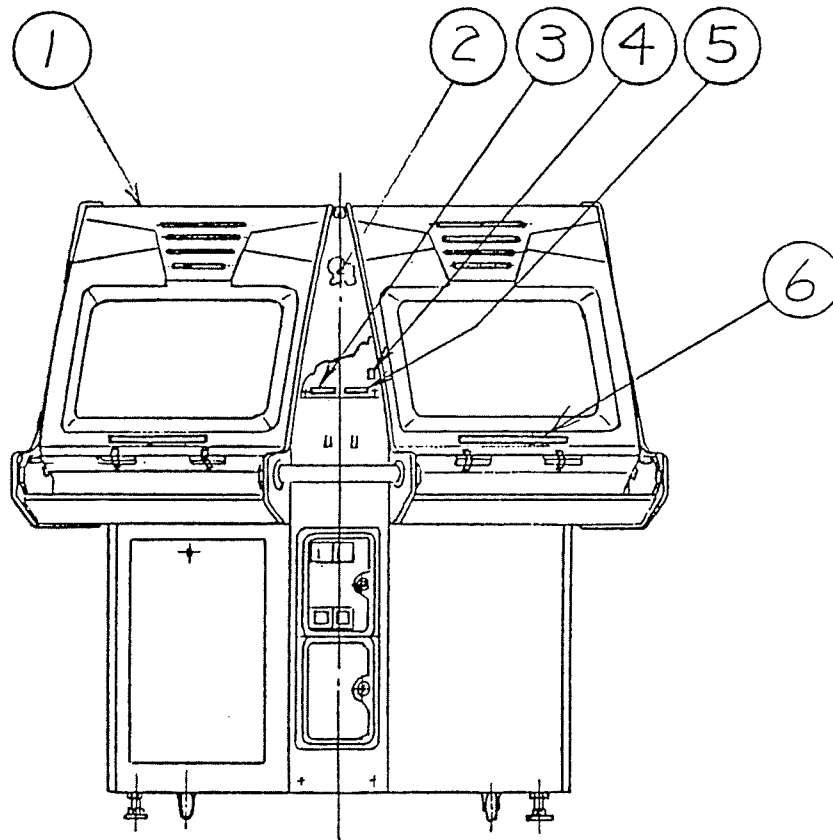
ITEM NO.	PART NO.	DESCRIPTION	NOTE
211	000-0308-FS	M SCR PH W/FS M3×8	
212	029-0385	M SCR TH BLK M4×30	
402	SGM-2675	POLYETHYLENE BAG 240×370	
403	540-0006-01	WRENCH FOR TAMP PRF SCR DUAL TYPE M4	
404	540-0007-01	WRENCH FOR TAMP PRF SCR DUAL TYPE M5	
405	540-0009-01	WRENCH FOR TAMP PRF SCR DUAL TYPE M8	
406	420-5962	DSPL MANUAL 26" 200-5187 ENG	
	420-5963	DSPL MANUAL 26" 200-5195 ENG	
407	420-6071-01	OWNERS MANUAL TITLE FIGHT ENG	
409	514-5036-5000	FUSE 6.4φ×30 5000mA 125V	
410	509-5218	PUSH BUTTON SW IT YELLOW W/LAMP	
411	509-5466	SW MICRO TYPE (AM50033C5)	
412	HWC-0001	SUB LEG BRACKET	
413	601-5882	LEG ADJUSTER φ60	
414	059-0065	HEX NUT (3種) M16	
415	039-0157	HEX BLT CRM W/FS M8×35	
416	029-0445	W SCR RH W/F CRM 3.5×16	
417	HWC-2215	RUBBER	
419	HWC-0004	STOPPER BRACKET	
420	069-0123	FLT WSHR CRM 8.5-22×1.6	
421	HWC-2014	CAP COVER RED	
422	HWC-2015	CAP COVER BLUE	
423	601-6604-70	CARTON BOX 70	
	029-0444	TMP PRF SCR BH CRM M8×20	
	421-6690~	STICKER ~V	



② ASSY CABI HWC (HWC-0100)

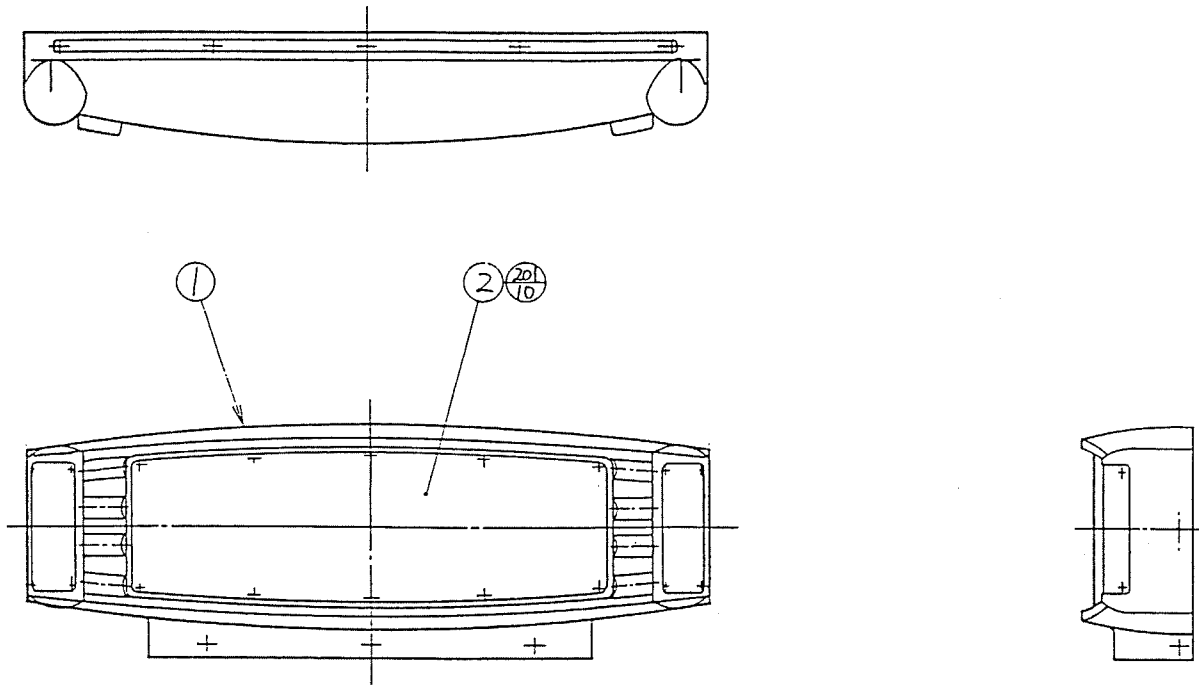

ITEM NO.	PART NO.	DESCRIPTION	NOTE
1	HWC-1000	ASSY CABI COM	
2	422-0443-01	PLAY INSTR SH TITLE FIGHT ENG	
4	421-5800-198	ORIGINAL SEAL TITLE FIGHT	
6	422-0442-01	SUB INSTR HWC ENG	

③ ASSY BILLBOARD HWC (HWC-0200)



ITEM NO.	PART NO.	DESCRIPTION	NOTE
1	HWC-1100	ASSY BILLBOARD COM	
2	423-0187	BILLBOARD PLATE HWC	
201	029-0014	M SCR TH CRM M4×12	





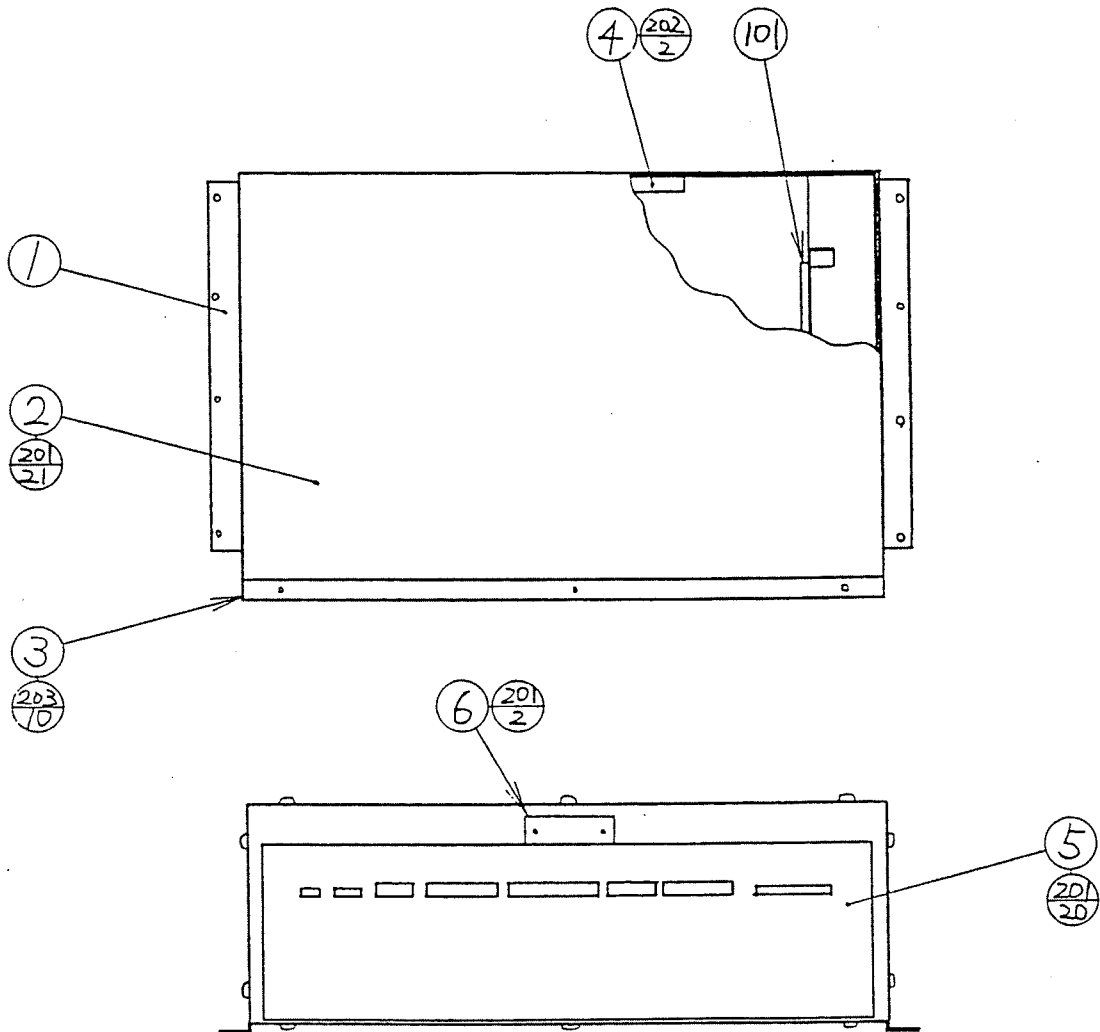

④ ASSY SHIELD CASE (HWC-0500)

(D-1/2)

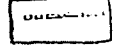

④ ASSY SHIELD CASE (HWC-0500)

(D-2/2)

ITEM NO.	PART NO.	DESCRIPTION	NOTE
1	SCR-0501-01	SHIELD CASE	
2	SCR-0502-01	UPPER COVER	
3	SCR-0507-01	SHIELD COVER	
4	SCR-0504	HOLDER	
5	839-0538	SYSTEM MULTI FLT BD	
6	SCR-0508	COVER	
101	280-5232	GUIDE RAIL	
201	010-0308	S-TITE SCR PH W/F M3×8	
202	012-0308	TAP SCR PH 3×8	
203	000-0410-FS	M SCR PH W/FS M4×10	





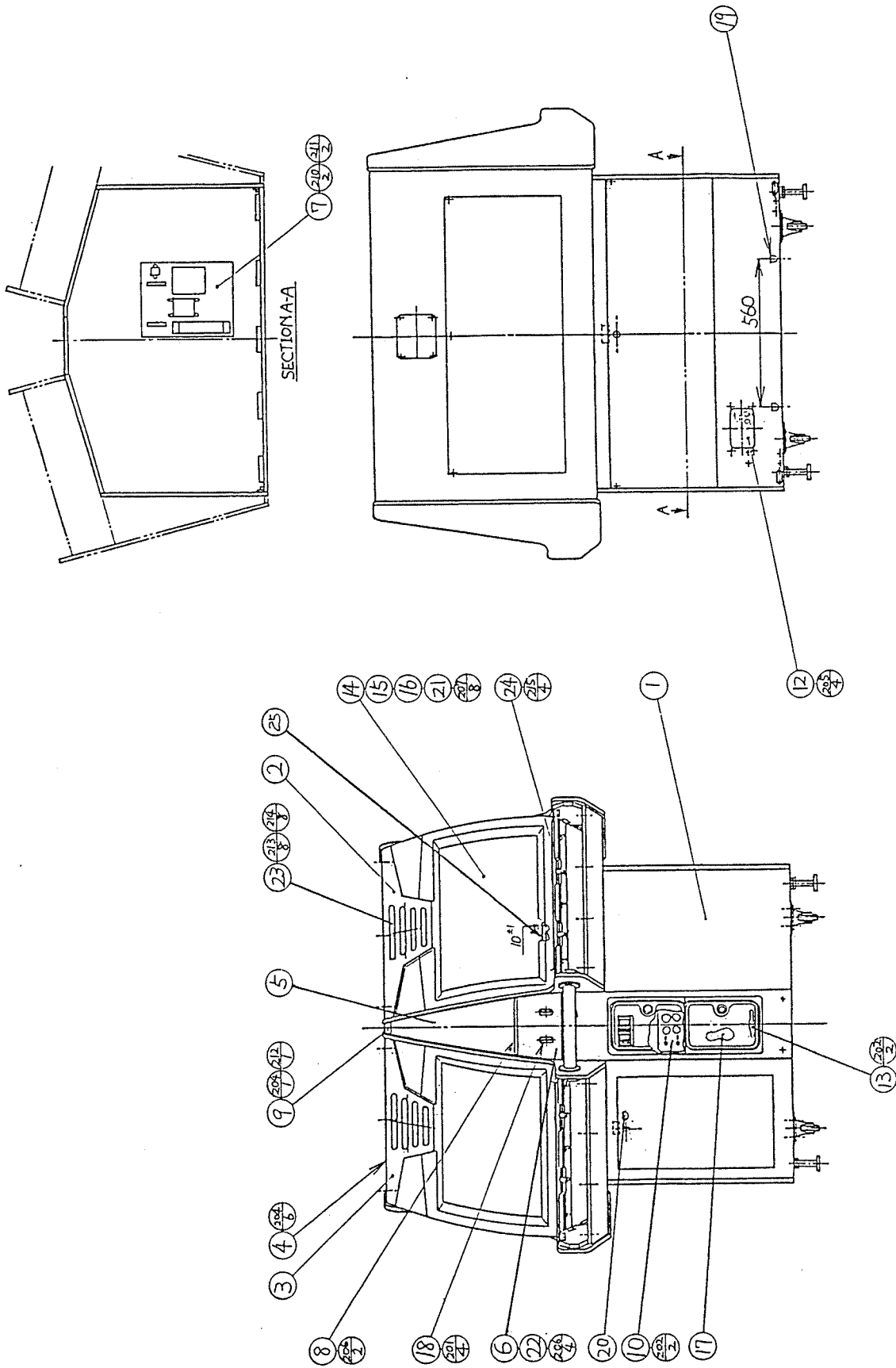



















⑤ ASSY CABI COM (HWC-1000)

(D-1/3)





⑤ ASSY CABI COM (HWC-1000)

(D-2/3)

ITEM NO.	PART NO.	DESCRIPTION	NOTE
1	HWC-1001	ASSY SUBCABI	
2	HWC-1010	ASSY FRONT MASK RED	
3	HWC-1011	ASSY FRONT MASK BLUE	
4	HWC-1013	FRONT MASK HOLDER	
5	HWC-1014	PLASTIC PLATE	
6	HWC-1015	ENTRY PLATE	
7	HWC-4000	ASSY POWER SPPLY	
8	HWC-1018	HOLDER LOWER	
9	HWC-1019	HOLDER UPPER	
10	HWC-1020	SW UNIT	
12	HWC-1026	AC UNIT	
13	HWC-1028	METER UNIT	
14	280-5112	BUSH FOR TV	
15	280-5113	COLLAR FOR TV	
16	280-5114	SPACER 6.4-25×2	
17	253-5366	CASH BOX	
18	220-5167~	COIN ENTRY~	
19	421-7020	STICKER CAUTION FORK	
21	200-5187-15	ASSY CLR DSPL 26 TYPE 15K 100V	
	200-5195-15	ASSY CLR DSPL 26 TYPE 15K 100V	
22	421-7907~	DENOMI SH BLUE PLAYER ~	
23	HWC-1012	SPEAKER COVER	
24	HWC-1017	STOPPER	
25	HWC-1036	CUSHION	
101	280-5225	CORD CLAMP 21	

⑤ ASSY CABI COM (HWC-1000)

(D-3/3)

ITEM NO.	PART NO.	DESCRIPTION	NOTE
102	601-0460	PLASTIC TIE BELT 100mm	
103	280-0419	HARNESS LUG	
104	280-5126	CORD CLAMP ϕ 25	
201	000-0308-S	M SCR PH W/S M3 \times 8	
202	000-0408-FS	M SCR PH W/FS M4 \times 8	
204	029-0169	TMP PRF SCR TH CHROME M4 \times 16	
205	029-0192	TMP PRF SCR TH CROME M5 \times 20	
206	029-0337	TMP PRF SCR TH CRM M4 \times 20	
207	051-0006	FLG NUT M6	
208	006-3110	W SCR FH 3.1 \times 10	
209	005-3110	W SCR RH 3.1 \times 10	
210	000-0535-FS	M SCR PH W/FS M5 \times 35	
211	069-0001	FLT WSHR 5.5-20 \times 1.6	
212	029-0048	M SCR TH UNICROM M3 \times 5	
213	039-0131	CRG BLT CRM M4 \times 14	
214	051-0004	FLG NUT M4	
215	032-0406	WNG BLT M4 \times 6	
216	090-0075	STATIC SHEET (20 \times 35)	
301	600-6215-19	WIRE HARN ASSY DC	
302	600-6215-26	WIRE HARN ASSY AC	
303	600-6215-32	WIRE HARN EXT DEMAG SW	

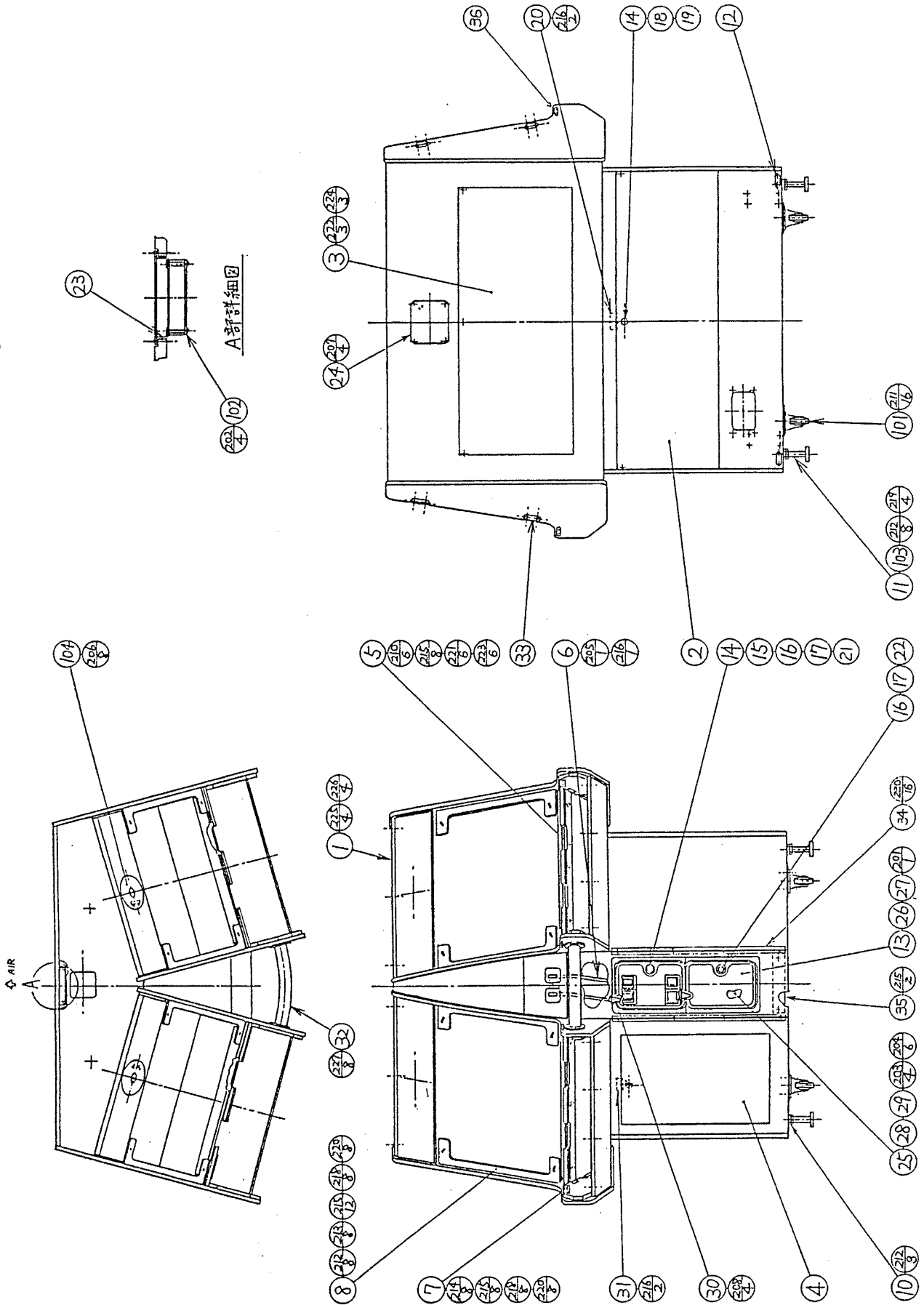

⑥ ASSY SUBCABI (HWC-1001)

(D-1/5)















⑥ ASSY SUBCABI (HWC-1001)

(D-2/5)

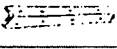
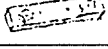
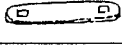
ITEM NO.	PART NO.	DESCRIPTION	NOTE
1	HWC-1002	WOODEN CABINET	
2	HWC-1003	BACK DOOR	
3	HWC-1004	UPPER DOOR	
4	HWC-1005	FRONT DOOR	
5	HWC-1006	STOPPER CONT PNL	
6	HWC-1007	COIN CHUTE UPPER	
7	HWC-1008X	HOLDER A	
8	HWC-1009	MONITOR BRKT	
10	PSR-1004	LEG BRACKET	
11	ARC-1006	LEG BRACKET	
12	117-5216	PLATE LEG BRACKET	
13	220-5166~	ASSY COIN CHUTE SPCL 2DOOR~	
14	220-5380	MAG LOCK MASTER W/O KEY	
15	220-5381	KEY MASTER FOR 220-5380	
16	HN-1050	SPACER RING	
17	DP-1167	TNG LKG	
18	DP-1148X	LKG TNG	
19	117-0062	PLATE LOCK RETAINER	
20	117-5098	TNG RETAINER PLATE	
21	105-5068	PLATE TONGUE STOPPER	
22	220-5046-91	MAGNETIC LOCK W/KEYS	
23	HN-1042X	FAN BRKT	
24	117-5151	GUARD PLATE 140×160	
25	KR-1608	LOCK BRACKET	
26	109-0045-91	KEY HOLDER	
27	421-7501-02	STICKER 6.3V 0.15A	

⑥ ASSY SUBCABI (HWC-1001)

(D-3/5)

ITEM NO.	PART NO.	DESCRIPTION	NOTE
28	105-5106	CASH BOX COVER	
29	105-5107	CHUTE	
30	MX-1009	COIN CHUTE MIDDLE	
31	117-0063	PLATE TONGUE RETAINER	
32	HWC-1030	DESIGN PIPE	
33	117-5234	PLATE 6-40	
34	HWC-1034	ORNAMENT	
35	HWC-1035	NUT PLATE	
36	HWC-1037	PLATE 6-120	
101	601-6224	CASTER $\phi 75$	
102	260-0011-02	AXIAL FLOW FAN AC100V 50-60Hz	
103	601-5882	LEG ADJUSTER $\phi 60$	
104	130-5087	SPEAKER W/SHLD 4 OHM $\phi 160$	
105	280-5225	CORD CLAMP 21	
106	280-0419	HARNESS LUG	
107	280-0425	CORD CLAMP $\phi 10$	
108	310-5029-D20	SUMITUBE F D20MM	
109	601-0460	PLASTIC TIE BELT 100MM	
201	000-0308-FS	M SCR PH W/FS M3 \times 8	
202	000-0345-FS	M SCR PH W/FS M3 \times 45	
203	000-0406-S	M SCR PH W/S M4 \times 6	
204	000-0408-FS	M SCR PH W/FS M4 \times 8	
205	000-0416-FS	M SCR PH W/FS M4 \times 16	
206	000-0430-FS	M SCR PH W/FS M4 \times 30	





⑥ ASSY SUBCABI (HWC-1001)

(D-4/5)

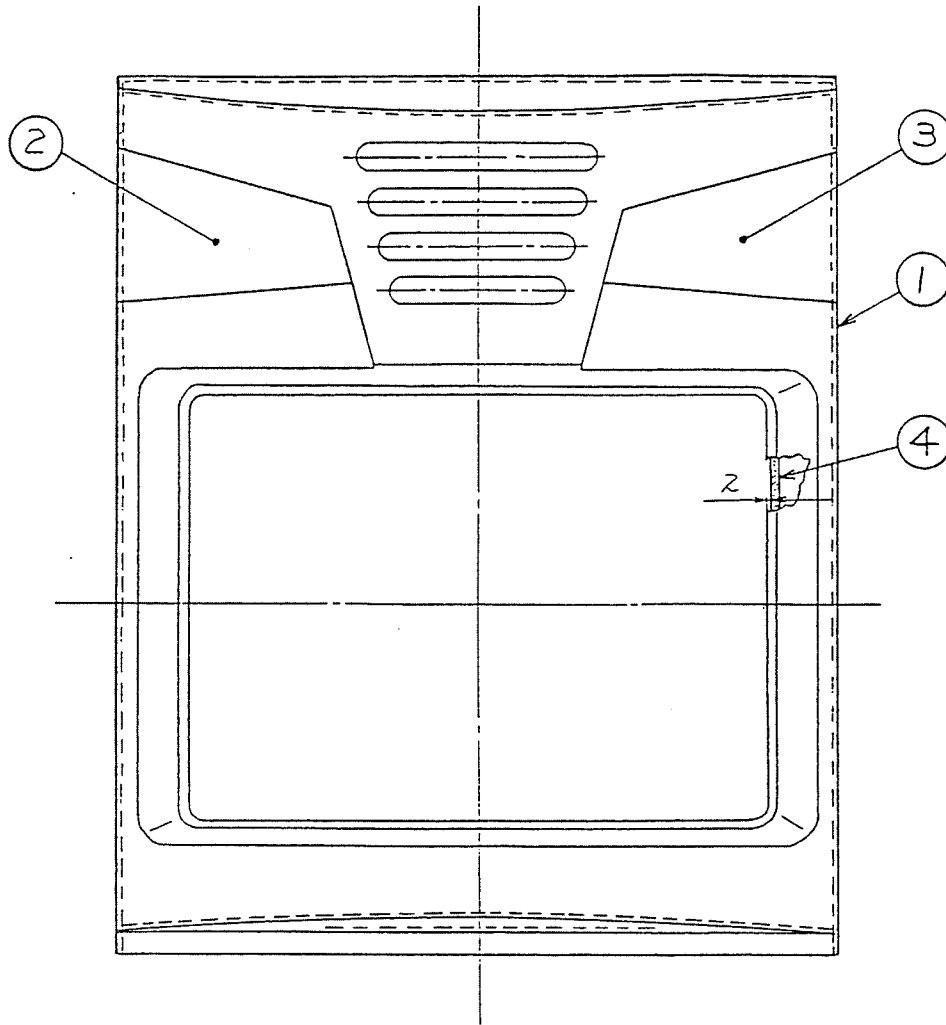
ITEM NO.	PART NO.	DESCRIPTION	NOTE
207	029-0150	M SCR TH BLK M4×25	
208	010-0306-F	S-TITE SCR PH W/F M3×6	
210	030-0845	HEX BLT M8×45	
211	039-0152	HEX BLT BLK W/FS M6×30	
212	039-0150	HEX BLT W/FS M6×25	
213	039-0087	CRG BLT CRM M6×30	
214	039-0064	CRG BLT CRM M6×50	
215	005-3516-F	W SCR RH W/F 3.5×16	
216	005-3113-F	W SCR RH W/F 3.1×13	
218	050-0006	HEX NUT M6	
219	059-0065	HEX NUT (3種) M16	
220	061-0006	SPR WSHR M6	
221	061-0008	SPR WSHR M8	
222	069-0135	FLT WSHR CRM 5.5-20×1.6	
223	069-0058	FLT WSHR 8.5-22×1.6	
224	029-0382	TMP PRF SCR TH CRM M5×35	
225	051-0005	FLG NUT M5	
226	031-0530	CRG BLT M5×30	
227	029-0413	M SCR TH CRM M5×40	
228	005-3110	W SCR RH 3.1×10	
229	006-3110	W SCR FH 3.1×10	
230	046-0001	SCR NAIL TH STAINLESS	
301	600-6215-39	WIRE HARN COIN SW LEFT	
302	600-6215-40	WIRE HARN COIN SW RIGHT	
303	600-6215-43	WIRE HARN SP LEFT	





⑦ ASSY FRONT MASK RED (HWC-1010)

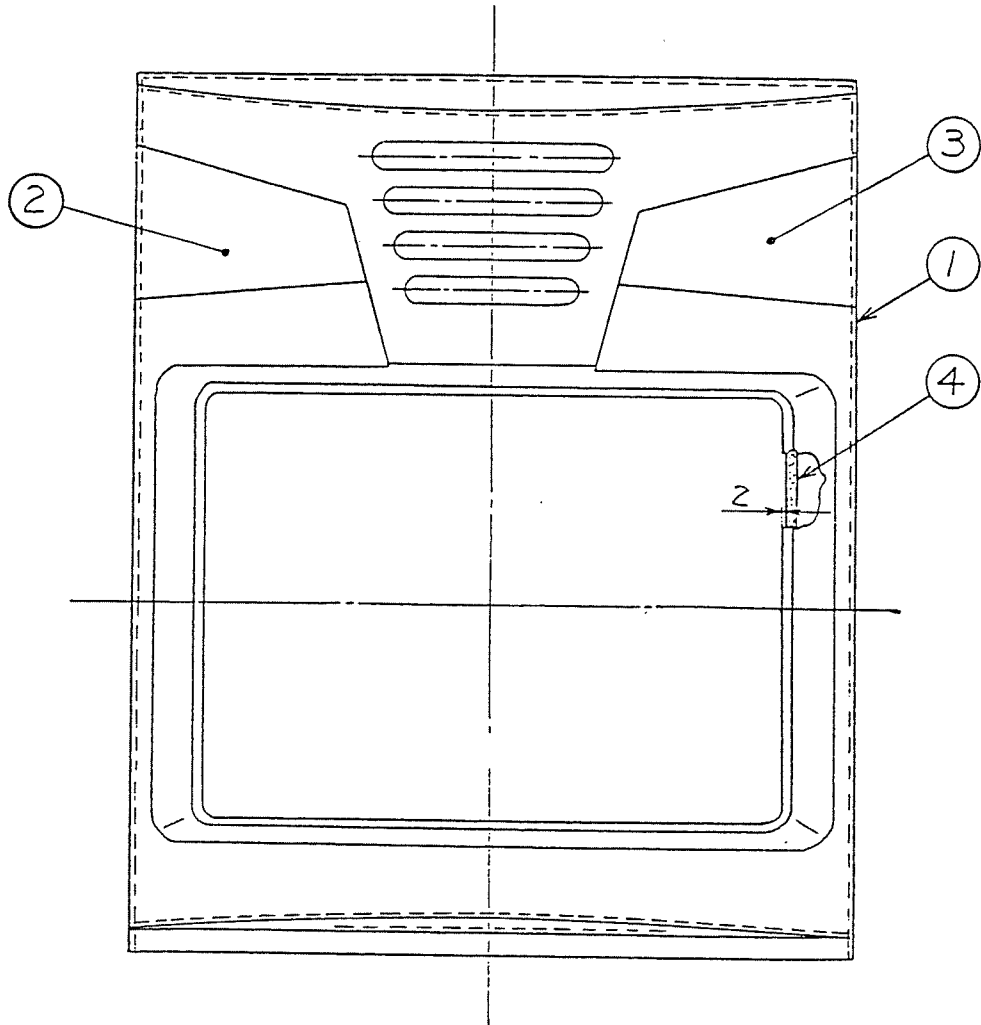

ITEM NO.	PART NO.	DESCRIPTION	NOTE
1	HWC-1010-A	FRONT MASK RED	
2	HWC-1010-B	STICKER A	
3	HWC-1010-C	STICKER B	
4	HWC-1010-D	RUBBER CUSHION	

⑧ ASSY FRONT MASK BLUE (HWC-1011)



ITEM NO.	PART NO.	DESCRIPTION	NOTE
1	HWC-1011-A	FRONT MASK BLUE	
2	HWC-1010-B	STICKER A	
3	HWC-1010-C	STICKER B	
4	HWC-1010-D	RUBBER CUSHION	

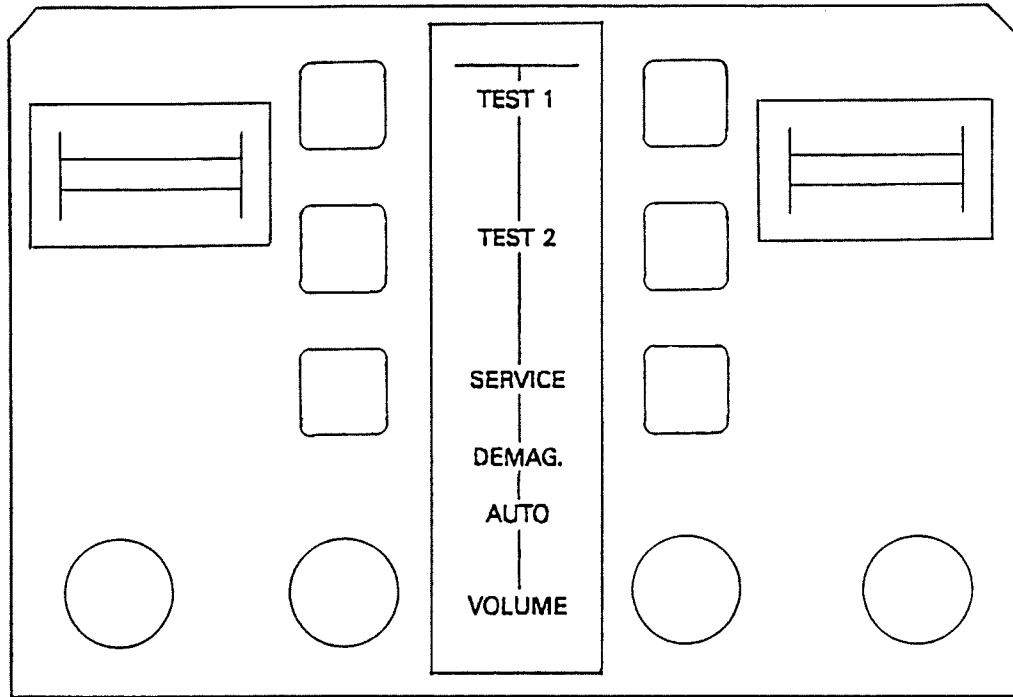





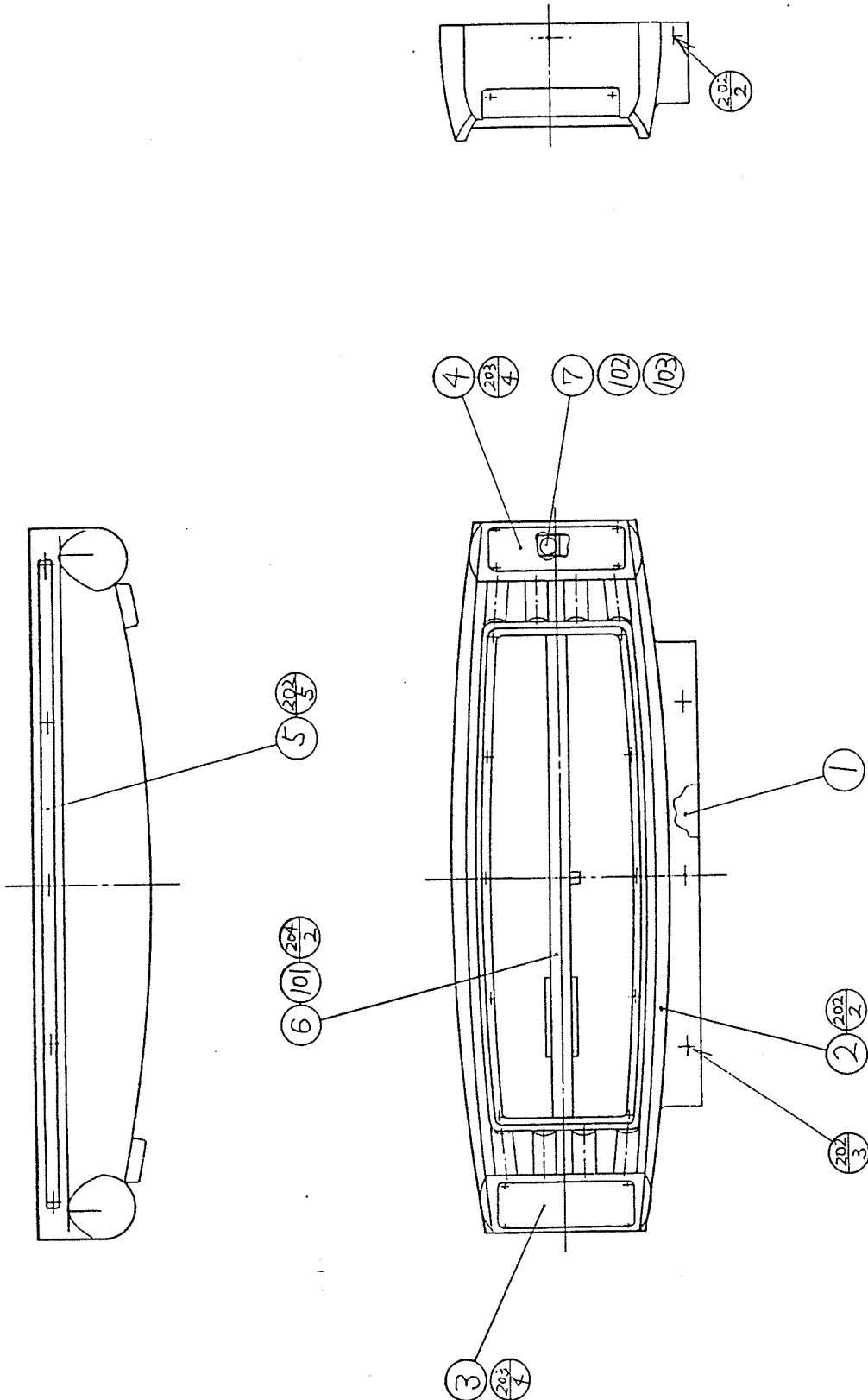







⑫ ASSY BILLBOARD COM (HWC-1100)

(D-1/2)



⑫ ASSY BILLBOARD COM (HWC-1100)

(D-2/2)

ITEM NO.	PART NO.	DESCRIPTION	NOTE
1	HWC-1101	ASSY SUBCABI BILLBOARD	
2	HWC-1104X	BILLBOARD	
3	HWC-1107X	LAMP COVER BLUE	
4	HWC-1108X	LAMP COVER RED	
5	HWC-1106	SASH	
6	421-7501-18	STICKER FL 32W	
7	421-7501-08	STICKER 110V 15W	
101	390-5276-32-01	ASSY FL UNIT 32W EX	
102	390-5257	LAMP 110V 15W	
103	214-0118	LAMP SOCKET	
104	280-0419	HARNESS LUG	
105	209-0023	CONN CLOSED END	
106	601-0460	PLASTIC TIE BELT 100mm	
202	029-0001	M SCR TH CRM M4×25	
203	029-0014	M SCR TH CRM M4×12	
204	000-0425-FS	M SCR PH W/FS M4×25	
205	005-3110	W SCR RH 3.1×10	
301	600-6215-50	WIRE HARN FL	
302	600-6215-51	WIRE HARN WINNER LAMP	

⑬ ASSY SUBCABI BILLBOARD (HWC-1101)

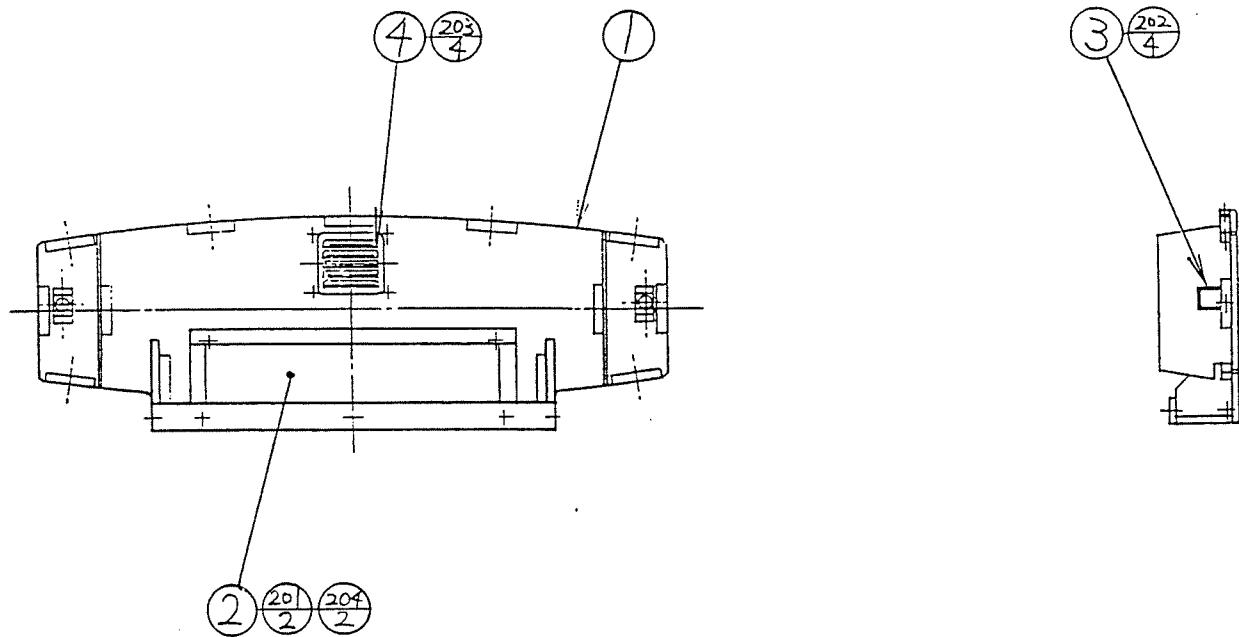
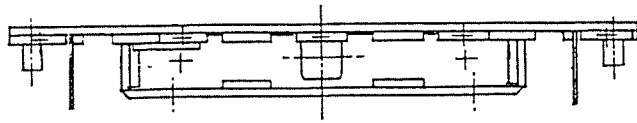

ITEM NO.	PART NO.	DESCRIPTION	NOTE
1	HWC-1102	BILLBOARD CABI	
2	HWC-1103	BILLBOARD DOOR REAR	
3	HWC-1109	LAMP BRACKET	
4	PSR-1114	AIR VENT	
201	029-0001	M SCR TH CRM M4×25	
202	005-3113-F	W SCR RH W/F 3.1×13	
203	029-0329	M SCR TH CRM M4×16	
204	069-0110	FLT WSHR CRM 4.4-16×1.6	

⑭ BILLBOARD (HWC-1104X)

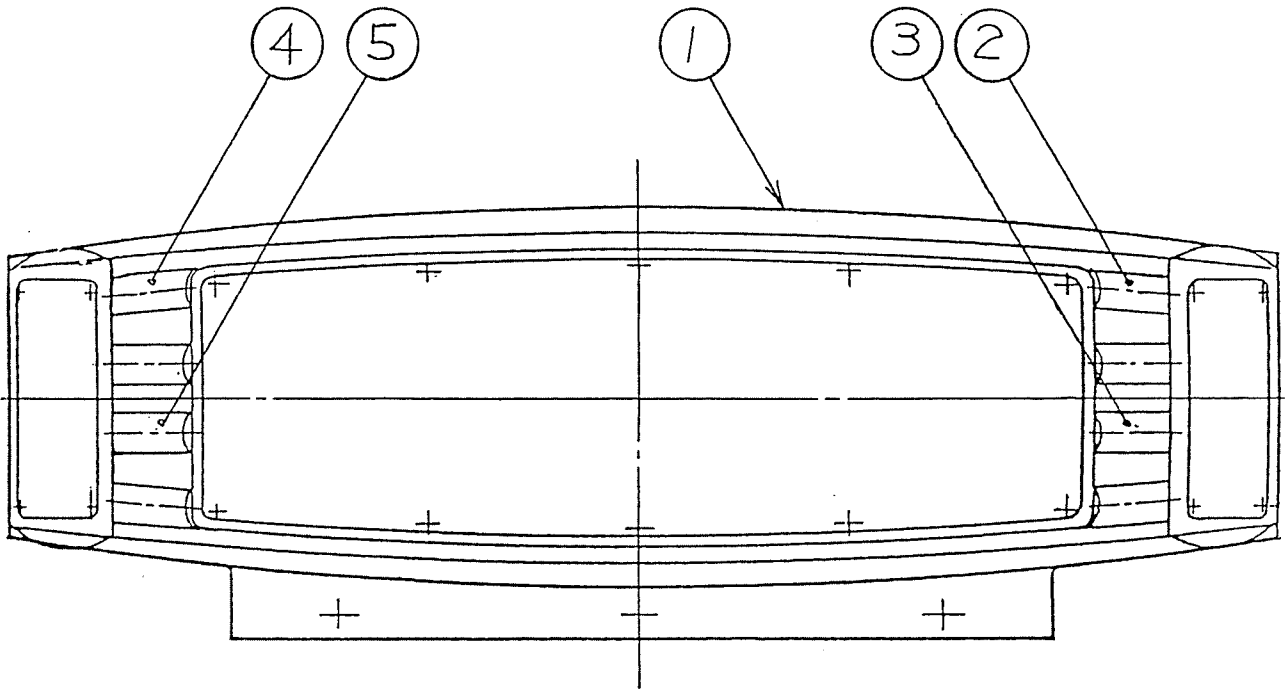

ITEM NO.	PART NO.	DESCRIPTION	NOTE
1	HWC-1104X-A	BILLBOARD BLANK	
2	HWC-1104-B	HWC BILLBOARD STICKER R. A	
3	HWC-1104-C	HWC BILLBOARD STICKER R. B	
4	HWC-1104-D	HWC BILLBOARD STICKER L. A	
5	HWC-1104-E	HWC BILLBOARD STICKER L. B	

⑮ ASSY CONT PNL LEFT (HWC-2000)

(D-1/2)

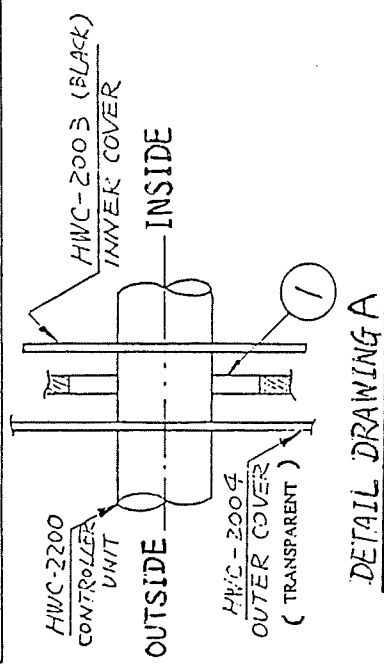
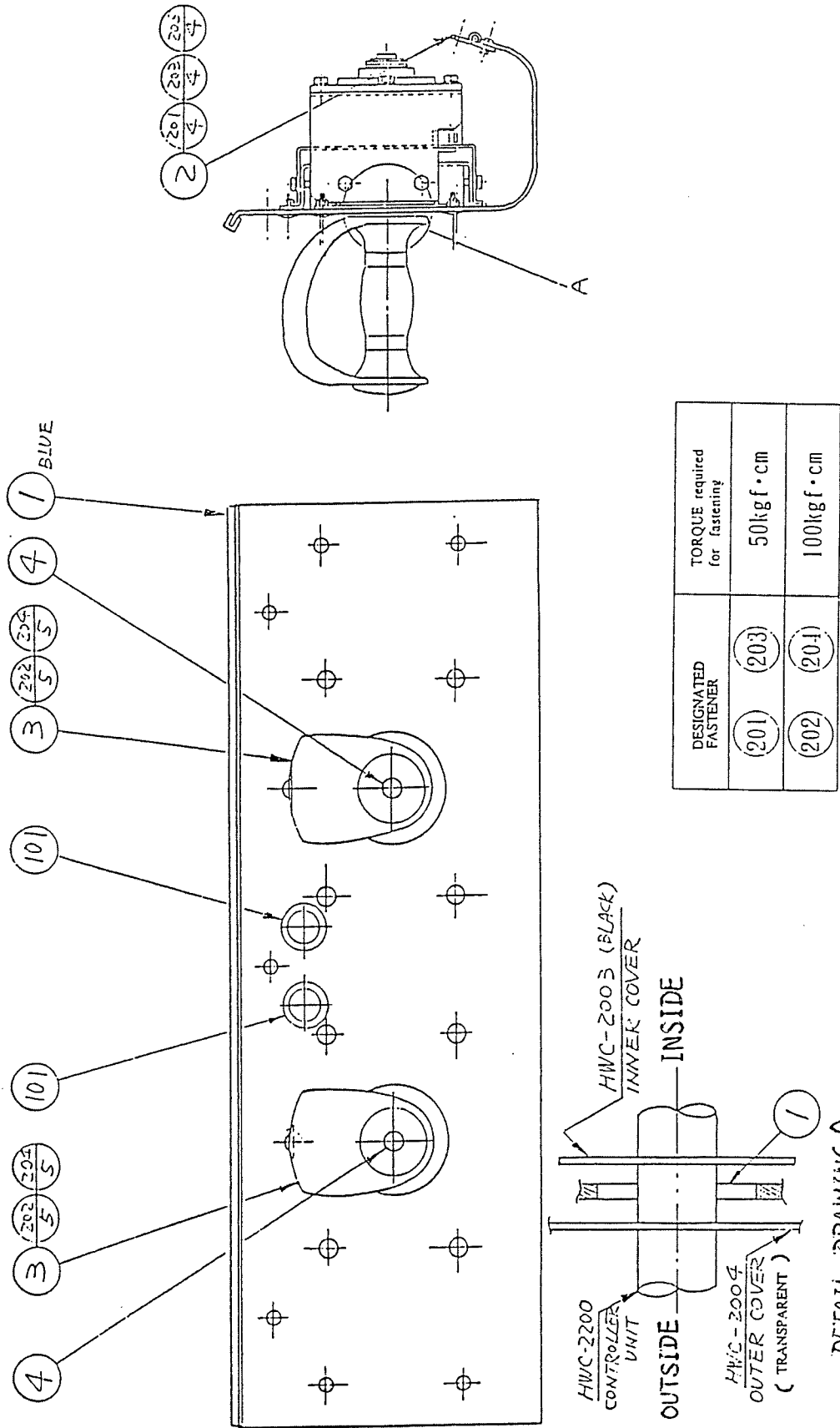

DETAIL DRAWING A

①⑥ ASSY CONT PNL RIGHT (HWC-2100)

(D-1/2)

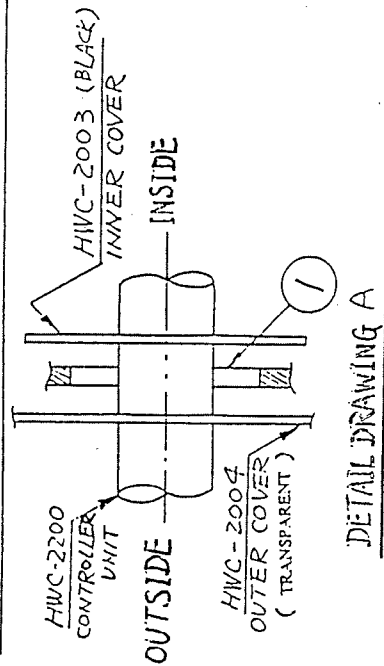
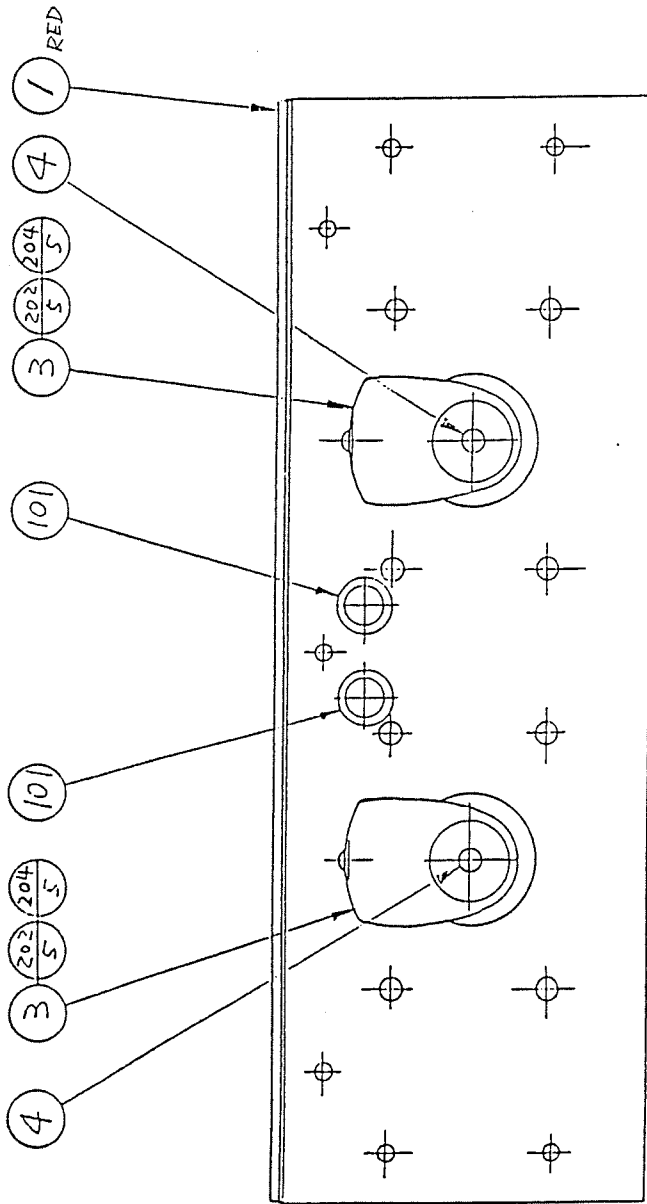
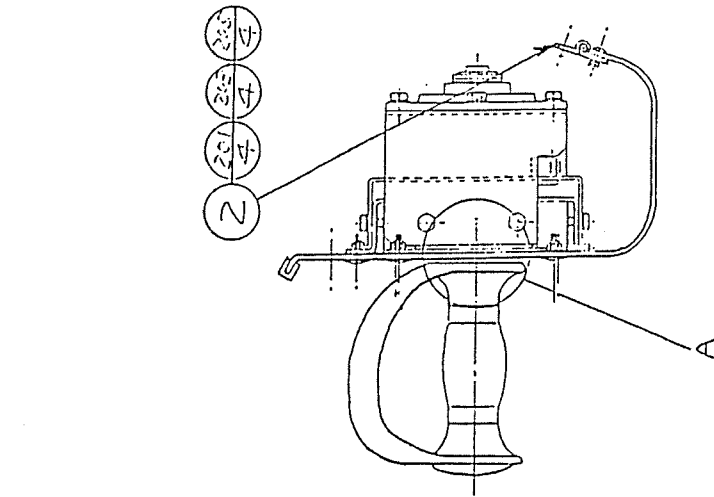

DESIGNATED FASTENER	TORQUE required for fastening
(201)	50kgf·cm
(202)	100kgf·cm
(203)	50kgf·cm
(204)	100kgf·cm

DETAIL DRAWING A



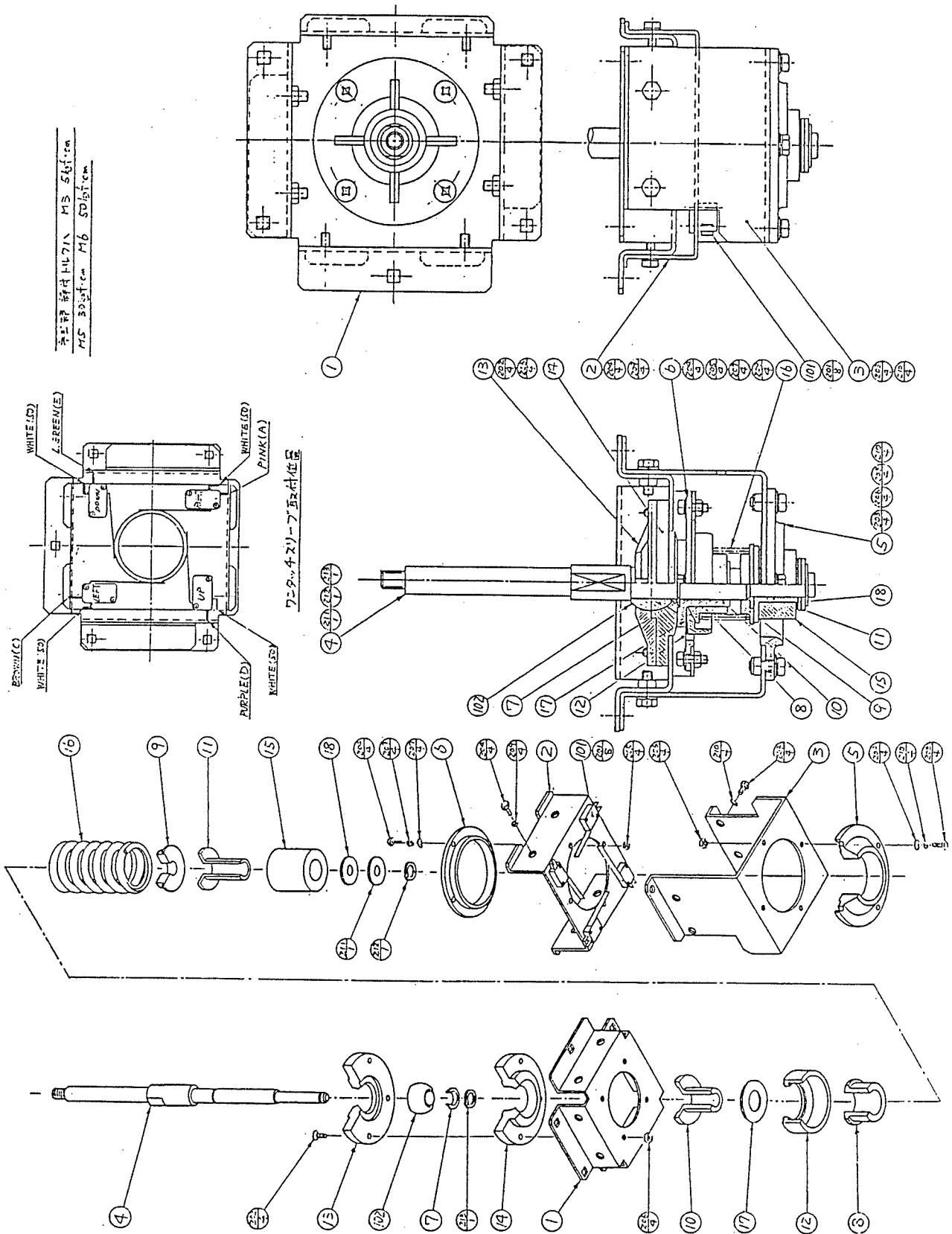

⑰ CONTROLLER UNIT (HWC-2200)

(D-1/3)





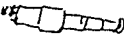

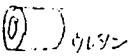

⑰ CONTROLLER UNIT (HWC-2200)

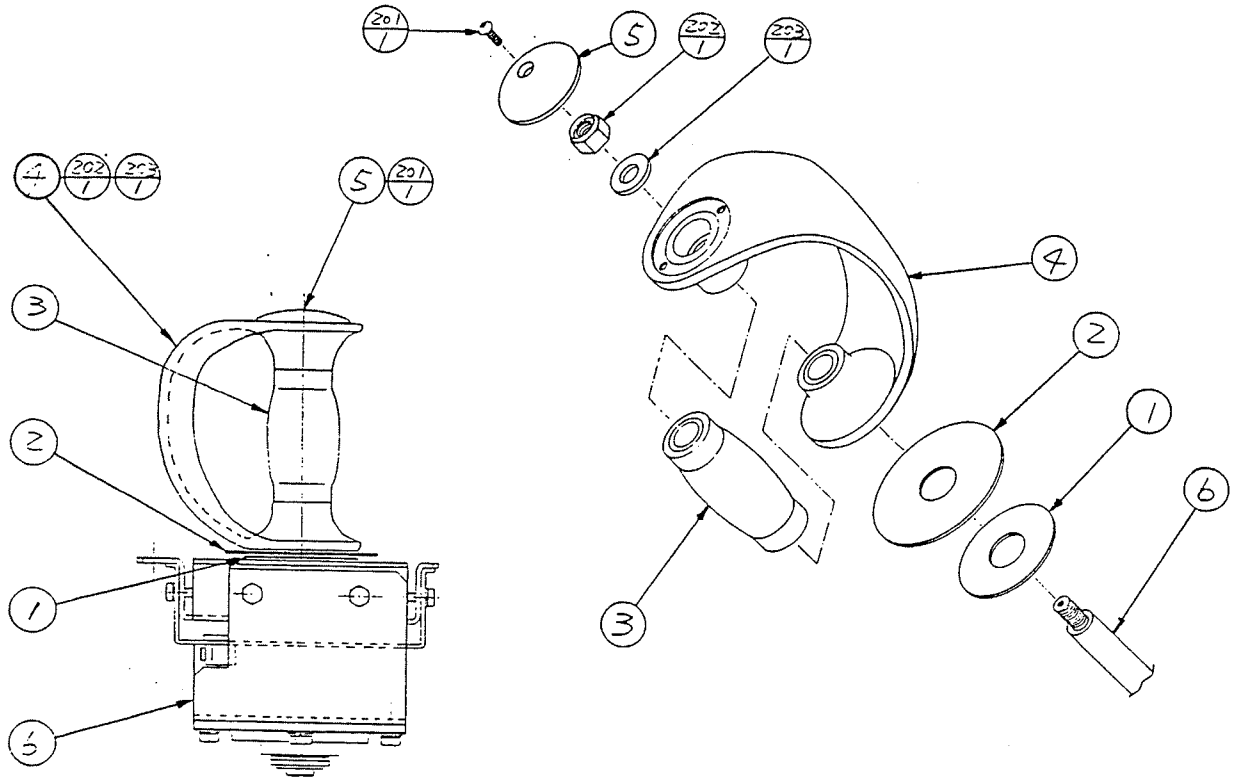
(D-2/3)

ITEM NO.	PART NO.	DESCRIPTION	NOTE
1	HWC-2201	HOLDER BRKT	
2	HWC-2202	SW BRKT	
3	HWC-2203	STOPPER BRKT	
4	HWC-2204	SHAFT	
5	HWC-2205	MAIN STOPPER	
6	HWC-2206	SUB STOPPER	
7	HWC-2207	COLLAR	
8	HWC-2208	PUSH SLEEVE	
9	HWC-2209	SPRING HOLDER	
10	HWC-2210	SLIDE SLEEVE	
11	HWC-2211	RUBBER HOLDER	
12	HWC-2212	CENTERING SLEEVE	
13	HWC-2213	BALL HOLDER UPPER	
14	HWC-2214	BALL HOLDER LOWER	
15	HWC-2215	RUBBER	
16	HWC-2216	COMP SPRING	
17	HWC-2217	SLIDE PLATE	
18	HWC-2218	SPACER	
101	509-5466	SW MICRO TYPE (AM50033C5)	
102	601-6997	BALL $\phi 31.75$	
103	280-0425	CORD CLAMP $\phi 10$	
104	601-0460	PLASTIC TIE BELT 100mm	
201	000-0316	M SCR PH M3 \times 16	
202	029-0446	M SCR FH M6 \times 20	

① ASSY CONTROLLER RED (HWC-2240)



ITEM NO.	PART NO.	DESCRIPTION	NOTE
1	HWC-2003	INNER COVER	 黒 ホリカホ
2	HWC-2004	OUTER COVER	 透明 ホリカホ
3	HWC-2005	GRIP RED	
4	HWC-2006	GRIP COVER RED	
5	HWC-2007	GRIP CAP RED	
6	HWC-2200	CONTROLLER UNIT	
201	008-0412	TMP PRF SCR TH M4×12	
202	059-0032	U NUT M10	
203	060-0010	FLT WSHR M10	



15. WIRE COLOR CODE TABLE

THE WIRE COLOR CODE is as follows :

A	PINK
B	SKY BLUE
C	BROWN
D	PURPLE
E	LIGHT GREEN

Wires other than those of any of the above 5 single colors will be displayed by 2 alphanumeric characters.

1	RED
2	BLUE
3	YELLOW
4	GREEN
5	WHITE
7	ORANGE
8	BLACK
9	GRAY

If the right-hand side numeral of the code is 0, then the wire will be of a single color shown by the left-hand side numeral (see the above).

Note 1 : If the right-hand side alphanumeric is not 0, that particular wire has a spiral color code. The left-hand side character shows the base color and the right-hand side one, the spiral color.

< Example > 51 WHITE / RED

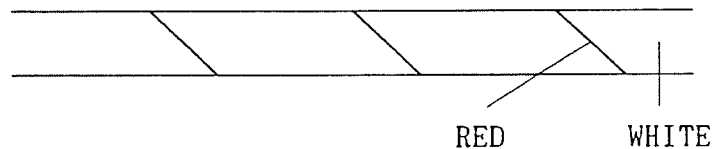

Note 1 : The character following the wire color code indicates the size of the wire.

K : A W G 18, U L 1015

L : A W G 20, U L 1007

None: A W G 22, U L 1007

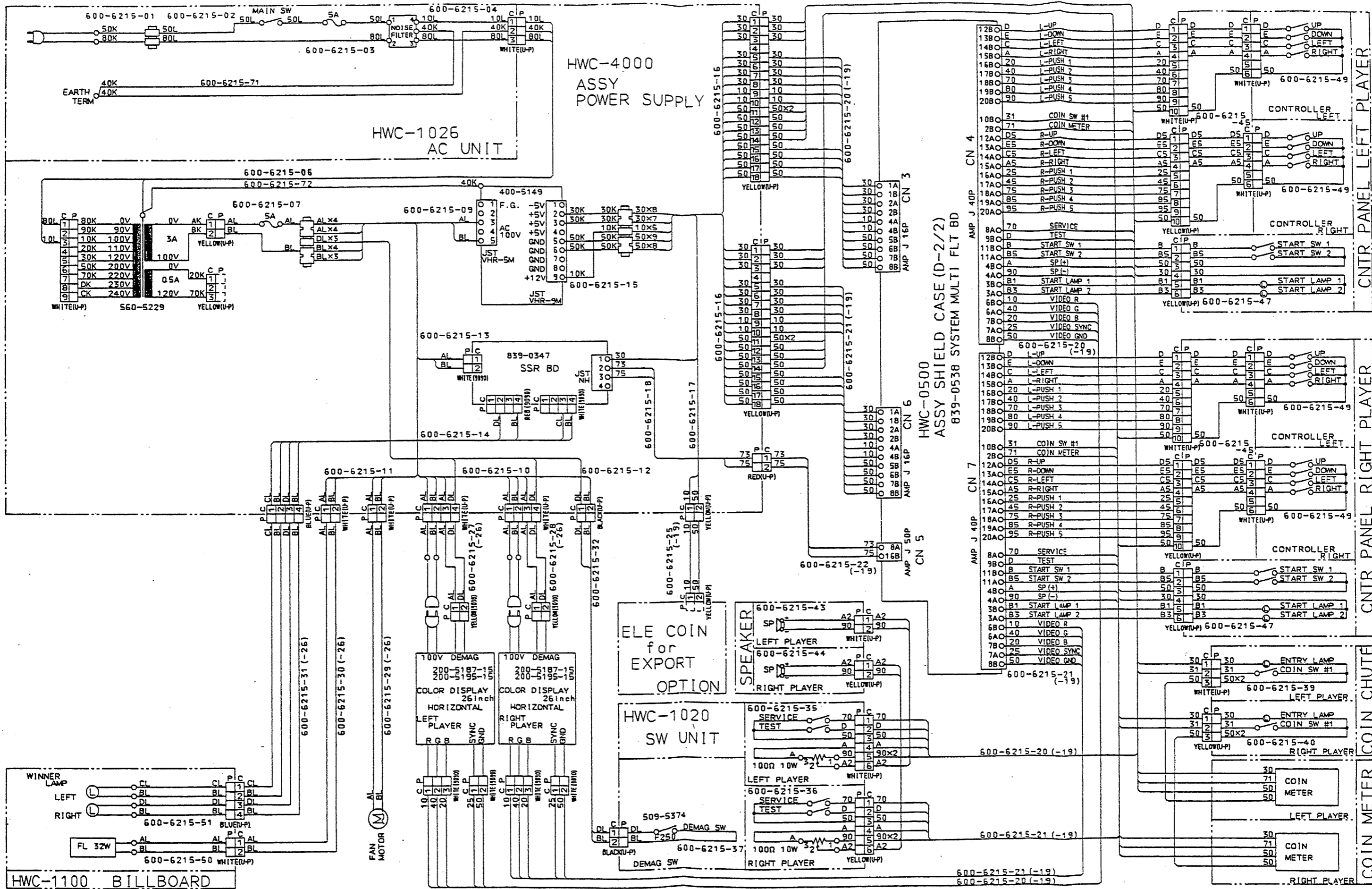

16. WIRING DIAGRAM (D-1/2)

HWC-0500
ASSY SHIELD CASE

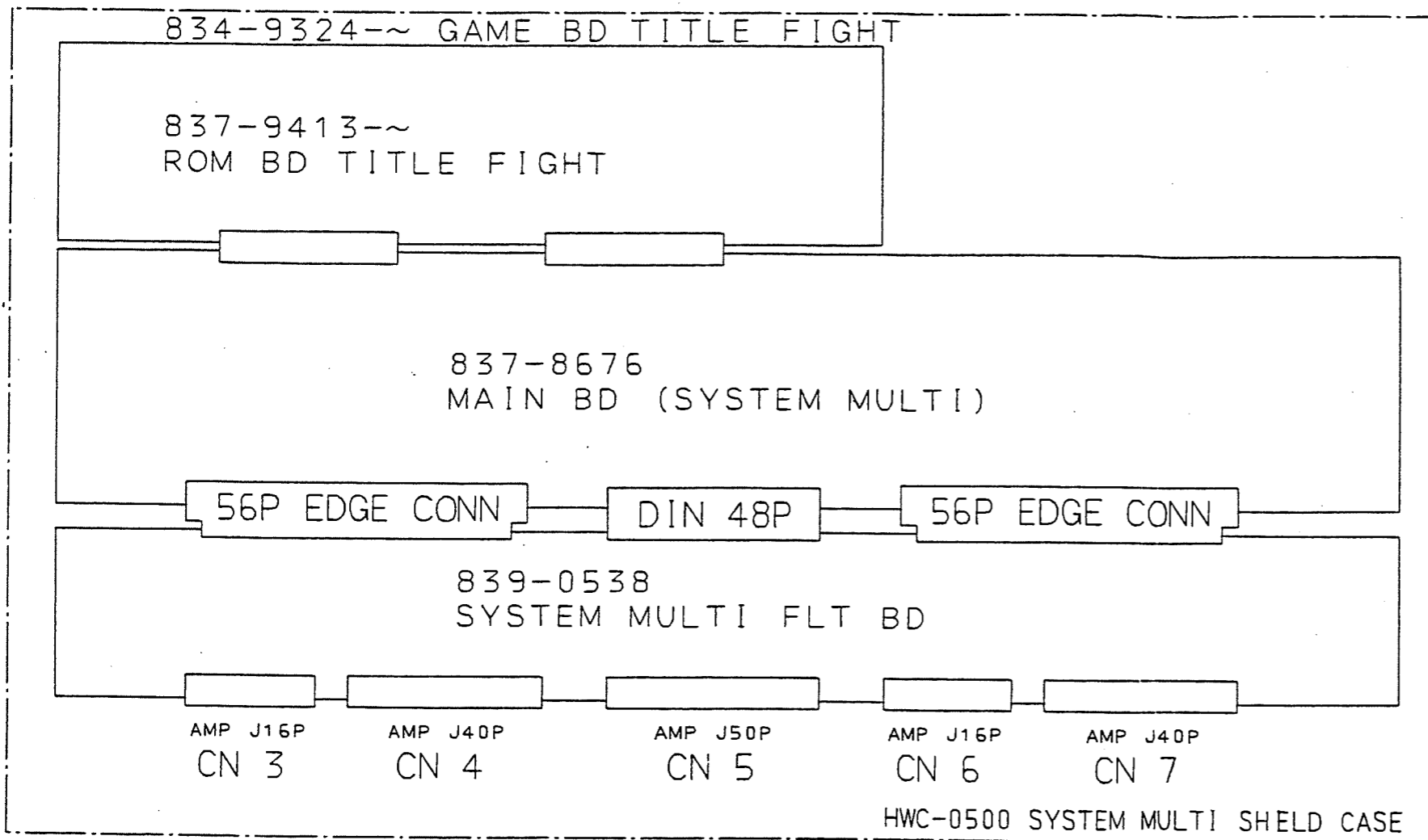

CONTROLL PANEL
HWC-2000, 2100

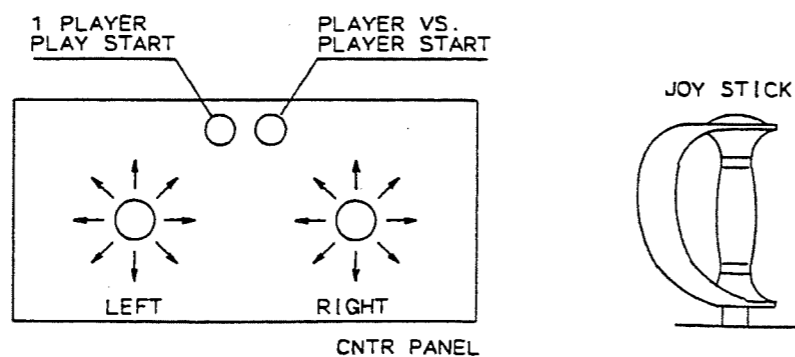

MARS COIN CHUTE

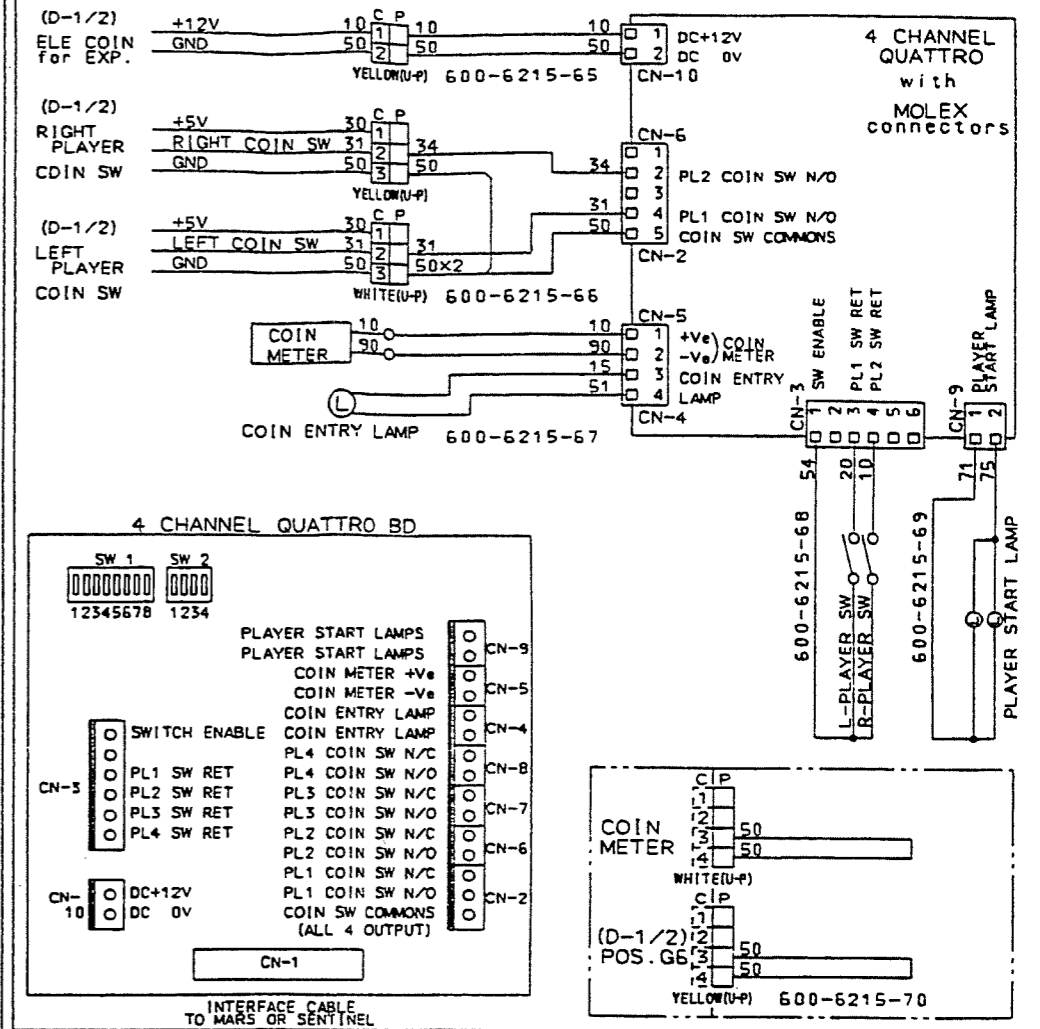

AC UNIT for EXPORT

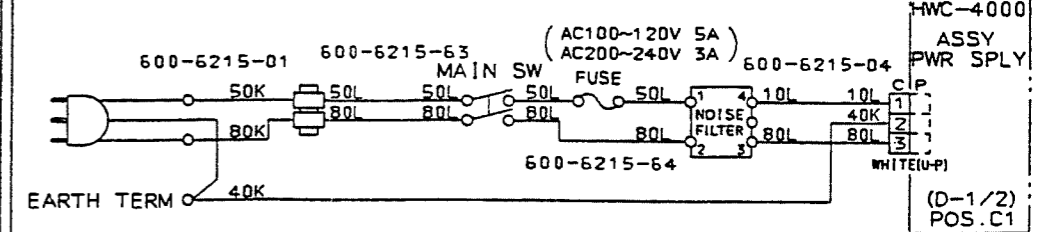

PWR TRANSFORMER WIRING

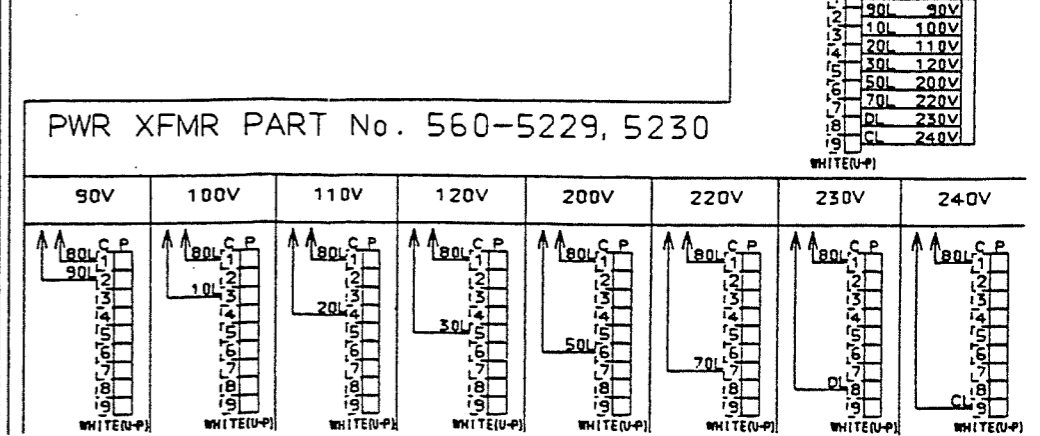

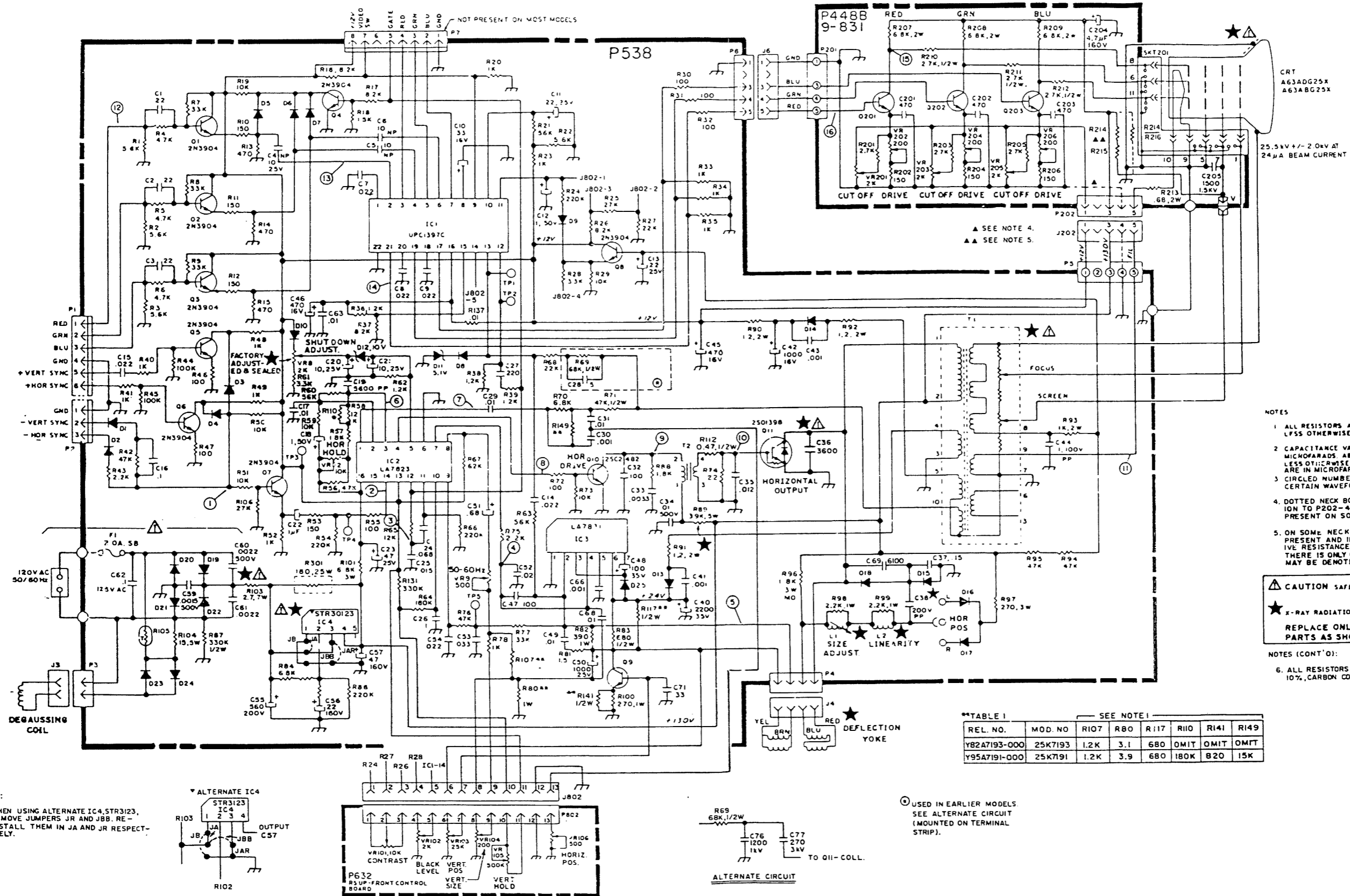

- NOTES
1. ALL RESISTORS ARE IN OHMS, 1/4W, 5% UNLESS OTHERWISE INDICATED.
 2. CAPACITANCE VALUES LESS THAN 1 ARE IN MICROFARADS. ABOVE 1 IN PICOFARADS UNLESS OTHERWISE INDICATED. ELECTROLYTICS ARE IN MICROFARADS.
 3. CIRCLED NUMBERS INDICATE LOCATIONS OF CERTAIN WAVEFORM READINGS.
 4. DOTTED NECK BOARD GROUND PATH (CONNECTION TO P202-4 AND P-5) MAY NOT BE PRESENT ON SOME VERSIONS.
 5. ON SOME NECK BOARDS, R214 AND R216 ARE PRESENT AND IN SERIES TO YIELD AN EFFECTIVE RESISTANCE OF 22M, 1W. ON OTHER BOARDS THERE IS ONLY ONE RESISTOR (22M, 1W) WHICH MAY BE DENOTED AS R214 AND R216.

CAUTION SAFETY CRITICAL COMPONENT.

X-RAY RADIATION RELATED COMPONENT.

REPLACE ONLY WITH SAME TYPE PARTS AS SHOWN IN PARTS LIST.

- NOTES (CONT'D):
6. ALL RESISTORS REFERRED TO IN NOTE 5. ARE 10% CARBON COMPOSITION.

SEE NOTE 1

REL. NO.	MOD. NO.	R107	R80	R117	R110	R141	R149
Y82A7193-000	25K7193	1.2K	3.1	680	OMIT	OMIT	OMIT
Y95A7191-000	25K7191	1.2K	3.9	680	180K	B20	15K

NOTE:
WHEN USING ALTERNATE IC4 STR3123, REMOVE JUMPERS JR AND JBB. RE-INSTALL THEM IN JA AND JR RESPECTIVELY.

