

**MIDWAY**

**September 1991  
16-43117-101**

# **SUREMAGET HIGHMAGET KIT**



## OPERATIONS MANUAL

- \* Kit Installation & Operation
- \* Testing & Problem Diagnosis
- \* PC Board Parts Information
- \* Wiring Diagrams & Schematics

## **SUPER HIGH IMPACT FOOTBALL**

### **Game Rules**

- 1 Player on a Team: You are a Quarterback & Defensive Captain.  
2 Players on a Team: Player 2 & 3 are Quarterbacks. Players 1 & 4 are Defensive Captains.

Start/Buy-in: Insert coin(s) and hit the Start Button for each coin.  
Stats: Enter Initials first to keep a running record of Achievement.

#### **OFFENSE**

Pass: Point Joystick to the Receiver, hit the Action Button.  
Handoff: Point Joystick to the Halfback, hit the Action Button.  
Spin Move: Hit the Action Button & move the Joystick up or down.  
Jump Move: Hit the Action Button & move the Joystick right or left.  
Kick: Tap the Action Button rapidly to increase distance.  
Fight: Tap the Action Button rapidly to raise the Meter: First to the Top, Wins the Fight.

#### **DEFENSE**

Select Player to Control: Hit Action Button Before Hike.  
Turbo Speed: Hold down the Action Button For Awesome Speed Burst.  
Killer Tackle: Hit the Action Button.  
Interception: Hit the Action Button before the Leaping Catch.  
Block Kick: Hit the Action Button.  
Hit-O-Meter: Bigger awards for Bigger Hits.

**! CARD DISPENSER FEATURE IS NOT AVAILABLE FOR KITS !**



**SUPER  
HIGH IMPACT  
FOOTBALL  
KIT**

# TABLE OF CONTENTS

## **Section 1 Operation and Troubleshooting**

<b>Safety</b> .....	1-2
<b>Conversion Procedure</b>	
Inspection.....	1-3
Cabinet & Control Panel Modifications.....	1-4
Suggested Template Layout.....	1-6
Suggested Control Panel Layout.....	1-7
Decal Sets.....	1-8
Installing PC Boards into a JAMMA Cabinet.....	1-9
Installing PC Boards into a Non-JAMMA Cabinet.....	1-10
<b>Game Features</b>	
Starting-up.....	1-11
Player Controls.....	1-11
Typical Control Panel .....	1-11
<b>Game Operation</b>	
Control Switches.....	1-12
Control Switch Location Diagram.....	1-12
<b>Menu System Operation</b>	
Operation.....	1-13
Main Menu.....	1-13
Diagnostic Tests.....	1-14
Switch Test.....	1-14
DIP Switch Test & Table.....	1-15
CPU & Sound Tests.....	1-16
Monitor Patterns .....	1-17
Burn-in Tests.....	1-18
Coin Bookkeeping.....	1-19
Game Audits.....	1-20
Game Adjustments.....	1-21
Standard Pricing Table.....	1-23
Custom Pricing Table.....	1-24
<b>Utilities</b> .....	1-25
<b>Troubleshooting</b> .....	1-26

## **Section 2 Parts Information**

CPU Board Assembly.....	2-2
CPU Board Parts.....	2-3
Sound Board Assembly.....	2-4
Sound Board Parts.....	2-5

## **Section 3 Diagrams and Schematics**

Coin Meter Wiring.....	3-3
JAMMA Chart.....	3-4
Cabinet Wiring.....	3-5
Control Panel Wire List.....	3-6
Jumper Wire List.....	3-7
Interboard Wiring.....	3-8
Sound Board Schematic.....	3-9
CPU Board Schematic.....	3-10
Copy of Player 1 Template.....	1
Copy of Player 2 Template.....	2
Copy of Player 3 Template.....	3
Copy of Player 4 Template.....	4

# **SUPER HIGH IMPACT FOOTBALL KIT**

**S E C T I O N  
one**

---

**Operation & Installation**

## Safety Notices

The following safety hints apply to all kit operators and service personnel. Specific warnings and cautions will be found throughout this manual where they apply. We recommend that you read this page, and also all of Section 1, before preparing your kit for play.



### Notice: Salvaged Parts

Parts salvaged from old games are required to complete your kit. These salvaged parts must operate perfectly; otherwise, the converted game cannot perform properly or safely. Always repair circuit board malfunctions and cabinet damage before conversion is attempted.

### Notice: Power Supply

Be sure the power supply from your old game is capable of +5V dc at 5A, -5V dc at 1A and +12V at 1A. These operating voltages are necessary for your kit. Your power supply must be FCC approved.

### Notice: Monitor

This kit is not intended for use with X-Y monitors. Suitable monitors have horizontally mounted CRTs and raster electronics with inputs for red, green and blue video, as well as Composite Negative Sync inputs.

### Notice: Coin Mechanism

Be sure to clean and lubricate your old coin mechanisms. Servicing them is crucial to your game's earning potential and operation.

### Notice: Coin Meters

Coin meters are not provided with this kit. Wiring information is provided as a convenience to the operator.

### Notice: Servicing, Installing

Always turn your game Off and unplug it before attempting to service or install your kit.

## ATTENTION !

**PROPERLY ATTACH ALL CONNECTORS.** *Be sure that the connectors on each printed circuit board (PCB) are properly connected. If they do not slip on easily, do not force them. A reversed connector may damage your kit and void the warranty. All connectors are keyed to fit specific pins on each board.*

---

---

## Conversion Procedure

### Inspection

Unpack the materials from the carton and inspect for obvious signs of damage. Use this checklist to be sure your kit is complete.

Part No.	Item	Quantity
<input type="checkbox"/> A-13234-40017	CPU board	1
<input type="checkbox"/> A-13971-40017	Sound board	1
<input type="checkbox"/> H-8865-4	Volume Control Cable	1
<input type="checkbox"/> H-12758	Sound Board Jumper Cable	1
<input type="checkbox"/> H-13257	Sound/Power Speaker Cable	1
<input type="checkbox"/> H-13411	Main Jumper Cable	1
<input type="checkbox"/> H-13724	Player 3 & 4 Cable	1
<input type="checkbox"/> 16-9192	Controls Template	1
<input type="checkbox"/> 16-9192-1	Controls Template P2	1
<input type="checkbox"/> 16-9192-2	Controls Template P3	1
<input type="checkbox"/> 16-9192-3	Controls Template P4	1
<input type="checkbox"/> 16-9207	Start-up Instruction Decal	1
<input type="checkbox"/> 16-43117-101	Manual	1
<input type="checkbox"/> 20-9319-1	8-way Joystick, Red	2
<input type="checkbox"/> 20-9319-9	8-way Joystick, Blue	2
<input type="checkbox"/> 20-9687-1	Pushbutton, Red	2
<input type="checkbox"/> 20-9687-2	Pushbutton, White	4
<input type="checkbox"/> 20-9687-3	Pushbutton, Blue	2
<input type="checkbox"/> 31-1612-43117	Control Panel Overlay	1
<input type="checkbox"/> 31-1616-43117	Cabinet Side Decal	2
<input type="checkbox"/> 31-1617-43117	Card & Controls Decal	1
<input type="checkbox"/> 31-1644-40017-1	Marquee	1
<input type="checkbox"/> 5795-10937-18	20-pin Ribbon Cable	1
<input type="checkbox"/> Assorted Hardware		

### Recommended Tools and Supplies

- black semi-gloss paint
- electric drill
- electric screwdriver
- grease pencil or marker
- hex driver
- 180 grit sandpaper or electric sander
- pliers
- razor knife
- soldering iron and solder
- wire cutters
- black electrical tape
- quick-hardening wood putty

## Cabinet Modifications

1. Fill in gouges with a good quick-hardening wood putty. Sand cabinet and wipe it clean.
2. Repaint the cabinet with black semi-gloss paint (Games wood grain sides: remove the old decals and clean the glue residue from the old decal before painting). Allow paint to dry completely.
3. Pencil a line roughly at the top of the old graphic. Lightly moisten the cabinet with soapy water. Apply the decal starting at the top and working down. After the decal is in place, smooth it down, taking care to squeeze out the air bubbles. If you miss an air bubble, pop it with a razor blade or a pin and burnish it down. Allow 12 hours for the adhesive in the decals to set. Remove masking.
4. Check the kit for an FCC sticker and apply it over the existing sticker on the cabinet.

**When Midway ships a game, it is in compliance with FCC regulations. Your sticker is proof. If the sticker is missing or damaged, legal repercussions to the owner or distributor of the game may result. If your game kit does not contain an FCC sticker, call Midway Manufacturing immediately.**

5. Apply the Game Play Instruction Decal to the CRT viewing glass. Be sure the decal does not obstruct the CRT.

## Control Panel Modifications

1. Remove the control panel buttons and joysticks and remove the old vinyl covering.
2. Use the Control Panel Templates to help you design your control panel. You will need to use a separate template for each player you intend to install. Refer to page 1-6 for suggested template layouts.
3. Drill Holes as needed for the joysticks and control panel buttons. Plug previous holes with wood blocks, putty, cardboard or epoxy. File the new holes smooth.
4. Carefully remove the backing on the vinyl control panel overlay. Place the overlay on top of the control panel. Prevent air bubbles from getting under the vinyl overlay.



5. a) After the overlay is on securely, use a razor knife to cut holes for the control panel buttons and joysticks.  
b) Position the stickers around the appropriate locations. Refer to pages 1-7 & 1-8 for suggested control panel button and joystick sticker locations.
6. Next mount the pushbutton switches onto the control panel. Remove the switch from the pushbutton: Grasp the switch firmly on the left and right sides and squeeze the prongs together, (do not grasp the switch by the solder lugs). Carefully, pull the switch off the housing. Unscrew the nut from the housing. Push the switch housing through the control panel from the front. Screw the nut back onto the switch housing from the back of the control panel. Carefully, push the switch back into the switch housing.
7. To mount the joystick assembly to the control panel first position the switch assembly so that the square base is against the back of the control panel and the hole in the base lines up with the joystick hole in the control panel. Be sure that one of the blade switches point toward the monitor when the control panel is closed. Secure the switch assembly to the control panel. Remove the "E"-ring, white plastic spacer and spring from the joystick shaft. Slip the black plastic washer around the joystick shaft so the rough side faces the handle. Push the shaft through the joystick base from the front of the control panel. After the shaft is through the base, replace the spring, spacer and "E"-ring.
8. Mount the volume control, using the screws provided, where it is easily accessible. On top of the cash box, or on the wall near the sound board are two possible locations.



### Suggested 4-player Control Panel Layout

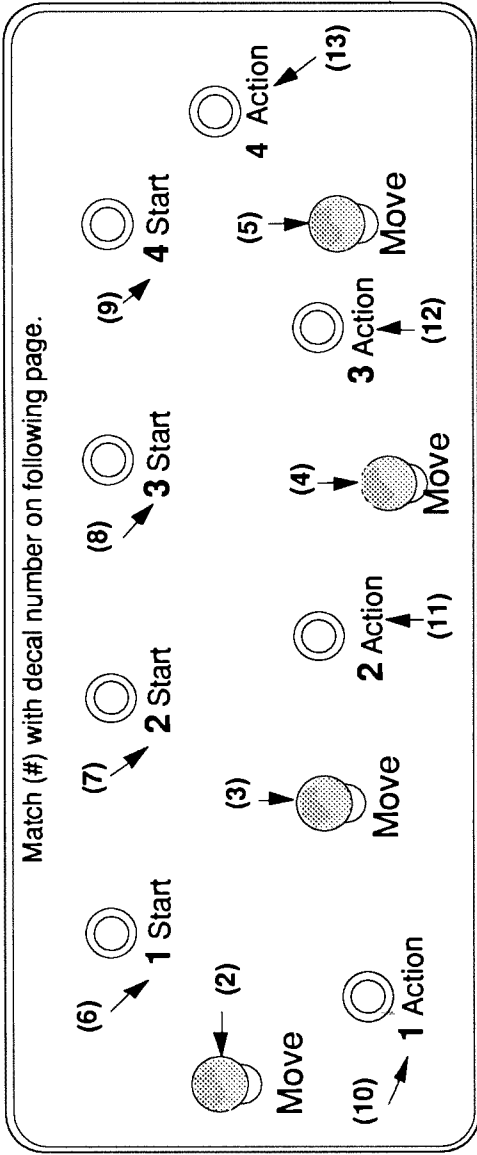

### Suggested 2-player Control Panel Layout

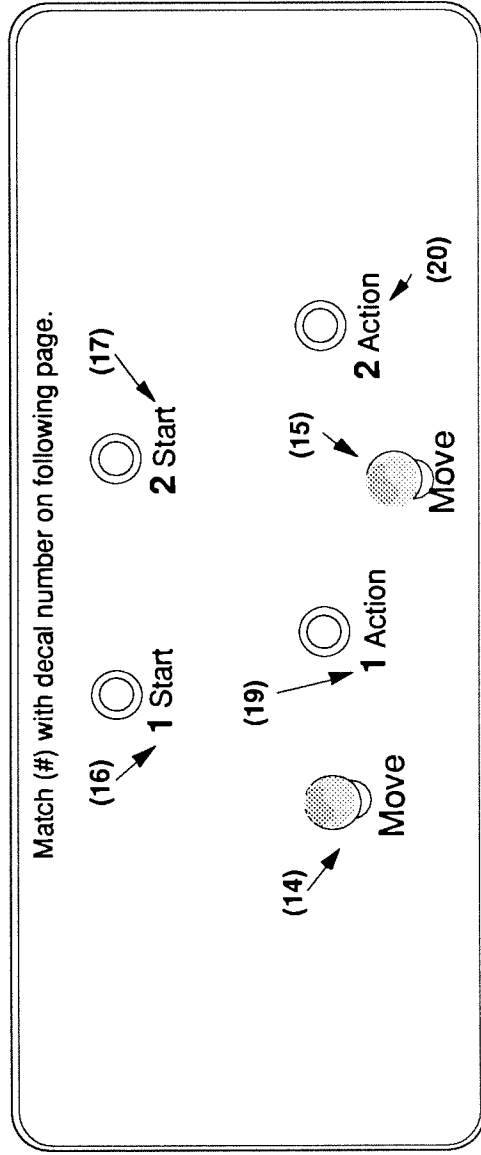

## Decal Sets

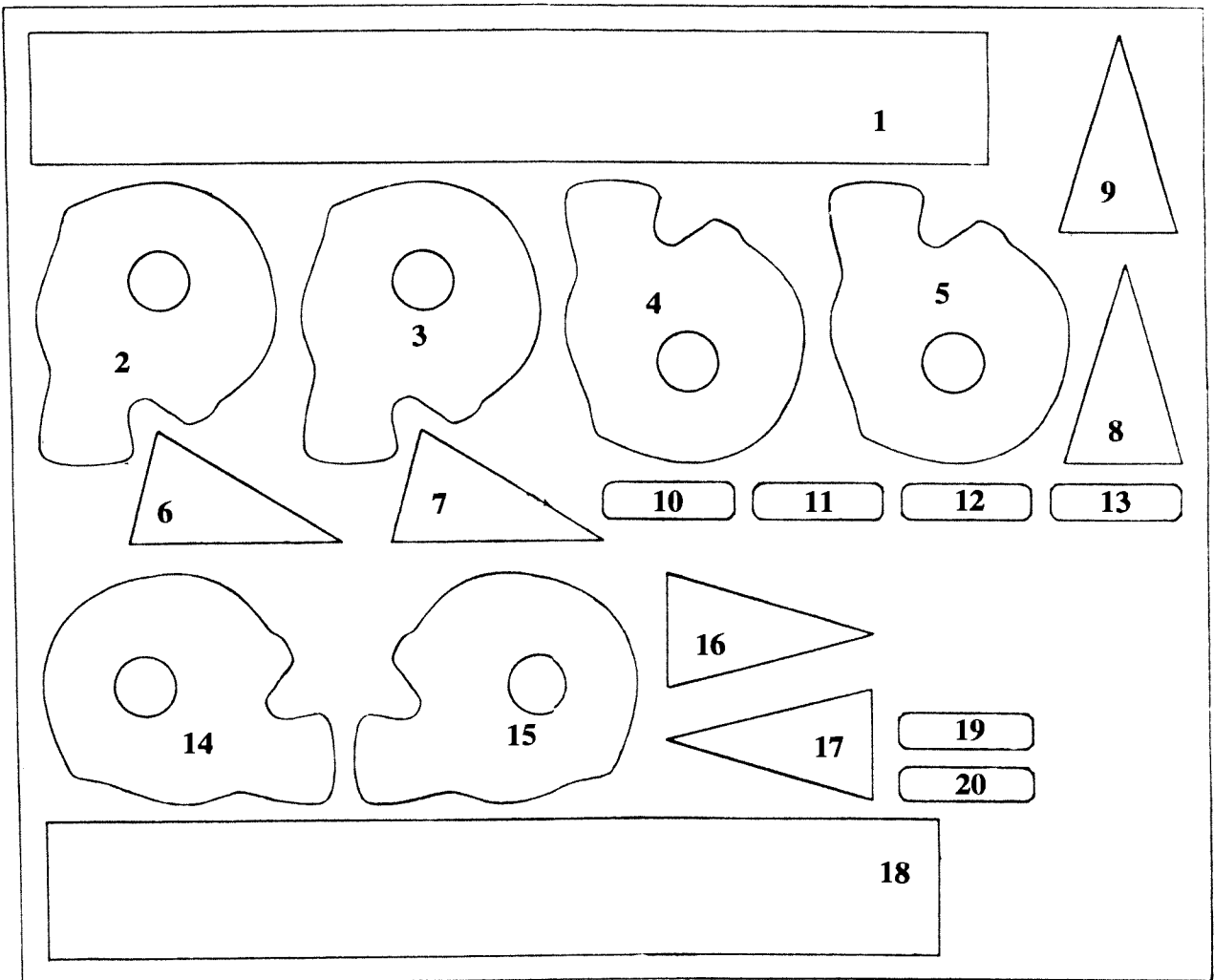

### 4 PLAYER DECAL SET:

- (1) Four Player Instruction Card
- (2) Player One Defensive Captain (Red)
- (3) Player Two Quarterback (Red)
- (4) Player Three Quarterback (Blue)
- (5) Player Four Defensive Captain (Blue)
- (6) Start Player One (Red)
- (7) Start Player Two (Red)
- (8) Start Player Three (Blue)
- (9) Start Player Four (Blue)
- (10) Action (Red)
- (11) Action (Red)
- (12) Action (Blue)
- (13) Action (Blue)

### 2 PLAYER DECAL SET:

- (14) Player One Quarterback (Red)
- (15) Player Two Quarterback (Blue)
- (16) Start Player One (Red)
- (17) Start Player Two (Blue)
- (18) Two Player Instruction Card
- (19) Action (Red)
- (20) Action (Blue)

## Installing the PC Boards and Wiring into a JAMMA Game Cabinet

1. Disconnect and remove the existing CPU board in the JAMMA game cabinet.
2. Mount the CPU board inside the JAMMA game cabinet where the old CPU board was located. Mount the sound board next to the CPU board using the stand-offs and screws provided.
3. If you choose to use the JAMMA cable provided with the kit, unsolder your old JAMMA cable from the speaker, power supply, control panel switches (may already be disconnected) and coin door. Remove the cable from the game. If you are not going to use the JAMMA Cable provided with the kit, check the JAMMA Cable Chart to be sure your cable is compatible. Leave your power supply chassis as is.
4. Connect the JAMMA cable to J1 on the CPU board. Using the JAMMA Cable Chart or the Cabinet Wiring Diagram for reference, solder the correct JAMMA cable wires to the speaker, power supply and the coin door. When connecting the player 1 & 2 control panel button and joystick switches, be sure to connect the correct wires to the correct switch. Player 1 has orange-color stripe wires while Player 2 has yellow-color stripe wires. Follow the Control Panel Wire Color List or the Cabinet Wiring Diagram, both in Section 3 of this book.
5. To use Players 3 & 4 you need to connect a separate cable. Player 3 connects from J4 of the CPU Board and has red-color stripe wires. Player 4 connects from J12 of the CPU Board and has blue-color stripe wires. Be sure to connect the correct wire to the correct control panel or joystick switch. Follow the Control Panel Wire Color List or the Cabinet Wiring Diagram, both in Section 3 of this book.
6. Connect the ribbon cable from J4 on the sound board to J8 on the CPU board. Be sure that the red line goes to the same pin on both boards. Connect the wire harness cable from J5 (speaker), and J3 (power), on the sound board to J2 (sound power speaker connector) on the CPU board.
7. J6, J7, J9 on the CPU board are not used.
8. Place the FBI Warning Label on the inside of the cabinet next to the PC boards. Be sure the label is completely visible.

### Note

If you choose to use your own JAMMA Cable and not the one provided in the kit, be sure to check the JAMMA Cable Chart to verify that it is compatible.

### Caution

Properly insulate any unused wires within the JAMMA cable, especially the gray, gray-green and gray-yellow wires. This is a fully wired JAMMA cable. Many of the wires will not be used for this kit. These wires have been installed so that you can use this cable for future kits.

### Note

The ribbon cable may need to be twisted in order to connect it properly.

## Installing the PC Boards and Wiring into a NON-JAMMA Game Cabinet.

1. Disconnect and remove the existing CPU board in the game cabinet.
2. Mount the CPU board inside the game cabinet where the old CPU board was removed. Mount the sound board next to the CPU board using the stand-offs and screws provided.
3. Leaving several inches of wire, cut the wires at the coin door, control panel switches (which may already be disconnected) speaker and power supply.
4. Connect JAMMA cable to CPU board at J1. Follow the JAMMA Cable Chart or the Cabinet Wiring Diagram and splice the wires of the JAMMA cable to the existing wires for the coin door, power supply, and speaker. When soldering Player 1 & 2 control panel button and joystick switches, be sure to connect the correct wire to the correct blade switch. Player 1 has orange-color stripe wires while Player 2 has yellow-color stripe wires. Follow the Control Panel Wire Color List or the Cabinet Wiring Diagram. Be sure all of the spliced wires are well insulated with black electrical tape.
5. To use Players 3 & 4 you need to connect a separate cable. Player 3 connects from J4 of the CPU Board and has red-color stripe wires. Player 4 connects from J12 of the CPU Board and has blue-color stripe wires. Be sure to connect the correct wire to the correct control panel or joystick switch. Follow the Control Panel Wire Color List or the Cabinet Wiring Diagram, both in Section 3 of this book.
6. Connect the ribbon cable from J4 on the sound board to J8 on the CPU board. Be sure that the red line goes to the same pin on both boards. Connect the wire harness cable from J5 (speaker), and J3 (power) on the sound board to J2 (sound power speaker connector) on the CPU board.
7. J6, J7, J9, on the CPU board are not used.
8. Place the FBI Warning Label on the inside of the cabinet next to the PC boards. Be sure the label is completely visible.

### Note

Be sure all spliced wires are well insulated with black electrical tape.

### Caution

Properly insulate any unused wires within the JAMMA cable, especially the gray, gray-green and gray-yellow wires. This is a fully wired JAMMA cable. Many of the wires will not be used for this kit. These wires have been installed so that you can use this cable for future kits.

### Note

The ribbon cable may need to be twisted in order to connect it properly.

---

---

## Game Features

### STARTING UP

Switch on power to the game. A "rug" pattern appears on the CRT screen. When the "rug" pattern ends, the screen shows CHECKING SCRATCH RAMS, and then CHECKING ROMS. The next screen shows SUPER HIGH IMPACT FOOTBALL REVISION LEVEL, CMOS TEST OK and the COIN SETTING. The game then moves to the Attract Mode.

#### Note

When an error is detected during Start-up Tests, game start-up does not progress, and an error message appears on the screen.

Insert the desired amount of coins or tokens. Select which player receives the credit by pressing the appropriate Player Start Button. Continue pressing the Player Start button until all credits are used. The game begins to play after the last credit has been assigned a player.

### PLAYER CONTROLS

#### ■ Start Button

Each Start Button allows one to four players to begin or continue play.

#### ■ Action Button

Each player's Action Button controls the operation (Jump, Kick, Interception, etc) of their on screen player.

#### ■ Joystick

Each player's Joystick moves (Up, Down, Left, Right, etc) their on screen player.

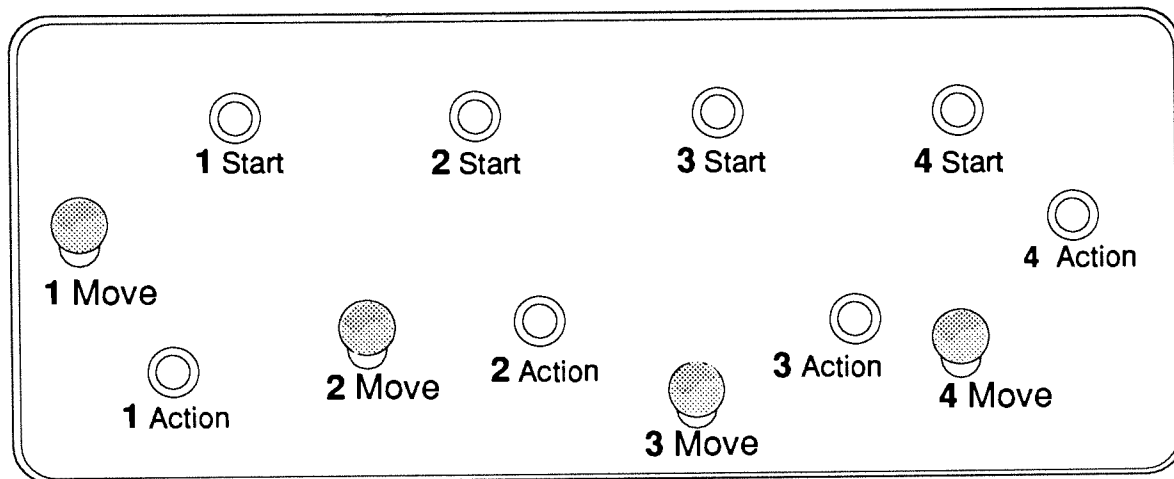

Typical 4-player Control Panel Layout

---

---

## Game Operation

The SUPER HIGH IMPACT FOOTBALL Control Switches are located inside the coin door. These switches allow the operator to customize some features of the game.

### CONTROL SWITCHES

- The **COIN DOOR SLAM TILT SWITCH** detects any forceful vibrations against the Coin Door. This eliminates pounding for free games. (Optional Switch.)
- The **VOLUME CONTROL** allows increasing or decreasing the volume level of the game music and speech. For greater profits, set your game's volume level at its maximum.
- The **TEST/DIAGNOSTICS SWITCH** allows you to activate the game's Menu System. Move the Test Switch to access the Main Menu. To exit the Menu System, select EXIT TO GAME OVER from the Main Menu, then press any control panel button. (Optional Switch.)
- The **SERVICE CREDIT SWITCH** is a special feature switch that allots credit without affecting the game's bookkeeping total. (Optional Switch.)

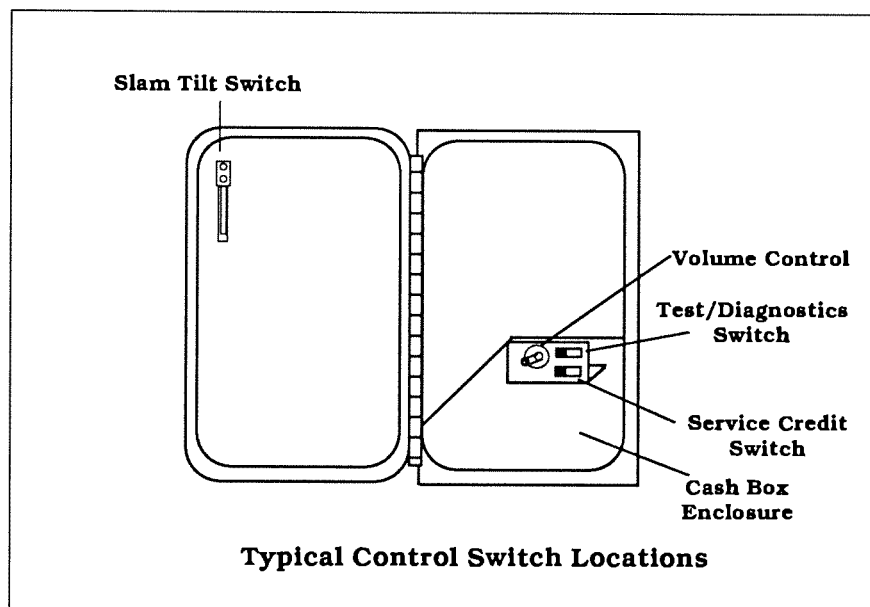



---

---

## Menu System Operation

### OPERATION

All SUPER HIGH IMPACT FOOTBALL Game Audits, Adjustments, and Diagnostics are options of the Main Menu. Each option, in turn, has its own menu, listing several choices that you may act upon as desired.

Move the Test Switch (if you have installed it), or close Switch #8 of DIP Switch Bank #2, to activate the Main Menu (shown below). Game adjustments, bookkeeping, and diagnostics are all accessible from this menu.

Move any joystick up or down to cycle through the menu options. Notice that the options are highlighted in sequence. Press any control panel button to activate a highlighted option.

**Note:** Only highlighted options can be activated.

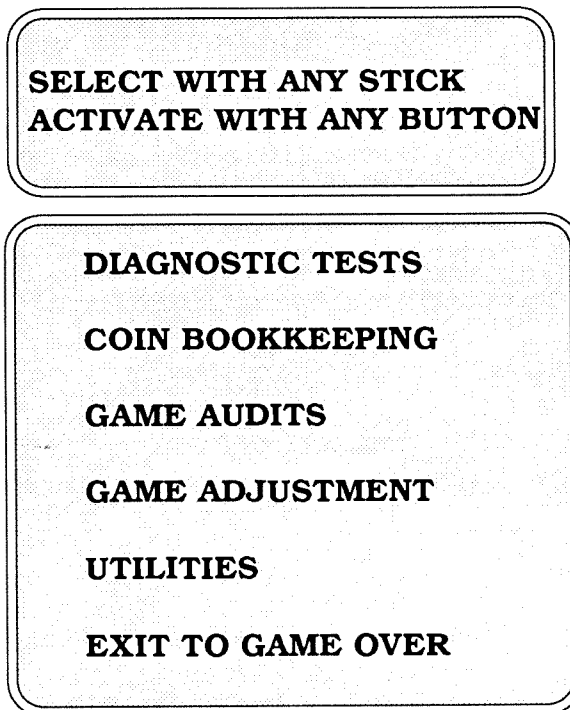

**Main Menu**

## **DIAGNOSTIC TESTS**

To enter the Diagnostic Tests from the Main Menu, move any joystick to select (highlight) the Diagnostic Test option, and press any control panel button to activate the option.

**SELECT WITH ANY STICK  
ACTIVATE WITH ANY BUTTON**

**SWITCH TEST  
DIP SWITCH TEST  
CPU BOARD TEST  
SOUND BOARD TEST  
MONITOR PATTERNS  
CARD DISPENSER TEST\*  
BURN-IN TEST  
RETURN TO MAIN MENU**

### **Diagnostic Menu**

#### **Switch Test**

The Switch Test allows the operator to test the switches on the control panel and the coin door.

Select the Switch Test by using any joystick to highlight the Switch Test option; then, press any control panel button to activate it. The top of the screen shows a layout of the control panel and the bottom of the screen lists the coin door switches. Pressing a switch causes the corresponding switch location on the screen to light. Release the switch and the screen returns to normal.

Press the Player 1 & 2 Start Buttons together to return to the Diagnostic Menu.

**\* Available in Upright Dedicated Games Only.**

## DIP Switch Test

The DIP Switch Test allows the operator to check the position of the two 8-position DIP Switches on the CPU Board. The operator can also change the setting of each position of each DIP Switch during this mode.

Use any joystick to select the DIP Switch Test and any control panel button to activate it. The screen displays a layout of their current settings.

To change a DIP Switch setting, press the switch to the desired setting, then check the screen to verify that the switch now shows the new setting.

Press any control panel button to return to the Diagnostic Menu.

### DIP Switch 1 Settings Table

	SW 1	SW 2	SW 3	SW 4	SW 5	SW 6	SW 7	SW 8
4 Player 2 Player	Off * On							
CMOS Coinage DIP Switch Coinage		On Off *						
<b>Coin Settings</b>								
USA 1	Ger 1	Fr 1	Off *	Off *	Off *			
USA 2	Ger 2	Fr 2	On	Off	Off			
USA 3	Ger 3	Fr 3	Off	On	Off			
USA 4	Ger 4	Fr 4	On	On	Off			
USA ECA	Ger ECA	Fr ECA	Off	Off	On			
N/U	N/U	N/U	On	Off	On			
N/U	N/U	N/U	Off	On	On			
N/U	Free Play	Free Play	On	On	On			
<b>Card Dispenser **</b>								
Enabled								Off
Disabled								On*

### DIP Switch 2 Settings Table

	SW1	SW2	SW3	SW4	SW5	SW6	SW7	SW8
USA	Off *	Off *						
German	On	Off						
French	Off	On						
Not Used	On	On						
Not Used			Off *					
One Counter Two Counters				Off * On				
Not Used								
Not Used								
<b>Test Switch</b>								Off *
Game Mode								On
Test Mode								

\* Indicates Factory Setting. \*\* Available in Dedicated Upright Games Only.

**Note**

As soon as a faulty chip is detected, the CPU Test stops. The remaining chips are not tested.

**CPU Board Test**

The CPU Board Test (much like the Start-up Test) allows the operator to check the RAMs and ROMs.

Select the CPU Board Test with any joystick; then, press any control panel button to activate the automatic test of the CPU Board's RAMs and ROMs. When this test is activated, a "rug" pattern appears on the screen. The screen then changes to show the layout of the RAMs, and ROMs on the CPU. Any chip that is shown as black with a white outline is part of the CPU and should turn either red or green during the CPU Test. Any chip that is shown as gray with a white outline is not installed in the game. During the test, chips are good, if they turn green; they are faulty, if they turn red.

**Sound Board Test**

The Sound Test allows listening to some of the sounds that SUPER HIGH IMPACT FOOTBALL is capable of producing. This test also emits a tone for each fault that is detected.

Select the Sound Board Test with any joystick; then, press any control panel button to activate the test. The screen displays two test options:

**GENERAL TEST** analyzes the sound circuitry. A successful test causes a single "tone" to sound. Detection of a fault causes a series of tones or no tone at all to sound.

**PLAY SOUNDS** tests synthesized & digitized sounds from the Sound Board. Advance to the next sound by moving any joystick, and press any control panel button to activate the sound.

Select RETURN TO MAIN MENU or BACK TO DIAGNOSTIC MENU. Press any control panel button to activate your selection.

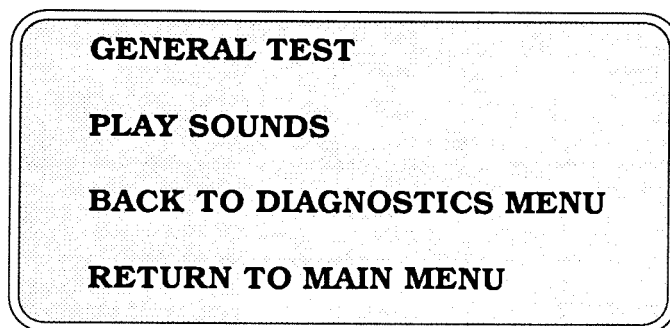

**Sound Test Menu**

## Monitor Patterns

The Monitor Patterns Test provides a menu for testing the monitor. Select the test with any joystick and activate with any control panel button. Once the Monitor Test is activated, move any joystick to select a Monitor Test option; press any control panel button to activate the option.

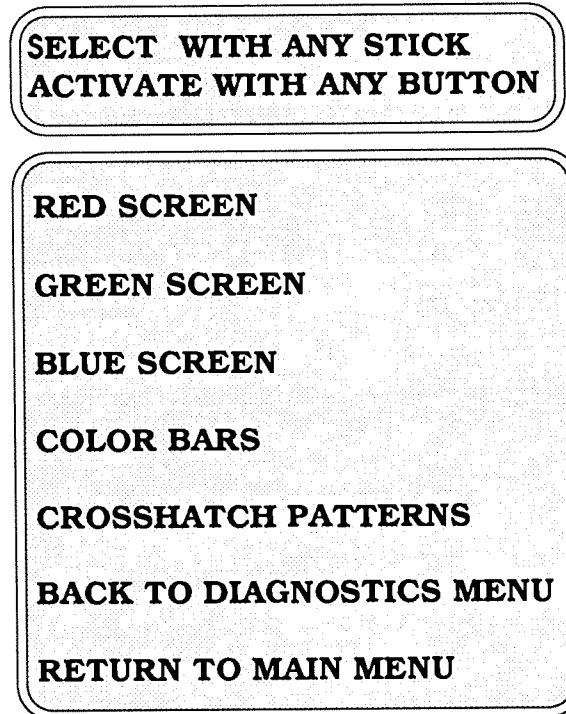

**Monitor Pattern Menu**

The **RED**, **GREEN**, and **BLUE SCREEN** tests fill the screen with either red, green or blue.

The **COLOR BARS** test fills the screen with several shades of colors to help with red, green and, blue level adjustments. Each color should appear sharp and clear.

The **CROSSHATCH PATTERNS** test fills the screen with a grid and a series of dots. The grid and the dots should be clear. The dots should appear round.

If any of the Monitor Pattern Tests shows a need for adjustment, use the proper white knobs on the Monitor Board.

Use any joystick to select **RETURN TO MAIN MENU** or **BACK TO DIAGNOASTIC MENU** and activate with any control panel button.

### **Burn-in Test**

The Burn-in Test continually repeats the CPU Board Test. Move any joystick to select the Burn-in Test; then, press any control panel button to activate the test. When the Burn-in Test detects an error, the test stops and displays an error message on the screen. The second page of the Audit Table specifies the number of Burn-in cycles successfully completed. Use this test to find intermittent CPU problems.

To exit this test, switch the game Off then On again.

## COIN BOOKKEEPING

To enter the Coin Bookkeeping from the Main Menu, move any joystick to select the Coin Bookkeeping option; then, press any control panel button to activate it.

The Coin Bookkeeping Table records the coinbox totals and game play counters. The left side of the table names the bookkeeping item; the right side shows the number of coins, credits, or plays for each item.

To exit Coin Bookkeeping, move any joystick to select RETURN TO MAIN MENU; then, press any control panel button to activate it.

LEFT SLOT COINS	0
RIGHT SLOT COINS	0
THIRD SLOT COINS	0
FOURTH SLOT COINS	0
SERVICE CREDITS	0
PAID CREDITS	0
TOTAL PLAYS	0
PLAYS UNTIL HIGH SCORE RESET	5000

**MORE DETAILED DATA**

---

**RETURN TO MAIN MENU**

**Coin Bookkeeping Table**

LEFT SLOT COINS	0
RIGHT SLOT COINS	0
THIRD SLOT COINS	0
FOURTH SLOT COINS	0
TOTAL COLLECTIONS	0

**CLEAR COIN METERS**

---

**RETURN TO MAIN MENU**

**Total Collection Table**

## GAME AUDITS

To enter Game Audits from the Main Menu, move any joystick to select the Game Audits option; then, press any control panel button to activate it. To advance to the next (or return to the previous) page of the Game Audit Table, move any joystick to select either "Next Audit Page", or "Previous Audit Page"; then, press any control panel button to change the page.

The Game Audits Table records the game play statistics. The left side of the table names the Audit item; the right side shows the amount of play.

<b>TOTAL GAME UPTIME</b>	<b>0</b>
<b>TOTAL PLAY TIME</b>	<b>0</b>
<b>TIME 1 PLAYER ONLY</b>	<b>0</b>
<b>TIME 2 PLAYER SIMULTANEOUS</b>	<b>0</b>
<b>TIME 3 PLAYER SIMULTANEOUS</b>	<b>0</b>
<b>TIME 4 PLAYER SIMULTANEOUS</b>	<b>0</b>
<b>NEXT AUDIT PAGE</b>	
<b>RETURN TO MAIN MENU</b>	

**Page 1 of Audit Table**

<b>TOTAL PLAYS</b>	<b>0</b>
<b>CONTINUES TAKEN</b>	<b>0</b>
<b>GAMES PLAYED TO COMPLETION</b>	<b>0</b>
<b>TRADING CARDS DISPENSED *</b>	<b>0</b>
<b>EASY DIFFICULTY CHOSEN</b>	<b>0</b>
<b>MEDIUM DIFFICULTY CHOSEN</b>	<b>0</b>
<b>HARD DIFFICULTY CHOSEN</b>	<b>0</b>
<b>BURN-IN CYCLES COMPLETED</b>	<b>0</b>
<b>PREVIOUS AUDIT PAGE</b>	
<b>RETURN TO MAIN MENU</b>	

**Page 2 of Audit Table**

To exit the Game Audit Table, move any joystick to select RETURN TO MAIN MENU; then, press any control panel button to activate your selection.

**\* Available in Upright Dedicated Games Only.**



## **GAME ADJUSTMENTS**

Move any joystick to select the Game Adjustment option on the Main Menu; then, press any control panel button to activate it.

The Game Adjustments Menu allows the owner/operator to change the Game Pricing and Game Difficulty.

The Game Adjustments Menu offers several options. Each option has its own menu. Move any joystick to select an option; then, press any control panel button to activate that option. On the next menu screen, move any joystick to select the item you wish to modify; then, press any control panel button to activate that item. The activated item provides a setting choice. Move any joystick to change the current setting value; then, press any control panel button to lock in the new setting value. Moving the joystick up increases the setting value, moving the joystick down decreases the setting value.

To exit the Adjustments Menu, use any joystick to select RETURN TO MAIN MENU; then, use any control panel button to activate your selection.

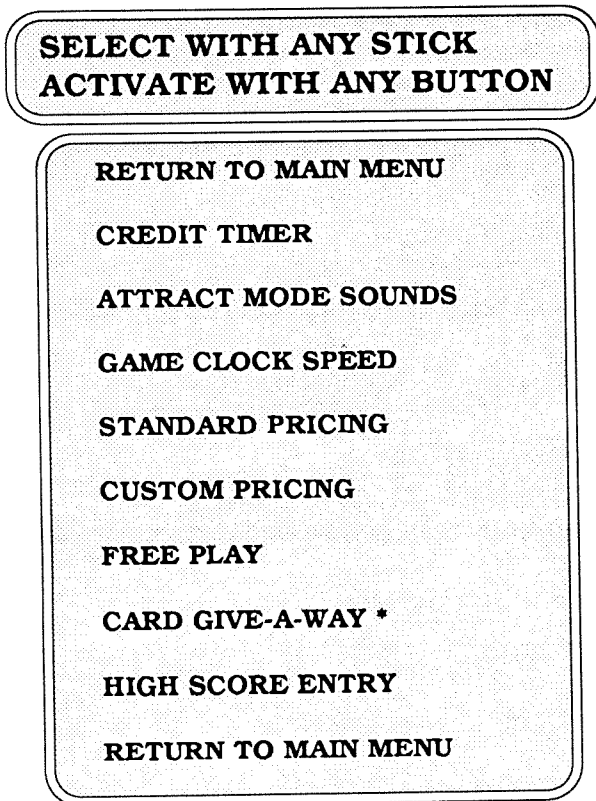

**Game Adjustment Menu**

### **Note**

**Game Adjustments are explained in more detail on the following page.**

**\* Available in Upright Dedicated Games Only.**

**Credit Timer**

Controls the speed of the player credit timer. The settings for the adjustment are:

- Slow
- Medium (factory)
- Fast

**Attract Mode Sounds**

Determines whether the game will make sounds in the attract mode. The settings for the adjustment are:

- Yes (factory)
- No

**Game Clock Speed**

Allows the operator to adjust the speed at which the game clock will countdown. The settings for the adjustment are:

- Slow
- Medium (factory)
- Fast

**Standard Pricing**

Standard Pricing allows the operator to choose any of the "Standard" selections for the Standard Pricing Table.

**Custom Pricing**

Custom Pricing allows the operator to install pricing other than that of the Standard Pricing Table. Custom Pricing also allows the operator to select the maximum amount of credits per game, the amount of credits required to start a game, and the amount or credits required to continue a game. This option is being adjusted from the Dip Switch Settings.

**Free Play**

This option allows the operator to select free play. The settings for the adjustment are:

- No (factory)
- Yes

**High Score Entry**

The operator determines if the players can enter their initials for a High Score. The settings for the adjustment are:

- No
- Yes (factory)

### Standard Pricing Table

NAME	SETTING Credit/Coin	LEFT CHUTE	CENTER CHUTE	RIGHT CHUTE	FOURTH CHUTE
USA 1	1/25¢	25¢		25¢	
USA 2	1/50¢	25¢		25¢	
USA 3	1/50¢, 3/\$1.00	25¢		25¢	
USA 4	1/50¢, 4/\$1.00	25¢		25¢	
USA ECA	1/25¢, 4/\$1.00	\$ 1.00	10¢	25¢	5¢
German 1	1/1 DM, 6/5 DM	1 DM		5 DM	
German 2	1/1 DM, 7/5 DM	1 DM		5 DM	
German 3	1/1 DM, 8/5 DM	1 DM		5 DM	
German 4	1/1 DM, 5/5 DM	1 DM		5 DM	
German ECA	1/1 DM, 2/2 DM, 6/5 DM	5DM	1DM	2DM	
France 1	2/5 F, 5/10 F	5 F		10 F	
France 2	2/5 F, 4/10 F	5 F		10 F	
France 3	1/5 F, 3/10 F	5 F		10 F	
France 4	1/5 F, 2/10 F	5 F		10 F	
France ECA	1/3 X 1 F, 2/5 F, 5/2 X 5 F	1F	10F	5F	
Swiss	1/1 F, 6/5 F	1 F		5 F	
Italy	1/500 Lire	500 Lire		500 Lire	
UK 1	1/20 P, 3/50 P	20 P		50 P	
UK ECA	1/30 P, 2/50 P, 4/£1.00	£1.00	20P	50 P	
Spain 1	1/25 Peseta, 5/100 Peseta	25 Peseta		100 Peseta	10 P
Japan 1	1/100 Yen	100 Yen		100 Yen	

If option desired is not shown above, use custom pricing .

## Custom Pricing

**SELECT WITH ANY STICK  
ACTIVATE WITH ANY BUTTON**

**(1) LEFT CHUTE UNITS**  
**(1) RIGHT CHUTE UNITS**  
**(1) THIRD CHUTE UNITS**  
**(1) FOURTH CHUTE UNITS**  
**(2) UNITS/CREDIT**  
**(3) UNITS/BONUS**  
**(4) MINIMUM UNITS REQUIRED**  
**(5) CREDITS TO START**  
**(6) CREDITS TO CONTINUE**  
**(7) COINS PER DOLLAR**  
**MAXIMUM CREDITS**  
**RETURN TO ADJ. MENU**

- (1) Coins inserted accumulate units. This adjustment specifies the number of units given for each coin in the fourth chute (see "units/credit").
- (2) This is the number of coin units required to buy one credit.
- (3) One bonus credit is awarded after this many coin units have accumulated.
- (4) No credits will be awarded until this many coin units have accumulated.
- (5) Each player needs this many credits to begin a game.
- (6) Each player needs this many credits to continue a game.
- (7) The detailed bookkeeping screen shows total collections based on this many coins per dollar. (Set to zero to disable the display of money totals)
- (8) This is the limit for the credits counter. Additional coins inserted will be lost. (factory setting: 30)

## UTILITIES

Move any joystick to select the Utilities option on the Main Menu; then, press any control panel button to activate it.

The Utilities Menu allows the owner/operator to clear the game's bookkeeping memory and to install a custom message.

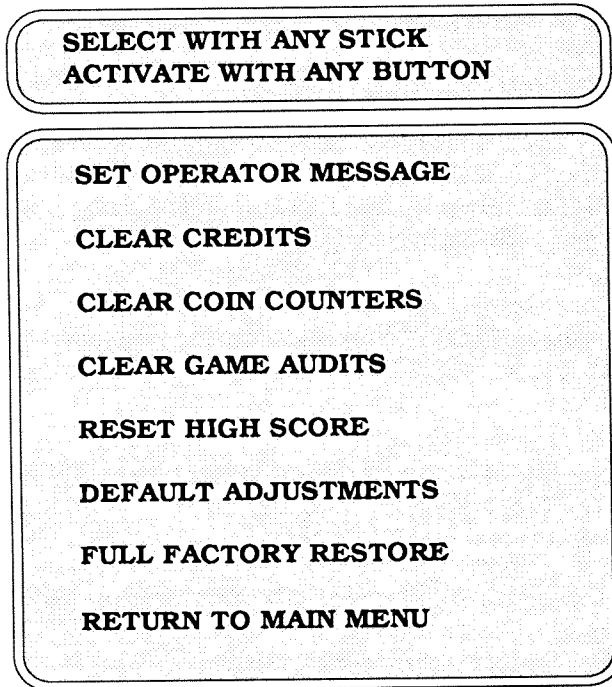

**Utilities Menu**

Move any joystick to select an item from the Utilities Menu; then, press any control panel button to activate that item. After an item has been activated, you are given the option of resetting that item or not. For example,

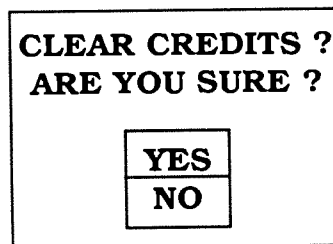

Move any joystick to choose YES or NO; then, press any control panel button to lock in your choice and to return to the Utilities Menu.

To exit the Utilities Menu, move any joystick to select RETURN TO MAIN MENU; then press any control panel button to activate your selection.

---

---

## Troubleshooting

### Problem

### Possible Solution

No picture or distorted picture.	Check for faulty CPU Board or monitor. Check for disconnected video signal cable.
Turn game On and nothing happens.	Check line fuse. Check for +5vdc at pins C, D, 3 and 4 of the JAMMA Connector.
No sound.	Check the speaker and speaker connection to pins L and 10 on the JAMMA Connector. Check the volume control setting. Check for +12vdc at pins F and 6 on the JAMMA Connector. Check interboard wiring from CPU Board to Sound Board. Be sure the red line on the ribbon cable goes to pin 1 on both boards.
Move the joystick and the player doesn't move.	Check for open wires between the joystick and the CPU Board. Check for contamination on the joystick switch contacts and the CPU Board pins. Check for proper ground.
Move the joystick and the player moves in the wrong direction.	A joystick switch is wired wrong. Check the JAMMA Chart, the Control Panel Wire List, or the Cabinet Wiring Diagram.
Press the Start or Action Buttons and nothing happens.	Check for open wires between the pushbutton switch and CPU Board. Check for contamination on the CPU Board pins or the pushbutton switch contacts. Check for proper ground. Be sure pushbutton switches are wired correctly.
No credit is given when coins are inserted.	Check DIP Switch coin setting. Check for contamination on the coin switch contacts. Check for an open wire between coin switch 1 and pin 16 on the JAMMA Connector or coin switch 2 and pin T of the JAMMA connector.
To many credits are given for the number of coins inserted.	Check the price per game setting. Check for a short between pins T and 16 on the JAMMA Connector.
Game stays in the Test Mode.	Check that Switch #8 on DIP Switch #2 is Off. If you have installed an optional Test Switch be sure it is set to Off. Be sure the DIP Switch and optional Test Switch are not shorted to ground. You can use the DIP Switch Test to prove this. If the switch shows as closed during the DIP Switch Test but is set in the open position, then the switch is somehow shorted to ground.

# **SUPER HIGH IMPACT FOOTBALL KIT**

**S E C T I O N  
two**

---

PC Board Parts

# A-13234-40017 CPU Board Assembly

INDICATES  
KEEPIING PIN

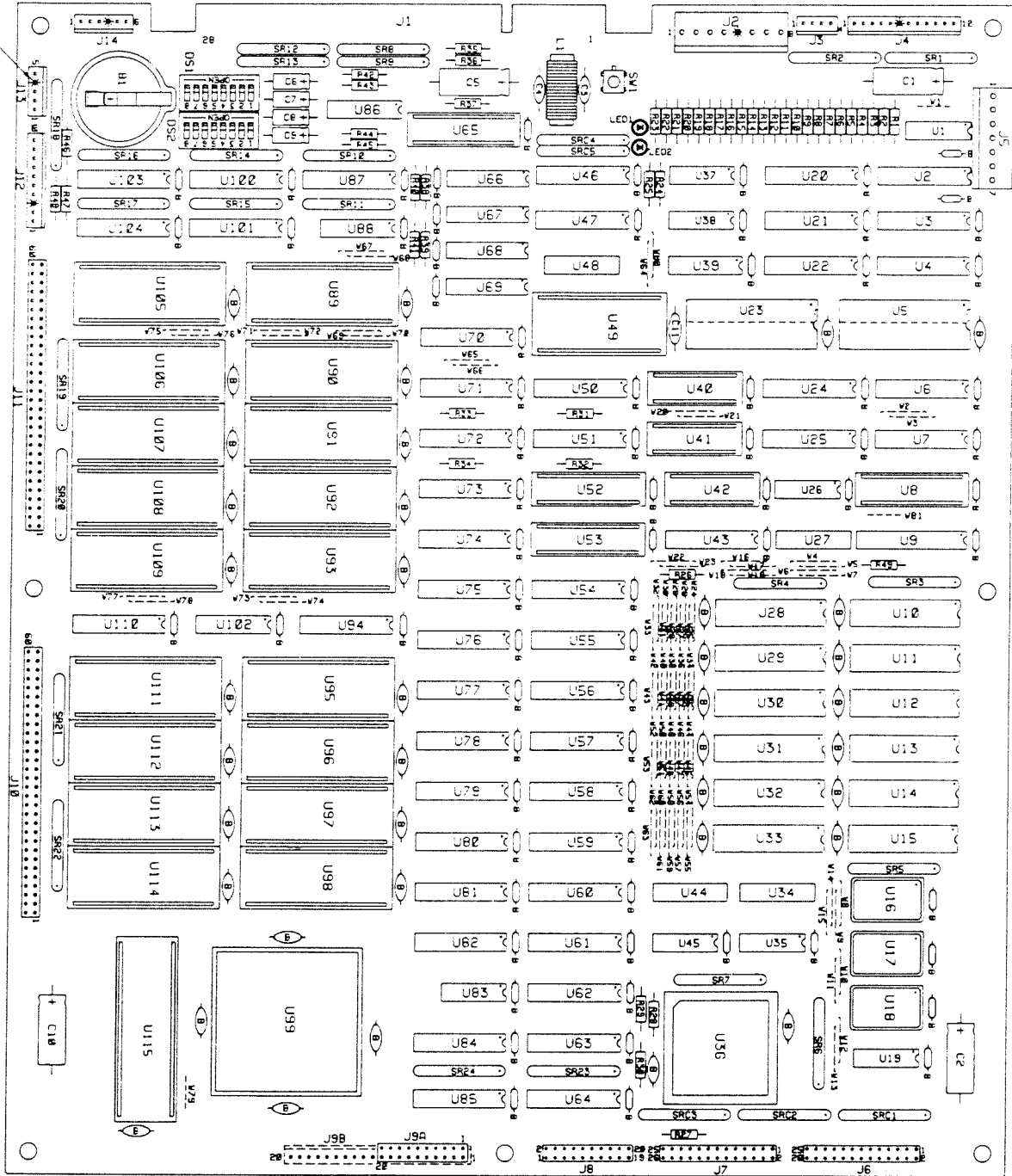



## A-13234-40017 CPU Board Parts

Part No.	Ckt.Designator	Description	Part No.	Ckt.Designator	Description
5770-12555-00		Bare PC Brd.	5043-08980-00	B	Cap. .01 µfd 10V
5281-09737-00	U1	IC, 74LS 86	5040-08986-00	C1, C2, C5, C10	Cap. 100µfd 10V
5317-12211-00	U2, U20, U24, U43		5043-09845-00	C3, C4	Cap. .001µfd 10V
	U61, U62, U70	IC, 74ALS541	5041-09243-00	C6-C9	Cap. 10µfd 10V
5317-12212-00	U3, U6, U7, U21, U25	74ALS574	5043-8996-00	C11	Cap. .1µfd
	U50, U58, U63, U64		5019-12611-00	SR1, SR2, SR8	SIP, 470Ω 5 Res.
	U71, U72, U74, U79, U84, U85			SR9, SR12, SR13	
5317-12208-00	U4, U22, U54-U57	74ALS245	5019-09362-00	SR18	
	U59, U60, U75-U78			SR3, SR4, SR6 SIP, 4.7KΩ	
	U80, U81, U94, U110			SR7, SR11, SR15	
5340-12840-00	U5, U23	IC, 8K x 8 S RAM		SR17, SR19-SR24	
5700-12047-00	U8, U52, U53, U65	24 pin Socket	5019-10143-00	SRC1-SRC3	
5340-12213-00	U10, U11, U28-U33	IC, 4461 VRAM	5060-10396-00	SR5	SIP, 470Ω 9 Res.
5521-10421-00	U16	48 MHZ Xtal		SRC4, SRC5	SIP. 4.7KΩ 470pf
5521-10318-00	U17	24 MHZ Xtal		SRC10, SRC14	
5283-10468-00	U19, U45	IC, 74F74		SRC16	
5019-10849-00	U27, U34, U44, U48	100Ω DIP Res.	5671-09019-00	LED1, LED 2	LED, Red
5317-12305-00	U35	IC, 74ALS00	5551-09822-00	L1	Inductor, 4.7UH
5700-12253-00	U36	68 pin Socket	5645-09025-00	DS1, DS2	DIP. Sw. 16 pin
5280-09309-00	U37	IC, 7407	5641-12551-00	SW1	Pushbutton Sw.
5281-09487-00	U38	IC, 74LS74	5881-12315-00	B1	Battery Holder
5434-12255-00	U39	IC, MAX691	5791-10862-08	J2	8 pin Connector
5700-09915-00	U40-U42	20 pin Socket	5791-12461-12	J4	12 pin Connector
5311-12287-00	U47, U46, U87, U100	IC, 74HC541	5791-10850-00	J6, J7	26 pin Ribbon Connector
	U101, U103, U104			J8	20 pin Ribbon Connector
5700-10176-00	U49	28 pin Socket	5791-09437-00	J8	20 pin Ribbon Connector
5311-12285-00	U51, U73, U82	IC, 74HC573		J12	10 pin Connector
5340-12014-00	U66-U69	IC, 4464 DRAM	5791-12461-10	U12-U15	24 pin Socket
5283-10552-00	U83	IC, 74F04	5700-12252-00	J13	50 pin Connector
5370-12602-00	U86	IC, ULN2064B	5719-12461-05		CPU Sub-assembly
5317-12023-00	U88	IC, 74ALS138	C-13235-2	U8	IC, PLD Color RAM
5700-12088-00	U89-U93, U95-U98	32 pin Socket	A-5346-40017-1	U36	IC, TMS34010-50
	U105-U109, U111-U114		5400-12220-00	U40	IC, PLD Address Decoder
5700-12254-00	U99	144 pin Socket	A-5346-40017-2	U41	IC, PLD Video RAM
5317-12024-00	U102	IC, 74ALS139	A-5346-40017-3	U42	IC, PLD Local Control
5700-08985-00	U115	40 pin Socket	A-5346-40017-9	U49	IC 8Kx8 Static RAM 100ns
5010-08991-00	R1, R24, R27	Res. 4.7KΩ 5% 1/4W	5340-12558-00	U52	IC, PLD Video RAM Sequ.
5010-10204-00	R2, R7, R12	Res. 1KΩ 2% 1/4W	See Note *	U53	IC, PLD Image ROM
5010-10205-00	R3, R8, R13	Res. 2KΩ 2% 1/4W	See Note *	U65	IC, PLD Miscellaneous
5010-10000-00	R4, R9, R14	Res. 3.9KΩ 5% 1/4W	A-5346-40017-7	U115	IC, PLD Autoerase
5010-09219-00	R5, R10, R15	Res. 8.2KΩ 5% 1/4W	A-5343-40017-8	U89	IC, Game EPROM
5010-08772-00	R6, R11, R16	Res. 15KΩ 5% 1/4W	A-5343-40017-1	U95	IC, Game EPROM
5010-09001-00	R23, R25	Res. 330Ω 5% 1/4W	A-5343-40017-6	U96	IC, Game EPROM
5010-09036-00	R26, R29-R34, R50, R51	Res. 100Ω 5% 1/4W	A-5343-40017-7	U97	IC, Game EPROM
	R35-R37, R46-R48	Res. 470Ω 5% 1/4W	A-5343-40017-8	U98	IC, Game EPROM
5010-09416-00	R38-R45	Res. 2.7Ω 5% 1/4W	5410-12239-00	U99	IC, Custom ASIC
5010-08997-00	W2, W8, W11, W12, W14, W21, W22, W24, W27, W29, W31, W32, W34, W36, W39, W41, W42, W45, W47, W48, W50, W52, W55, W57, W58, W60, W62, W66, W68, W69, W71, W73, W75, W77, W80	Res. 0Ω	A-5343-40017-10	U105	IC, Game EPROM
			A-5343-40017-11	U106	IC, Game EPROM
			A-5343-40017-12	U107	IC, Game EPROM
			A-5343-40017-13	U108	IC, Game EPROM
			A-5343-40017-14	U109	IC, Game EPROM
			A-5343-40017-15	U111	IC, Game EPROM
			A-5343-40017-16	U112	IC, Game EPROM
			A-5343-40017-17	U113	IC, Game EPROM
			A-5343-40017-18	U114	IC, Game EPROM
			5880-11056-00	B1	Battery, Lithium 3V

Note \*

For Rev-A, CPU Boards Order  
A-5346-40017-11 for U52  
A-5346-40017-12 for U53

For Rev-B, CPU Boards Order  
A-5346-40017-10 for U52  
A-5346-40017-6 for U53

# A-13971-40017 Sound Board Assembly

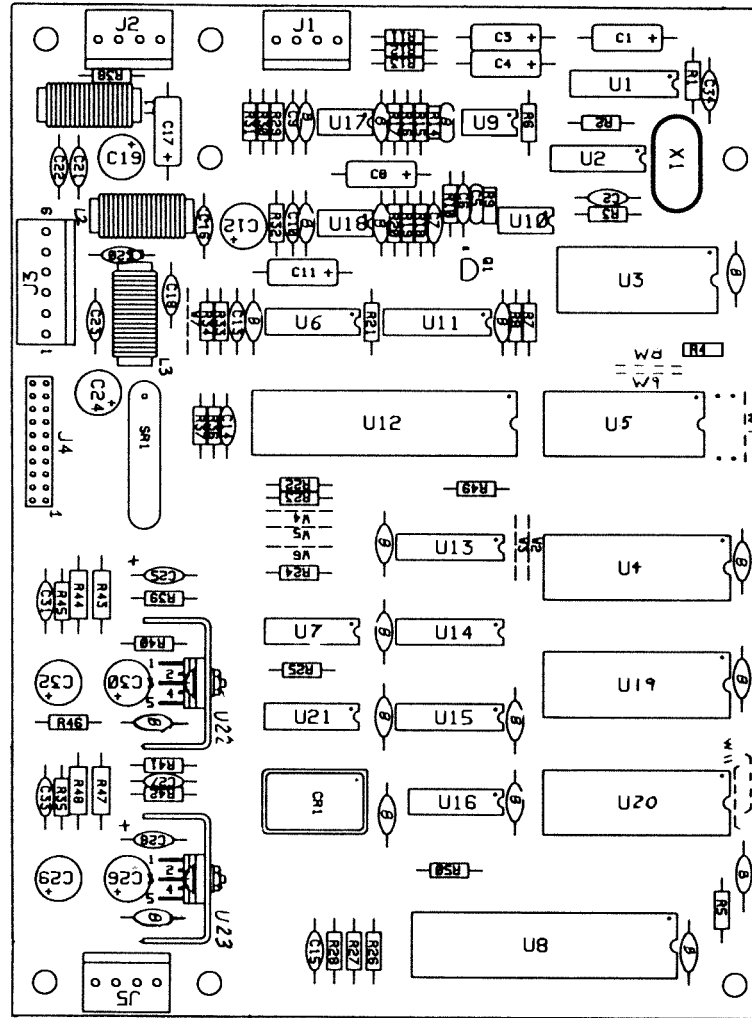

## A-13971-40017 Sound Board Parts

Item	Part Number	Designation	Description
1	20-9229		Thermal Compound
2	4006-01113-06		#6-32 x 3/8 P-PH-S
3	4406-01128-00		#6-32 Hex Nut
4			
5	5010-08772-00	R18	RES. 15K 1/4 W 5%
6	5010-08824-00	R32	RES. 43K 1/4 W 5%
7	5010-08846-00	R31	RES. 220K 1/4 W 5%
8	5010-08983-00	R7, R8, R9	RES. 3.3K 1/4 W 5%
9	5010-08991-00	R1, R4, R5, R11, R12, R25 - R28, R33, R36, R37, R49, R50	RES. 4.7K 1/4 W 5%
10	5010-08998-00	R2, R3	RES. 2.2K 1/4 W 5%
11	5010-09034-00	R17, R22 - R24, R34	RES. 10K 1/4 W 5%
12			
13	5010-09161-00	R35, R45	RES. 2.2 $\Omega$ 1/4 W 5%
14	5010-09162-00	R39	RES. 100K 1/4 W 5%
15	5010-09179-00	R10	RES. 3.3M 1/4 W 5%
16	5010-09181-00	R44, R48	RES. 1 $\Omega$ 1/2 W 5%
17	5010-09219-00	R38	RES. 8.2K 1/4 W 5%
18	5010-09324-00	R6, R19, R20, R21	RES. 27K 1/4 W 5%
19	5010-09331-00	R16	RES. 13K 1/4 W 5%
20	5010-09333-00	R29	RES. 180K 1/4 W 5%
21	5010-09342-00	R30	RES. 36K 1/4 W 5%
22	5010-09358-00	R41, R42	RES. 1K 1/4 W 5%
23	5010-09361-00	R43, R46, R47	RES. 220 $\Omega$ 1/2 W 5%
24	5010-10258-00	R40	RES. 1M 1/4 W 5%
25	5010-10985-00	R14, R15	RES. 20K 1/4 W 5%
26	5013-09427-00	R13	RES. 4.99K 1/4 W 5%
27	5040-09343-00	C1, C3, C4, C8, C17	CAP. 10M 20V +/- 20%
28	5040-09365-00	C11	CAP. 1M 63V +50% -10%
29	5040-09776-00	C26, C30	CAP. 470M 16V +50% -10%
30	5040-10974-00	C12, C19, C24	CAP. 100M 35V
31	5040-12006-00	C29, C32	CAP. 1000M 16V 20% RD.
32	5041-09243-00	C25, C28	CAP. 10M 10V +/-10%
33	5043-08980-00	C5, B(17)	CAP. .01M 50V +80% -20%
34	5043-08996-00	C31, C33	CAP. 1M 50V +/-20%
35	5043-09065-00	C13, C14, C15	CAP. 470P 50V +/-20%
36	5043-09492-00	C2, C34	CAP. 100P 50V +/-20%
37	5043-09844-00	C6	CAP. 47P 50V +/-20% AX
38	5043-09845-00	C16, C18, C20 - C23, C27	CAP. 1KP 50V +/-20% AX
39	5046-09346-00	C7	CAP. 1200P 50V +/-5%
40	5046-09350-00	C9	CAP. 180P 100V +/-5%
41	5048-10992-00	C10	CAP. 4700P 50V +/-10%
42	5060-10396-00	SP1	SIP 4.7K 470P 8RBC
43	5160-10269-00	Q1	TRANS 2N3904 NPN
44	5281-09215-00	U2	IC 74LS04 HEX INV
45	5281-09235-00	U21	IC 74LS10 TRPL NAN
46	5281-09246-00	U14	IC 74LS139 2-4 DEC
47	5281-09487-00	U7, U16	IC 74LS74 DUAL D F/F
48	5281-09745-00	U15	IC 74LS138 DMLTPX
49	5281-10043-00	U13	IC 74LS175
50	5340-10139-00	U5	RAM/S 5516-2 2KX8
51	5370-09156-00	U22, U23	IC 2002 AUD AMP
52	5370-09321-00	U9, U10, U17, U18	IC 1458 OP - AMP
53	5370-09691-00	U6	IC 55536-9 CVSD
54	5371-09152-00	U11	IC 1408 D/A CONV
55	5430-10322-00	U12	IC 68B21 PIA 2MHz
56	5520-09020-00	X1	Crystal 3.58MHz
57	5521-10931-00	CR1	OSC 8 MHz
58	5551-09822-00	L1, L2, L3	IND 4.7 UH 3A
59	5700-08985-00	U8	Socket IC 40 Pin
60	5700-09004-00	U3	Socket IC 24 Pin
61	5700-09006-00	U1	Socket IC 16 Pin
62	5700-12088-00	U4, U19, U20	Socket IC 32 Pin
63	5705-09199-00		Heat Sink #6030B
64	5766-12702-00		PCB Audio System
65	5791-09437-00	J4	20 HCN 2x10 ST
66	5791-10862-04	J1, J2, J5	4H STR SQ. Pin .156
67	5791-10862-06	J3	6H STR SQ. Pin .156

## Notes

# **SUPER HIGH IMPACT FOOTBALL KIT**

**S E C T I O N  
three**

---

Schematics and Diagrams

**This page intentionally left blank.**

# Coin Switch and Meter Wiring

## Option 1

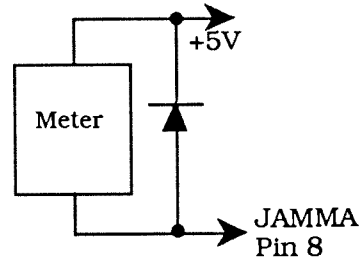
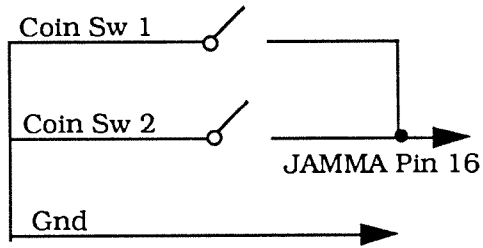

## Option 2

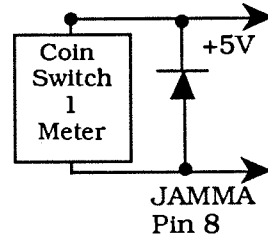
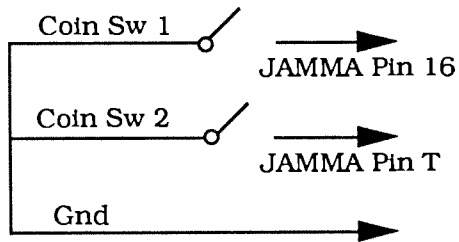

## Wrong Way !

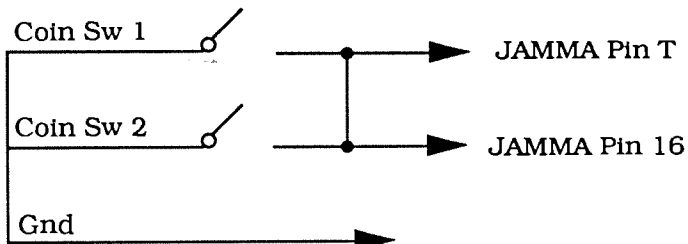

**Do NOT Connect the coin switches this way. This Circuit is INCORRECT and will cause twice as many credits per coin.**

## JAMMA Chart

Function	Wire Color	Pin	Pin	Wire Color	Function
Ground	Blk	1	A	Blk	Ground
Ground	Blk	2	B	Blk	Ground
+5 Volts DC	Gry	3	C	Gry	+5 Volts DC
+5 Volts DC	Gry	4	D	Gry	+5 Volts DC
-5 Volts DC	Gry-Grn	5	E	Gry-Grn	-5 Volts DC
+12 Volts DC	Gry-Yel	6	F	Gry-Yel	+12 Volts DC
	Key	7	H	Key	
Counter 1 *	Wht-Orn	8	J	Wht-Grn	Counter 2 *
	NC	9	K	NC	
Speaker (+)	Red-Vio	10	L	Grn-Vio	Speaker (-)
	NC	11	M	NC	
Video Red	Red	12	N	Grn	Video Grn
Video Blue	Brn	13	P	Wht	Video Sync
Video Grd	Shield	14	R	Wht-Red	Service Credit *
Test *	Grn	15	S	Wht-Vio	Slam Tilt *
1 Coin	Wht-Blu	16	T	Yel-Wht	2 Coin
1 Start	Yel-Grn	17	U	Yel-Blu	2 Start
1 Up	Org-Blk	18	V	Yel-Blk	2 Up
1 Down	Org-Brn	19	W	Yel-Brn	2 Down
1 Left	Org-Red	20	X	Yel-Red	2 Left
1 Right	Org	21	Y	Yel-Org	2 Right
1 Action	Org-Yel	22	Z	Yel-Vio	2 Action
NC	Org-Grn	23	a	Yel-Gry	NC
NC	Org-Blu	24	b	Vio-Blk	NC
NC	Org-Vio	25	c	Vio-Brn	NC
NC	Org-Gry	26	d	Vio-Red	NC
Ground	NC	27	e	NC	Ground
Ground	Blk	28	f	Blk	Ground

\* Optional function- Game will operate without these.



# Cabinet Wiring Diagram

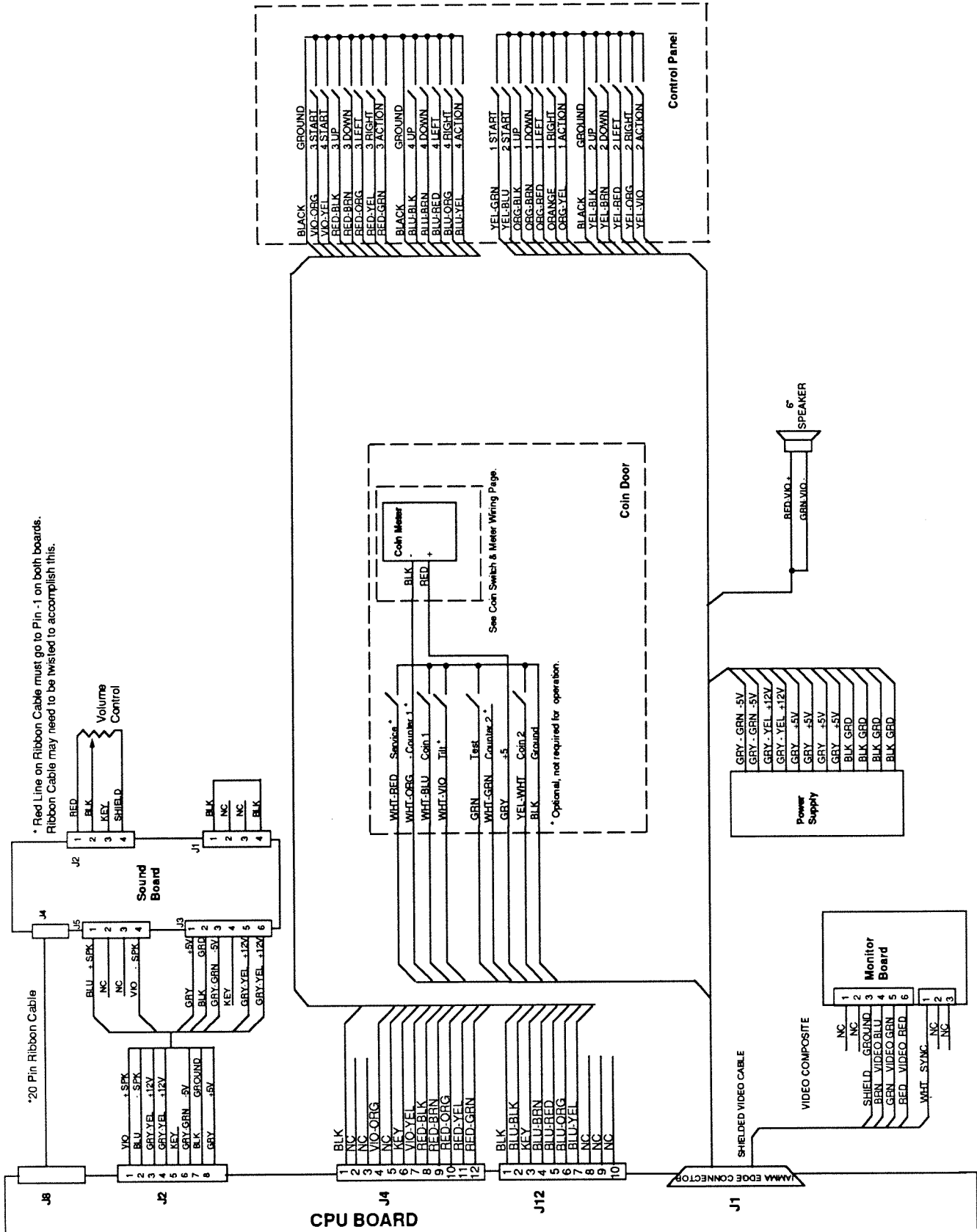

## Control Panel Wire Colors List

### PLAYER ONE

Start	Yellow-Green
Up	Orange-Black
Down	Orange-Brown
Left	Orange-Red
Right	Orange
Action	Orange-Yellow
Ground	Black

### PLAYER TWO

Start	Yellow-Blue
Up	Yellow-Black
Down	Yellow-Brown
Left	Yellow-Red
Right	Yellow-Orange
Action	Yellow-Violet
Ground	Black

### PLAYER THREE

Start	Violet-Orange
Up	Red-Black
Down	Red-Brown
Left	Red-Orange
Right	Red-Yellow
Action	Red-Green
Ground	Black

### PLAYER FOUR

Start	Violet-Yellow
Up	Blue-Black
Down	Blue-Brown
Left	Blue-Red
Right	Blue-Orange
Action	Blue-Yellow
Ground	Black

## **PC Board Jumper List**

### **SOUND BOARD**

**W2, W9, W11**

### **CPU BOARD**

**W2, W8, W11, 12, W22, W24, W27, W29,  
W31, W32, W34, W36, W39, W41, W42,  
W45, W47, W48, W50, W52, W55, W57,  
W58, W60, W62, W66, W68, W69, W71,  
W73, W75, W77, W80**

# Interboard Wiring

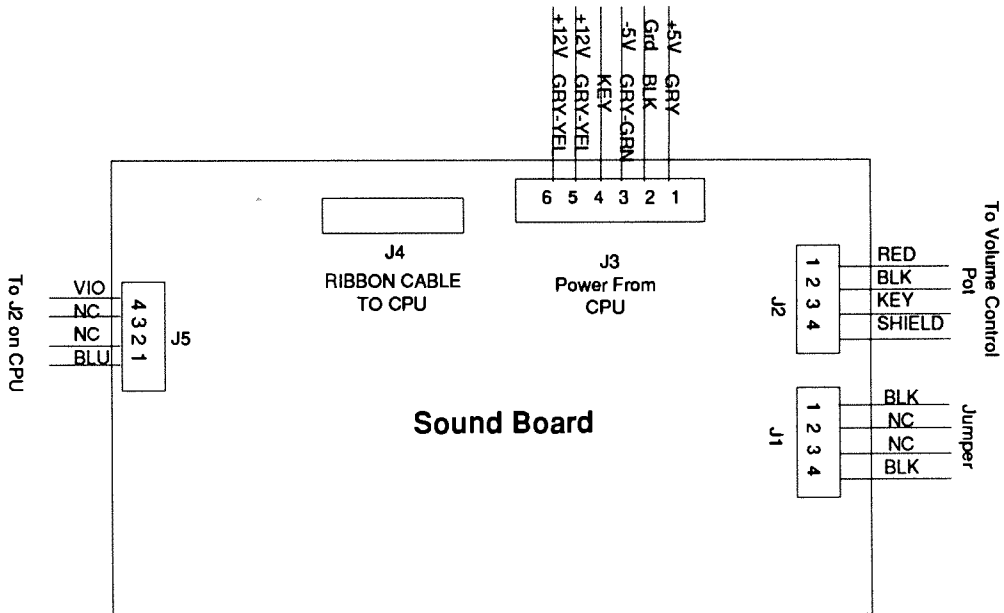
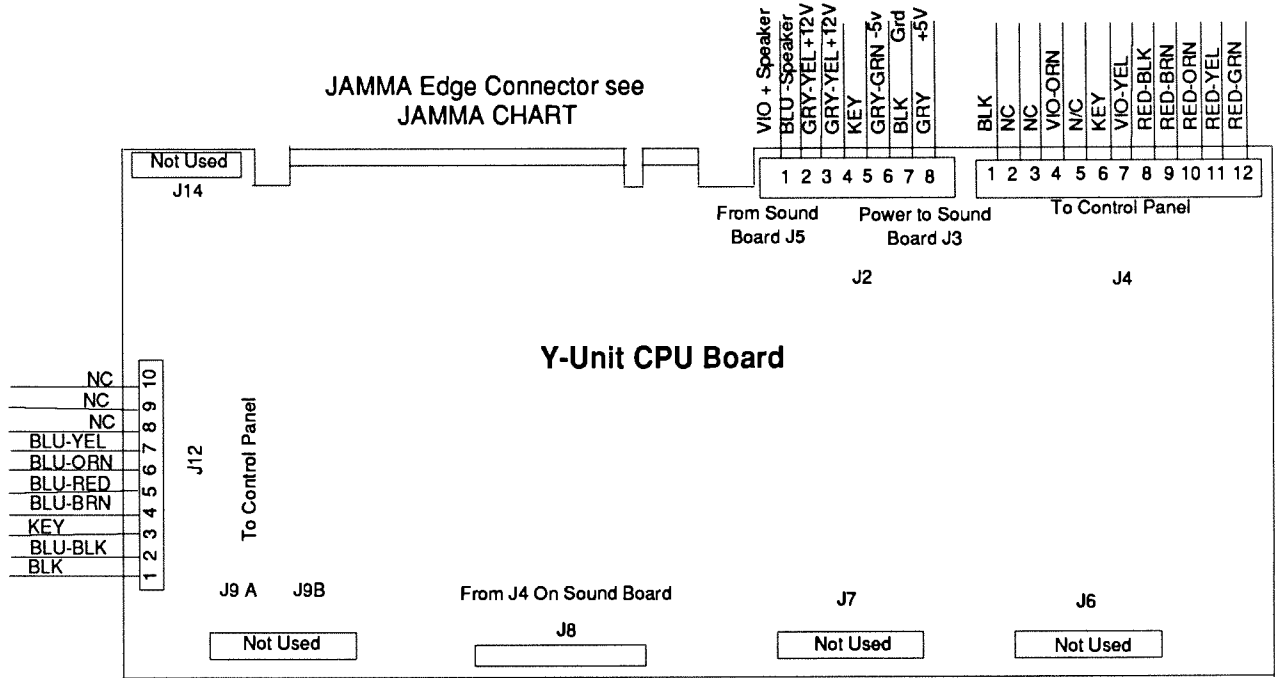



# CPU Sheet 1 of 16

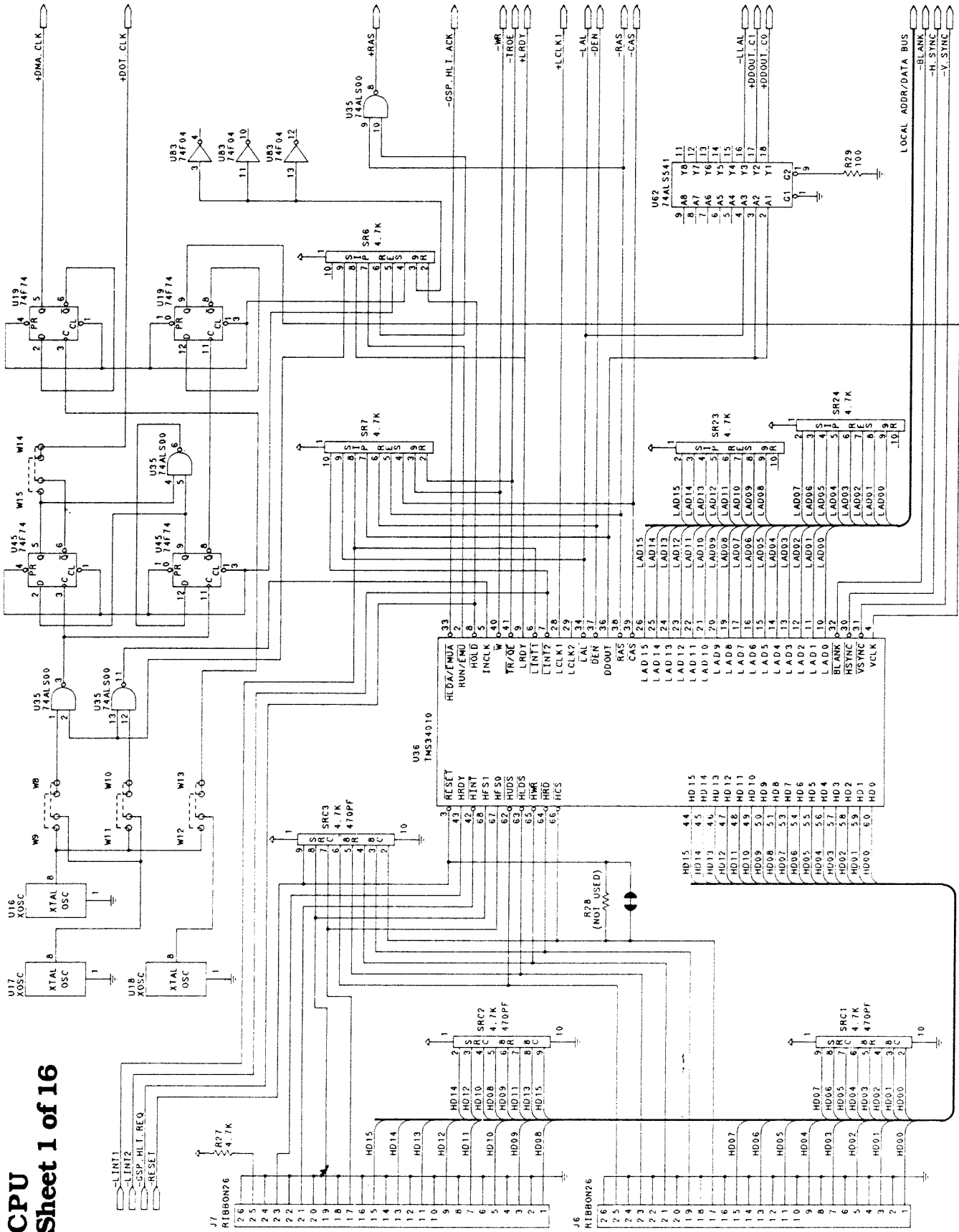

# CPU Sheet 2 of 16

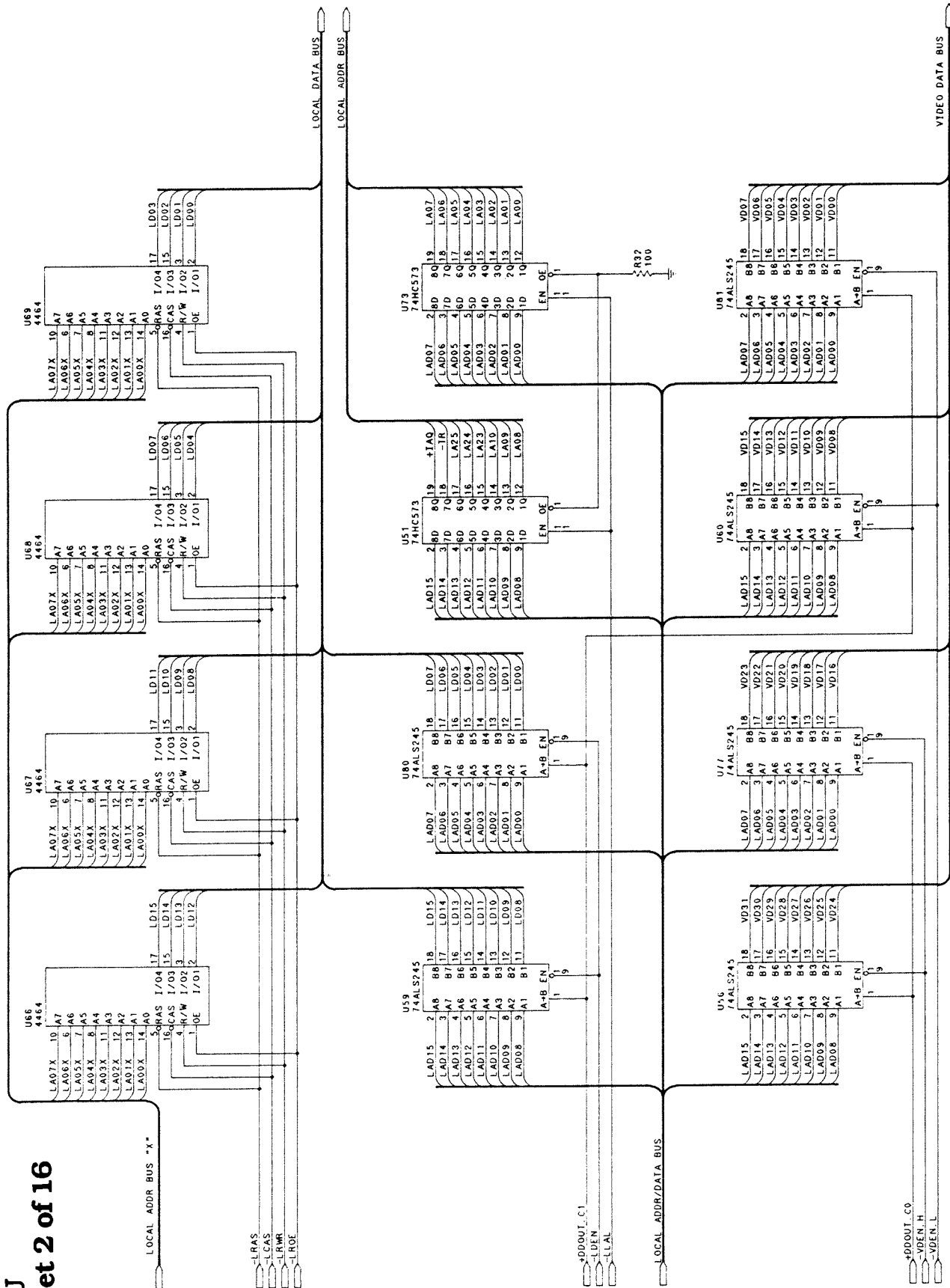







# CPU Sheet 5 of 16

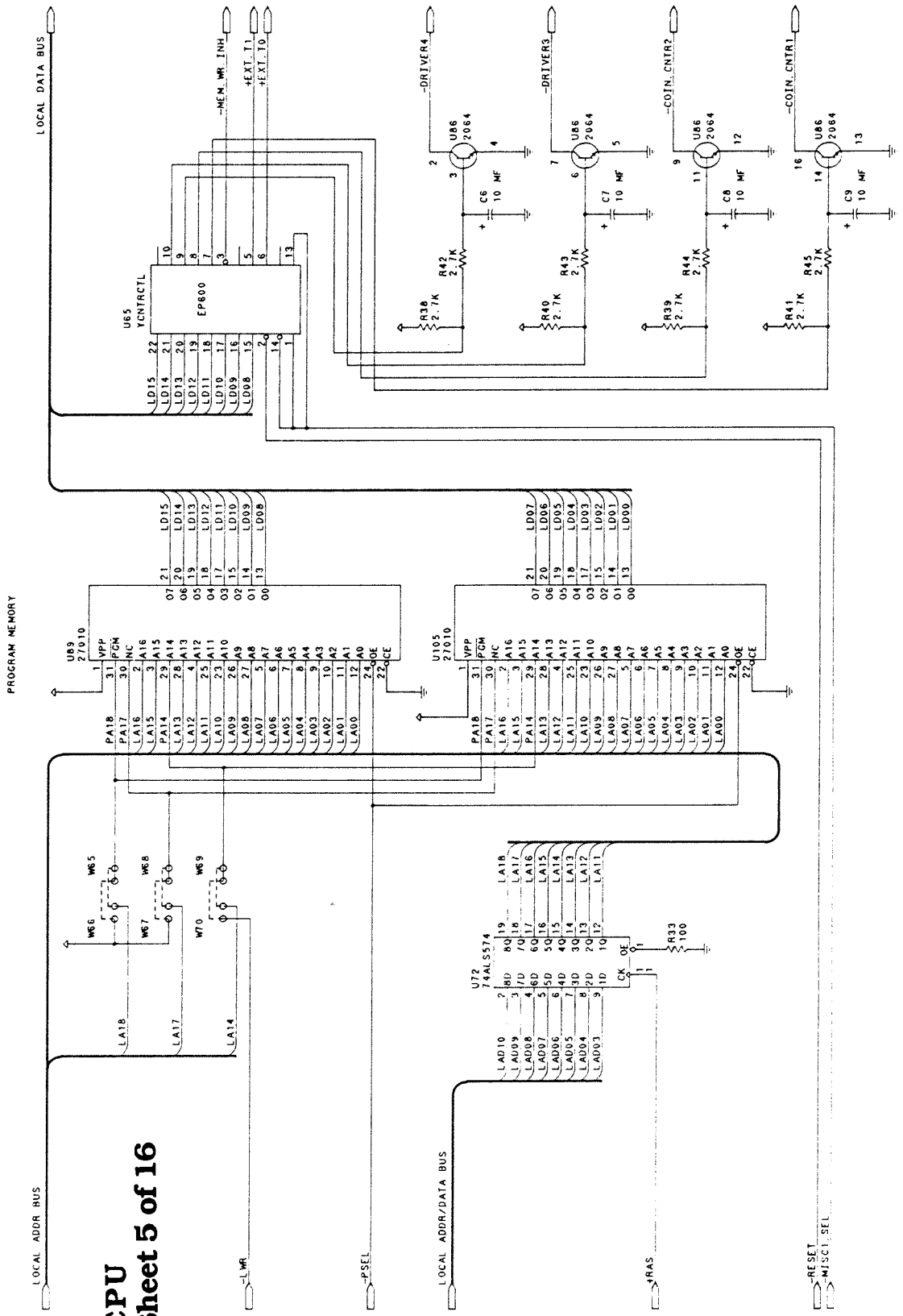

# CPU Sheet 6 of 16

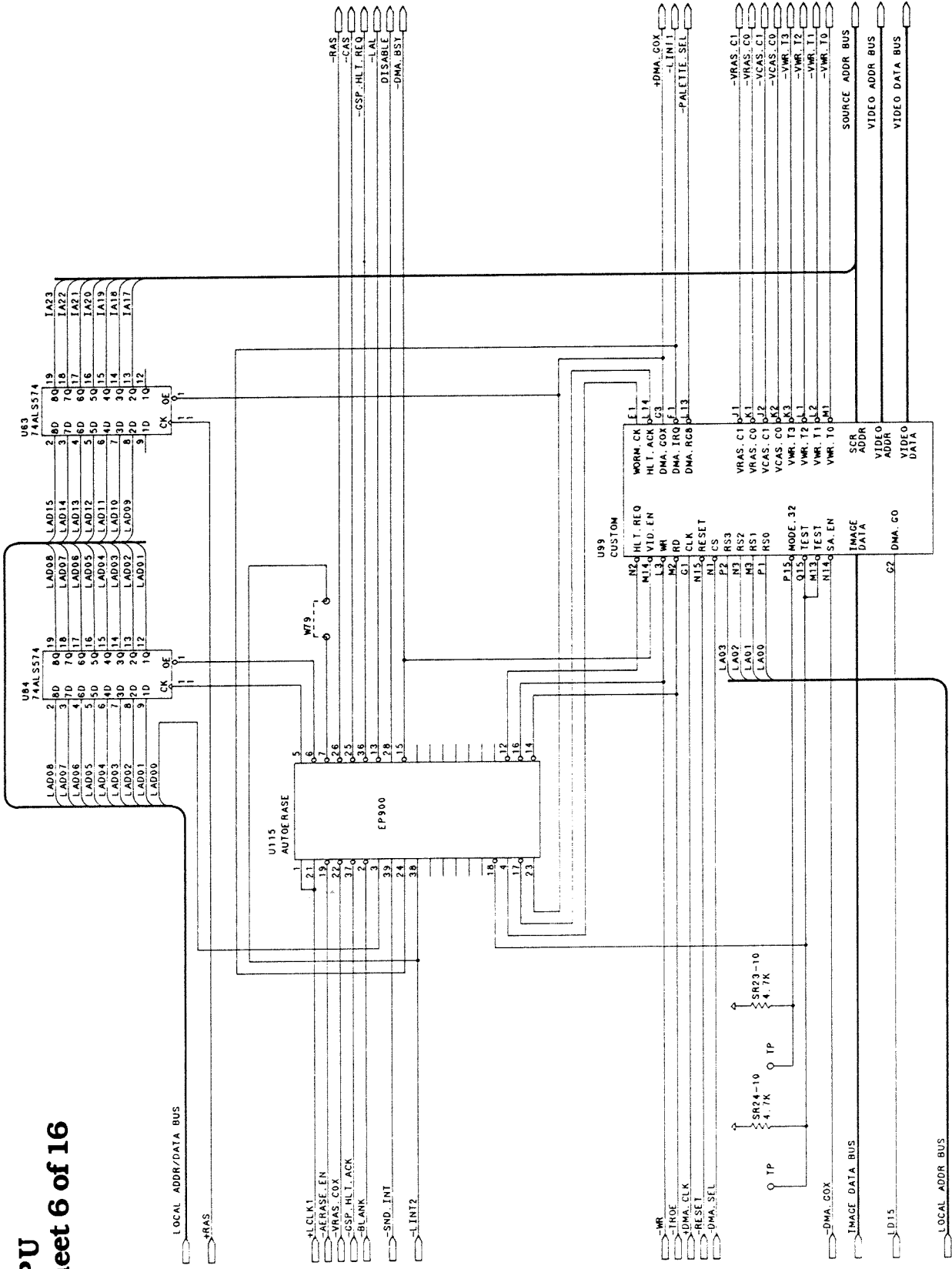

# CPU Sheet 7 of 16

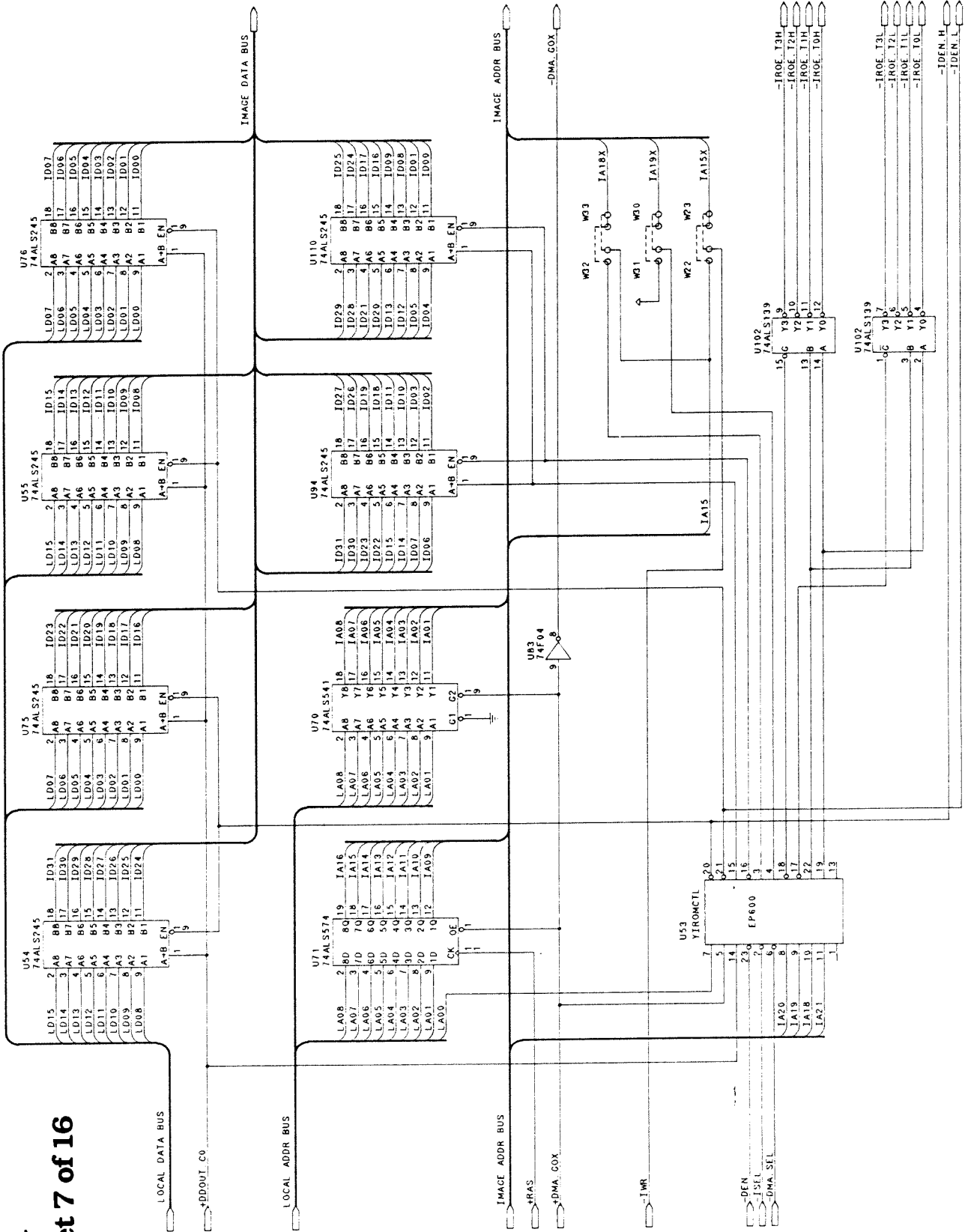

# CPU Sheet 8 of 16

IMAGE MEMORY

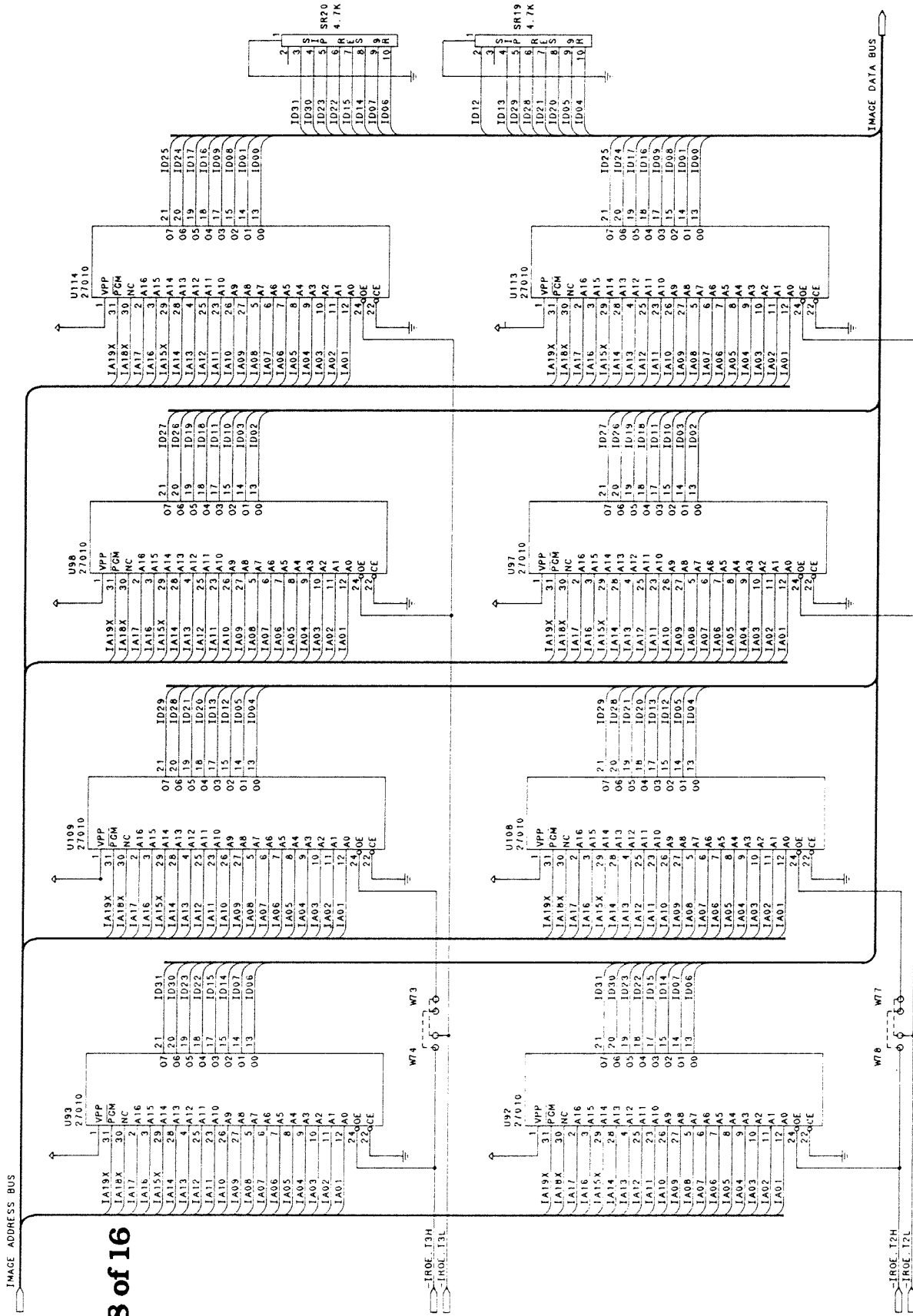

# CPU Sheet 9 of 16

IMAGE MEMORY

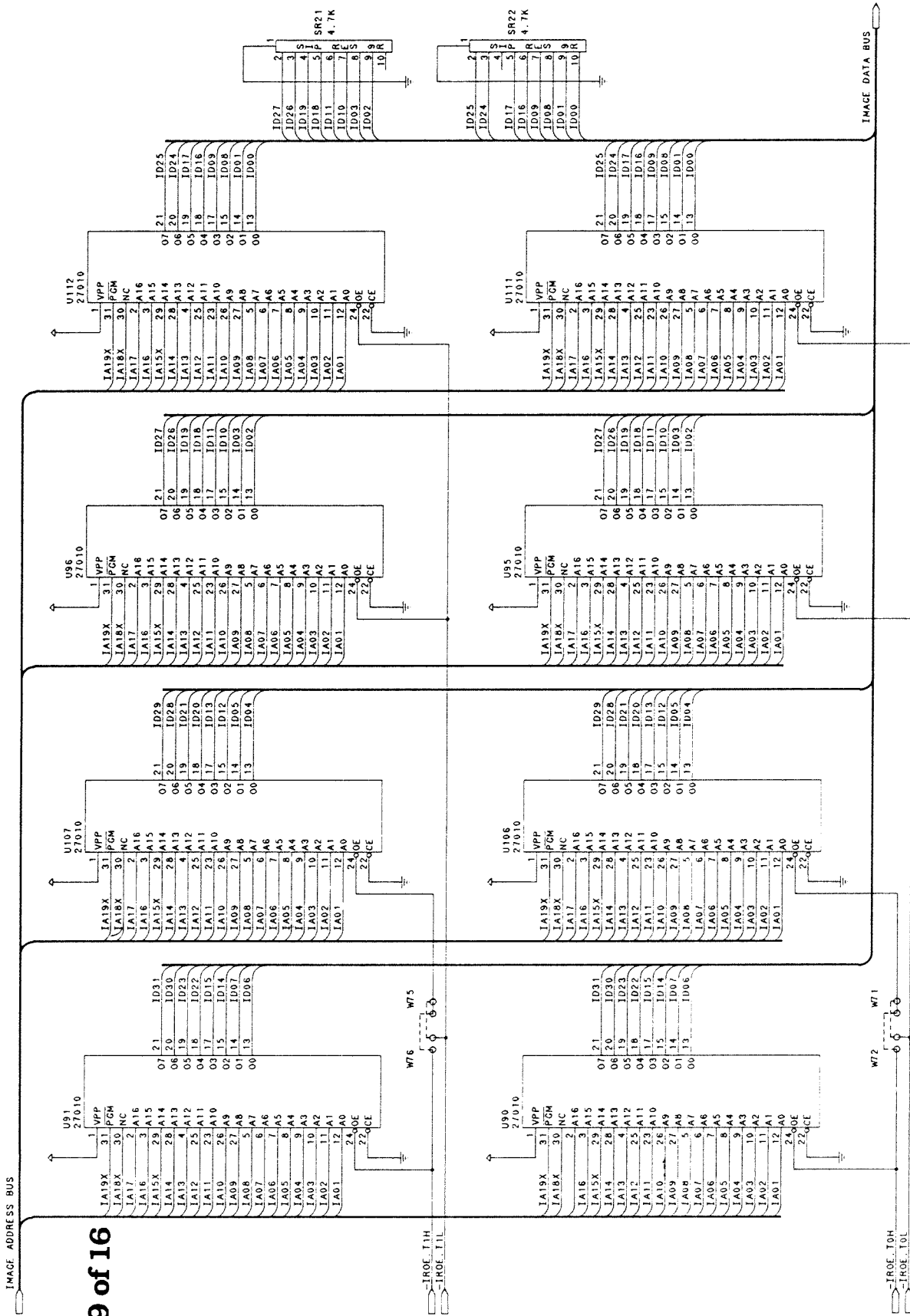

VIDEO ADDR BUS \*X\*

# CPU Sheet 10 of 16

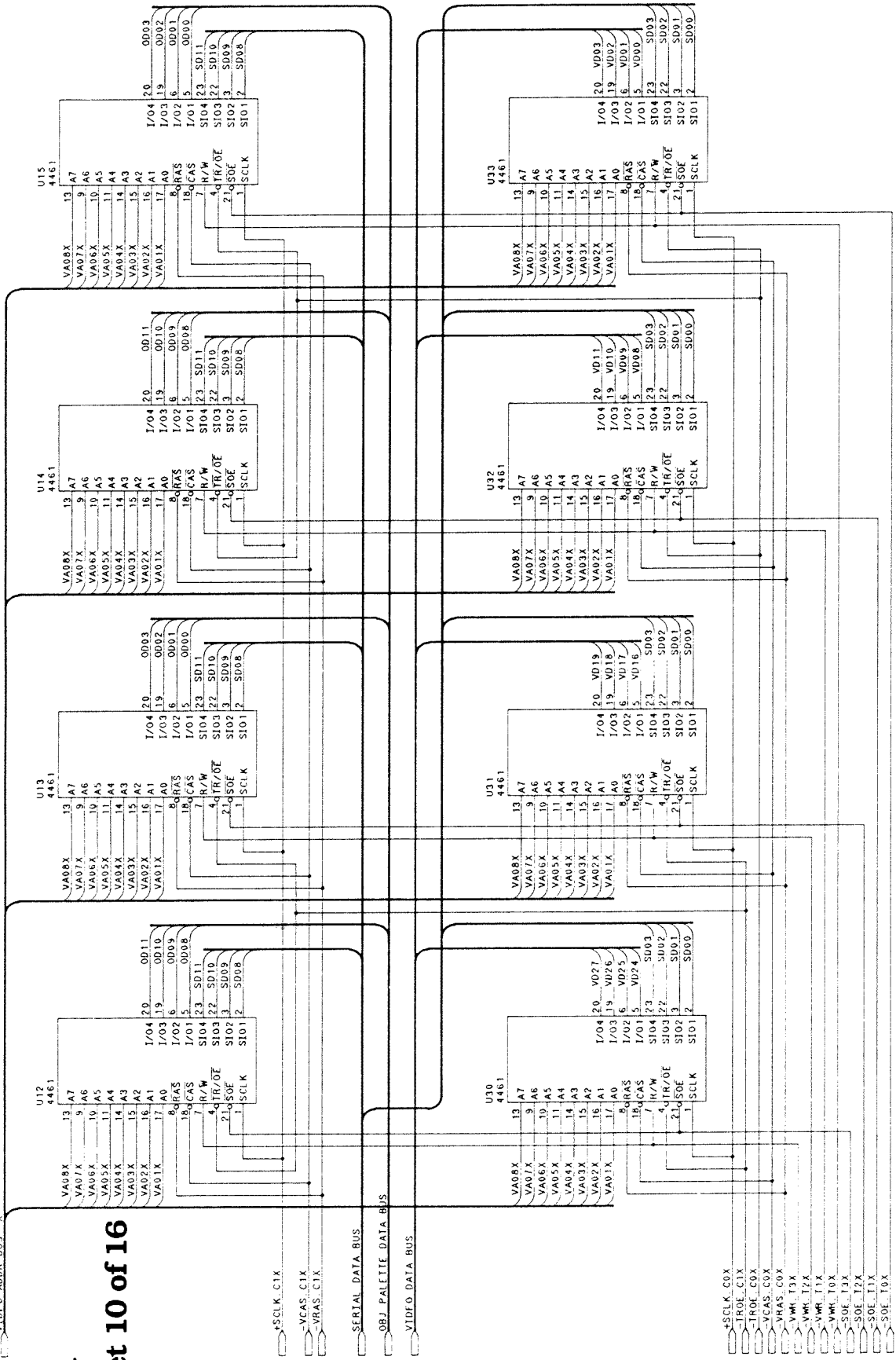

VIDEO ADDR BUS "X"

# CPU Sheet 11 of 16

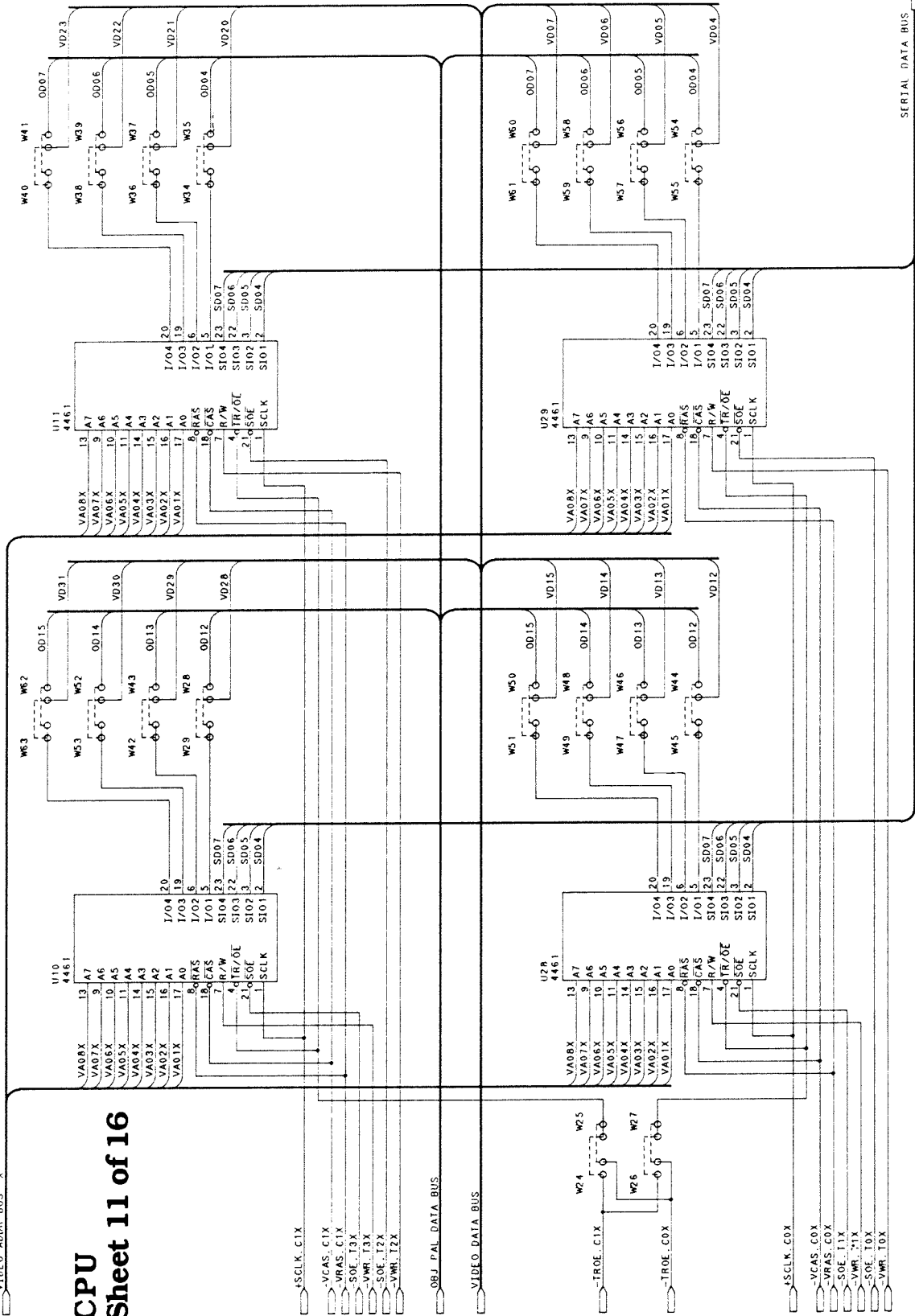

SERIAL DATA BUS





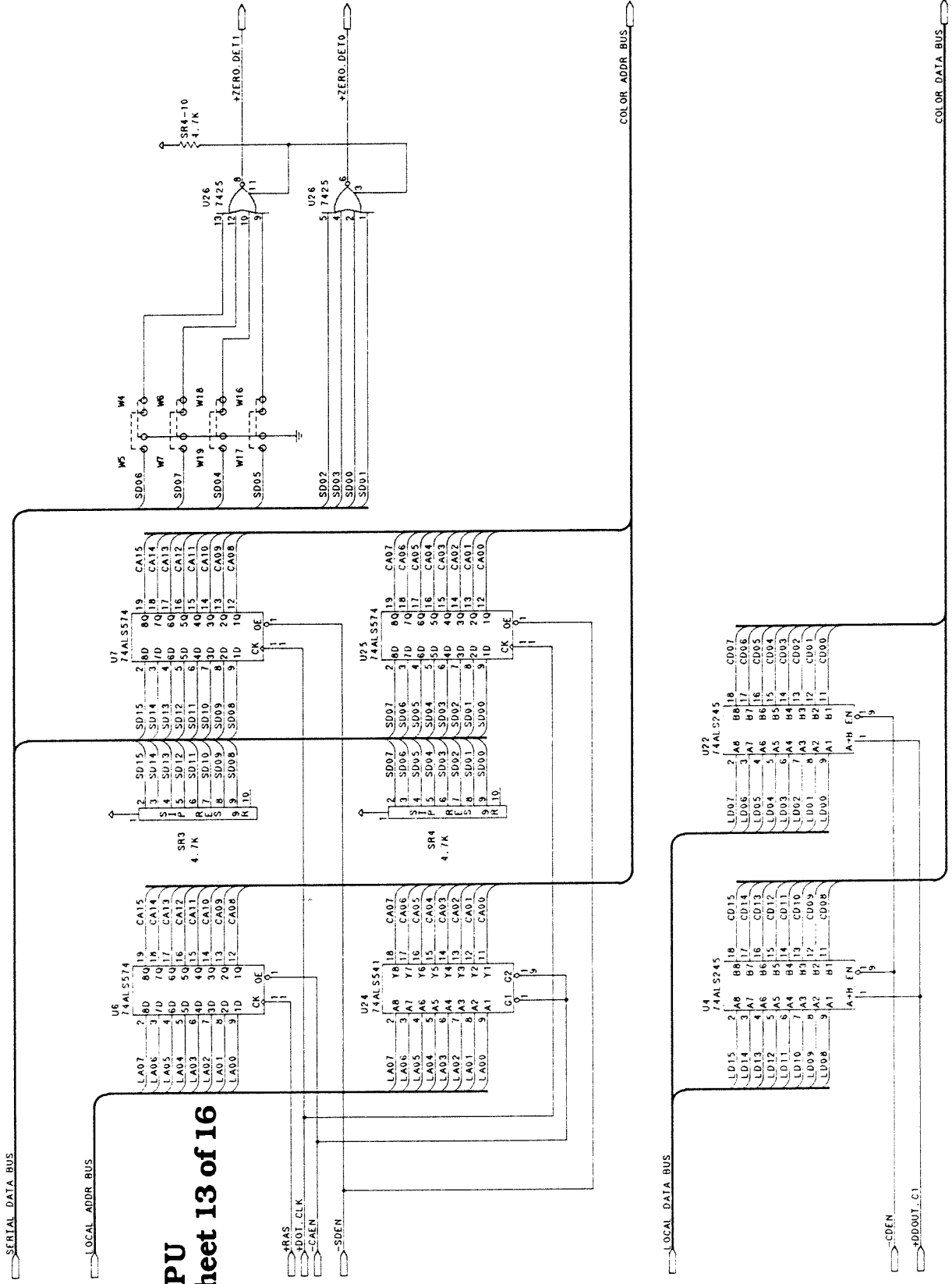

**CPU**  
**Sheet 13 of 16**

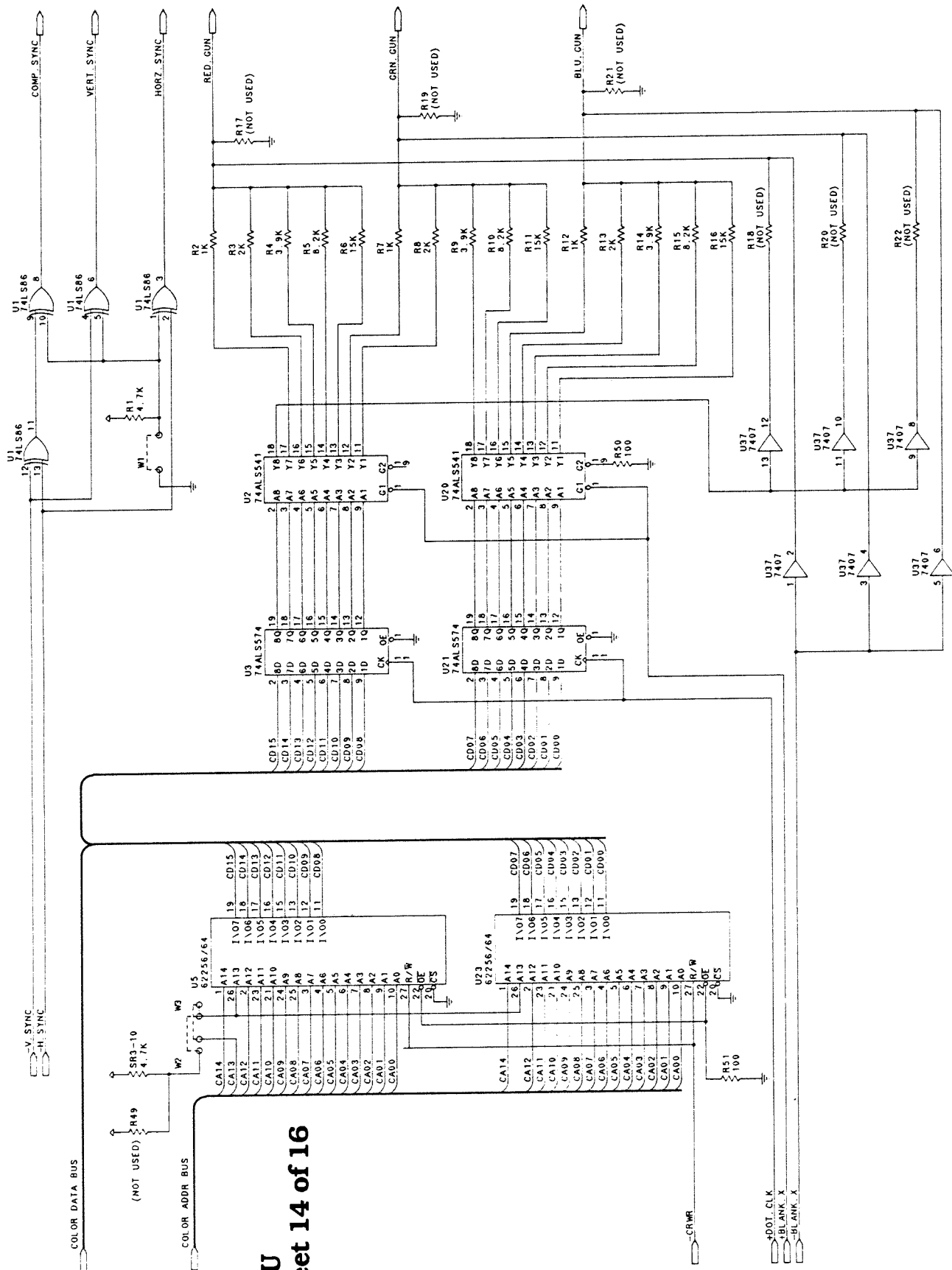

**CPU Sheet 14 of 16**

# CPU Sheet 15 of 16

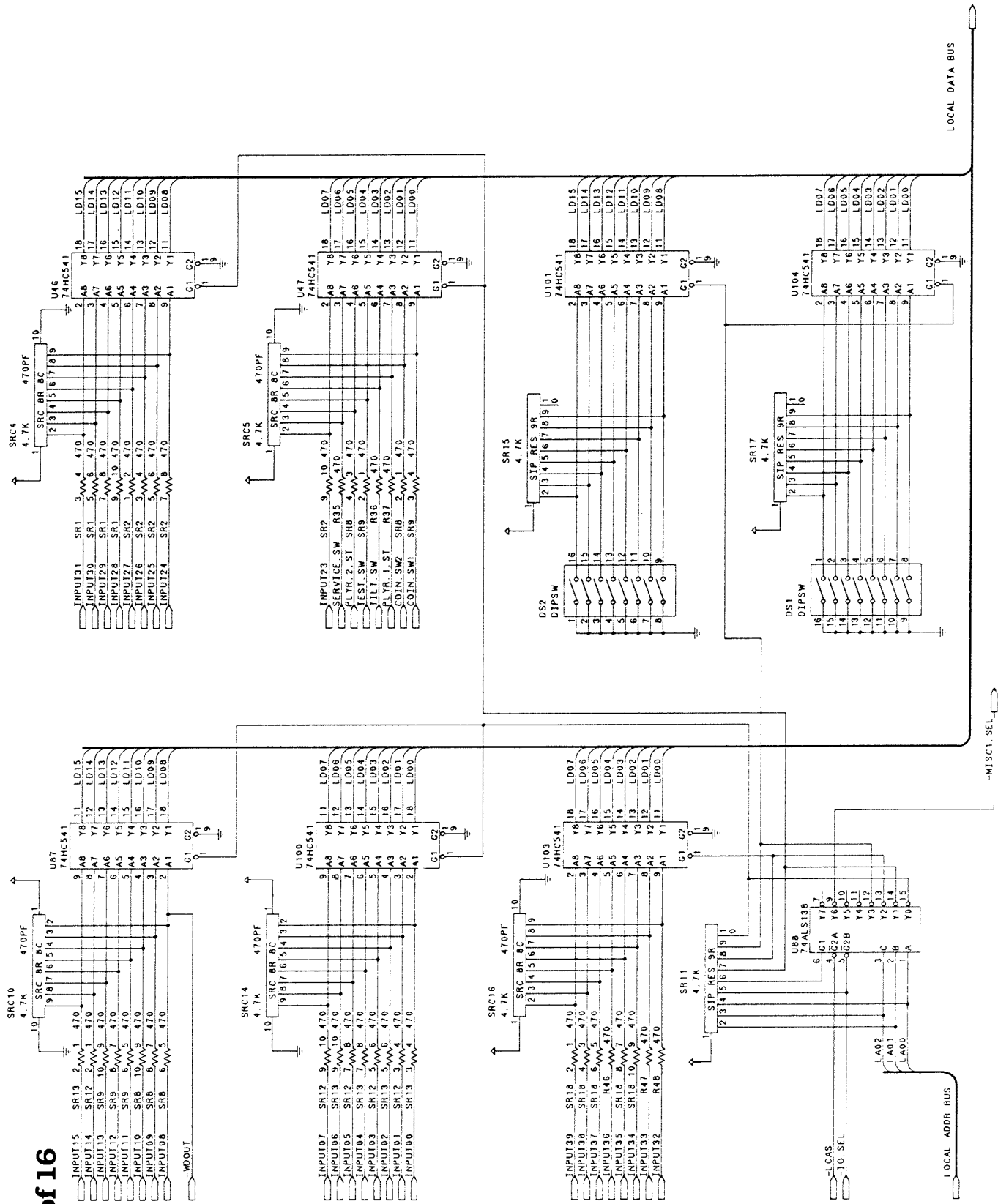



## Notes

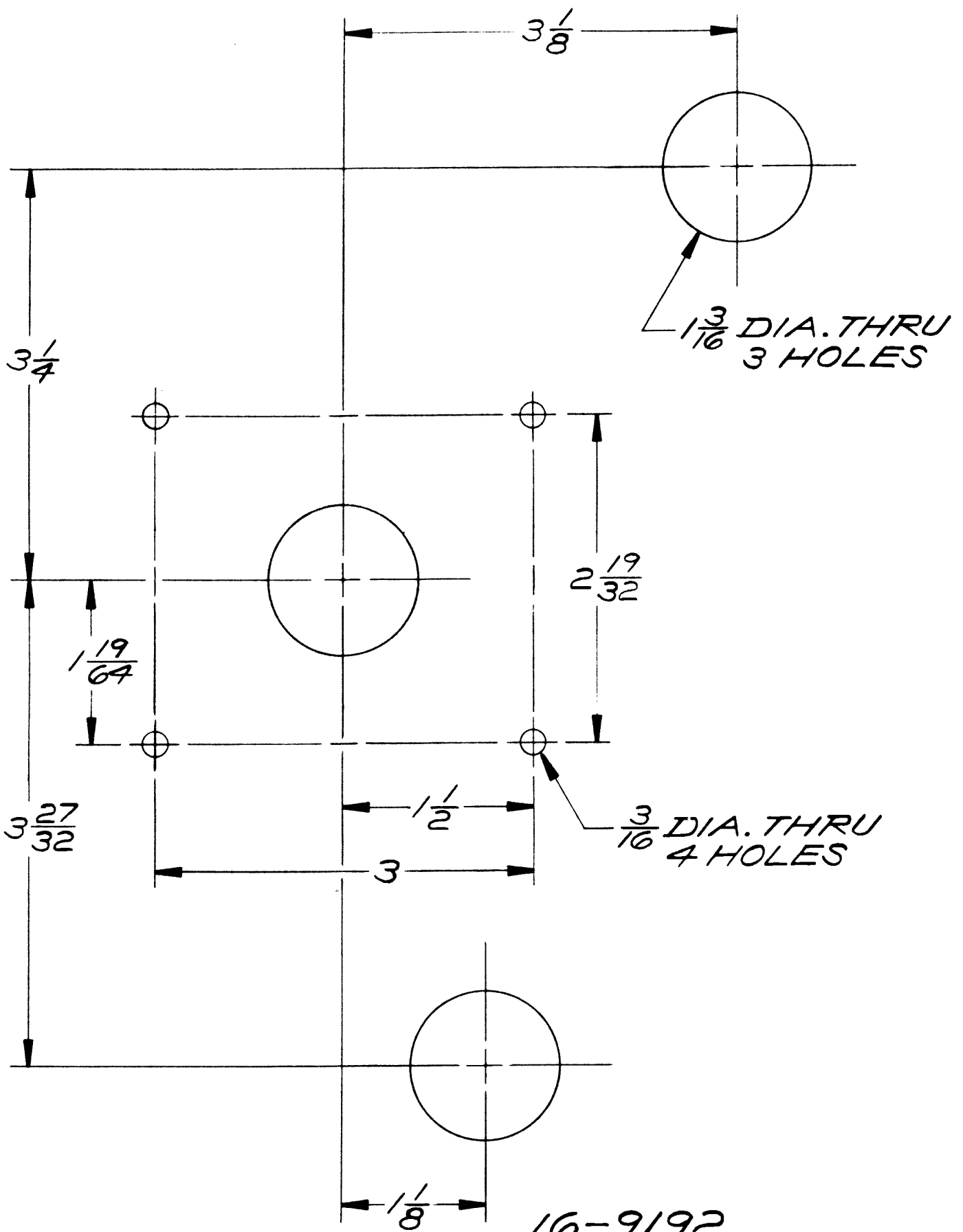

16-9192  
 TEMPLATE CONTROLS  
 PLAYER #1

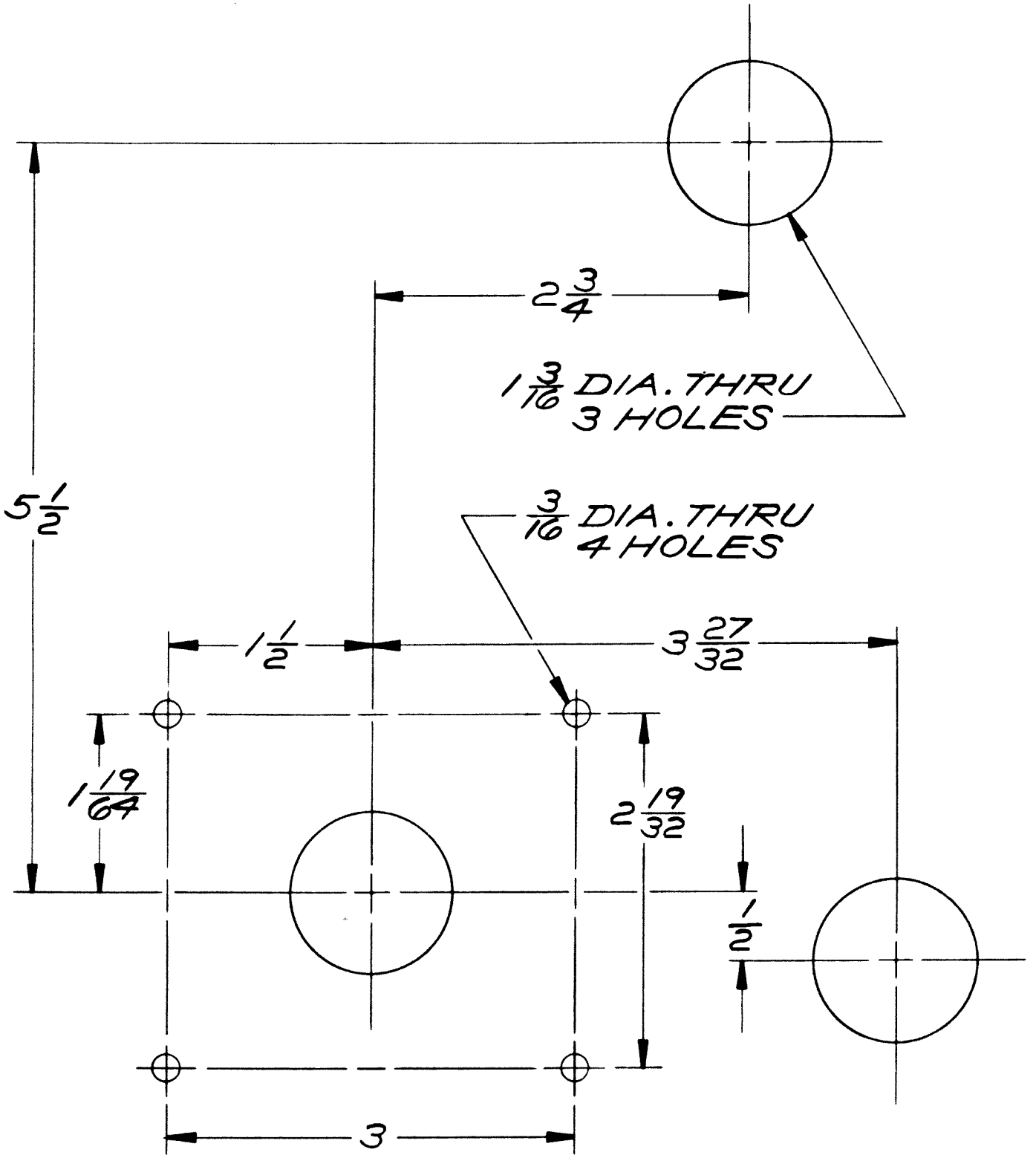

16-9192-1  
 TEMPLATE CONTROLS  
 PLAYER #2



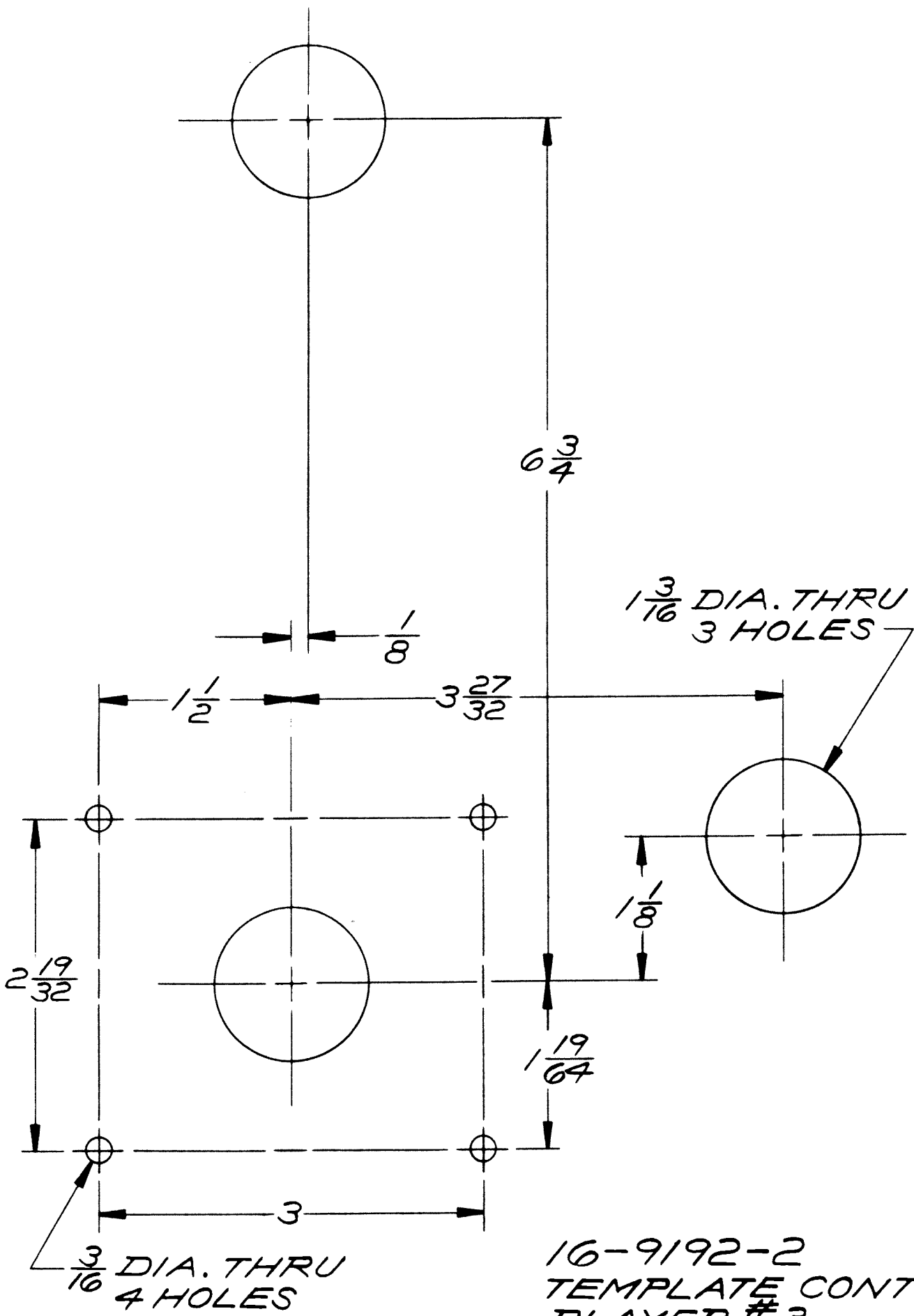

$\frac{3}{16}$  DIA. THRU  
3 HOLES

$\frac{3}{16}$  DIA. THRU  
4 HOLES

16-9192-2  
TEMPLATE CONTROLS  
PLAYER #3

3

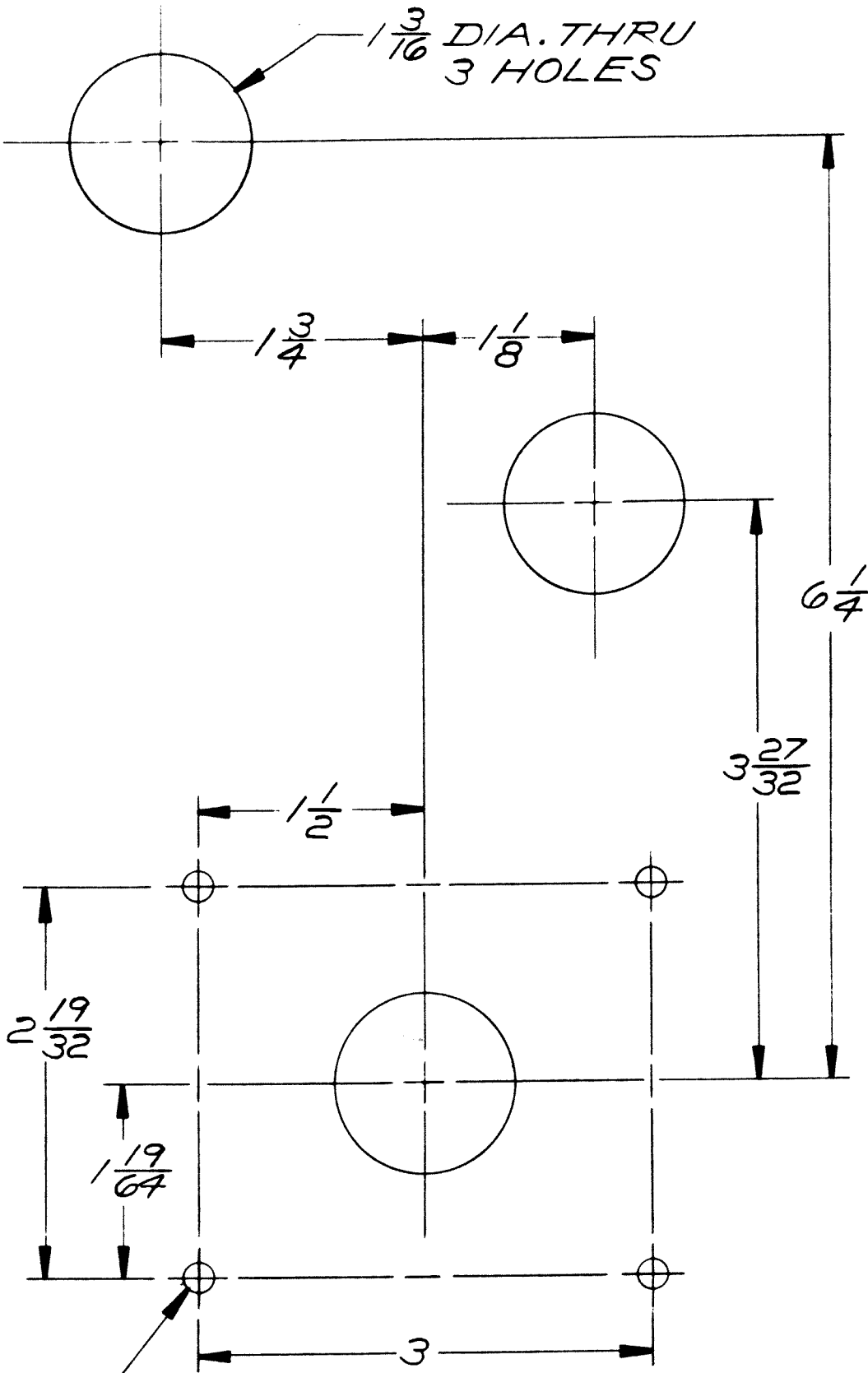

$\frac{3}{16}$  DIA. THRU  
4 HOLES

16-9192-3  
TEMPLATE CONTROLS  
PLAYER #4

## **WARNINGS & NOTICES**

### **Warning**

**USE OF NON-MIDWAY PARTS OR CIRCUIT MODIFICATIONS MAY CAUSE SERIOUS INJURY OR EQUIPMENT DAMAGE! USE ONLY MIDWAY AUTHORIZED PARTS.**

- \* For safety and reliability, substitute parts and modifications are not recommended.
- \* Substitute parts or modifications may void FCC type acceptance.
- \* This game is protected by federal copyright, trademark and patent laws. Unauthorized modifications may be illegal under Federal law. This also applies to MIDWAY logos, designs, publications and assemblies. Moreover, facsimiles of MIDWAY equipment (or any feature thereof) may be illegal under federal law, regardless of whether or not such facsimiles are manufactured with MIDWAY components.

### **Warning**

This equipment generates, uses and can emit radio frequency energy and, if not installed properly and used according to the directions in this manual, may cause interference to radio communications. It has been tested and found to comply with the limits for a Class A computing device pursuant to Subpart J of part 15 of FCC rules which are designed to provide reasonable protection against such interference when operated in a commercial environment. Operation of this equipment in a residential area is likely to cause interference to radio communications, in which the user, at his or her own expense, will be required to take whatever measures may be needed to correct the interference.

### **Warning**

Prevent shock hazard and assure proper game operation. Only plug this game into a properly grounded outlet. Do not use a cheater plug to defeat the power cord's grounding pin. Do not cut off the ground pin.

### **Notice**

**When MIDWAY ships a game, it is in compliance with FCC regulations. Your sticker is proof. If the sticker is missing or damaged, legal repercussions to the owner or distributor of the game may result. If your game does not contain an FCC sticker, call MIDWAY immediately.**

### **Notice**

No part of this publication may be reproduced by any mechanical, photographic, or electronic process, or in the form of a phonographic recording, nor may be transmitted, or otherwise copied for public or private use, without permission from the publisher.

**FOR SERVICE:  
CALL YOUR AUTHORIZED MIDWAY DISTRIBUTOR.**

**MIDWAY Manufacturing Company  
3401 N. CALIFORNIA AVE.  
CHICAGO, IL 60618**