



Atari Games Corporation

675 Sycamore Drive

P.O. Box 361110

Milpitas, CA 95035

TM-342
1st printing

SIKU CROSSING

**Universal Kit
Installation Instructions**

For technical assistance:

If reading through this manual does not lead to solving your game maintenance or repair problem, call TELE-HELP® at one of these Atari Games Customer Service offices:

UNITED STATES

Atari Games Corporation
California Customer Service Office
737 Sycamore Drive
P.O. Box 361110
Milpitas, CA 95035

Fax (408) 434-3945

Telex 5101007850

☎ (408) 434-3950

(Monday-Friday, 7:30 a.m.-4:00 p.m. Pacific time)

EUROPE

Atari Games Ireland Limited
European Customer Service Office
Tipperary Town, Ireland

Fax 062-51702

Telex 70665

☎ 062-52155

(Monday-Friday, 9:00 a.m.-5:30 p.m. GMT)

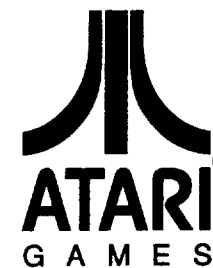

Skull & Crossbones™

Universal Kit Installation Instructions

with Parts Illustrations and Schematic Diagrams



© 1989 by Atari Games Corporation.
All rights reserved.

No part of this publication may be reproduced by any mechanical, photographic or electronic process, or in the form of a phonographic recording, nor may it be stored in a retrieval system, transmitted, or otherwise copied for public or private use, without permission from the publisher.

The game play, all graphic designs, this technical manual, its accompanying schematic diagrams, and the display manual are protected by the U.S. Copyright Act of 1976.

This Act provides for substantial penalties for violating federal copyright laws. Courts can impound infringing articles while legal action is pending. If infringers are convicted, courts can order destruction of the infringing articles.

In addition, the Act provides for payment of statutory damages of up to \$50,000 per infringing transaction in certain cases. Infringers may also have to pay costs and attorneys' fees and face an imprisonment of up to five years as well as fines of up to \$250,000 in the case of individuals and up to \$500,000 in the case of corporations.

Atari Games Corporation will aggressively enforce its copyrights against infringers. We will use all legal means to immediately halt any manufacture, distribution, or operation of a copy of video games made by us. Anyone who purchases such copies risks forfeiting such a game.

Published by:
Atari Games Corporation
675 Sycamore Drive
P.O. Box 361110
Milpitas, California 95035

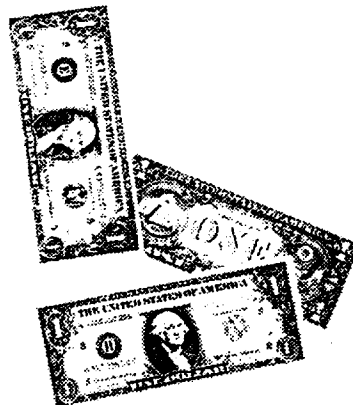

Printed in the U.S.A 11/89

Produced by the Atari Games Technical Publications Department.

Editing and Text Layout: Andrea Dencker
Illustration and Design: Mary Ohanessian Sumner

Notice Regarding Non-Atari® Parts

WARNING

Use of non-Atari parts or modifications of any Atari game circuitry may adversely affect the safety of your game, and may cause injury to you and your players.

You may void the game warranty (printed on the inside back cover of this manual) if you do any of the following:

- Substitute non-Atari parts in the game.
- Modify or alter any circuits in the game by using kits or parts *not* supplied by Atari Games Corporation.

Note

This equipment generates, uses, and can radiate radio frequency energy, and if not installed and used in accordance with the instruction manual, may cause interference to radio communications. It has been tested and found to comply with the limits for a Class A computing device pursuant to Subpart J of Part 15 of Federal Communications Commission (FCC) Rules, which are designed to provide reasonable protection against such interference when operated in a commercial environment. Operation of this equipment in a residential area or modification to this equipment is likely to cause interference, in which case the user, at his own expense, will be required to take whatever measures may be required to correct the interference. If you suspect interference from an Atari game at your location, check the following:

- All ground wires in the game are properly connected as shown in the game wiring diagram.
- The power cord is properly plugged into a grounded three wire outlet.
- On games provided with an Electromagnetic Interference (EMI) ground cage, be sure that the printed-circuit boards (PCBs) are properly installed on the EMI ground cage and that the end board is securely installed with **all** screws in place and tightened.

If you are still unable to solve the interference problem, please contact Customer Service at Atari Games Corporation. See the inside front cover of this manual for service in your area.

Table of Contents

1 Installation	
How to Use This Manual	1-1
Equipment Requirements	1-2
Tools Required	1-2
Preparing the Existing Game for Conversion ...	1-2
Inspecting the Kit	1-2
Installing the Kit Parts	1-3
Testing After Power-Up	1-7
Setting the Coin and Game Options	1-7
Game Play	1-7
2 Self-Test	
Self-Test	2-2
Statistics and Histogram Screens.....	2-2
Game Options.....	2-3
Coin Options.....	2-4
Sound Board Test	2-4
Switch Test.....	2-5
Complete RAM Test.....	2-5
Complete ROM Test	2-5
Playfield Test.....	2-6
Motion Object Test	2-6
Alphanumeric Test.....	2-6
Color Test.....	2-7
Color Purity Test.....	2-7
Convergence Test	2-7
3 Maintenance	
Preventive Maintenance	3-2
Maintaining the Joystick	3-2
Troubleshooting.....	3-2
Disassembling the Joystick.....	3-2
Reassembling the Joystick.....	3-3
4 Illustrated Parts Lists	
5 Schematic Diagrams	
Skull & Crossbones Statistics Sheet	
Warranty	

List of Illustrations

Figure 1-1	Installing the Kit Parts	1-3
Figure 2-1	RAM Error Message.....	2-2
Figure 2-2	ROM Error Message.....	2-2
Figure 2-3	Switch Test Screen.....	2-2
Figure 2-4	Coin Options Screen.....	2-3
Figure 2-5	Game Options Screen.....	2-3
Figure 2-6	First Statistics Screen.....	2-4
Figure 2-7	Second Statistics Screen.....	2-5
Figure 2-8	Playfield Scrolling Test.....	2-5
Figure 2-9	Motion Object Test.....	2-6
Figure 2-10	Alphanumerics Test	2-6
Figure 2-11	Color Test.....	2-6
Figure 2-12	Color Purity Test	2-6
Figure 2-13	Convergence Test.....	2-7
Figure 2-14	Sound Test.....	2-7
Figure 3-1	Opening the Control Panel	3-3
Figure 3-2	Maintaining the Joystick	3-4
Figure 3-3	Removing the Video Display	3-9
Figure 4-1	Cabinet-Mounted Assemblies, Front View.....	4-2
Figure 4-3	Control Panel Assembly.....	4-8
Figure 4-4	Joystick Assembly	4-10
Figure 4-5	Coin Controls, Inc. Coin Door Assembly	4-12
Figure 4-6	Power Supply Assembly	4-14
Figure 4-7	Cyberball 2072 Game PCB Assembly ...	4-16
Figure 4-8	JSA Audio II PCB Assembly.....	4-20

List of Tables

Table 1-1	Game Specifications	1-2
Table 2-1	RAM Error Locations	2-2
Table 2-2	ROM Error Locations.....	2-2
Table 2-3	Coin Option Settings	2-3
Table 2-4	Regions	2-4
Table 2-5	Game Option Settings.....	2-4
Table 2-6	Faulty Sound RAM and ROM Locations	2-8
Table 3-1	Maintenance and Inspection Items.....	3-2
Table 3-2	Troubleshooting Table	3-6
Table 3-3	Voltage Inputs and Test Points on the PCBs.....	3-7
Table 3-4	What ROM Problems Look Like	3-8

Safety Summary

The following safety precautions apply to all game operators and service personnel. Specific warnings and cautions will be found in this manual whenever they apply.

WARNING

Properly Ground the Game. Players may receive an electrical shock if this game is not properly grounded! To avoid electrical shock, do not plug in the game until it has been inspected and properly grounded. This game should be only be plugged into a grounded three-wire outlet. If you have only a two-wire outlet, we recommend you hire a licensed electrician to install a three-wire grounded outlet. If the control panel is not properly grounded, players may receive an electrical shock! After servicing any part on the control panel, check that the grounding wire is firmly secured to the inside of the control panel. After you have checked this, lock up the game.

AC Power Connection. Before you plug in the game, be sure that the game's power supply can accept the AC line voltage in your location. The line voltage requirements are listed in the first chapter of this manual.

Disconnect Power During Repairs. To avoid electrical shock, disconnect the game from the AC power before removing or repairing any part of the game. If you remove or repair the video display, be very careful to avoid electrical shock. High voltages continue to exist even after power is disconnected in the display circuitry and the cathode-ray tube (CRT). Do not touch the internal parts of the display with your hands or with metal objects! Always discharge the high voltage from the CRT before servicing it. Do this after you disconnect it from the power source. First, attach one end of a large, well-insulated, 18-gauge jumper wire to ground. Then momentarily touch the free end of the grounded jumper wire to the CRT anode by sliding the

wire under the anode cap. Wait two minutes and do this again.

Use Only Atari Parts. To maintain the safety of your Atari game, use only Atari parts when you repair it. Using non-Atari parts or modifying the game circuitry may be dangerous, and could injure you and your players.

Handle the CRT With Care. If you drop the CRT and it breaks, it may implode! Shattered glass from the implosion can fly six feet or more.

Use the Proper Fuses. To avoid electrical shock, use replacement fuses which are specified in the parts list for this game. Replacement fuses must match those replaced in fuse type, voltage rating, and current rating. In addition, the fuse cover must be in place during game operation.

CAUTION

Properly Attach All Connectors. Make sure that the connectors on each printed circuit board (PCB) are properly plugged in. The connectors are keyed to fit only one way. If they do not slip on easily, do not force them. If you reverse a connector, it may damage your game and void your warranty.

Ensure the Proper AC Line Frequency. Video games manufactured for operation on 60 Hz line power (used in the United States) must not be operated in countries with 50 Hz line power (used in Europe). If a 60 Hz machine operates on 50 Hz line power, the fluorescent line ballast transformer will overheat and cause a potential fire hazard. Check the product identification label on your machine for the line frequency required.

ABOUT NOTES, CAUTIONS, AND WARNINGS

In Atari publications, notes, cautions and warnings have the following meaning:

NOTE—A highlighted piece of information.

CAUTION—Equipment and/or parts can be damaged or destroyed if instructions are not followed. You will void the warranty on Atari printed-circuit boards, parts thereon, and video displays if equipment or parts are damaged or destroyed due to failure of following instructions.

WARNING—Players and/or technicians can be killed or injured if instructions are not followed.



Chapter 1 Installation

How to Use This Manual

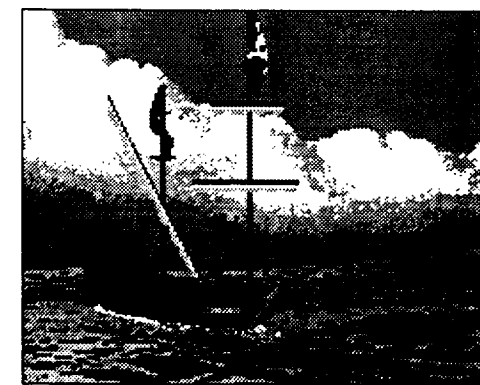

This manual provides information for installing, testing, and troubleshooting the Skull & Crossbones universal kit. The manual is divided into the following chapters: ■ Chapter 1 describes the installation procedure and the Skull & Crossbones game play. ■ Chapter 2 contains self-test procedures. ■ Chapter 3

contains troubleshooting procedures. ■ Chapter 4 contains illustrated parts lists. ■ Chapter 5 contains the schematics for the game PCB and the JSA Audio II PCB.

Also bound into Chapter 1 of this manual is the template for drilling the holes into the Skull & Crossbones control panel.

WARNING

To avoid electrical shock, unplug the video game cabinet during the conversion. After inspection, plug it only into a grounded 3-wire outlet.

Equipment Requirements

See Table 1-1 for the equipment required in the cabinet in which you are installing the Skull & Crossbones kit.

Table 1-1 Equipment Requirements for the Skull & Crossbones Game

Equipment	Specification
Video Display	<ul style="list-style-type: none"> ■ Color RGB monitor ■ Separate positive horizontal and vertical sync or negative composite sync ■ Horizontal mounting ■ Horizontal frequency 15.750 KHz ■ Vertical frequency 60 Hz ■ Recommended size: 19 inch ■ Video input 1V to 3V peak-to-peak positive polarity
Control Panel	Metal preferred
Space Below Control Panel	At least 4 1/2 inches deep
Speaker	8 Ohms 10 Watts
Coin Mechanism	+5 VDC or +12 VDC
Power Cord	Three-conductor with ground
Power Supply	<ul style="list-style-type: none"> +5 VDC ± 0.25V @ 7.0 amps +12 VDC ± 0.5V @ 1.0 amp -5 VDC ± 0.5V @ 1.0 amps

CAUTION

Do not unplug or plug in the Skull & Crossbones Game printed-circuit board (PCB) edge connector while the power is on. You could seriously damage the PCB.

Tools Required

- Two C-clamps
- Drill with 1/4 inch drill bit, a 1 3/16-inch hole cutter (or 1 3/16-inch chassis punch), and a 1 3/4-inch hole cutter
- Phillips screwdriver
- Flat-blade screwdriver
- Socket set
- Wire cutters and strippers
- Straightedge
- Squeegee
- X-ACTO™ knife
- Fast-ons (if you are installing a new JAMMA harness)

Preparing the Existing Game for Conversion

1. Turn off power to the game.
2. Remove the old game PCB(s). Remove the game harness if it is not Japan Amusement Machinery Manufacturers Association (JAMMA)-compatible.
3. Remove all the control panel decals, labels, and controls.
4. Remove any side decals from the cabinet. If your cabinet has wood grain or laminate sides, remove the old graphics and adhesive. If the sides are damaged, repair them before putting on the new decals.
5. Remove and clean the video display plexiglass, display bezel, attraction shield, and marquee, if any.
6. Paint the cabinet, if required.
7. Wipe down and vacuum the cabinet as necessary, including the face of the display.

Inspecting the Kit

Check to see that you have all the parts listed in the kit parts list in Table 1-2. If any part is missing or damaged, please contact your distributor with the Skull & Crossbones kit serial number, part number and description of any missing or damaged parts, and date received.

Installing the Kit Parts

Display Bezel

Find the display bezel (part no. 047451-01). Measure the size of the existing display bezel and cut the new display bezel to size, if necessary. (See Figure 1-1.)

Product ID and FCC Label

Place the product ID label (part no. 038158-01) and FCC label (part no. 039450-01) on the back of the cabinet.

Side Decals

Find the side panel decals (part no. 047053-01). Wet the left and right side panels of the cabinet with slightly soapy water. Then position the decals as desired. Remove any wrinkles in the artwork using a squeegee. Allow the sides to dry.

Attraction Shield

Find the attraction shield (part no. 047205-01) and the attraction film (part no. 047452-01). Using the existing shield as a template, cut the shield and film to size, if necessary. Install them on the cabinet as shown in Figure 1-1.

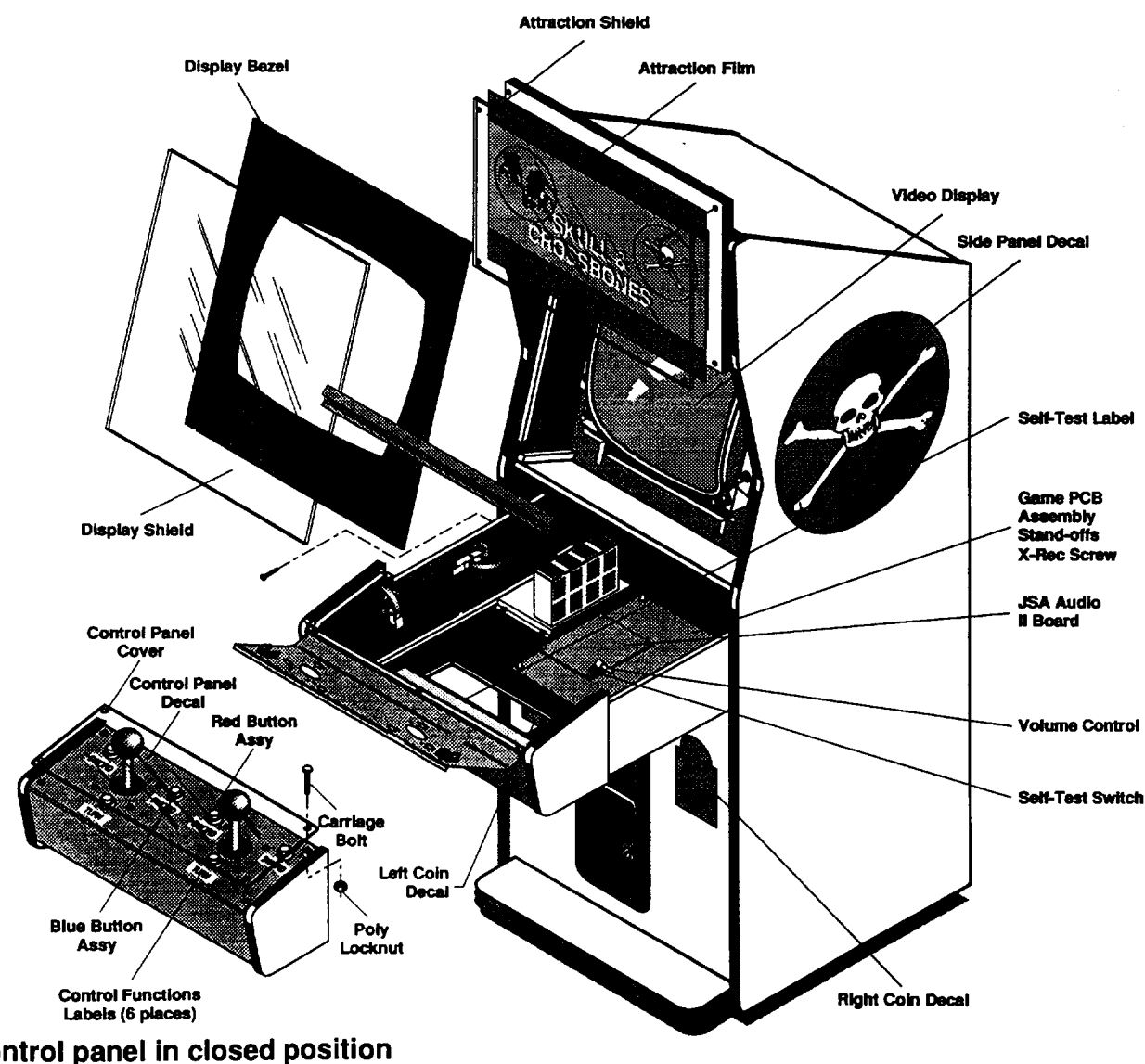

Figure 1-1 Installing the Skull & Crossbones Game Parts

Table 1-2 Kit Contents Checklist

Received?	Item
<input type="checkbox"/>	Skull & Crossbones Game Board Set (consists of the Game PCB and JSA Audio II PCB Assemblies)
<input type="checkbox"/>	JAMMA Harness Assy
<input type="checkbox"/>	Display Bezel
<input type="checkbox"/>	Attraction Film with Graphics
<input type="checkbox"/>	Attraction Shield
<input type="checkbox"/>	Control Panel Decal
<input type="checkbox"/>	Set of Control Functions Labels
<input type="checkbox"/>	Control Panel Cover
<input type="checkbox"/>	Two Side Panel Decals
<input type="checkbox"/>	Left Coinage Decal
<input type="checkbox"/>	Right Coinage Decal
<input type="checkbox"/>	Product Identification Label
<input type="checkbox"/>	FCC Label
<input type="checkbox"/>	Skull & Crossbones Universal Kit Installation Instructions
<input type="checkbox"/>	Two 8-Position Microswitch Joysticks
<input type="checkbox"/>	Three Red Button Assemblies
<input type="checkbox"/>	Three Blue Button Assemblies
<input type="checkbox"/>	Six Snap-Action Switches
<input type="checkbox"/>	Four Nylon Standoffs
<input type="checkbox"/>	Four Type AB #6 Screws
<input type="checkbox"/>	Twelve Black #10 Carriage Bolts
<input type="checkbox"/>	Twelve #10 Poly Locknuts

Packaging materials are not included in this list.

Control Panel

Unpack the Skull & Crossbones Game control panel cover (part no. 047209-01) and control panel decal (part no. 047453-01). Measure your control panel to find out what size the decal and cover should be. Cut the control panel decal and cover to fit.

Drilling Holes in the Control Panel Cover

1. Clamp the control panel cover to the control panel.
2. Drill four corner holes through the control panel and the control panel cover. Use a 1/4-inch drill bit.
3. Install four carriage bolts and locknuts through the holes to hold the cover and the control panel together.
4. Cut the control panel template out of the manual (see the end of this chapter). Make an actual-size copy of it.
5. Tape the two templates next to each other on the control panel cover. See Figure 1-2 for the controls arrangement.
6. Cut the holes in the cover and panel as shown by the templates using a 1 3/16-inch hole cutter for the button holes and a 1 3/4-inch hole cutter for

the joystick knob holes. Use a 1/4-inch drill bit to drill the mounting holes for the joysticks.

Installing the Control Panel Decal and Labels

1. Disassemble the control panel and the control panel cover. Deburr the holes in the cover and the panel.
2. Install the control panel decal on the control panel. Using a sharp knife, cut out the holes for the controls in the decal.
3. Put the control labels on the control panel. (See Figure 1-2.)
4. Install the cover on the control panel with four carriage bolts and locknuts.

Installing the Controls

1. Install the black player control buttons on the left player and the white player control buttons on the right. (See Figure 1-2.)

NOTE

After the buttons are tightened on the control panel, you can put a small amount of clear RTV silicon on two or three areas of the locknut to prevent the buttons from being unscrewed from the top.

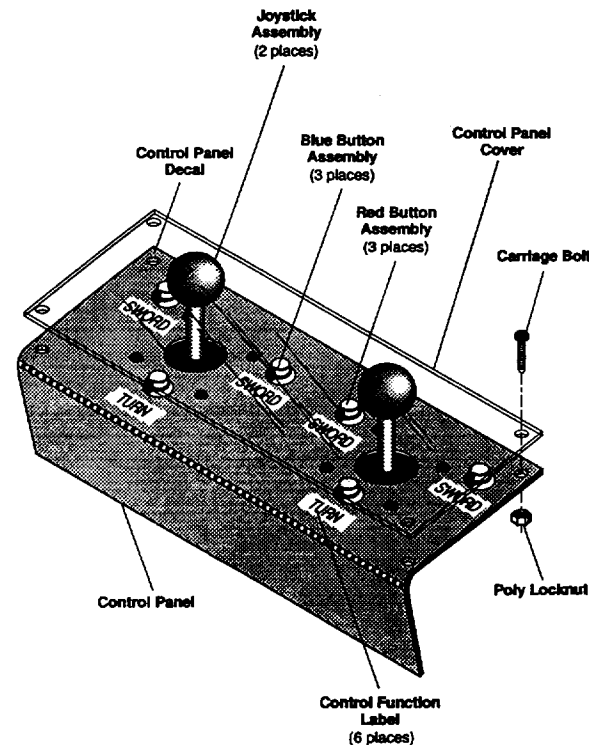

Figure 1-2 Assembling the Control Panel and Cover

2. Mount each joystick assembly on the control panel with four carriage bolts and locknuts. Install the joysticks so the Atari Games logos are upright. See Figure 1-2.
3. Install the joystick harnesses on each joystick.

General Harness Installation

1. If your game does not already have a JAMMA harness, find the JAMMA harness (part no. A046501-01) in the kit and install it.
2. Using Table 1-3, *JAMMA Pin and Wire Connections*, for wiring information, connect the JAMMA harness to existing component harnessing. You can do this using crimp splices or by butt soldering.

WARNING

Do not simply tie the wires together. If you do, you could cause intermittent problems, loose connections, oxidation, or even a fire.

Connecting Power Wires

1. Connect the wires on the JAMMA harness to the wires for the power supply. You need +5V, -5V, and +12V for the Skull & Crossbones Game. This kit may not require all of the voltages used in your original game. Tie off any unused wires on the power supply.
2. You will notice that there is more than one wire for each voltage. You must use more than one wire, as called out in the footnotes of Table 1-3. Using more than one wire for each voltage ensures that you do not overload the edge connector and cause it to burn.

Connecting Video Display Wires

Connect the wires designated for the RED, GREEN, and BLUE video guns along with the sync and ground wires.

NOTE

The JAMMA harness provides only negative composite sync. However if your video display requires separate positive sync, see Chapter 3 for alternative wiring.

Connecting Coin Door Wires

1. Connect the wires on the JAMMA harness to the coin switches and meter.
2. Connect one side of the door lamps to one of the BK/W wires. Connect the other side of the door

lamps to the R wire supplying +5V to the joysticks.

NOTE

Do not use -5V for the coin door lamps. -5V is required for audio.

(Some games have separate power supply outputs for the coin door lamps. If you choose to use these outputs, make sure you connect both sides of the lamps to the terminals on the power supply.)

3. Be sure to clean the coin mechanisms; however, do not lubricate the coin mechanisms.

Connecting the Control Wires

Connect the joystick wires to the JAMMA harness according to the information in Table 1-3. The test screen is in the game self-test, explained in Chapter 2.

Grounding the Cabinet

WARNING

Consult a licensed electrician if you're not clear about the following grounding procedure. An improperly connected power cord is hazardous and can cause fatal injuries to players and/or technicians.

Find the ground lead (green) of the 115V input power line. Connect this lead in daisy-chain fashion to a bare metal part of the coin door, control panel, video display, and power supply. *This is a safety requirement for the players' protection.* This AC ground must be of #18 AWG wire or larger.

Checking the Cabinet Systems

Before plugging in the game PCB, turn on the power to the game, and check +5 Volts on pins 3, 4, C, and D of the JAMMA connector; +12 Volts on pins F and 6; and -5 Volts on pins E and 5. Check that the video display and the attraction lamp have power.

The above voltages should be measured, using a voltmeter, with respect to pin 1 (BN wire) and ground.

Now turn off the power to the game.

WARNING

Always power down before installing or removing the game or JSA Audio II board. Components on these PCBs are very sensitive to power spikes. Removal or installation while the power is on can damage your game board.

Table 1-3 JAMMA Pin and Wire Connections

Solder Side			Component Side			
Signal	Note (See Below)	Wire Color	Pin	Wire Color	Note (See Below)	Signal
+V RTN	1	BN	A 1	BN	1	+V RTN
+V RTN	1	BN	B 2	BN	1	+V RTN
+5V	2	R	C 3	R	2	+5V
+5V	2	R/W	D 4	R/W	2	+5V
-5V	3	OR	E 5	OR	3	-5V
+12V	4	Y	F 6	Y	4	+12V
Key			H 7			Key
COIN CTR 2	5	V/W	J 8	BU/W	5	COIN CTR 1
			K 9			NOT USED
SPKR-	TP	W	L 10	BN	TP	SPKR +
AUDIO GND			M 11			NOT USED
GREEN	6	GN	N 12	R	6	RED
SYNC	6	BN	P 13	BU	6	BLUE
SERVICE SW	NC	GY	R 14	BK	6	VIDEO RTN
			S 15			NOT USED
Right Player						Left Player
COIN 2	8	BK/OR	T 16	BK/Y	8	COIN 1
CREDIT 2	9, 11	Y/BK	U 17	W/BK	9, 11	CREDIT 1
UP 2	9	Y/BN	V 18	W/BN	9	UP
DOWN 2	9	Y/R	W 19	W/R	9	DOWN 1
LEFT 2	9	Y/OR	X 20	W/OR	9	LEFT 1
RIGHT 2	9	Y/W	Y 21	W/Y	9	RIGHT 1
SWORD 2	9	Y/GN	Z 22	W/GN	9	SWORD 1
TURN 2	9	Y/GN	a 23	W/BU	9	TURN 1
SWITCH C2	NC	Y/V	b 24	W/V	NC	SWITCH C1
LT/RT 2	NC	Y/GY	c 25	Y/GY	NC	LT/RT1
UP/DN 2	NC	GY/W	d 26	V	NC	UP/DN 1
GND	10	BK/W	e 27	BK/W	10	GND
GND	10	BK/W	f 28	BK/W	10	GND

Notes

NC means no connection required for Skull & Crossbones. TP means twisted pair.

1. Connect four of the large BN wires to the 5V RTN (GND) terminal on the power supply unless the power supply has a 12V RTN. If there is a 12V RTN, connect one of the wires to the 12V RTN (GND) terminal.
2. The R wires go to the +5V terminal on the power supply. If the power supply has a +SENSE terminal, connect one of these four wires to the +SENSE instead of the +5V.
3. Connect both wires to the -5V terminal of the power supply.
4. Connect both wires to the +12V terminal of the power supply. (If your coin counter(s) require(s) 12V, you can use one of these two wires for the + side of the coin counter(s).)
5. Connect to the negative side of the coin counter(s). If your counter(s) require 5V, you will need to splice into the red wire that supplies +5V. See Note 2, above. *Note: Do not use 24V counters.*

6. Attach to the video display.
7. Use this wire if you want an external self-test switch. However, the Skull & Crossbones game already has one self-test switch on the JSA Audio II PCB. If you connect an external self-test switch, first make sure the switch on the PCB is turned off. Then connect this wire to the N.O. terminal on the external self-test switch. Connect the common terminal of the self-test switch to one of the BK/W wires (GND).
8. Connect to the N.O. terminals of the two coin switches. Connect the common terminals of the coin switches to one of the BK/W wires.
9. Connect to the N.O. terminals of the start/select switches. Connect the common terminals of the switches to one of the BK/W wires.
10. Connect one wire to the negative sense terminal of the power supply (if it exists). Connect the second wire to the common terminals of the coin switches. Connect the fourth wire to the common terminals of the control switches.
11. Used with an electronic coin mechanism (Europe).

Installing the Skull & Crossbones Printed-Circuit Boards

1. Find the Skull & Crossbones Game PCB Assembly (part no. A046903-01) and JSA Audio II PCB Assembly (part no. A047184-02) and install them inside the cabinet. Use the nylon standoffs in the kit.
2. Connect the JAMMA connector to the PCB.
3. Apply power to the game. Check that the game PCB functions. If a video picture is not present, refer to Chapter 3.

Testing After Power-Up

Use the self-test to check the operation of the game. Refer to Chapter 2 for information about the self-tests.

We suggest that you perform a self-test when you first set up the game, each time you collect the money, or when you suspect game failure.

Setting the Coin and Game Options

The Skull & Crossbones coin and game options are set during the self-test. See Chapter 2 for information about the option settings.

Game Play

This section of the manual describes the theme of the Skull & Crossbones game and the game play features.

Introduction

Skull & Crossbones is a swashbuckling adventure in which players portray two pirates competing for food, drink, booty, and revenge. Players use a joystick and button to control the unique sword-fighting action.

Playing the Game

The game begins with an encounter with the evil Wizard, who robs our heroes of all of their booty. The pirates swear revenge and set off on a quest to destroy the Wizard and recover their treasure.

The adventure takes them around the world. The pirates battle the fierce captains and crews of opponent ships. They encounter the soldier guards and the merciless Executioner in the Spanish castle. In the ninja camp they fight the Ninja Master and his followers. On the beach the heroes encounter the dreaded Medusa and a horde of wicked skeletons that rise from the dead.

Finally, the pirates reach the Wizard's Island, where they must again do battle against the

shadow figures of the Executioner, the Ninja Master, and the Medusa before they can fight face-to-face with the evil Wizard. If they make it to the throne room and overcome the Wizard, players are rewarded with a room full of treasure.

Players use a joystick and sword button in a combination of defensive and offensive maneuvers to battle the various enemies. Players can learn the lunge and backslash, two skilled sword-fighting moves that are the most effective.

In order to increase the long-term appeal of the game, players can select various difficulty levels of easy, medium, and hard to vary their paths through the game. By selecting the longer hard path, players are rewarded with more food, drink, and booty along the way.

Game Play Hints

Stand over the white crossed bones that mark the spot of buried treasure and press the sword button to dig it up. Walk over the treasure to collect it.

In order to get the highest score, first start the digging, then battle the opponents on each screen. Collect all the treasure before moving on to the next scene.

The most difficult opponents in each wave (ship captains, Executioner, Ninja Master and Medusa) each protect a special treasure. By destroying these enemies, the players are given the special item that will protect them in the final round on the Wizard's Island.

In a two-player game, the two players must duel over these special treasures.

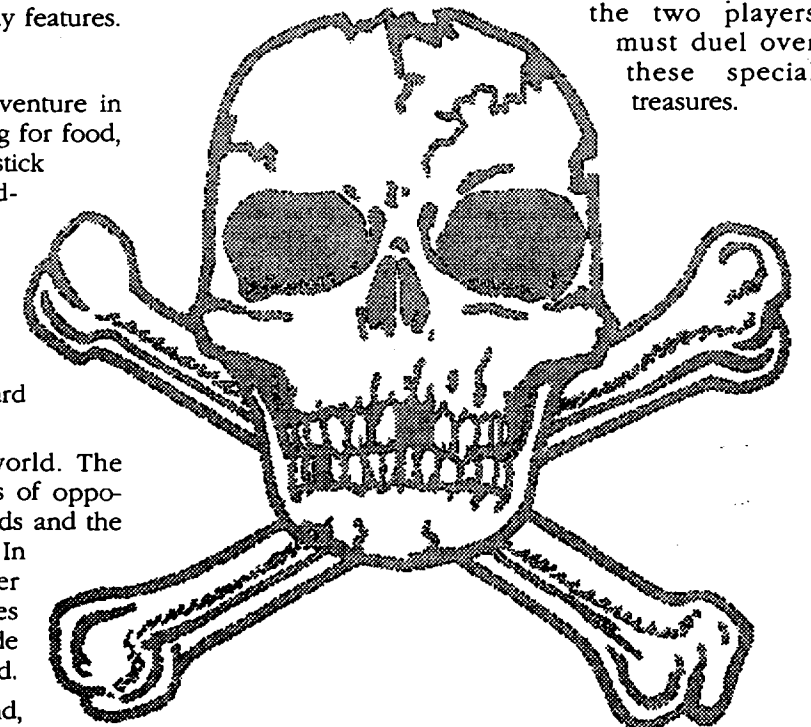

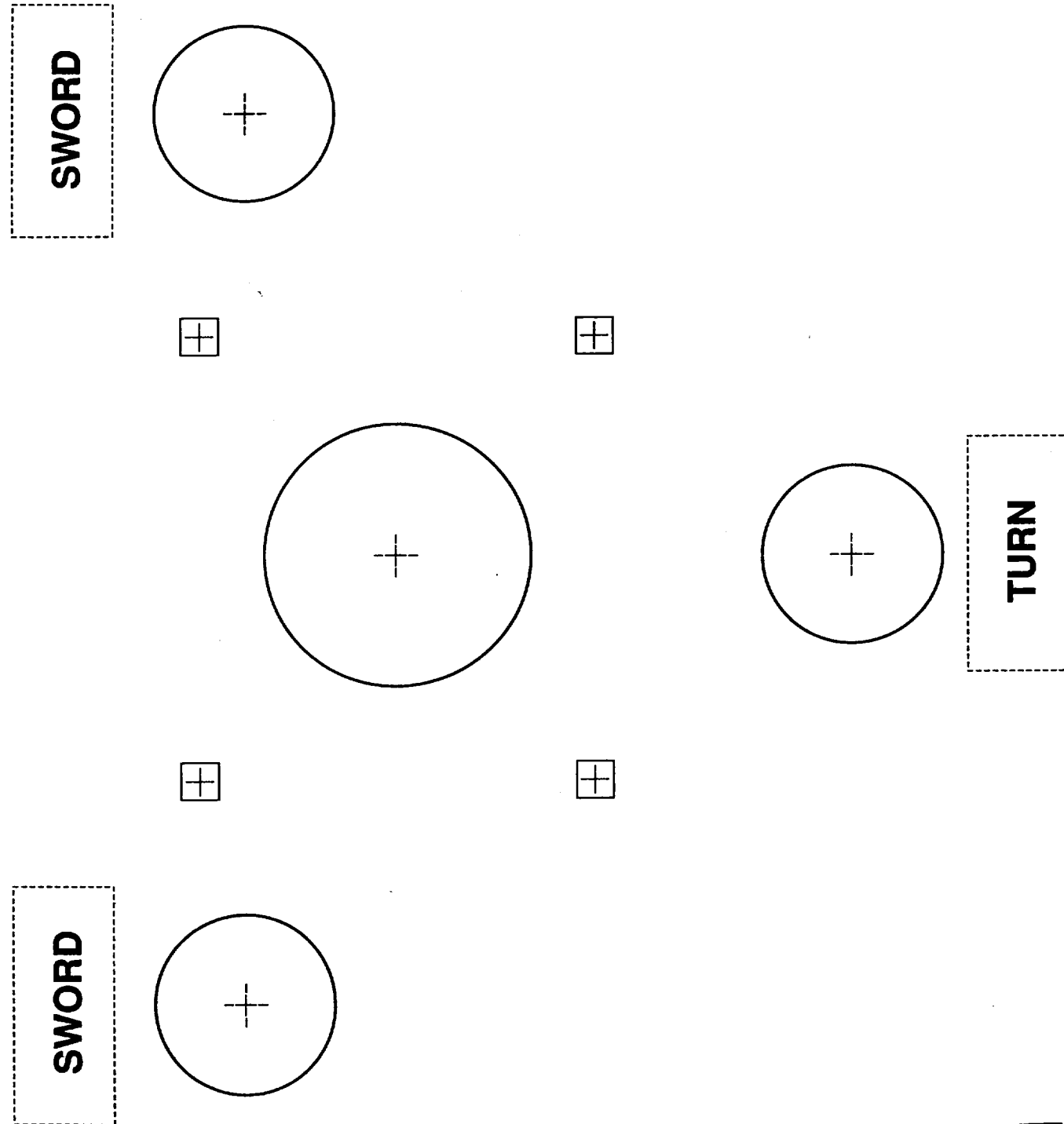

Use a copy of this template for the second set of player controls.

Chapter 2

Self-Test

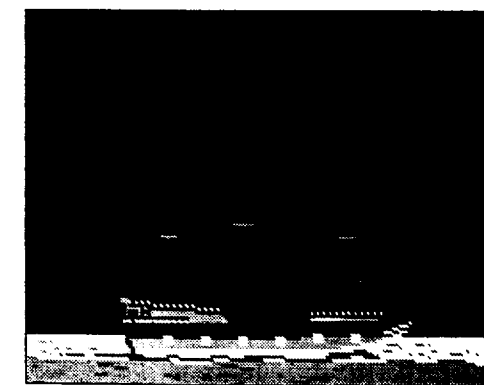

The Skull & Crossbones™ game tests itself and provides visual and audible indications of the condition of the game circuitry and controls. Self-test information is displayed on the screen and through the sound system. No additional equipment is required. We suggest that you perform the self-test when you first set up the game, each time

you collect the money, or when you suspect game failure. The self-test screens provide information about the game circuits and controls. To enter the self-test, turn on the self-test switch located at the front of the JSA Audio II board. To leave the Self-Test, turn off the self-test switch only while displaying the Select Test menu.

Table 2-1 Summary of All Self-Test Screens

Screen	Use or Purpose
Statistics Screen	Displays game statistics.
Histogram Screen 1	Displays the histogram for all new games.
Histogram Screen 2	Displays the histogram for all continued games.
Histogram Screen 3	Displays the histogram for the level at which players quit.
Histogram Screen 4	Histograms on this screen are not usable for operators.
Histogram Screen 5	Histograms on this screen are not usable for operators.
Histogram Screen 6	Histograms on this screen are not usable for operators.
Game Options Screen	Use to set and check the game options settings.
Coin Options Screen	Use to set and check the coin options settings.
Sound Test Screen	Use to check the audio PCB circuits, RAM, and ROM. Also use to check the coin mechanism operation.
Complete RAM Test Screen	Use to test RAM.
Complete ROM Test Screen	Use to test program ROM.
Playfield Test Screen	Use to test the game scrolling circuitry.
Motion Object Screen	Use to test the movement and color of game objects.
Alpha Test Screen	Use to check the alphanumeric displays.
Color Test Screen	Use to check the video display color circuits.
Red Color Purity Screen	Use to check the red color purity in the video display.
Green Color Purity Screen	Use to check the green color purity in the video display.
Blue Color Purity Screen	Use to check the blue color purity in the video display.
White Color Purity Screen	Use to check the white color in the video display.
Grey Color Purity Screen	Use to check the grey color in the video display.
White Convergence Screen	Use to check and adjust video display convergence of red, blue, and green.
Violet Convergence Screen	Use to check and adjust video display convergence of red to blue.
Green Convergence Screen	Use to check and adjust video display convergence of red and blue to green.

Self-Test Selection

The 13 tests in the self-test procedure are listed in a menu, which is displayed immediately after you enter the self-test. To select any of the tests, move the left joystick up or down (you can also press the left Turn button). To start the selected test, press the left player sword button. To leave the self-test, turn off the self-test switch when the menu is displayed. The 13 tests are:

- Statistics and Histograms
- Game Options Test
- Coin Options
- Sound Board Test
- Switch Test
- Complete RAM Test
- Complete ROM Test
- Playfield Test
- Motion Object Test
- Alphanumeric Pfld Test
- Color Test
- Purity Test
- Convergence Test



Statistics and Histogram Screens

Use the information shown on the statistics screen and on the histogram screens to keep track of your game use. Record the information on the Skull & Crossbones statistics page in the back of this manual.

The information shown on the Statistics Screen (see Figure 2-1) is accumulated from the last time the statistics were reset. Simultaneously press the RED DOG SWORD and TURN buttons to reset the statistics.

At the bottom of the statistics screen are two times and dates. These are the program version dates. If you are having problems with your game, you may need to give Atari Games Customer Service this information.

The statistics screen shows the following statistics:

- **Left Coins:** number of coins deposited into the left coin mechanism.
- **Right Coins:** number of coins deposited into the right coin mechanism.
- **New Players:** number of players beginning a new game.



Figure 2-1 Statistics Screen

- **Bonus coins:** number of extra coins that players have accrued before entering the game.
- **0 Plyr Minutes:** number of minutes of non-use.
- **1 Plyr Minutes:** number of minutes of 1-player use.
- **2 Plyr Minutes:** number of minutes of 2-player use.
- **L Plyr Minutes:** number of minutes of left-side use.
- **R Plyr Minutes:** number of minutes of right-side use.
- **Sessions:** shows the total number of games played since the last time the statistics were cleared.
- **Error Count:** shows the number of errors counted in the erasable memory. If you have a count of more than 75, you should have your game serviced by a qualified service technician.
- **Total Coins:** accumulation of coins from the left and right coin mechanisms.
- **1 Player Coins:** number of coins used in the 1-player mode.
- **2 Player Coins:** number of coins used in the 2-player mode.
- **Average Time per Coin:** time divided by the total number of coins deposited.
- **Average 1P Time/coin:** 1-player minutes divided by the 1-player coins deposited
- **Average 2P Time/coin:** 2-player minutes divided by the 2-player coins deposited

Histograms

The first of the three usable histogram screens is shown in Figure 2-2. The three histogram screens display the following information:

- Histogram 1 shows the time in seconds of all first coins deposited.

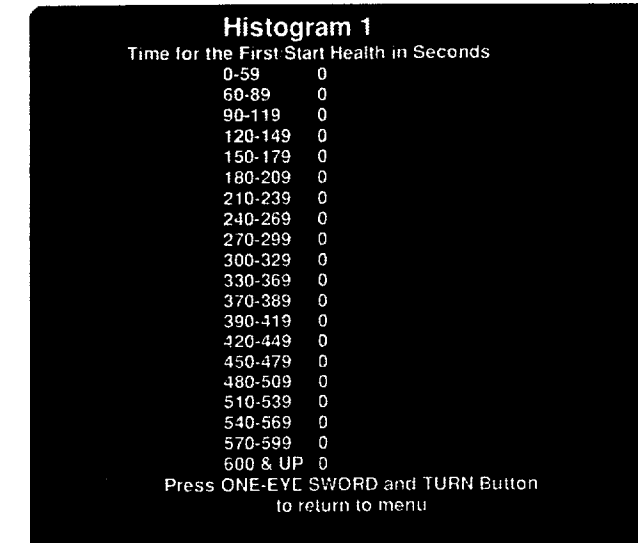

Figure 2-2 Histogram 1 Screen

- Histogram 2 shows the time in seconds of all additional coins deposited.
- Histogram 3 shows at which waves the players did not continue.
- Histograms 4, 5, and 6 are for development use only, and contain no operator-adjustable information.

If you read the screens infrequently, the number of games will always be correct proportionally, but may be incorrect numerically.

Game Options

To move through the game options, including the ones before the word *MORE*, push the left joystick up or down. You can change the highlighted game option. The factory default settings are shown in green. To change an option setting, move the left joystick right or left.

NOTE

Not all of the options are shown when you enter this screen. The word *MORE* shows at the top or bottom of the screen to indicate more options. Use the left joystick to scroll through the options.

- **Sounds in Attract (Mode)?** plays the Skull & Crossbones game music, if set to *yes*.
- **Reset High Score Table?** clears the high score table, if set to *yes*.

- *Game Difficulty?* adjusts the speed of the enemies that players must fight during each wave.
- *Health at Start?* controls the amount of health given at the start of the game.
- *Health for Additional Coins?* controls the amount of health given for inserting additional coins.
- *Bonus Health (for) Coins Added Before Start?* controls whether you give progressively larger amounts of health to players who insert additional coins before entering the game.
- *The Low Health Warning?* option is a type of censor to eliminate the blood spurt warning to players that their health is about to run out.

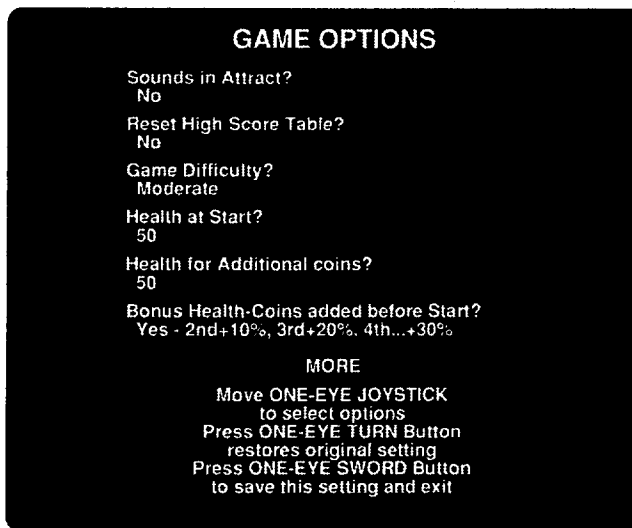

Figure 2-3 Game Options Screen

- *Coins Mechs?* can allow all the coins to be pooled, and players must then assign the coins to each other by pressing one of the two auxiliary coin switches. Refer to Chapter 1 for more information.
- *Restore Factory Default?* allows you to set all the game options to the factory-recommended options by choosing *yes*. If you want to use your own settings, be sure to set this to *no*.

The Game Option Screen can be seen in Figure 2-3 above.

Coin Options

To move through the coin options, push the left joystick up or down. You can change the highlighted coin option. The factory default settings are shown in green. To change an option setting, move the left joystick right or left.

- *Coins to Start a New Player* is the number of coins required for a new player to enter the game.

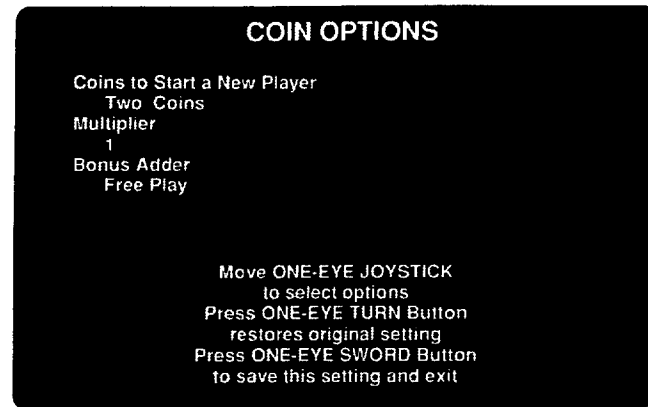

Figure 2-4 Coin Options Screen

- *Multiplier* is the value of each coin inserted in the coin mechanisms. For example, if you select 2, then each coin counts as two coins.
- *Bonus Adder* lets you choose bonus coins, no bonus, or free play.

Sound Board Test

The sound test indicates the condition of the music and sound effects circuits on the JSA Audio II Board. The sound test screen is shown in Figure 2-5. The



Figure 2-5 Sound Board Test Screen

sound microprocessor resets at the beginning of the test. You will hear the first sound three seconds after the test starts.

After the microprocessor is reset and you hear the first sound, the number of the game sounds and the sound CPU status appear information. If the CPU is good, the word "Good" appears. If you get an error message at any point in the sound test, see Table 2-3 for more information.

The test cycles through the following tests:

- Music Chip Test
- ADPCM Test
- SCOM Reset Test

Switch Test

The switch test is shown in Figure 2-6. Use this test to check the controls. As you press the buttons and move the joysticks, the proper lines should light up.

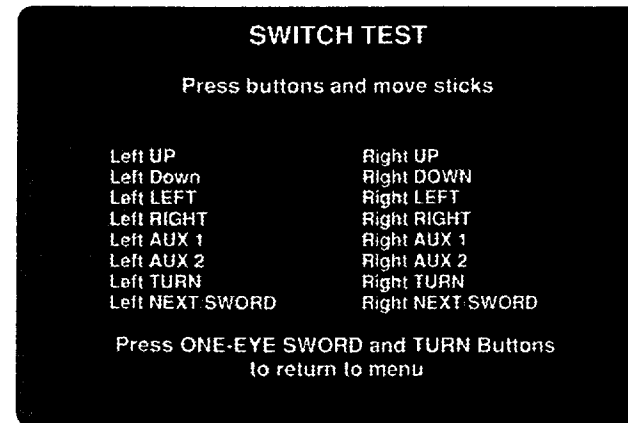

Figure 2-6 Switch Test Screen

If the highlighting does not appear, follow the maintenance and repair procedures for the controls in Chapter 3 of this manual. Press the left player SWORD and TURN buttons together to move to the next screen.

Complete RAM Test

While this test is checking the RAMs, you see a white screen. If the game successfully completes the RAM

test, the menu will reappear in less than 15 seconds. If the game has a bad RAM, you may see a message (see Figure 2-7 for an example) or, if the problem is severe, you may only see a colored screen.

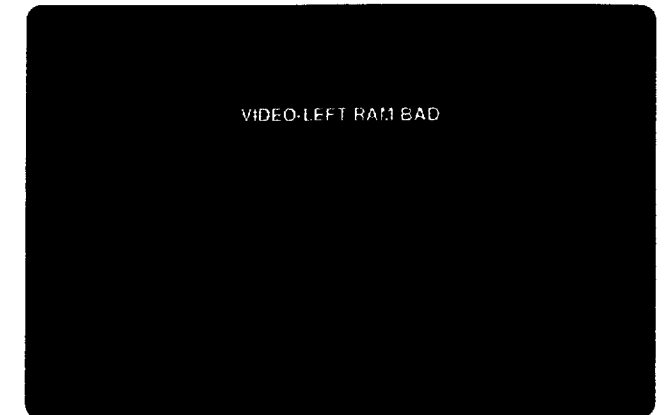

Figure 2-7 RAM Error Message

Complete ROM Test

If the game has an error in the program ROMs, then the error number is shown on the ROM test screen within two seconds. The characters in parentheses denote the chip locations on the game PCB. See Figure 2-8 for an example of an error display.



Table 2-2 Game Option Settings

Option	Available Settings			
Sounds in Attract	Yes ♦	No		
Reset High Score Table	No ♦	Yes		
Game Difficulty	Easy	Moderate ♦	Hard	Hardest
Health at Start	25, 50 ♦, 60, 80, 100, 150, 200, 250			
Health for Add'l Coins	10, 20, 30, 40, 50 ♦, 60, 80, 100			
Bonus Health for Coins Added Before Start?	None		Yes—2nd is +10%, 3rd is +20%, and 4th or more coins are +30% ♦	
Low Health Warning?	Nothing		Blood Spurt ♦	
Coin Mechs?	Separate mechs ♦		Pooled mechs—need extra buttons	
Restore Factory Default	Yes		No ♦	
♦ Manufacturer's recommended settings				

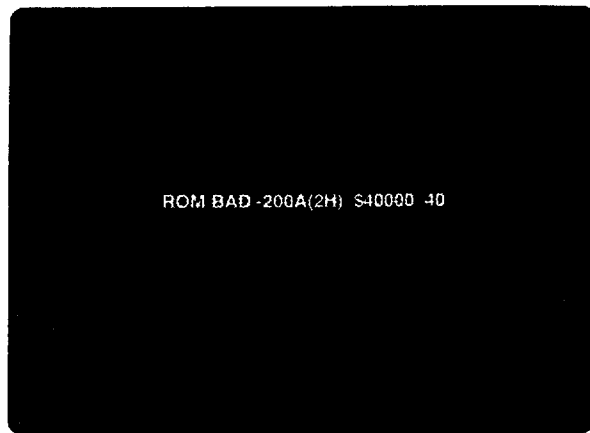

Figure 2-8 ROM Error Message



Figure 2-9 Playfield Test Screen

Playfield Test

This test indicates the condition of some of the graphics ROMs, the vertical and horizontal scroll registers, and the joystick control. Use the left joystick to move left, right, up, and down. Press the left TURN button to see all the playfield palettes, numbered 0 to 15. The screen is shown in Figure 2-9. Exit the screen by pressing the left sword button.

Motion Object Test

The motion object test screen is shown in Figure 2-10. This tests the movement and color of various game objects.

Choose an object with the left sword button. Use the left joystick to move the object. Press the left jump button to move to the next object.

Exit the screen by pressing the left SWORD and TURN buttons.

Alphanumeric Pfld Test

The alphanumeric test checks the condition of the alphanumeric in the game. If you see stripes or broken-up characters, then the chip at 250K on the game PCB is probably bad.

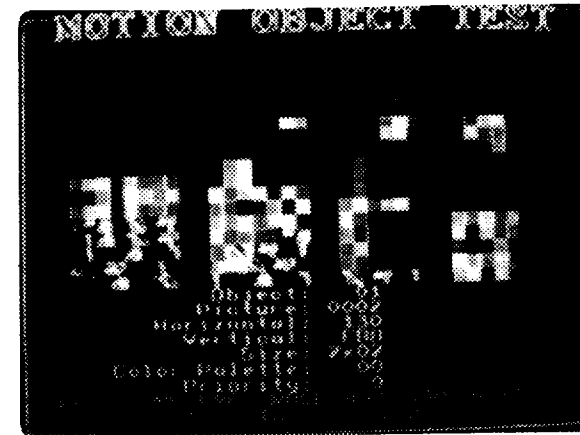

Figure 2-10 Motion Object Test Screen



Figure 2-11 Alphanumeric Test

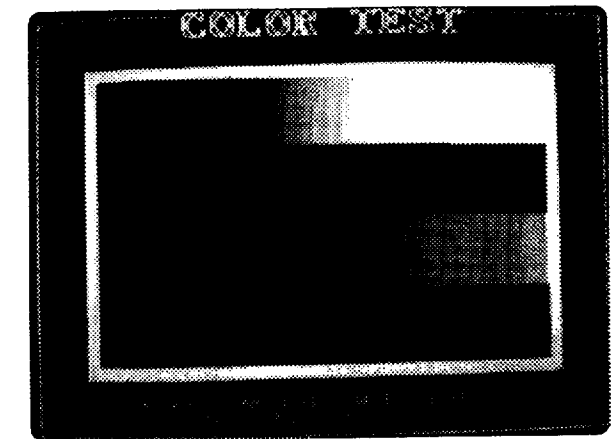

Figure 2-12 Color Test

and no lines in the display. The screens are red, green, blue, white, and gray.

If the screens are not correct, see the video display manual included with the game for adjustments.

Exit each screen by pressing any left TURN button.

Convergence Test

The convergence test is shown in Figure 2-14. This test has three screens. The first is white, the second is purple, and the last is green.

Check the following on the screens:

- The grid lines should be straight within 3.0 mm and the lines should not pincushion or barrel.
- The convergence of the lines on the violet and white screens should be within 2.0 mm.

Table 2-3 Faulty Sound RAM and ROM Locations

Error Message	Location on JSA Audio II PCB	Cause or Comment
Music Chip Time Out	3A	
Sound CPU Interrupt Error	5F, 5K, 4K	
Sound CPU RAM 1 Error	2B	
Sound CPU ROM 1 Error	1B	If you see this when you enter the sound test, the sound processor cannot proceed any further. Press any right player button to exit the test.
Communications Error #1	3D	Counts the number of errors caused by the JSA II PCB or Game PCB. This means that the SCOM chip (part no. 137526-001) on one of these boards is bad.
<p>CAUTION <i>The SCOM chip is a CMOS IC and is static-sensitive. If you do not handle it properly, you can permanently damage this chip.</i></p>		
Communications Error #2		Probably the JSA Audio II PCB is disconnected from the Game PCB, or the chip at 1D is not inserted into its socket.
Sound Processor Not Responding		A major problem with the JSA Audio II PCB. If you cannot enter the self-test, check that the connector between the JSA Audio II PCB and the Game PCB is plugged in properly.

Color Test

This test indicates the condition of the video display color circuits. The screen is shown in Figure 2-12.

The left side of the screen should be black and change to light colors on the right. From top to bottom the screen should appear white, red, green, and blue.

If the screen does not fit this description, refer to the manual for your video display. Exit the screen by pressing left sword button.

Color Purity Test

The color purity test has five screens. The first screen is shown in Figure 2-13.

These screens show the condition of the color purity circuit in the video display. Each screen should display a rectangle of color, with no curving at the corners

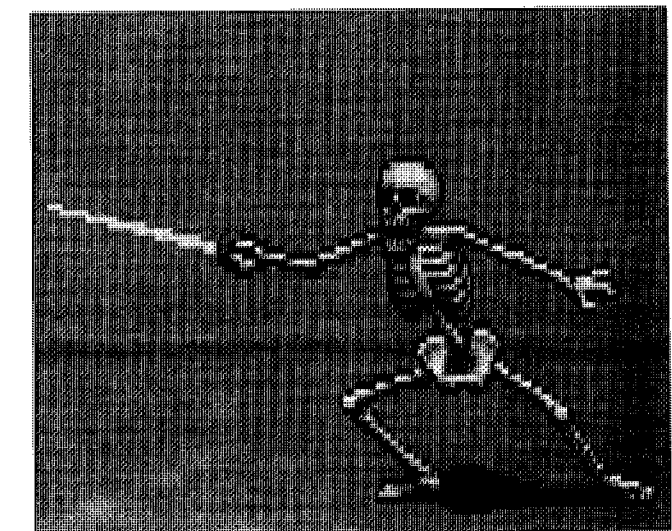

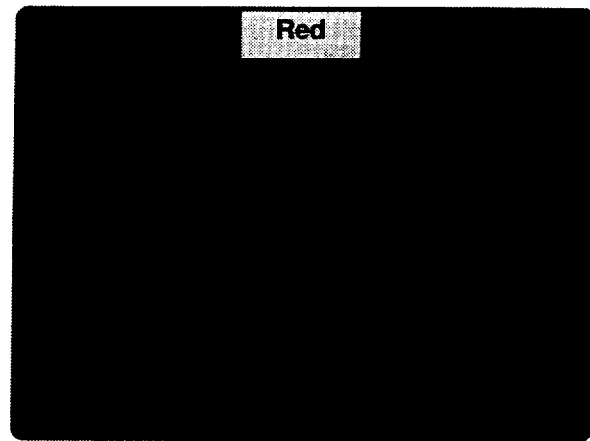

Figure 2-13 Color Purity Test

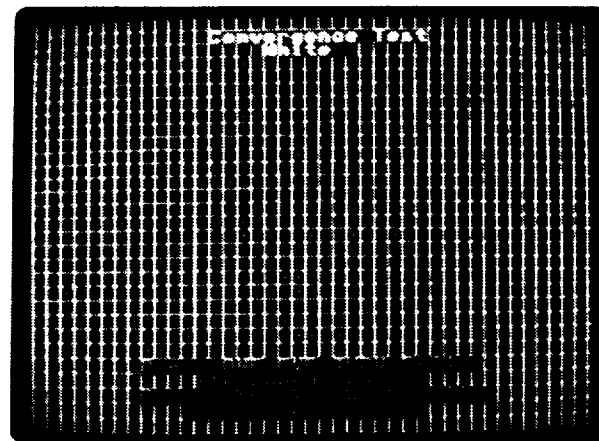
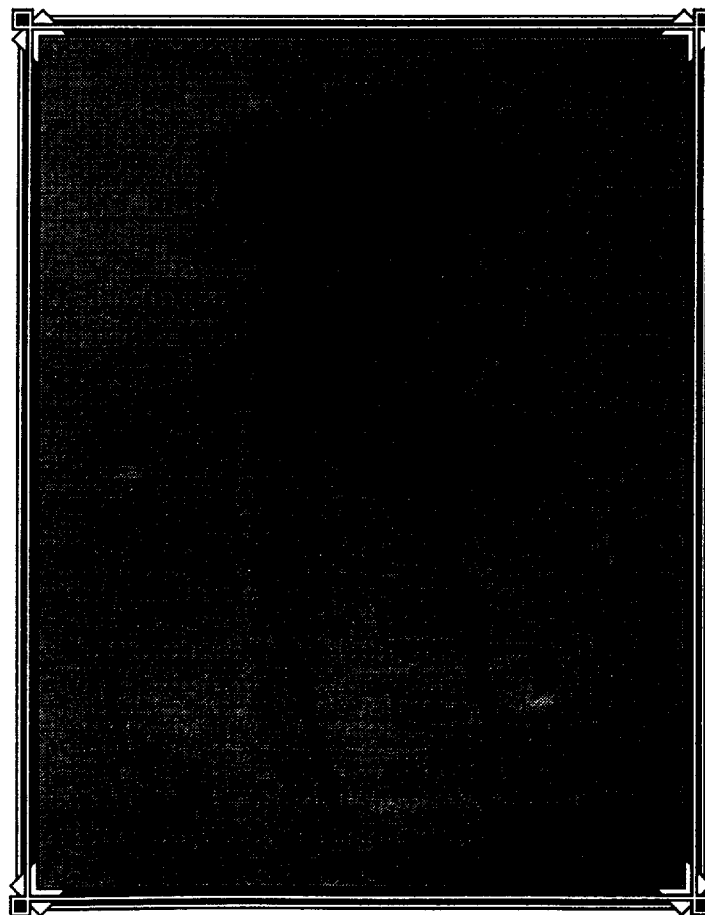
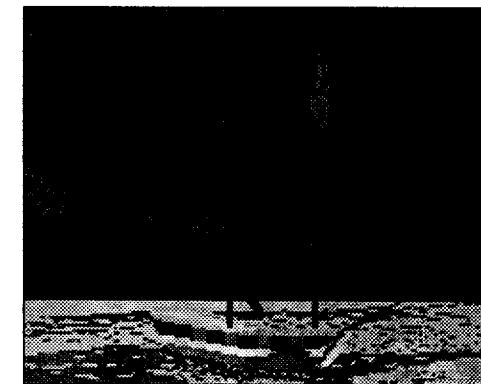

Figure 2-14 Convergence Test



Chapter 3

Maintenance and Troubleshooting



This chapter contains regular maintenance information, troubleshooting tables, and repair procedures for your Skull & Crossbones game. This chapter contains the regular preventive maintenance schedule and information on maintaining the joystick. The next part contains three troubleshooting tables. One table has general troubleshooting information, the second contains the volt-

age levels and test points on the PCBs, and the last is a table of ROM-caused problems with specific ROMs to check and replace.

The last part of the chapter contains repair procedures and removal instructions for the joystick, video display, and speakers of the Skull & Crossbones game. If a part is mentioned, but not illustrated, see Chapter 4, *Illustrated Parts Lists*, for information.

Preventive Maintenance

Preventive maintenance includes inspecting, cleaning, lubricating, and tightening hardware. Perform the preventive maintenance regularly so you can keep the game in top condition, avoid problems, and maximize your earnings. Preventive maintenance tasks and intervals are shown in Table 3-1.

For the best performance from your Skull & Crossbones game, you should check and maintain your game according to the times shown in Table 3-1. The preventive maintenance procedures for the joystick and coin mechanism are in this section.

WARNING

Always unplug the game before you perform any repairs.

Maintaining the Joystick

Maintain the joystick by inspecting the pivot ball, actuator half-ball, and the shaft and by lubricating the joystick with lithium grease.

1. Turn off the power to the game.
2. Open the control panel and disconnect the harness connector.
3. Remove the joystick from the control panel. Use a 3/8-inch wrench to remove the nuts and washers that hold the joystick on the control panel.
4. Remove the four long screws that hold the joystick together. See Figure 3-1.
5. Take off the 8-position plate, the actuator, and the lower housing.
6. Check the actuator half-ball, the pivot ball, and the shaft for dirt and wear.
7. Lubricate the actuator half-ball on the end of the joystick shaft, the pivot ball below the upper housing, and the spring inside the upper housing. Use lithium grease.
8. Put the joystick assembly back together. Fit the pin in the pivot ball into the slot in the lower housing.

Table 3-1 Maintenance and Inspection Items

Part	When to Check	What to Check and Maintain
Coin Mechanism	Every 6 months	Clean.
Interior Components	Every 3 months	Clean.
Joystick	Every 3 months	Lubricate. Make sure nuts holding the joysticks on the control panel are tight.
PushButtons	Every 6 months	Make sure the pushbuttons are tight on the control panel.

9. Replace the long screws and tighten them. Do not over-tighten the screws. The joystick handle must return to center easily.

NOTE

Do not over-tighten the long screw. Over-tightening can cause difficulty in moving the handle and frustration for players.

10. Replace the joystick assembly on the control panel.
11. Use the self-test to make sure you have reassembled the joystick correctly. dust and dirt out with compressed air.

Troubleshooting

The tables in this section (3-2, 3-3, and 3-4) can help you troubleshoot problems in your game. The troubleshooting table lists possible sources of problems of various parts of the game. The voltage inputs and test points can help you troubleshoot PCB problems. The ROM problems table can help determine exactly which ROM might be causing game play problems.

Repairs

This section includes the procedure for repairing the joystick assembly.

Disassembling the Joystick

Perform the following procedure to disassemble the joystick (see Figure 3-1).

1. Take off the control panel and disconnect the harness connectors.
2. Remove the joystick from the control panel. Use a 3/8-inch wrench to remove the four locknuts and washers holding the joystick onto the control panel.
3. Remove the four screws holding the 8-position plate on the bottom of the assembly.
4. Remove the white plastic actuator and the lower housing that the four switches are attached to.
5. Remove the small roll pin holding the actuator half-

ball on the bottom of the shaft by pushing the roll pin all the way through the shaft. Slide the actuator half-ball off the end of the shaft.

6. Remove the large roll pin holding the large pivot ball on the shaft below the upper housing. Push the pin through the ball and the shaft. The pin will not be easy to remove because of the pressure on the pivot ball from the spring above it. After you push the pin all the way through the ball, slide the pivot ball off the shaft.
7. Slide the upper housing off the shaft.
8. Slide the plunger and the spring off the shaft.
9. Slide the disc off the shaft.

Reassembling the Joystick

1. Install the disc on the shaft.
2. Slide the spring on the shaft. Push the large end of plunger onto the shaft and over part of the spring (see Figure 3-1).

NOTE

Lubricate the plunger, ball, and housing at this point in the reassembly procedure.

3. Slide the upper housing onto the shaft.
4. Before you put the pivot ball on the shaft, insert the large roll pin partway into the pivot ball. The roll pin should not interfere with sliding the pivot ball onto the shaft. Slide the ball onto the shaft, and line up the roll pin with the hole in the shaft. Now push the pin through the shaft.
You will have to hold the pivot ball against the pressure of the spring. Make sure the ends of the roll pin extend out the same amount on both sides.
5. Put the small roll pin part way into the actuator ball and slide the ball onto the shaft. Line up the roll pin with the shaft hole. Push the roll pin

through the ball and the shaft.

6. Fit the lower housing over the shaft so that the ends of the large roll pin fit into the slots on the inside of the housing. Turn the lower housing so that screw casings align with the holes in the upper housing.
7. Put on the white plastic actuator so that the black cushion ring is opposite the switches.
8. Now install the 8-position plate below the actuator so that you can reinsert the long screws.
9. Put the long Phillips head screws through the 8-position plate and up through the housings. Do not over-tighten the screws, or the joystick will be too hard to move.

NOTE

The joystick handle must return freely to the center position. If it does not, players are likely to become frustrated with the game.

10. Reinstall the joystick on the control panel.

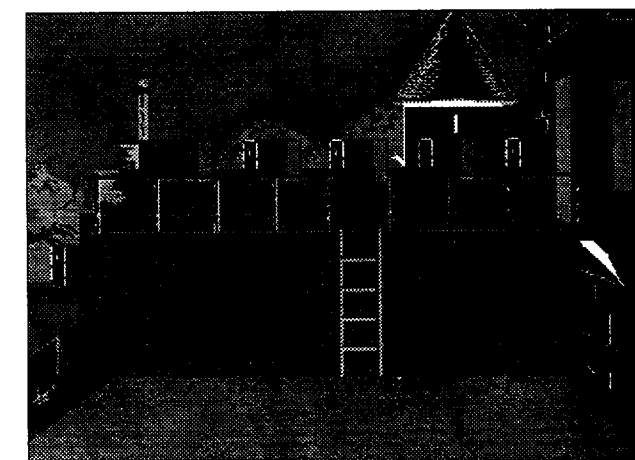

Table 3-2 Voltage Inputs and Test Points on the PCBs

PCB	Voltage	Test Point or LED	Source and Purpose
Main	+5 ± 0.25 VDC	VCC1	Logic power from the switching power supply.
Main		CR1 LED	Lights when 5 V is applied to the main PCB and the reset (RST) jumper is open.
Audio		CR4 LED	Lights when the -5 V supply is good.
Audio		CR3 LED	Lights when the +5 V supply is good.
Audio		CR5 LED	Lights when the +12 V supply is good (but only if the audio PCB has a 12 V resistor at Q3 on it).

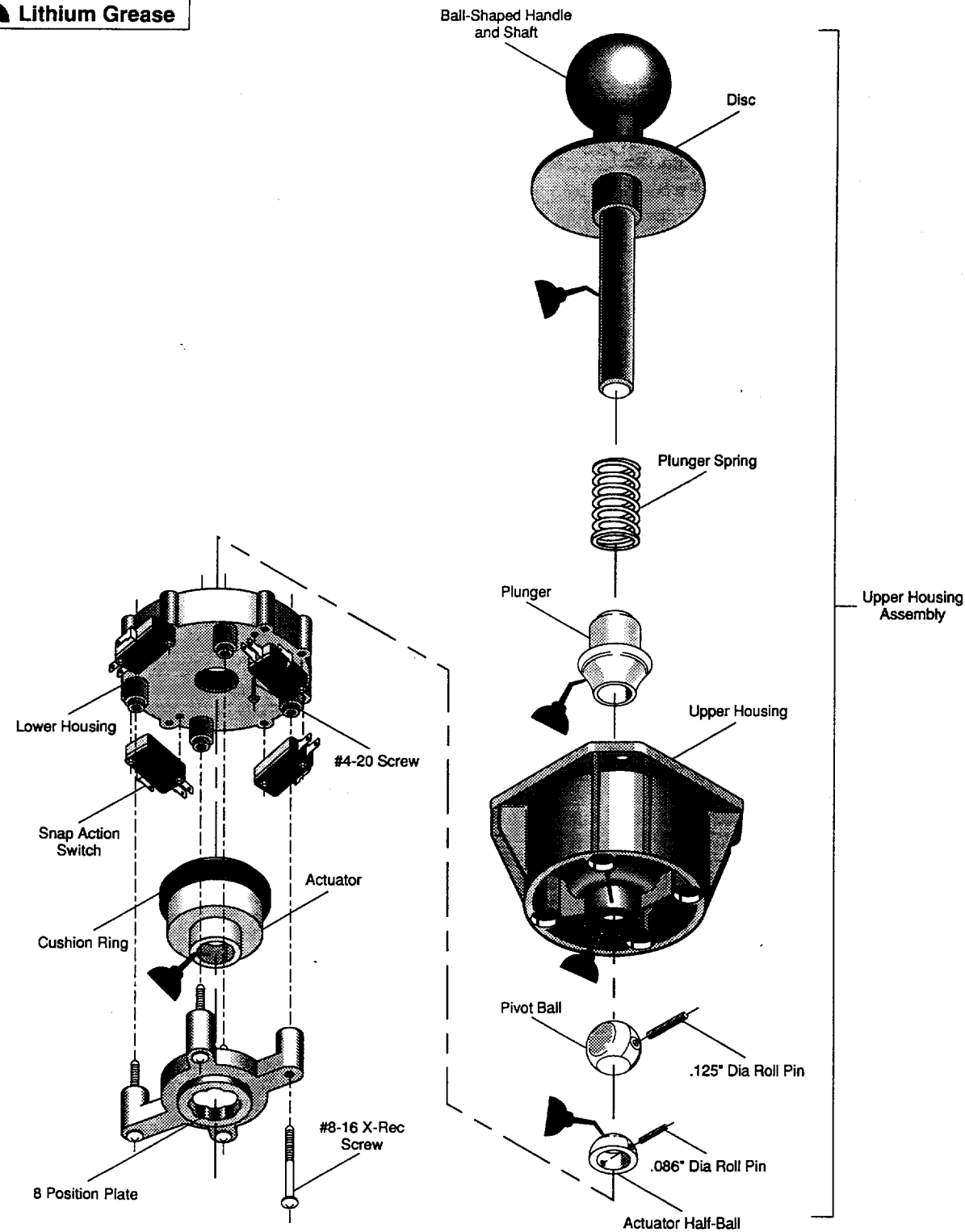

Figure 3-1 Maintaining the Joystick

Table 3-3 Troubleshooting Table

Problem	Suggested Action
Coin Mechanism Problems	Test the coin mechanisms with the sound test screen in the self-test.
Game Play Problems	<ol style="list-style-type: none"> 1. Check the harness and connectors. 2. Perform the self-test. 3. Check the voltage levels on the PCBs. See Table 3-2, <i>Voltage Inputs and Test Points</i>. 4. Check <i>What ROM Problems Look Like</i>, Table 3-4, for specific ROM problems.
A screen character does not move or moves intermittently.	Check the connections.
Joystick Problems	<ol style="list-style-type: none"> 1. Has the joystick been lubricated with white lithium grease? If not, lubricate it. 2. Check the harness and connectors. 3. If you took the joystick apart, have you reassembled it correctly? 4. Make sure all the parts on the joystick are in good repair. Repair or replace parts.
The handle does not immediately return to center.	<ol style="list-style-type: none"> 1. Make sure the actuator is installed correctly. 2. Lubricate the joystick.
A joystick handle sticks.	<ol style="list-style-type: none"> 1. Check if the screws holding the joystick assembly together are too tight. 2. Lubricate the assembly.
Sound Problems	<ol style="list-style-type: none"> 1. Is the speaker volume turned up? 2. Check the audio ROM and RAM in the self-test on the Sound Test screen. See Table 2-4, <i>Bad Sound RAM and ROM Locations</i>. 3. Check the voltage level to the audio PCB. See Table 3-2, <i>Voltage Inputs and Test Points</i>. 4. Check the wiring from the audio PCB to the speaker. 5. Replace the speaker.
Video Display Problems	
Screen is dark	<ol style="list-style-type: none"> 1. Is the game plugged in? 2. Is the game turned on? 3. Are the connections good? 4. Check all of the items below. If you can answer <i>no</i> to any question, you have a problem with the video display. See your video display service manual. <ol style="list-style-type: none"> a. Do you have power to the video display? b. Are the video display's filaments lit? c. Do you have high voltage to the video display? 5. Is the voltage level to the video display PCB correct? (Power voltage is 100 VAC or 110 VAC, depending on the type of video display. Video signal voltage is 0.5 to 3.5 Volts.) 6. If the level is not correct, check the connectors and the harness. 7. Check the +12 V and the +10 V circuit on game PCB.
Display area wavers or is too small	<ol style="list-style-type: none"> 1. Check the voltage to the video display PCB. 2. Do you have high voltage to the video display?
Convergence, purity or color problems	Use the screens in the self-test to adjust the video display.
Game is stuck in self-test	Make sure both self-test switches are switched off. If one or both are switched on, then the game will be in self-test.

Table 3-4 What ROM Problems Look Like

Problem	ROM Causing Problem	Check the ROM(s) at:
Program works but letters and numbers appear wrong.	Alphanumeric	250K
Program works and the playfield looks OK, but the motion objects are wrong.	Motion object	13P, 13R, 28P, 28R, 41R, 53P, 53R, 67P, 67R, 81R, 95P, 95R, 109P, 109R, 123R, 137P, 137R, 151P, 151R, 165R, 123N, 137N, 151N
Program works, motion objects look OK, but the playfield is wrong.	Playfield	180P, 180R, 193P, 193R, 208P, 208R, 221P, 221R, 235P, 235R
Garbage on screen; program doesn't work.	Video processor	245A, B, C, D
Game program is erratic.	Video program ROM 0, 1, 2, 3, 4, 5, 6, 7	228A, 228C, 213A, 213C, 200A, 200C, 185A, 185C
No sound or erratic sound.	Audio ROM	1B on the JSA Audio II PCB

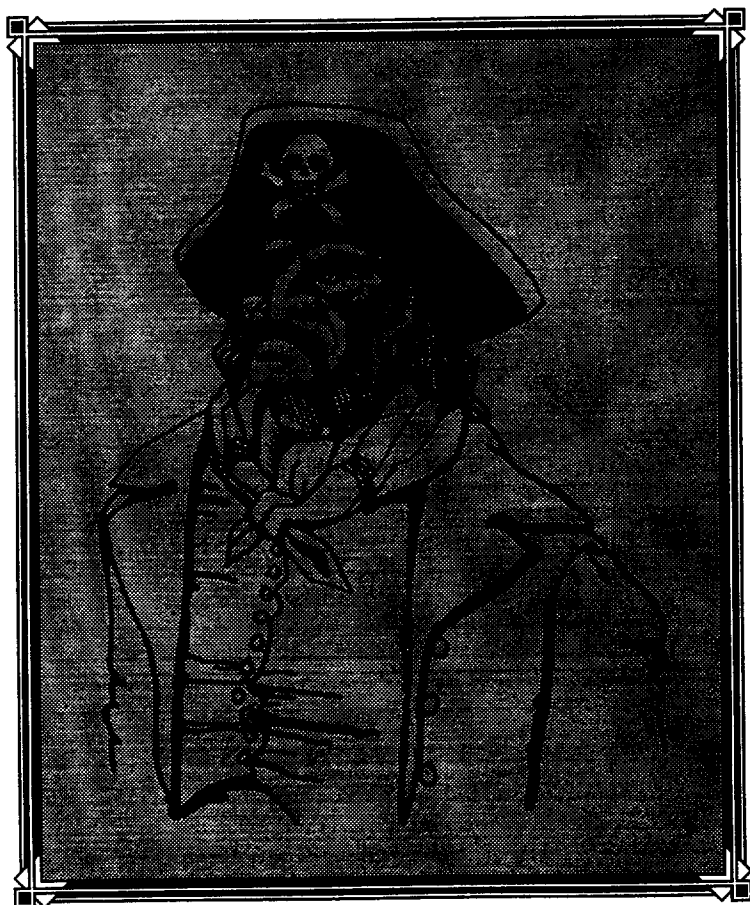

Chapter 4

Illustrated Parts Lists

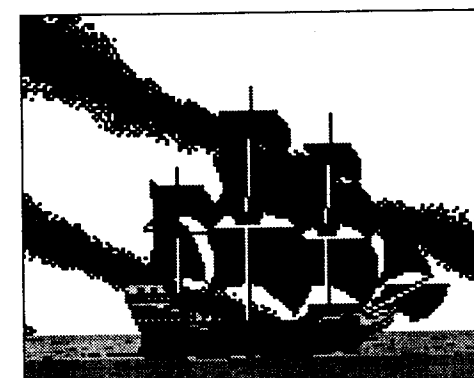

This chapter provides information you need to order parts for your game. Common hardware parts, such as screws, nuts, washers, and so on usually are not listed in the parts lists. The parts lists (except for the PCB parts lists) are arranged alphanumerically by Atari part number. All "A" prefix numbers, which are assemblies, come first. Next are part numbers with six numbers followed by a hyphen (000598- through 201000-). Ending the list are part numbers with a two-number designation followed by a hyphen

(00- through 99-). The PCB parts lists are arranged in alphabetical order by component. Within each section the parts are arranged numerically by part number. When

you order parts, give the part number, part name, the number of this manual, and the serial number of your kit. With this information, we can fill your order rapidly and correctly. We hope this will create less downtime and more profit from your games. Atari Games Customer Service phone numbers are listed on the inside front cover of this manual.

Figure 4-1 Skull & Crossbones Kit Assembly A047450-01 B

Parts List

Part No.	Description	Part No.	Description
047052-01	Left Coin Decal	177010-240	#10-24 Poly Locknut
047052-01	Right Coin Decal	178237-001	Red Button Assembly
047053-01	Side Panel Decal	178237-005	Blue Button Assembly
047205-01	Attraction Shield	178265-001	L-Style Nylon Standoff
		72-6612S	#6 x 3/4-Inch-Long, Type AB, Cross-Recessed Screw
047209-01	Control Panel Cover	75-5116B	#10-24 x 1-Inch-Long Black Carriage Bolt
047451-01	Display Bezel with Graphics	A040933-03	8-Position Microswitch Joystick
047452-01	Attraction Film with Graphics	A046501-01	JAMMA Harness Assembly
047453-01	Control Panel Decal	A046903-01	Skull & Crossbones Game PCB Assembly
047454-01	Set of Control Functions Labels	A047184-02	JSA Audio II PCB Assembly
160044-001	Snap-Action Microswitch with Gold Contacts		

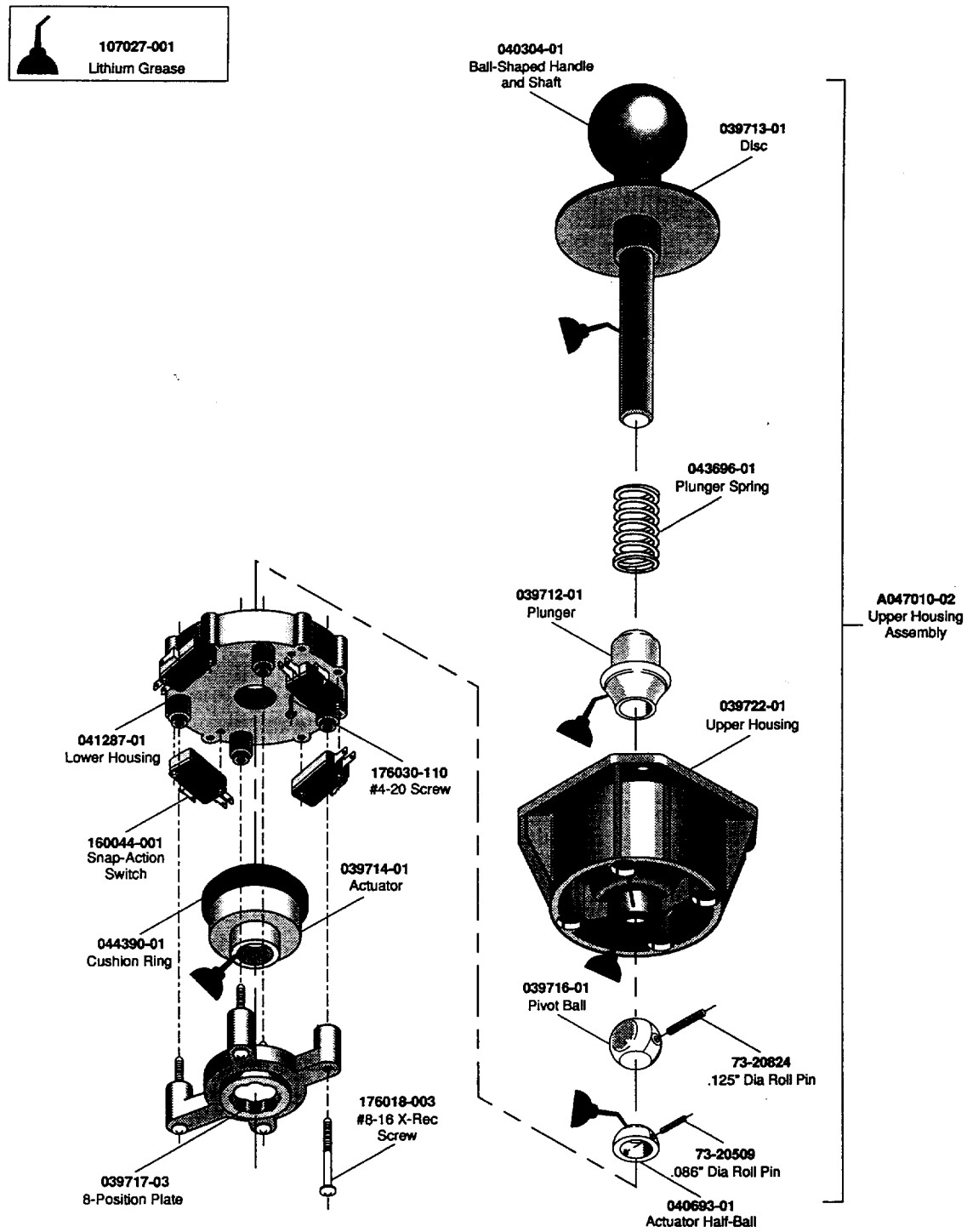

Figure 4-2 Microswitch Joystick Assembly
A040933-03 B

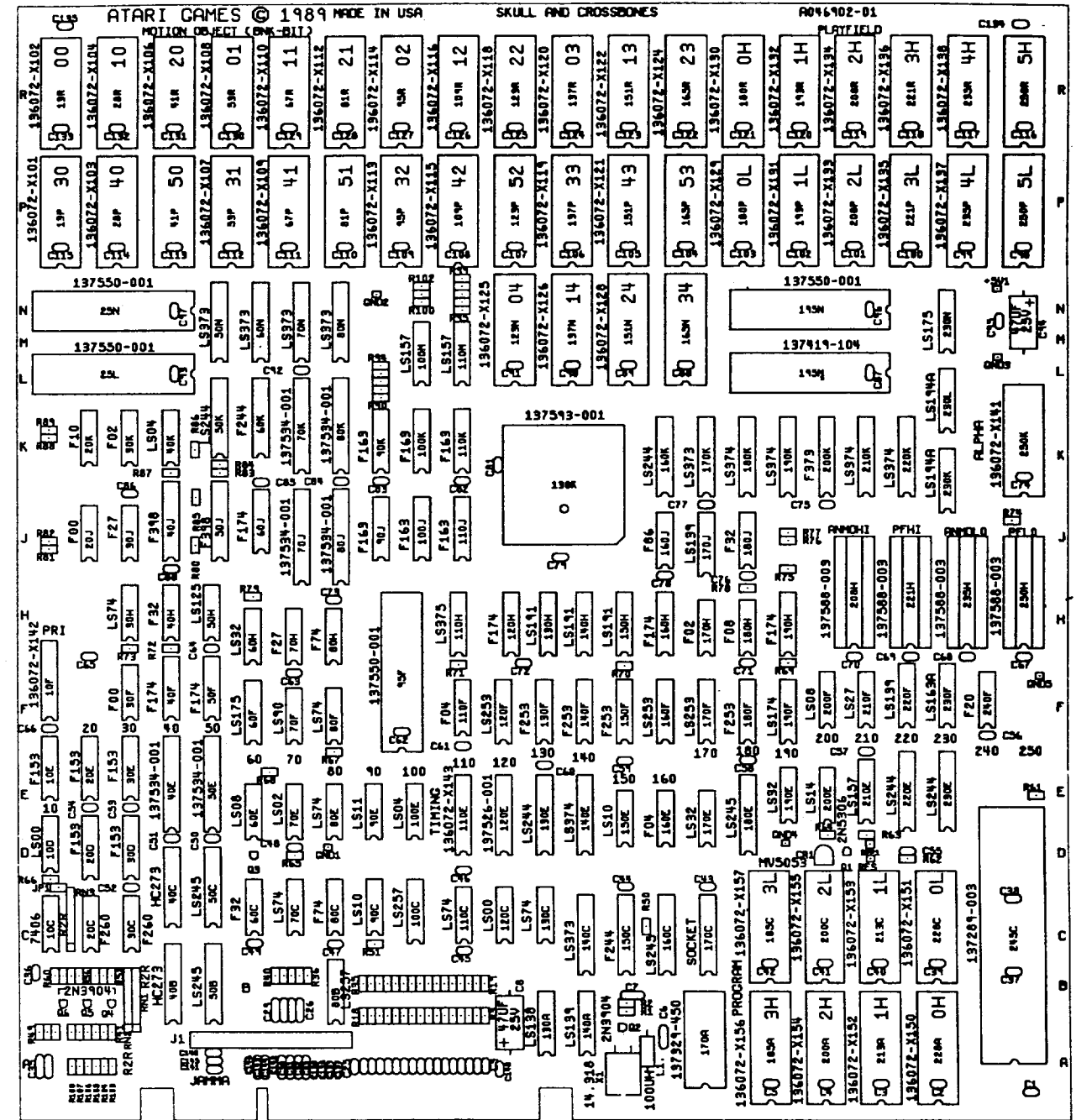

Figure 4-3 Skull & Crossbones Game PCB Assembly
A046903-01 F

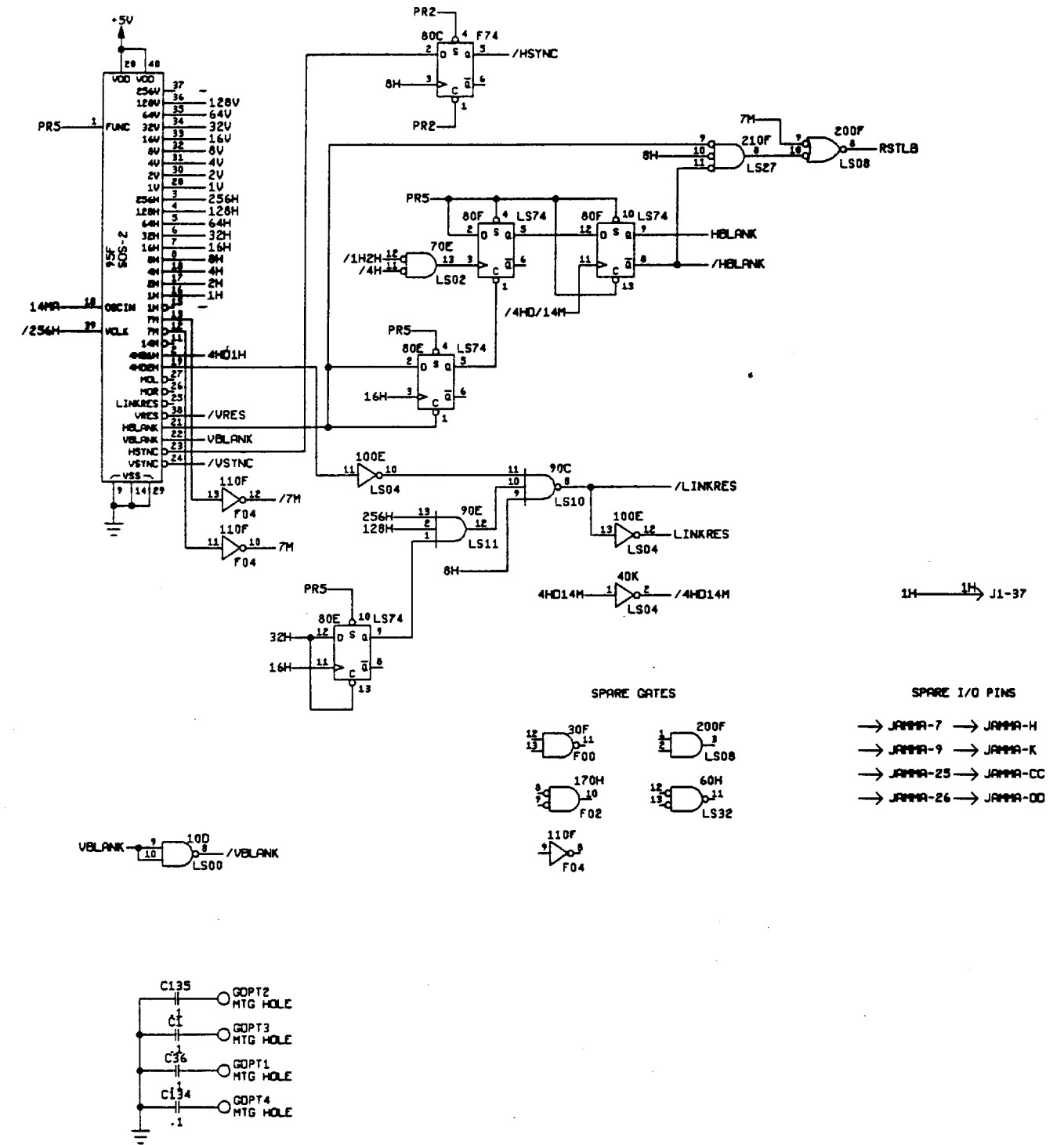
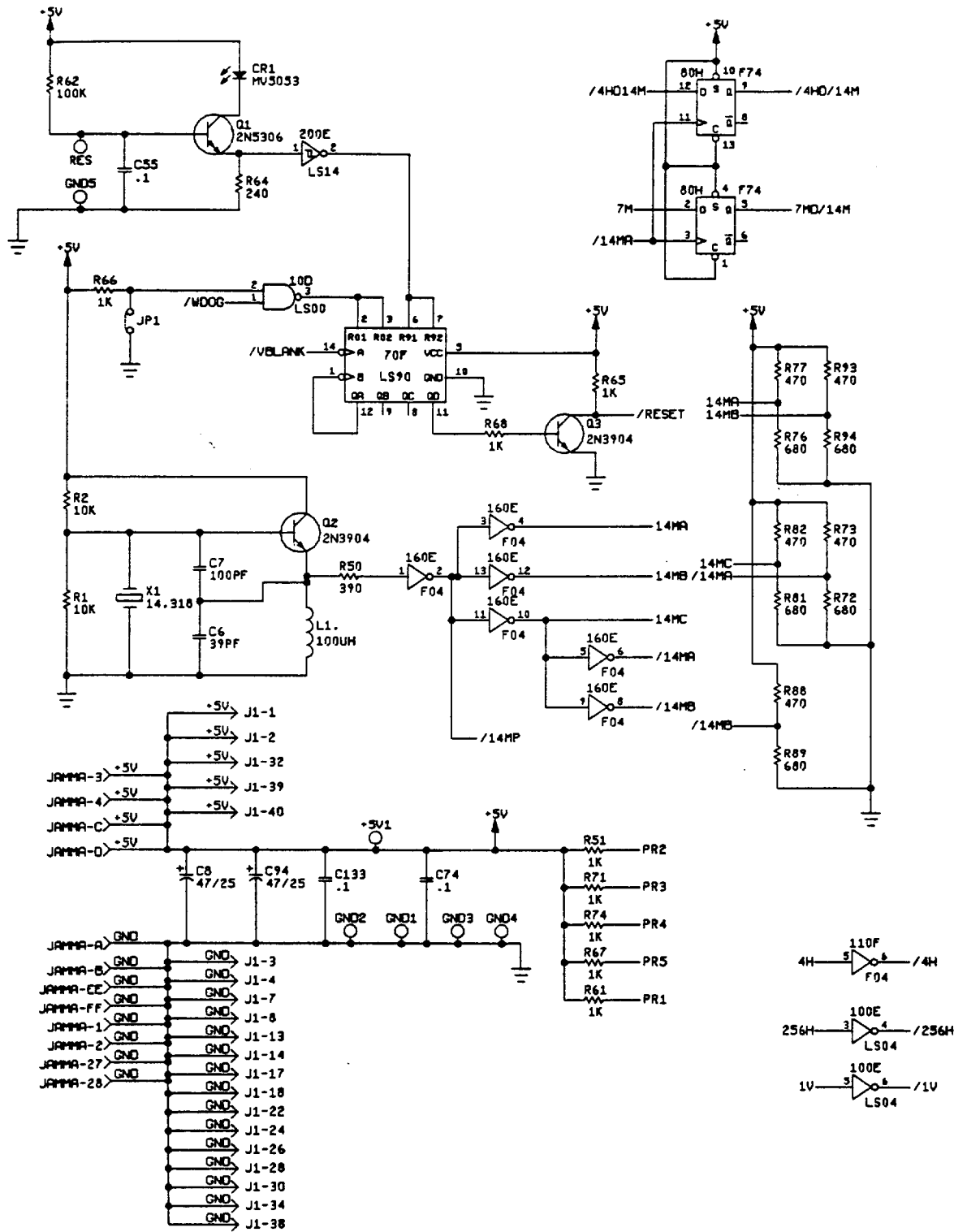

Figure 5-1 Skull & Crossbones Game PCB Assembly Schematic Diagram, Sheet 1 of 10
046903-01 D

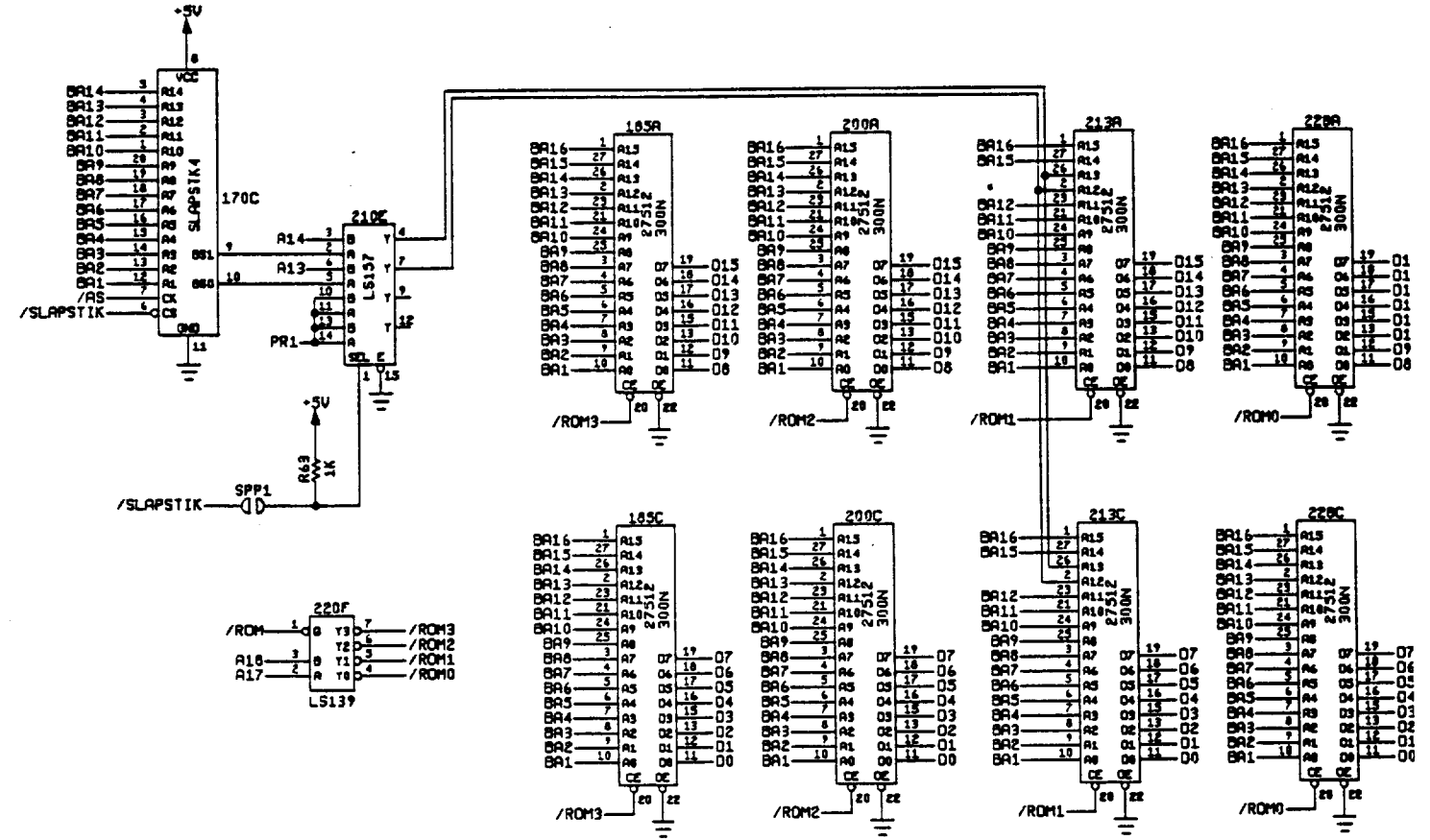
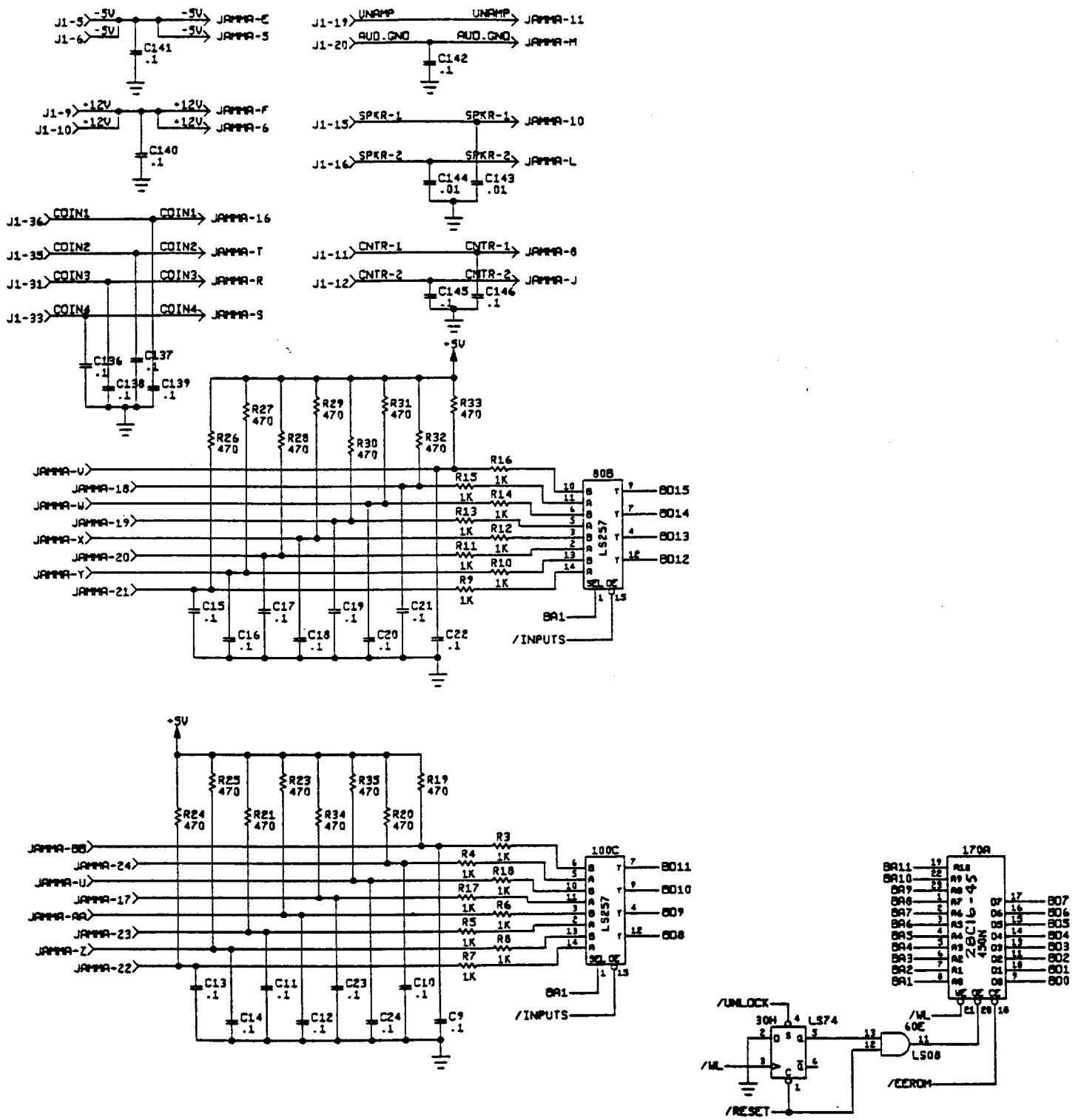

Figure 5-1 Skull & Crossbones Game PCB Assembly Schematic Diagram, Sheet 3 of 10

046903-01 D

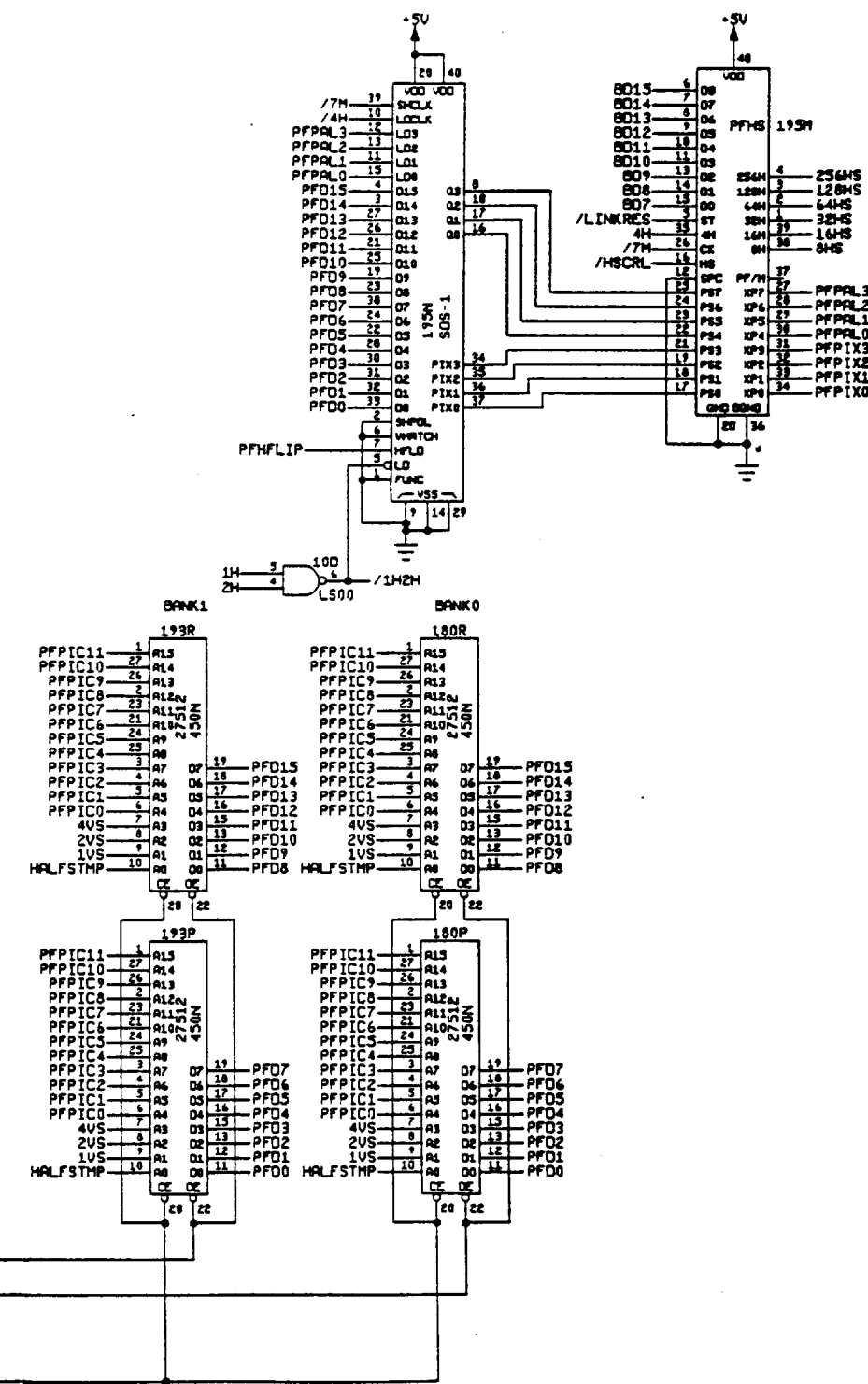
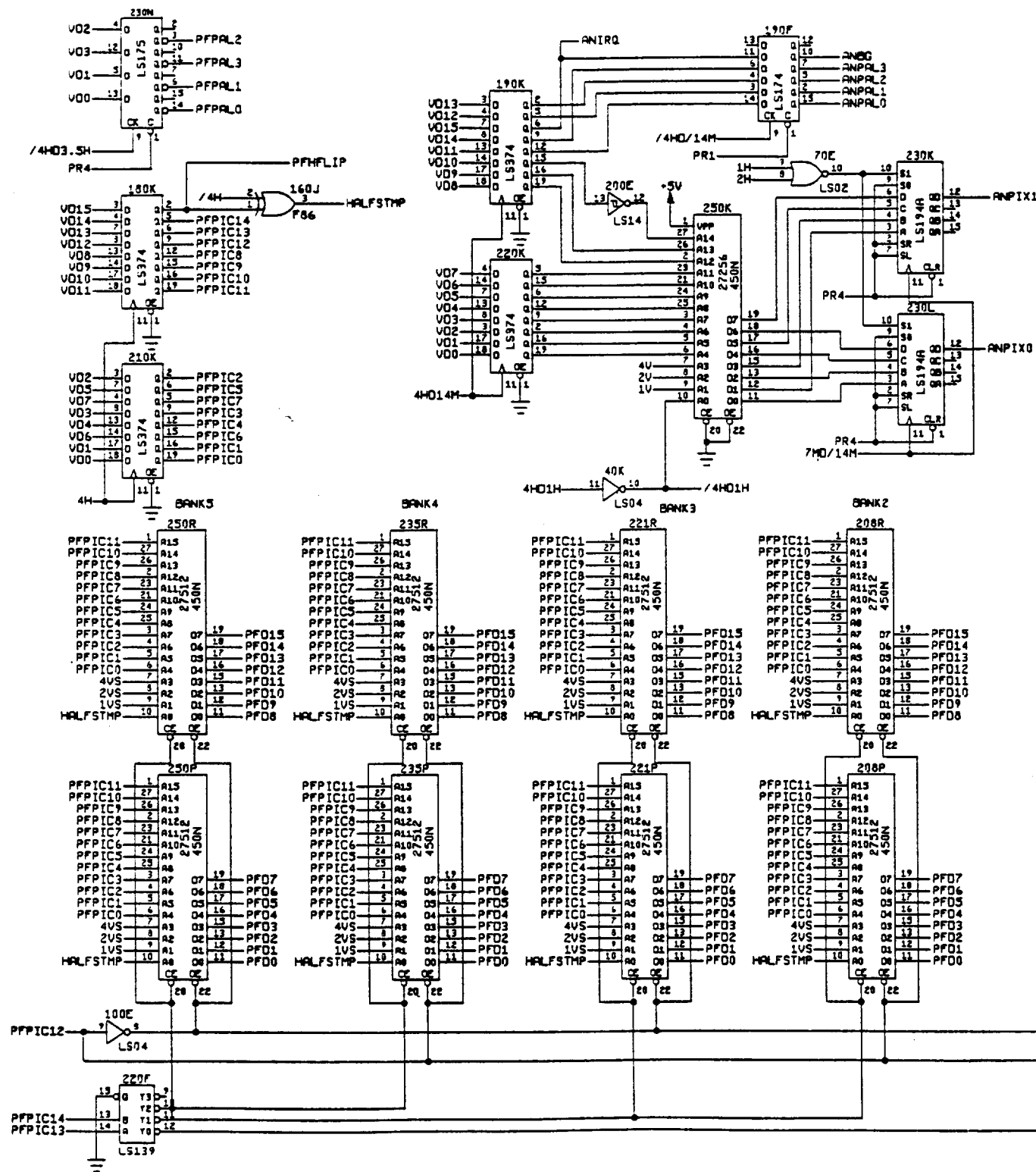

Figure 5-1 Skull & Crossbones Game PCB Assembly Schematic Diagram, Sheet 5 of 10

046903-01 D

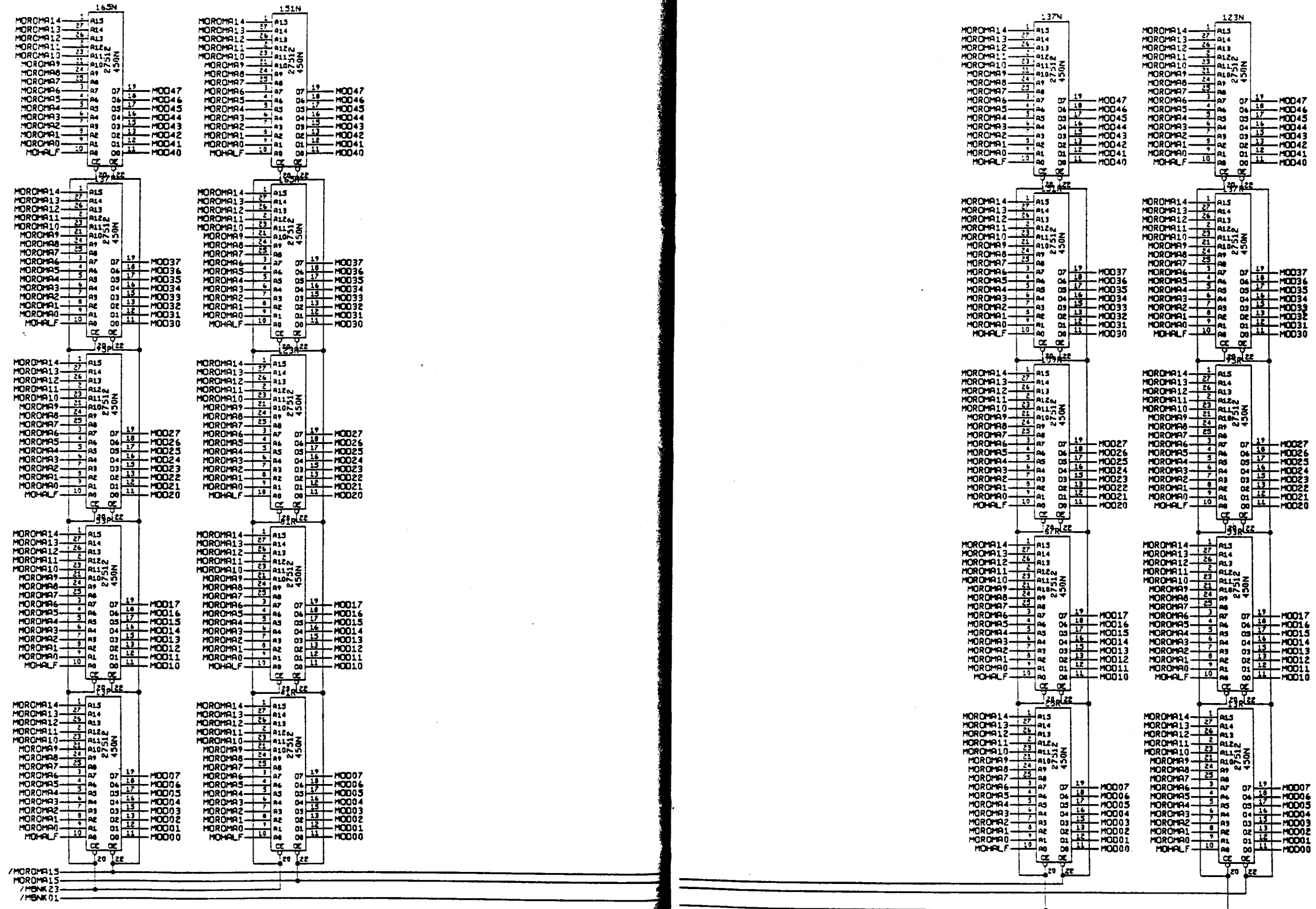

Figure 5-1 Skull & Crossbones Game PCB Assembly Schematic Diagram, Sheet 7 of 10

046903-01 D

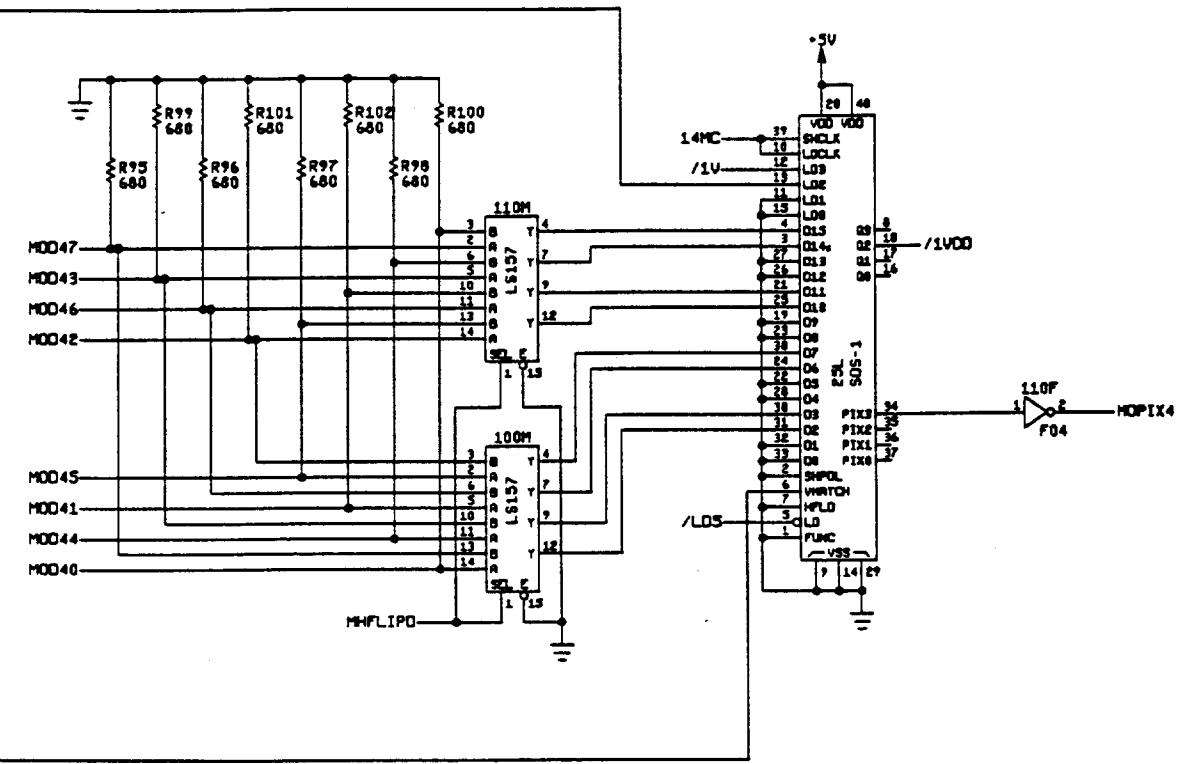
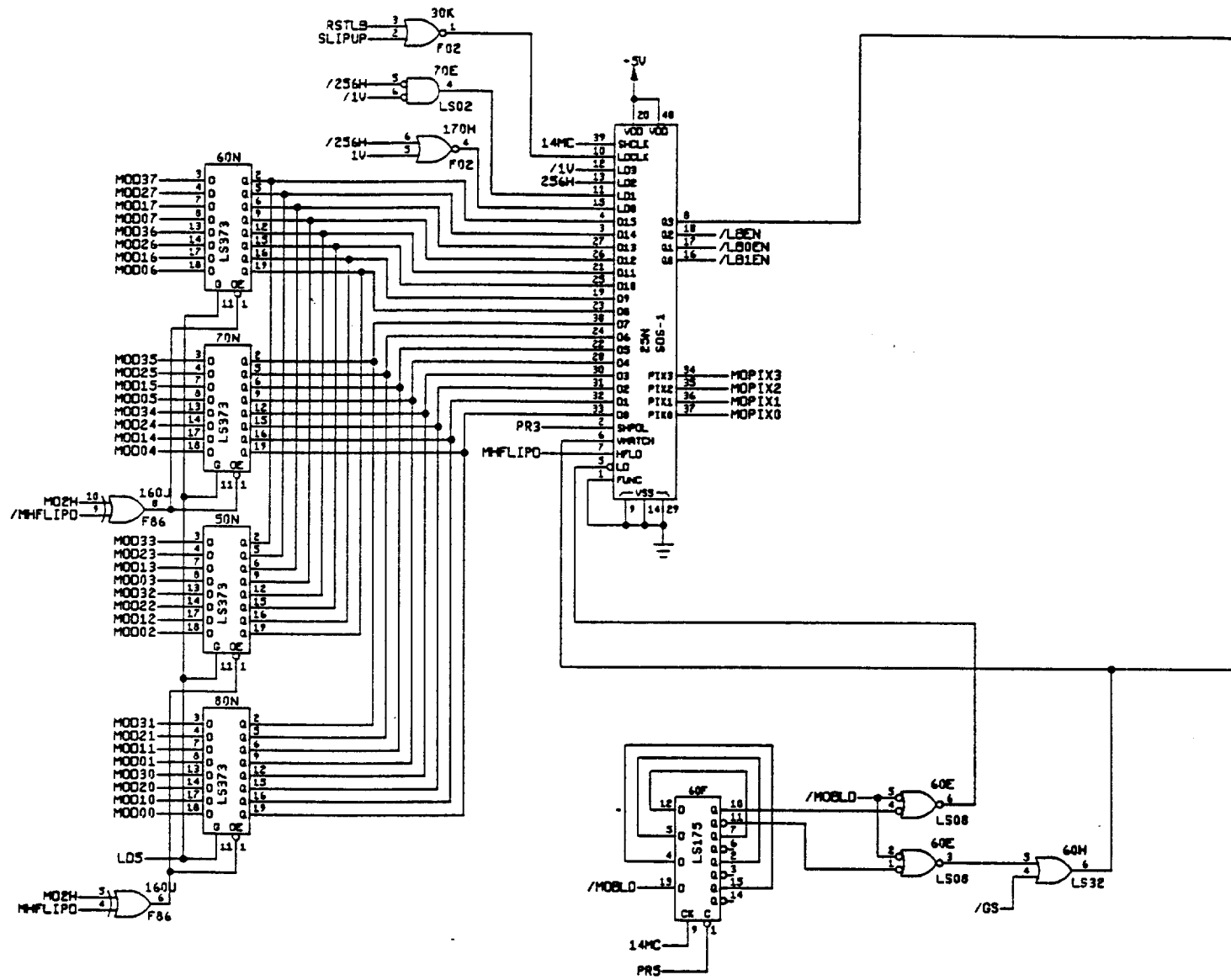

Figure 5-1 Skull & Crossbones Game PCB Assembly Schematic Diagram, Sheet 8 of 10

046903-01 D

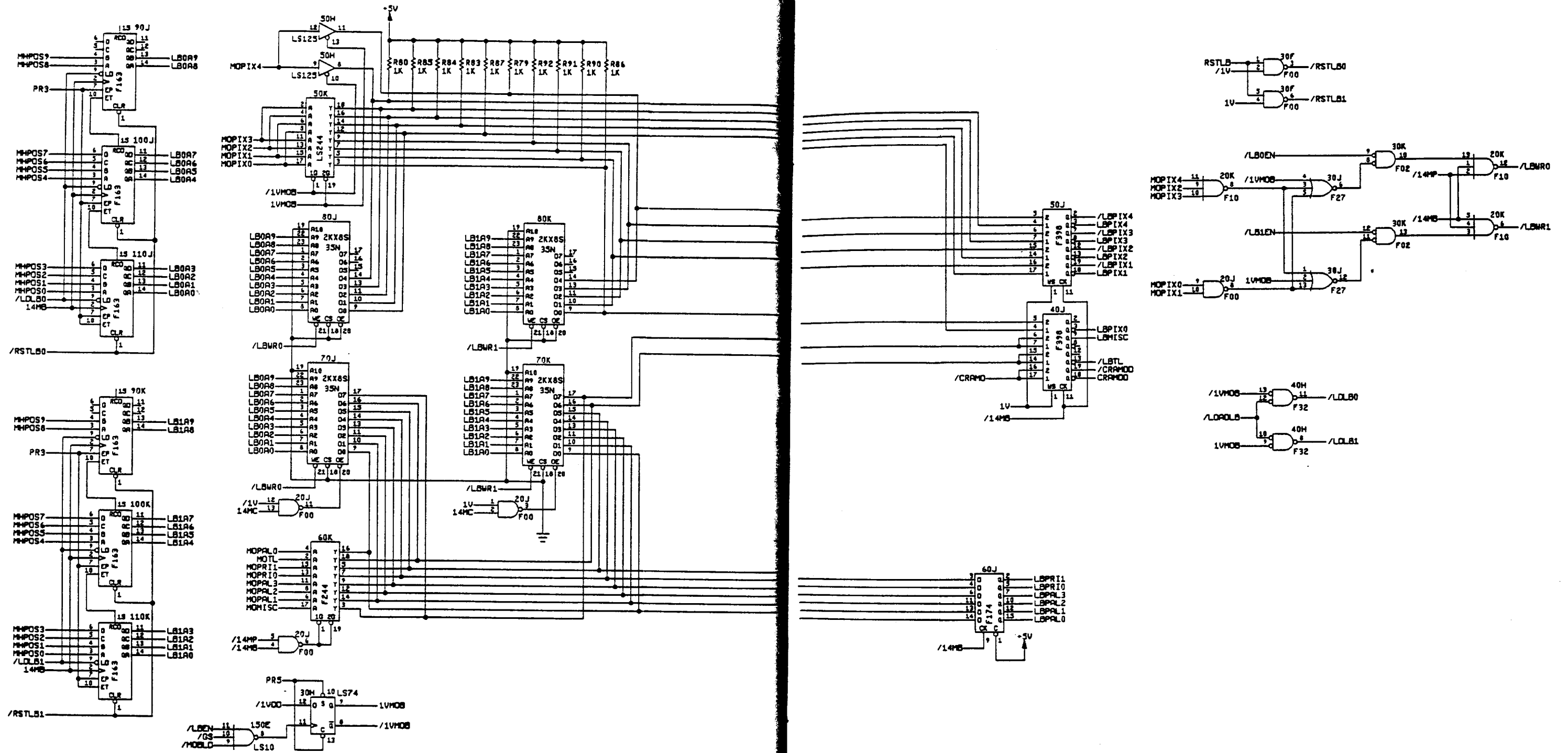

Figure 5-1 Skull & Crossbones Game PCB Assembly Schematic Diagram, Sheet 9 of 10

046903-01 D

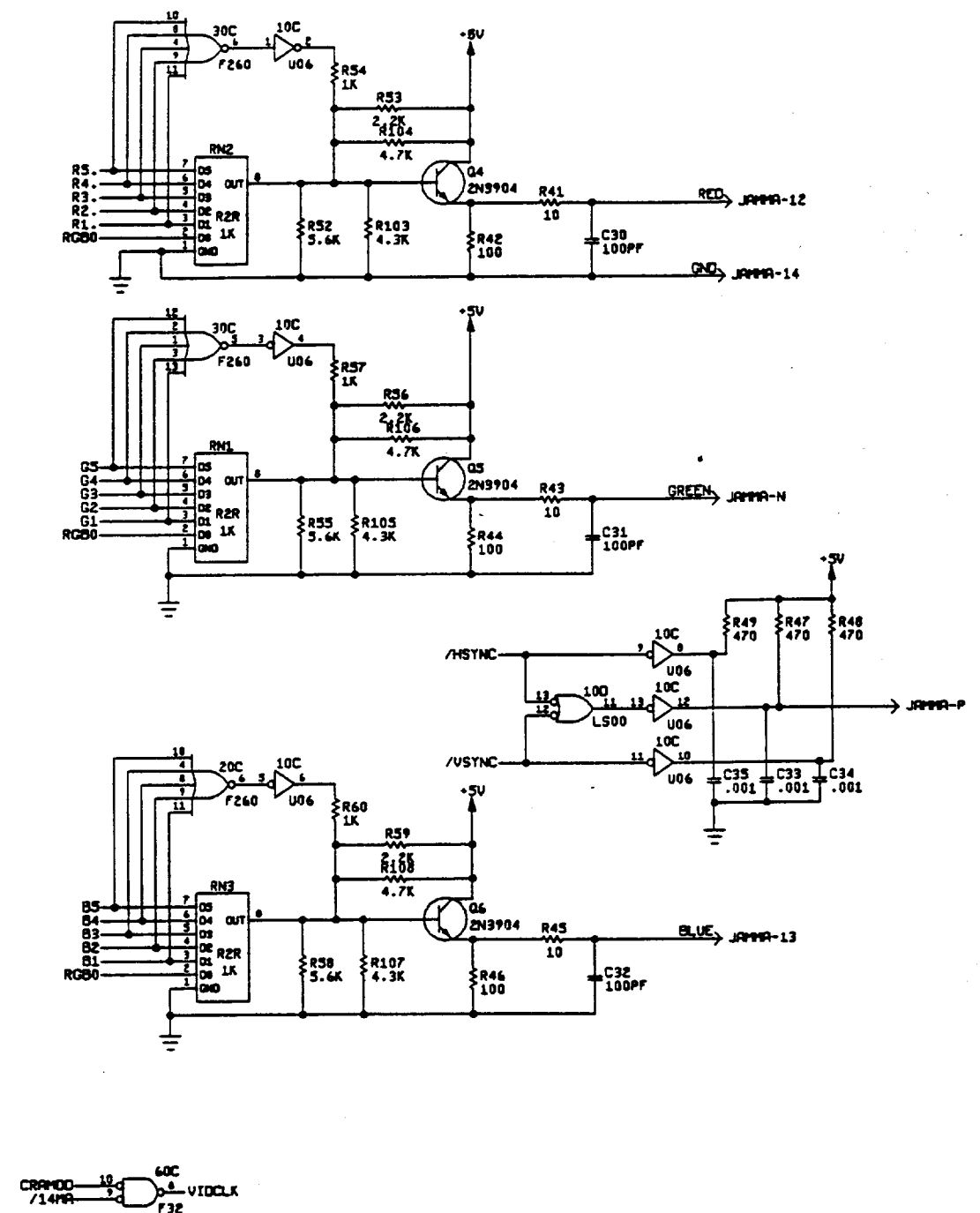
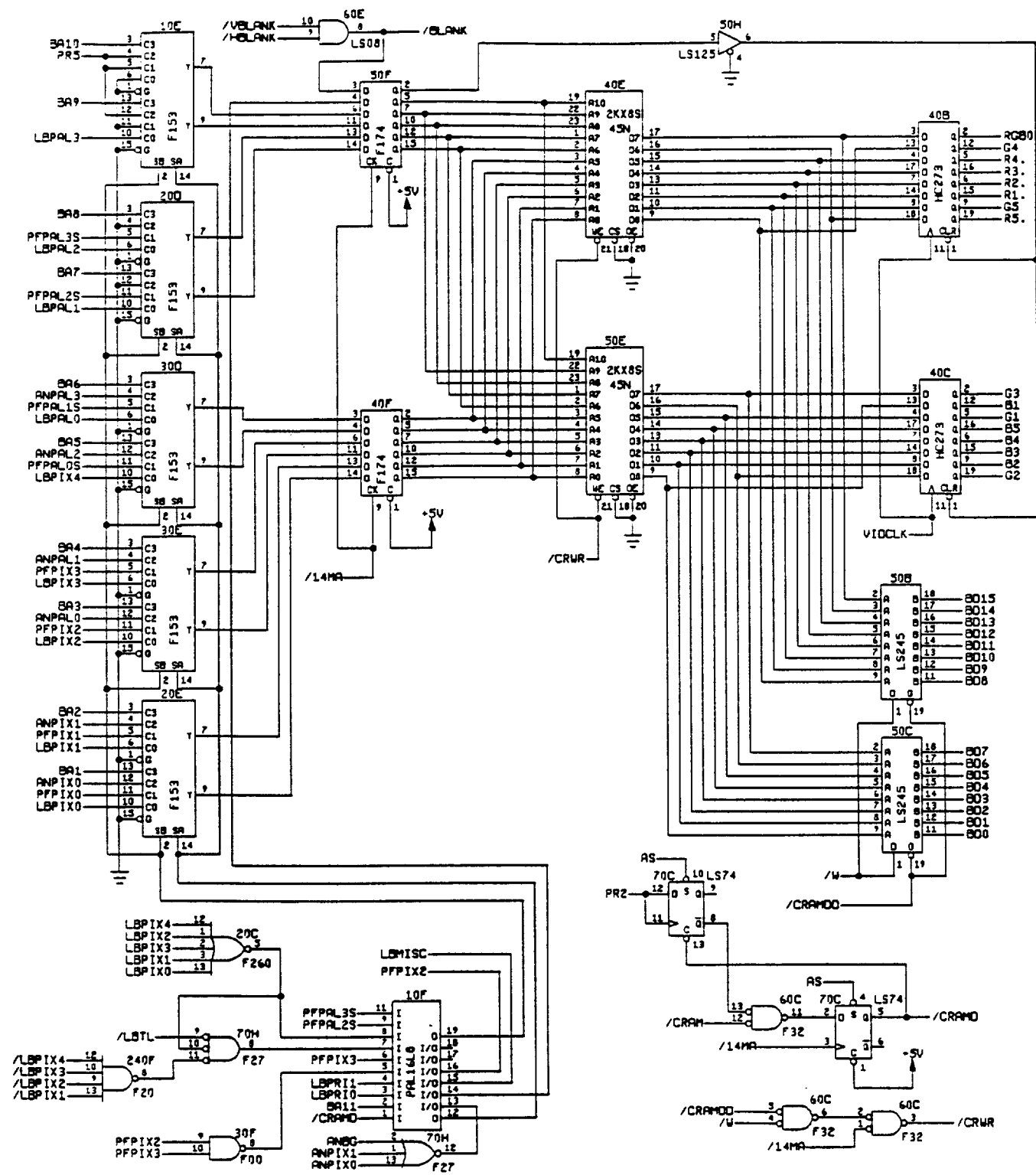

Figure 5-1 Skull & Crossbones Game PCB Assembly Schematic Diagram,
 Sheet 10 of 10
 046903-01 D

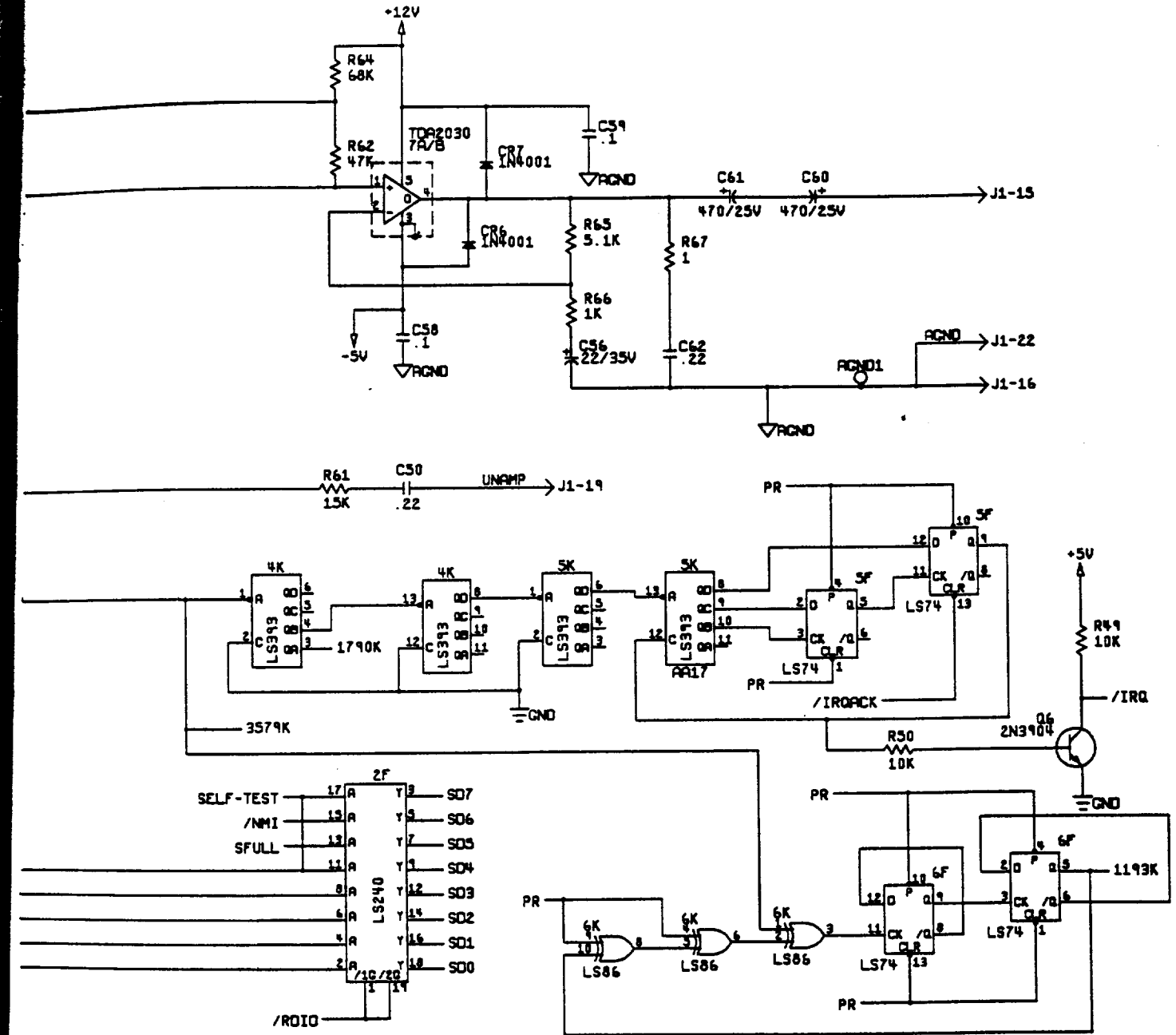
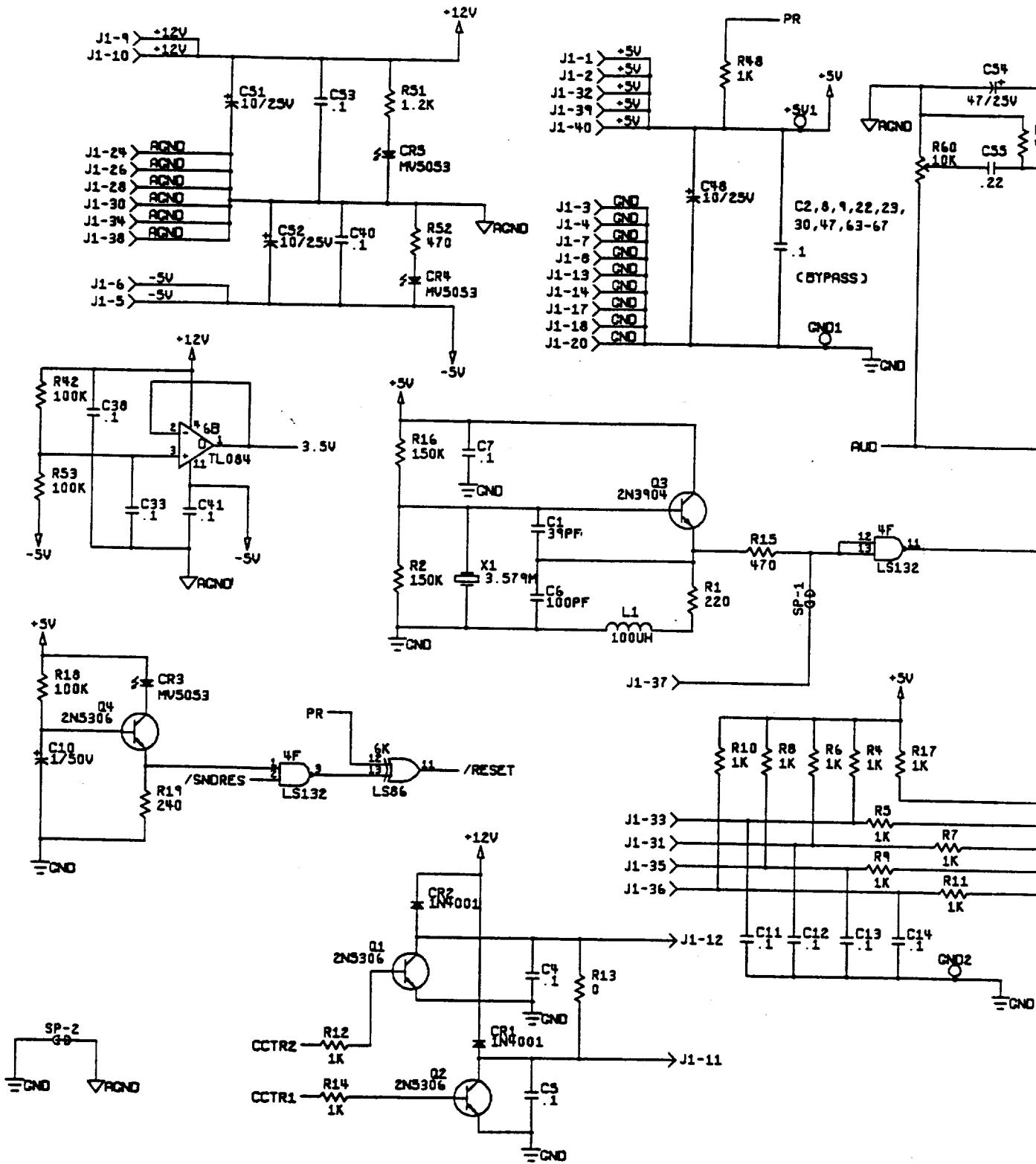

Figure 5-2 Skull & Crossbones JSA Audio II PCB Assembly Schematic Diagram, Sheet 1 of 3
046487-01 D

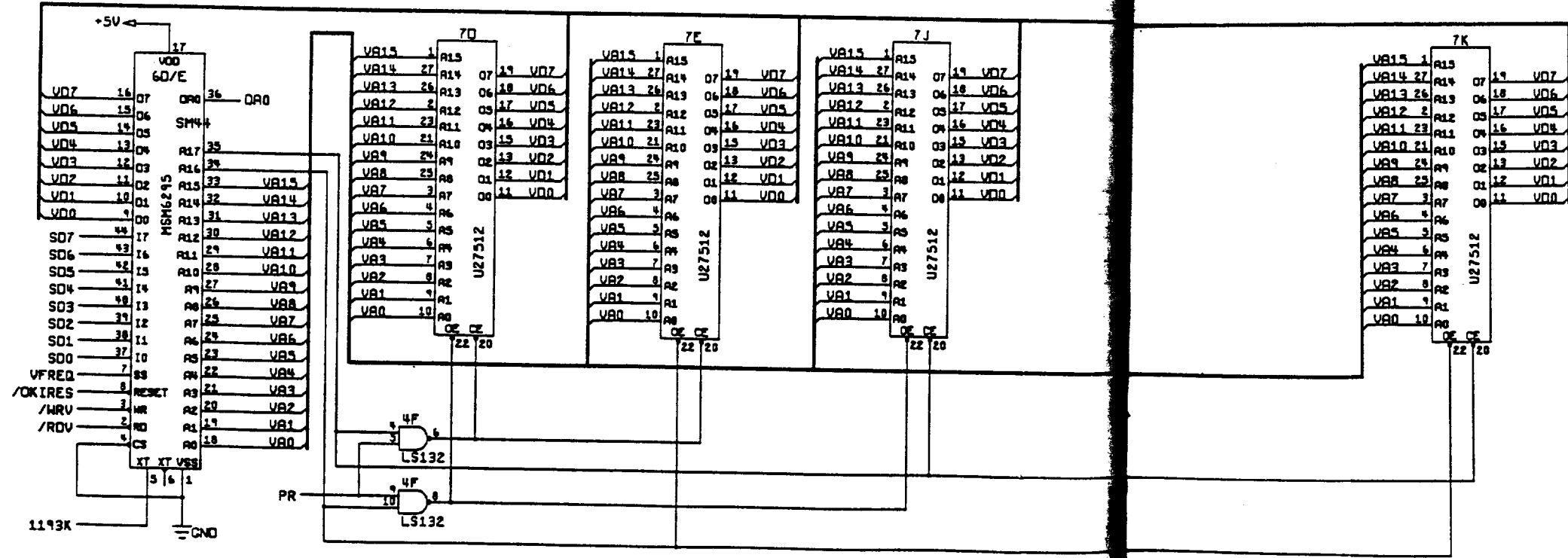
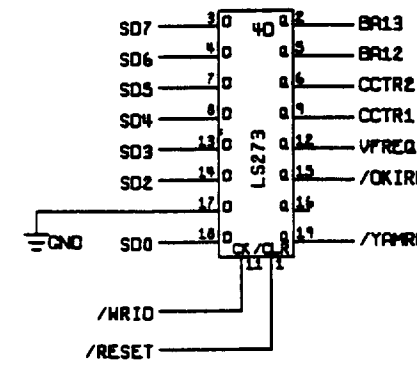
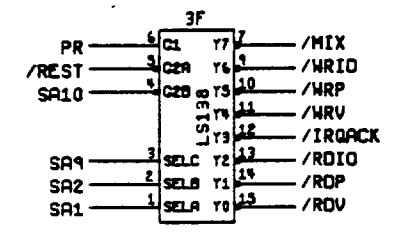
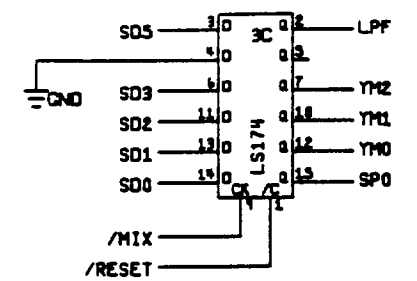
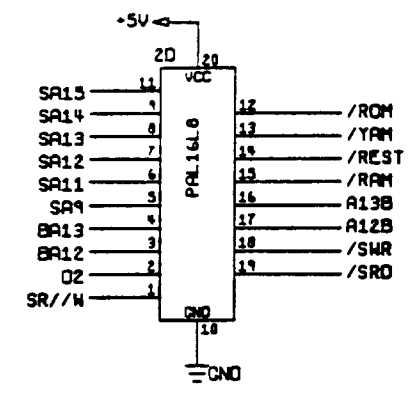
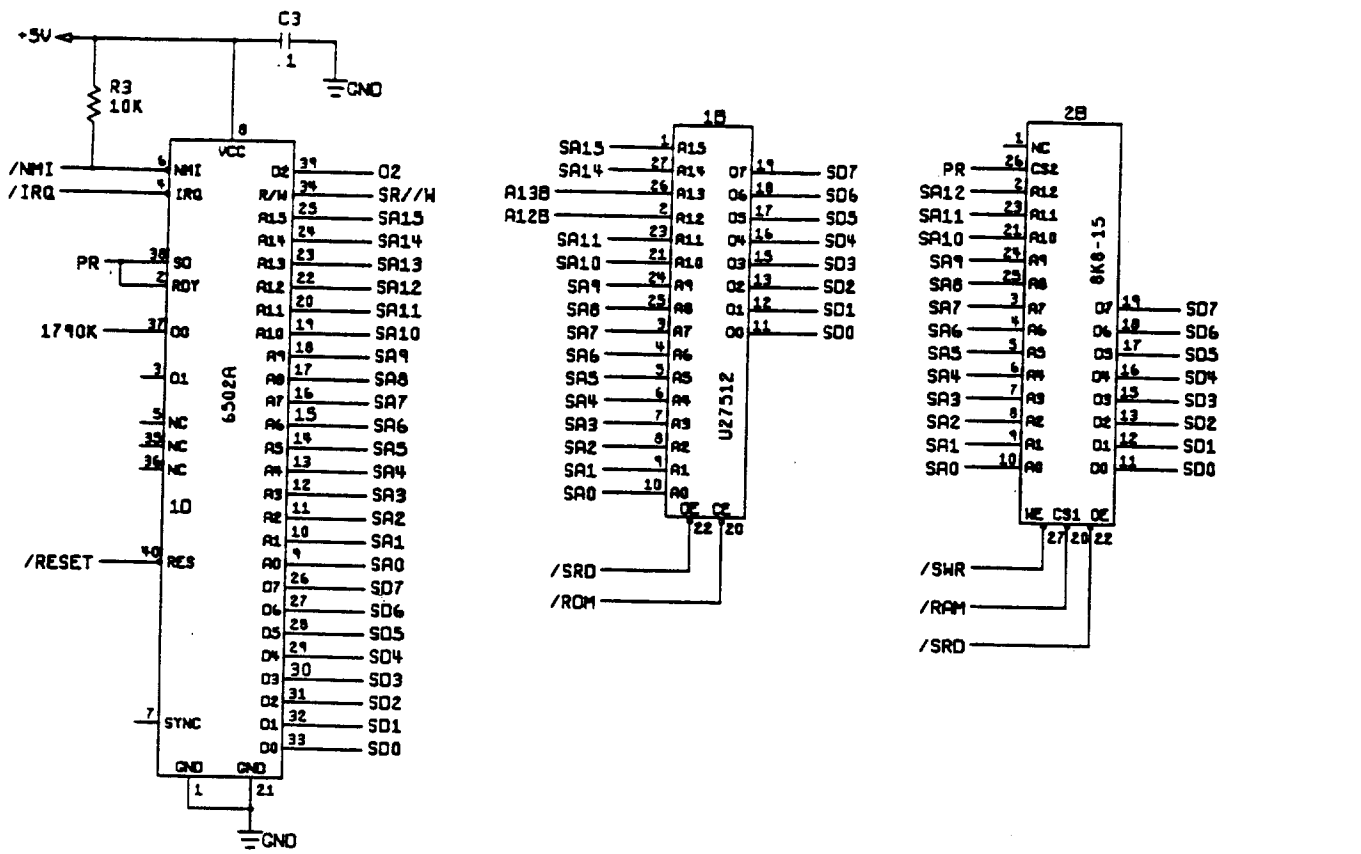

Figure 5-2 Skull & Crossbones JSA Audio II PCB Assembly Schematic Diagram, Sheet 2 of 3

046487-01 D

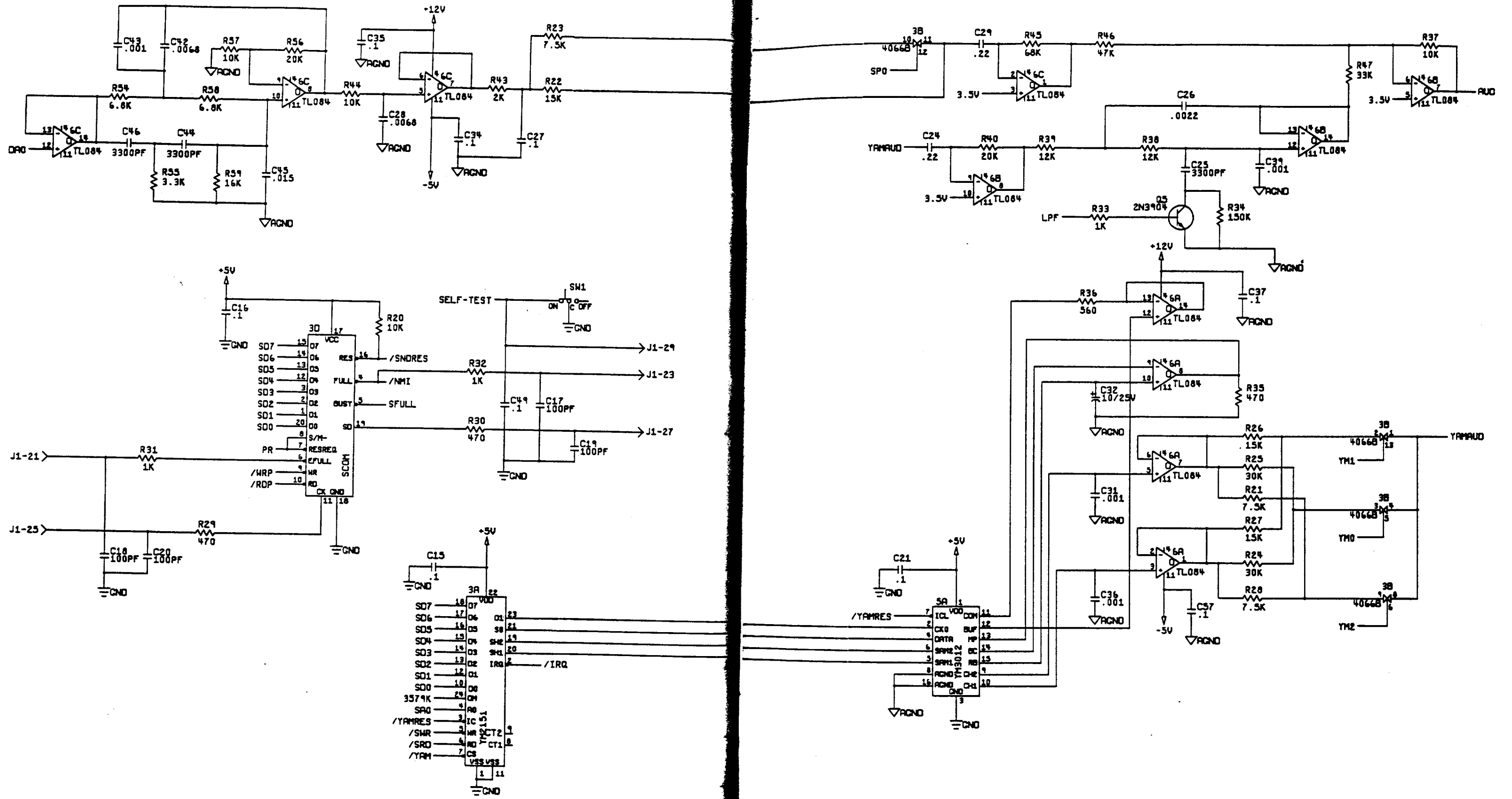

Figure 5-2 Skull & Crossbones JSA Audio II PCB Assembly Schematic Diagram,
 Sheet 3 of 3
 046487-01 D

SKULL & CROSSBONES MEMORY MAP

HEXADECIMAL	ADDRESS		DATA		FUNCTION
	AAAA AAAA AAAA AA	-----		DDDD DD	
	2222 1111 1111 11AA AAAA AAAA	-----	R/	1111 11DD DDDD DDDD	
	3210 9876 5432 1098 7654 3210	-----	W	5432 1098 7654 3210	
000000-07FFFF	0XXX XAAA AAAA AAAA AAAA AAAA	R	DDDD DDDD DDDD DDDD	512K BYTES PROGRAM ROM	
038000-03FFFF	0XXX X011 1AAA AAAA AAAA AAAA	R	DDDD DDDD DDDD DDDD	32K BYTES SLAPSTIC PROGRAM ROM SPACE	
FF0C00	1XXX XXXX 0000 11XX XXXX XXXX	W		UNLOCK EEROM	
FF1401	1XXX XXXX 0001 01XX XXXX XXX1	W	DDDD DDDD	AUDIO WRITE	
FF1800	1XXX XXXX 0001 10XX XXXX XXXX	W		AUDIO RESET	
FF1F80	1XXX XXXX 0001 1111 1XXX XXXX	W		WATCHDOG	
FF1F00	1XXX XXXX 0001 1111 0XXX XXXX	W		VIDEO IRQ ACKNOWLEDGE	
FF2000-FF2FFE	1XXX XXXX 001X AAAA AAAA AAA0	R/W	XDDD DDDD DDDD DDDD	COLOR RAM	
FF4801	1XXX XXXX 0100 1XXX XXXX XXX1	R	DDDD DDDD	AUDIO READ	
FF5800	1XXX XXXX 0101 1XXX XXXX XX00	R	DDDD DDDD	INPUTS - PLAYER 1	
		R	DDDD	LEFT PLAYER JOYSTICK (U, D, L, R)	
			D	LEFT AUX #1 (DEVELOPMENT ONLY)	
			D	LEFT AUX #2 (DEVELOPMENT ONLY)	
			D	LEFT TURN	
			D	LEFT SWORD	
FF5802	1XXX XXXX 0101 1XXX XXXX XX00	R	DDDD DDDD	INPUTS - PLAYER 2	
		R	DDDD	RIGHT PLAYER JOYSTICK (U, D, L, R)	
			D	RIGHT AUX #1 (DEVELOPMENT ONLY)	
			D	RIGHT AUX #2 (DEVELOPMENT ONLY)	
			D	RIGHT TURN	
			D	RIGHT SWORD	
FF5803	1XXX XXXX 0101 1XXX XXXX XX11	R	DDDD	STATUS	
	1XXX XXXX 0101 1XXX XXXX XX11	R	D	SELF-TEST	
	1XXX XXXX 0101 1XXX XXXX XX11	R	D	AUDIO BUSY FLAG	
	1XXX XXXX 0101 1XXX XXXX XX11	R	D	VBLANK	
	1XXX XXXX 0101 1XXX XXXX XX11	R	D	HBLANK	
FF6001-FF6FFF	1XXX XXXX 011X AAAA AAAA AAA1	R/W	DDDD DDDD	EEROM	
FF8000-FFBFFE	1XXX XXXX 100A AAAA AAAA AAA0	R/W	DDDD DDDD DDDD DDDD	SCROLLING PLAYFIELD RAM	
FFC000-FFCFE	1XXX XXXX 1100 AAAA AAAA AAA0	R/W	DDDD DDDD DDDD DDDD	ALPHANUMERICS RAM	
FFD000-FFDFFE	1XXX XXXX 1101 AAAA AAAA AAA0	R/W	DDDD DDDD DDDD DDDD	MOTION OBJECT RAM	
FFE000-FFFFF	1XXX XXXX 111A AAAA AAAA AAAA	R/W	DDDD DDDD DDDD DDDD	PROGRAM RAM	

Table 1 RAM Error Locations

Error Message	Display Background	Location on Game PCB
Video RAM bad	Red with black background	250H, 235H, 221H, 208H
Color RAM bad	Multicolor horizontal stripes	40E, 50E

Table 2 ROM Error Locations

Error Address	Location on Game PCB
000000	228C(0L) 228A(0H)
020000	213C(1L) 213A(1H)
040000	200C(2L) 200A(2H)
070000	185C(3L) 185A(3H)

Figure 5-3 Skull & Crossbones Faulty RAM/ROM Tables & Memory Map

N O T E S



Skull & Crossbones™ Statistics Sheet

Statistics Screen:

- Left (Mechanism) Coins _____
- Right (Mechanism) Coins _____
- New Players _____
- Bonus Coins _____
- 0-Player Minutes _____
- 1-Player Minutes _____
- 2-Player Minutes _____
- Left-Player Minutes _____
- Right-Player Minutes _____
- Sessions _____
- Error Count _____

- Total Coins _____
 - 1-Player Coins _____
 - 2-Player Coins _____
 - Average Time/Coin _____
 - Average 1-Player Time/Coin _____
 - Average 2-Player Time/Coin _____

Glossary

AC

Alternating current; from zero it rises to a maximum positive level, then passes through zero again to a maximum negative level.

ACTIVE STATE

The true state of a signal. For example: The active state for is low.

ADDRESS

A value that identifies a specific location of data in memory; normally expressed in hexadecimal notation.

ANALOG

Measurable in an absolute quantity (as opposed to on or off). Analog devices are volume controls, light dimmers, stereo amplifiers, etc.

ANODE

The positive (arrow) end of a diode.

AMPLIFIER

A device used to increase the strength of an applied signal.

AMPLITUDE

The maximum instantaneous value of a waveform pulse from zero.

ASTABLE

Having no normal state. An astable device will free-run or oscillate as long as operating voltage is applied. The oscillation frequency is usually controlled by external circuitry.

AUXILIARY COIN SWITCH

A momentary-contact pushbutton switch with a black cap located on the utility panel. The auxiliary coin switch adds credits to the game without activating a coin counter.

BEZEL

A cut, formed, or machined retention device, such as the conical device used to mount a pushbutton switch to a control panel, or the formed device used to frame the video display screen.

BIDIRECTIONAL

Able to send or receive data on the same line (e.g., the data bus of a microprocessor).

BINARY

A number system that expresses all values by using two digits (0 and 1).

BIT

A binary digit; expressed as 1 or 0.

BLANKING

Turning off the beam on a cathode-ray tube during retrace.

BLOCK DIAGRAM

A drawing in which functional circuitry units are represented by blocks. Very useful during initial troubleshooting.

BUFFER

1. An isolating circuit designed to eliminate the reaction of a driven circuit on the circuits driving it (e.g., a buffer amplifier).

2. A device used to supply additional drive capability.

BUS

An electrical path over which information is transferred from any of several sources to any of several destinations.

CAPACITOR

A device capable of storing electrical energy. A capacitor blocks the flow of DC current while allowing AC current to pass.

CATHODE

The negative end of a diode.

CHIP

An integrated circuit comprising many circuits on a single wafer slice.

CLOCK

A repetitive timing signal for synchronizing system functions.

COINCIDENCE

Occurring at the same time.

COIN COUNTER

A 6-digit electromechanical device that counts the coins inserted in the coin mechanism(s).

COIN MECHANISM

A device on the inside of the coin door that inspects the coin to determine if the correct coin has been inserted.

COMPLEMENTARY

Having opposite states, such as the outputs of a flip-flop.

COMPOSITE SYNC

Horizontal and vertical synchronization pulses that are bused together into a single signal. This signal provides the timing necessary to keep the display in synchronization with the game circuitry.

COMPOSITE VIDEO

Complete video signal from the game system to drive the display circuitry, usually comprising H SYNC, V SYNC, and the video.

CREDIT

One play for one person based on the game switch settings.

CRT

Cathode-ray tube.

DATA

General term for the numbers, letters, and symbols that serve as input for device processing.

DARLINGTON

A two-transistor amplifier that provides extremely high gain.

DC

Direct current, meaning current flowing in one direction and of a fixed value.

DEFLECTION YOKE

Electromagnetic coils around the neck of a cathode-ray tube. One set of coils deflects the electron beam horizontally and the other set deflects the beam vertically.

DIAGNOSTICS

A programmed routine for checking circuitry. For example: the self-test is a diagnostic routine.

DIODE

A semiconductor device that conducts in only one direction.

DISCRETE

Non-integrated components, such as resistors, capacitors, and transistors.

DMA

Direct memory access. DMA is a process of accessing memory that bypasses the microprocessor logic. DMA is normally used for transferring data between the input/output ports and memory.

DOWN TIME

The period during which a game is malfunctioning or not operating correctly due to machine failure.

EAROM

Electrically alterable read-only memory (see ROM). The EAROM is a memory that can be changed by the application of high voltage.

FLYBACK

A step-up transformer used in a display to provide the high voltage.

GATE

1. A circuit with one output that responds only when a certain combination of pulses is present at the inputs.

2. A circuit in which one signal switches another signal on and off.

3. To control the passage of a pulse or signal.

HARNESS

A prefabricated assembly of insulated wires and terminals ready to be attached to a piece of equipment.

HEXADECIMAL

A number system using the equivalent of the decimal number 16 as a base. The symbols 0-9 and A-F are usually used.

IMPLODE

To burst inward; the inward collapse of a vacuum tube.

I/O

Input/Output.

IRQ

Interrupt request. IRQ is a control signal to the microprocessor that is generated by external logic. This signal tells the microprocessor that external logic needs attention. Depending on the program, the processor may or may not respond.

LED

The abbreviation for a light-emitting diode.

LOCKOUT COIL

Directs coins into the coin return box when there is no power to the game.

LOGIC STATE

The binary (1 or 0) value at the node of a logic element or integrated circuit during a particular time. Also called the logic level. The list below shows the voltage levels corresponding to the logic states (levels) in a TTL system.

Logic 0, Low = 0 VDC to +0.8 VDC

Grey Area (Tri-State Level) = +0.8 VDC to +2.4 VDC

Logic 1, High = +2.4 VDC to +5 VDC

MULTIPLEXER

A device that takes several low-speed inputs and combines them into one high-speed data stream for simultaneous transmission on a single line.

NMI

Non-maskable interrupt. NMI is a request for service by the microprocessor from external logic. The microprocessor cannot ignore this interrupt request.

PAGE

A subsection of memory. A read-only memory device (see ROM) is broken into discrete blocks of data. These blocks are called pages. Each block has X number of bytes.

PCB

The abbreviation for a printed-circuit board.

PHOTOTRANSISTOR

A transistor that is activated by an external light source.

POTENTIOMETER

1. A resistor that has a continuously moving contact which is generally mounted on a moving shaft. Used chiefly as a voltage divider. Also called a pot (slang).

2. An instrument for measuring a voltage by balancing it against a known voltage.

RAM

Random-access memory. A device for the temporary storage of data.

RASTER-SCAN DISPLAY

A display system whereby images are displayed by continuously scanning the cathode-ray tube horizontally and vertically with an electron beam. The display system controls the intensity of the electron beam.

RETRACE

In a raster-scan display, retrace is the time during which the cathode-ray tube electron beam is resetting either from right to left or from bottom to top.

RESISTOR

A device designed to have a definite amount of resistance. Used in circuits to limit current flow or to provide a voltage drop.

ROM

Read-only memory. A device for the permanent storage of data.

SIGNATURE ANALYSIS

A process of isolating digital logic faults at the component level by means of special test equipment called signature

analyzers. Basically, signature analyzers (e.g., the ATARI® CAT Box) convert lengthy bit streams into four-digit hexadecimal signatures. The signature read by the analyzer at each circuit node is then compared with the known good signature for that node. This process continues until a fault is located.

TROUBLESHOOT

The process of locating and repairing a fault.

VECTOR

A line segment drawn between specific X and Y coordinates on a cathode-ray tube.

WATCHDOG

A counter circuit designed to protect the microprocessor from self-destruction if a program malfunction occurs. If

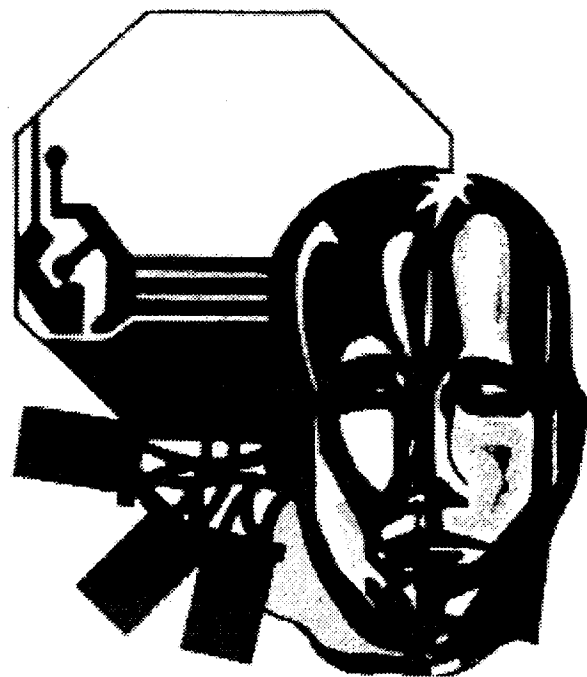

a malfunction does occur, the counter applies continuous pulses to the reset line of the microprocessor, which causes the microprocessor to keep resetting.

X-Y DISPLAY

A display system whereby images are displayed with vectors.

ZENER DIODE

A special diode used as a regulator. Its main characteristic is breaking down at a specified reverse-bias (Zener) voltage.

Warranty

Seller warrants that its printed-circuit boards and parts thereon are free from defects in material and workmanship under normal use and service for a period of ninety (90) days from date of shipment. Seller warrants that its video displays and laser-video disc players (in games supplied with displays and video-disc players) are free from defects in material and workmanship under normal use and service for a period of thirty (30) days from date of shipment. None of the Seller's other products or parts thereof are warranted.

If the products described in this manual fail to conform to this warranty, Seller's sole liability shall be, at its option, to repair, replace, or credit Buyer's account for such products which are returned to Seller during said warranty period, provided:

- (a) Seller is promptly notified in writing upon discovery by Buyer that said products are defective;
- (b) Such products are returned prepaid to Seller's plant; and
- (c) Seller's examination of said products discloses to Seller's satisfaction that such alleged defects existed and were not caused by accident, misuse, neglect, alteration, improper repair, installation, or improper testing.

In no event shall Seller be liable for loss of profits, loss of use, incidental or consequential damages.

Except for any express warranty set forth in a written contract between Seller and Buyer which contract supersedes the terms herein, this warranty is expressed in lieu of all other warranties expressed or implied, including the implied warranties of merchantability and fitness for a particular purpose, and of all other obligations or liabilities on the Seller's part, and it neither assumes nor authorizes any other person to assume for the Seller any other liabilities in connection with the sale of products by Seller.

The use of any non-Atari parts may void your warranty, according to the terms of the warranty. The use of any non-Atari parts may also adversely affect the safety of your game and cause injury to you and others. Be very cautious in using non-Atari-supplied components with our games, in order to ensure your safety.

Atari distributors are independent, being privately owned and operated. In their judgment they may sell parts or accessories other than Atari parts or accessories. Atari Games Corporation cannot be responsible for the quality, suitability or safety of any non-Atari part or any modification including labor which is performed by such distributor.