

R·TYPE™

UPRIGHT

NO: RTP-UP-US

Nintendo®

OPERATION MANUAL



R·TYPE™
TM AND © 1987 Irem Corporation
Licensed exclusively to
Nintendo of America Inc.

TABLE OF CONTENTS

I. Location Setup	1
A. Game Installation	1
B. Voltage Selection	1-2
C. Power On/Off Switch	3
D. Grounding of Game	3
II. Adjustments	4
A. Adjustments of Video Monitor	4
B. R•Type P.C. Board	5
III. Maintenance and Repair	6
A. Fuse Replacements	6
B. Cleaning	6
C. Operation Panel	6
1. Operation Panel Removal	6
2. Micro-Switch Replacement	6
3. Lubrication of 8 way Controller	7
D. Front Screen and Video Monitor Removal	8-9
E. Game P.C. Board Removal	10
IV. Radio Frequency Interference	10
V. Wiring Diagram	11-12
VI. F.C.C. Schematics	13
VII. R•Type P.C. Board Schematics	(insert)
VIII. Power Supply Schematics	14
IX. Monitor Schematics	(insert)
X. Parts Lists	15
A. Body Parts	15-18
B. Control Panel Assembly	19-20
C. Wiring Harnesses	21
D. R•Type P.C. Board Assembly	22-25
E. Power Supply	26
XI. Diagnostic Test	27-28

WARNING

Check before plugging the game in.

I. LOCATION SETUP

R•Type – Upright is shipped ready for operation. Please check the following to insure proper operation.

- (1) Check the exterior of the game for shipping damage, dents, chips, or broken parts.
- (2) Remove the screws on the rear door panel.
- (3) Unlock and open the rear door panel, as well as the service door, and inspect the interior of the game as follows:
 - a) **Check that all the plug-in connectors are firmly connected.**
 - b) **Check all main subassemblies (monitor, power supply, control panel, etc.) to ensure they are securely mounted.**

A. Game installation

- (1) Requirements

Amperage:	1.2 AMPS
Temperature:	0 to 38 degrees Celsius (32 to 100 degrees Fahrenheit)
Humidity:	Not over 95% relative
Space required:	$32\frac{3}{8} \times 23\frac{3}{4}$
Height:	$68\frac{3}{8}$

B. Voltage selection

Before plugging in your game, make sure the terminal block of the power transformer is correct for your location's line voltage. See figure 1.

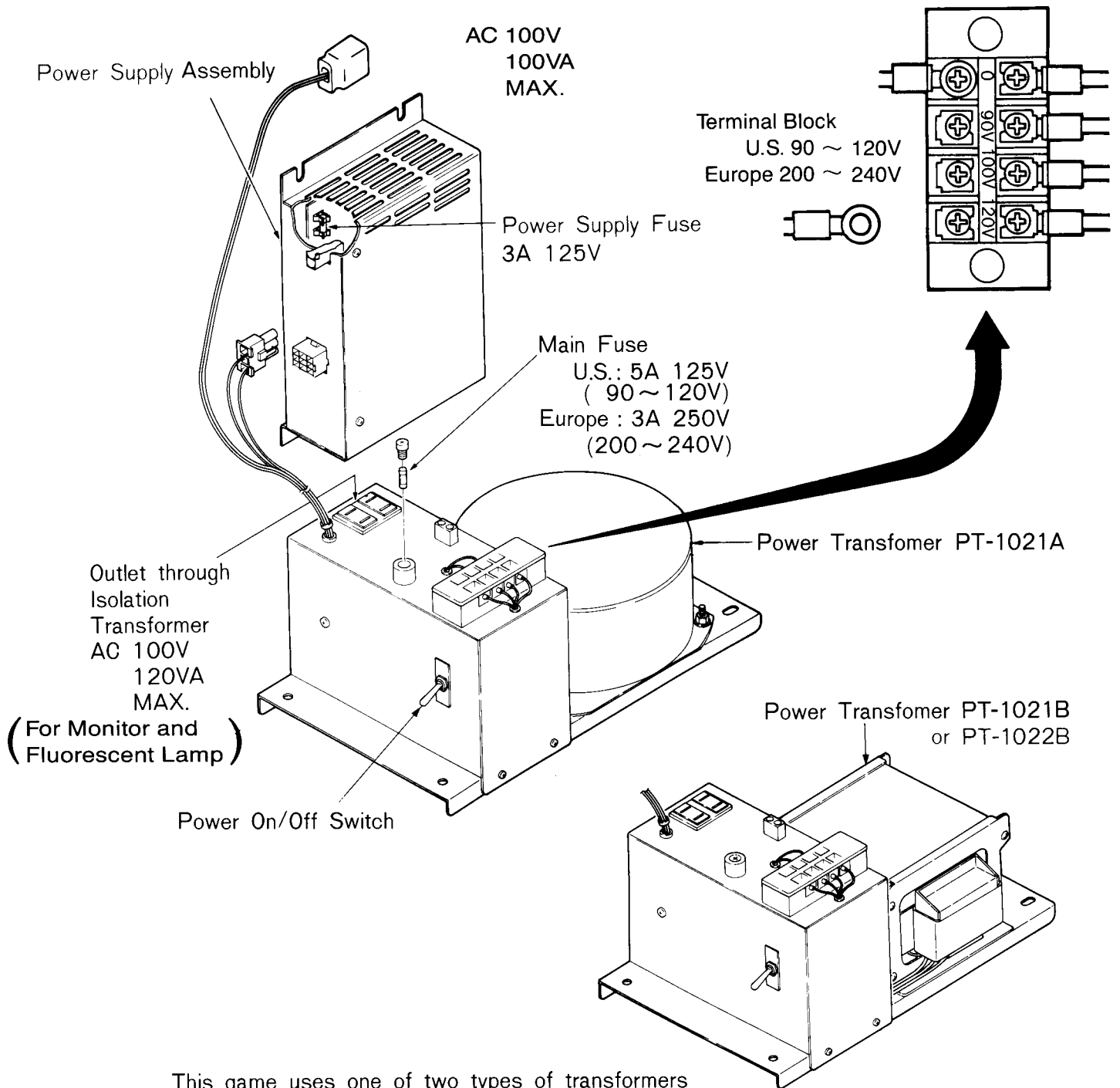

This game uses one of two types of transformers which are different in appearance but identical in function. The two types can be interchanged.

Fig. 1 Power Supply Assembly, Power Transformer and Voltage Selection

C. Power on/off switch

A power on/off switch is located in the rear of the game at the bottom left of the cabinet.

WARNING

Please be sure you use a grounded outlet for this game. Failure to do so may result in destruction of electronic components.

D. Grounding of Game (Use only if 3 wire outlet is unavailable.) See Fig. 2

- (1) A grounding wire should be connected to a grounding bar or a metal pipe which is firmly inserted into the ground.
- (2) Do not connect the grounding to a water pipe, because polyvinyl-chloride pipes are sometimes used in water lines, and the electronic continuity to the ground may be interrupted.
- (3) Absolutely do not connect the grounding wire to a gas pipe, as this can be extremely dangerous.

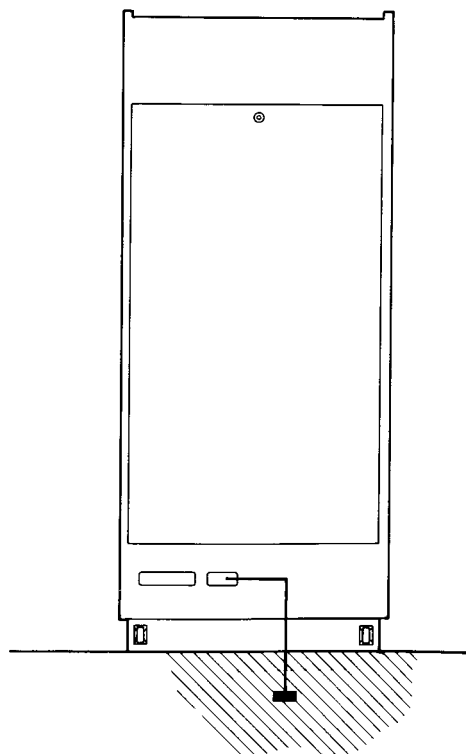

Fig. 2

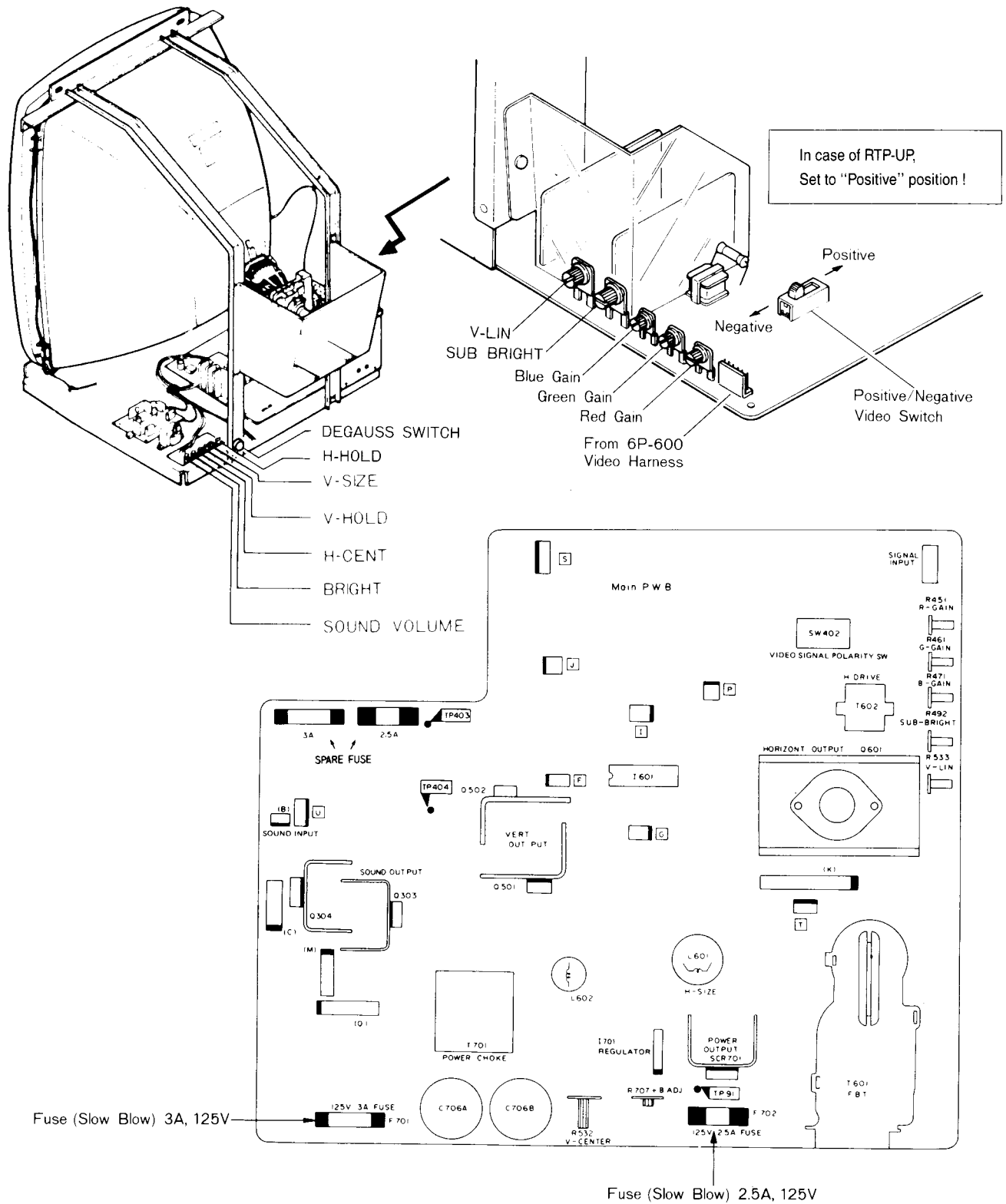
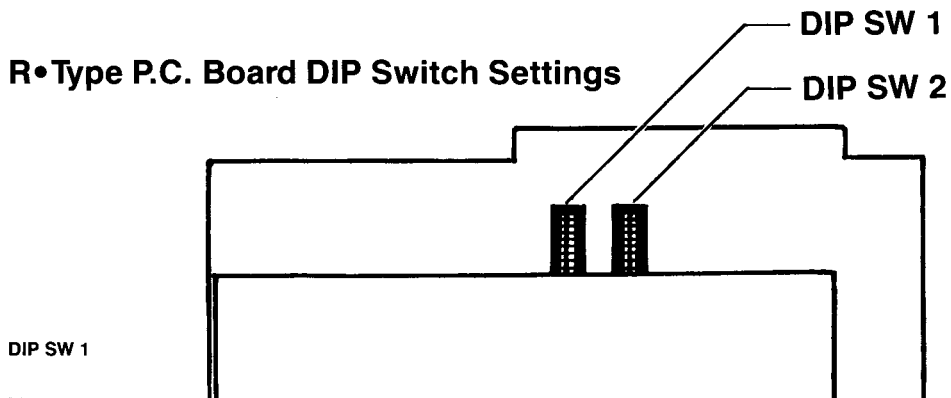

Fig. 6 Video Monitor : [Y51 Type] XM-2001N

WARNING

Do not touch the inside of the Video Monitor.
It contains many parts supplied with high voltage.

R•Type P.C. Board DIP Switch Settings



OPTIONS		SW	1	2	3	4	5	6	7	8	
NUMBER OF YOUR CRAFTS	3		OFF	OFF						*	
	2		ON	OFF							
	4		OFF	ON							
	5		ON	ON							
SOUND EFFECTS IN ATTRACTIVE MODE	NO				OFF					*	
	YES				ON						
EXTRA CRAFT GIVEN AT THE POINTS	100,200,350,500,700K					OFF				*	
	50,150,250,400,600K					ON					
MODE 2 3 OF DIP SW 2 ON	COIN SELECTOR A	1 COIN 1 PLAY					OFF	OFF			
		2 COINS 1 "					ON	OFF			
		3 " 1 "						OFF	ON		
		5 " 1 "						ON	ON		
MODE 1 3 OF DIP SW 2 OFF	COIN SELECTOR B	1 COIN 2 PLAYS							OFF	OFF	
		1 " 3 "							ON	OFF	
		1 " 5 "								OFF	ON
		1 " 6 "								ON	ON
MODE 1 3 OF DIP SW 2 OFF	FREE PLAY	1 " 1 PLAY					OFF	OFF	OFF	OFF	
		2 COINS 1 "					ON	OFF	OFF	OFF	
		3 " 1 "					OFF	ON	OFF	OFF	
		4 " 1 "					ON	ON	OFF	OFF	
		5 " 1 "					OFF	OFF	ON	OFF	
		6 " 1 "					ON	OFF	ON	OFF	
		1 COIN 2 PLAYS					OFF	ON	ON	OFF	
		1 " 3 "					ON	ON	ON	OFF	
		1 " 4 "					OFF	OFF	OFF	ON	
		1 " 5 "					ON	OFF	OFF	ON	
		1 " 6 "					OFF	ON	OFF	ON	
		2 " 3 "					ON	ON	OFF	ON	
3 " 2 "					OFF	OFF	ON	ON			
5 " 3 "					ON	OFF	ON	ON			
8 " 3 "					OFF	ON	ON	ON			
FREE PLAY					ON	ON	ON	ON			

N.B. 1) Select Coin Mode 1 in case a single coin or two selectors for coins of the same value are used.
2) Select Coin mode 2 in case 2 coin selectors of different values are used.

DIP SW 2

OPTIONS		SW	1	2	3	4	5	6	7	8
FLIP PICTURE	NO		OFF							*
	YES		ON							
CABINET TYPE	TABLE			OFF						*
	UPRIGHT			ON						
COIN MODE	MODE 1				OFF					*
	MODE 2				ON					
DIFFICULTY	NORMAL					OFF				*
	DIFFICULT					ON				
CONTINUITY	YES						OFF			*
	NO						ON			
FREEZE PICTURE	NO							OFF		*
	YES							ON		
NO DEATH MODE	NO								OFF	*
	YES								ON	
DIAGNOSTIC TEST	NO									OFF
	YES									ON

N.B. In the freeze picture mode, press 2P-start button to freeze and 1P-start button to restart the game.

*RECOMMEND SETTINGS

III. MAINTENANCE AND REPAIR

A. Fuse Replacements

This game contains 4 fuses. Replace fuses only with the same type as listed below.

Specification of Fuses

(1) Main Fuse	U.S. : 5A 125V (90~120V) Europe : 3A 250V (200~240V)
(2) Power Supply Fuse	3A 125V MIDGET
(3) Video Monitor Fuse	2.5A 125V MIDGET 3A 125V MIDGET

B. Cleaning

The exterior of the game, all metal parts and all glass parts can be cleaned with a nonabrasive cleanser.

C. Operation Panel

(1) Operation Panel Removal

Before repairing or replacing any switches or 8 way Controllers on the Operation Panel, unplug the game. Open the Service Door, and reach through the opening, and unlock the Clamps, located at each end on the underside of the Operation Panel.

(2) Micro-switch Replacement

Whenever you replace any micro-switch on the Operation Panel, a switch gap adjustment is needed as shown in Fig. 4. This adjustment is not necessary for the player option buttons.

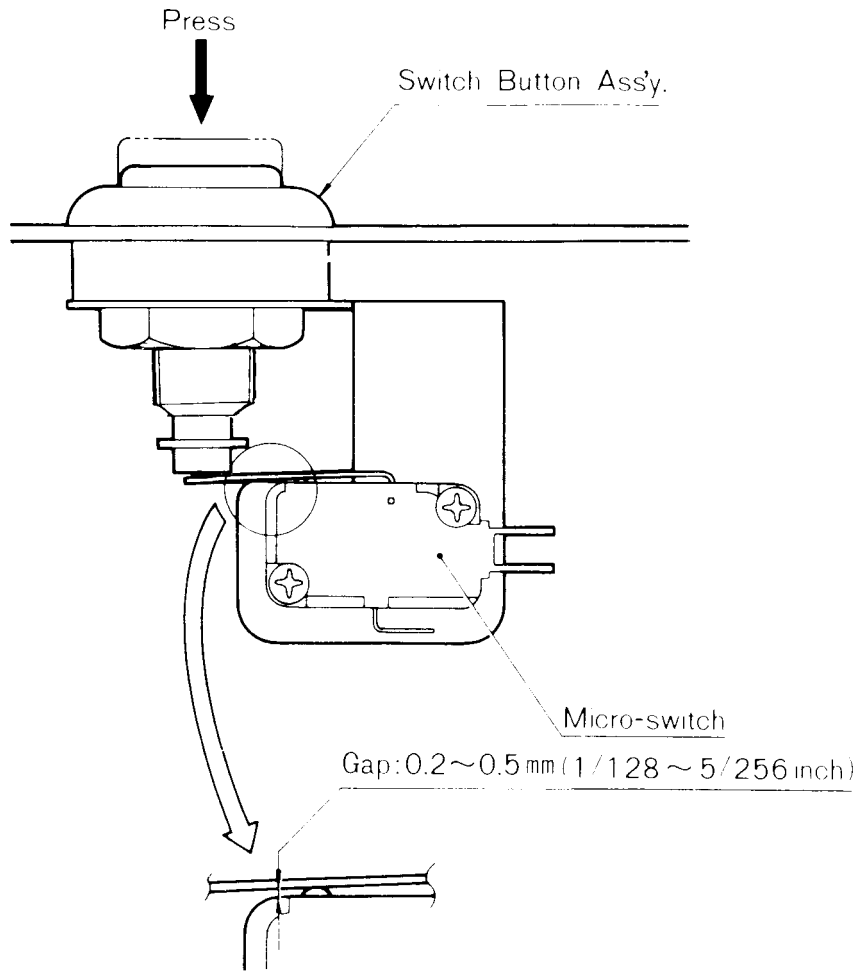

Fig. 4 Switch gap adjustment

(3) Lubrication for 8 way Controller

To maintain the 8 way Controller in good condition, lubricate the ball socket and 8 way Guide Plate approx. every 3 months. See Fig. 5.

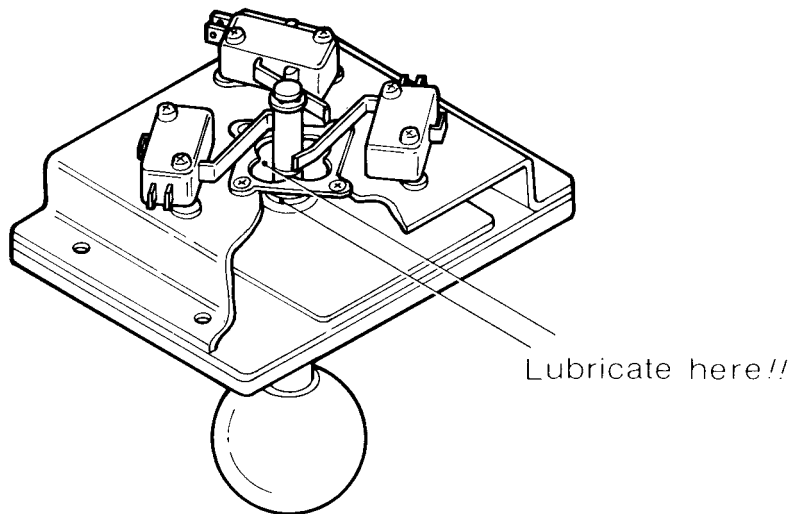

Fig. 5 Lubrication points

D. Front Screen and Video Monitor Removal

(1) Front Screen Removal

To remove the Front Screen, first remove the Control Panel by reaching through the Service Door and releasing the Control Panel Clasps. Pull the bottom of the Front Screen toward you allowing it to drop into the slots. Then pull out toward center of game. See Fig. 6

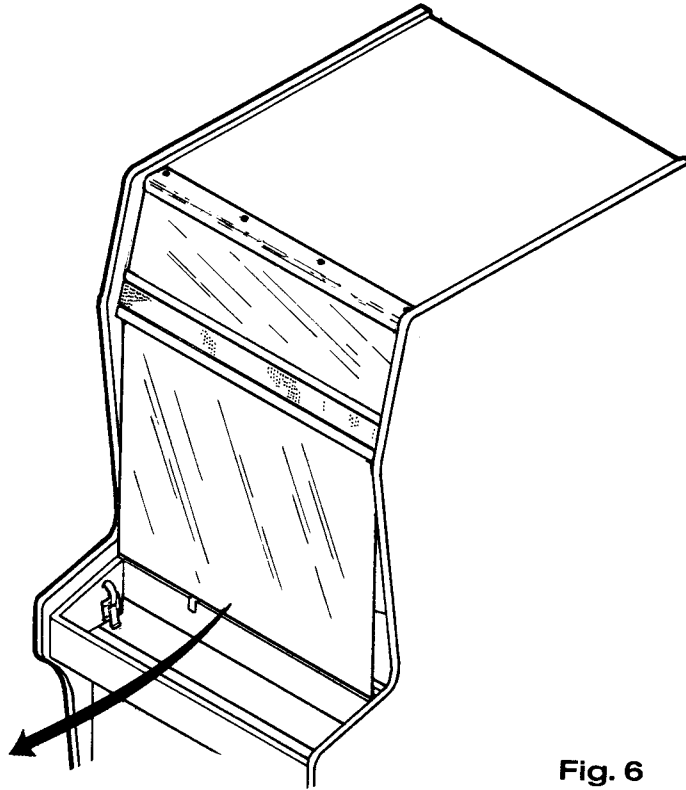

Fig. 6

(2) Video Monitor Removal

If you need to remove the Video Monitor, follow the instructions listed below. But the following procedure should only be performed by an experienced service technician.

WARNING

It is recommended the game be left unplugged for at least one hour before removing the Video Monitor. This will probably discharge the CRT, but extreme caution is still necessary.

- (a) Make sure game is unplugged.
- (b) Remove back door and unplug all the harnesses and cables from the Video Monitor.
- (c) Standing at the front opening of the game, remove the four mounting machine screws and flat washers. See Fig. 7.
- (d) Carefully lift the Video Monitor and pull out toward you.

WARNING

Use extreme caution and do not touch electrical parts of the yoke area with your hands or with any metal object in your hands.

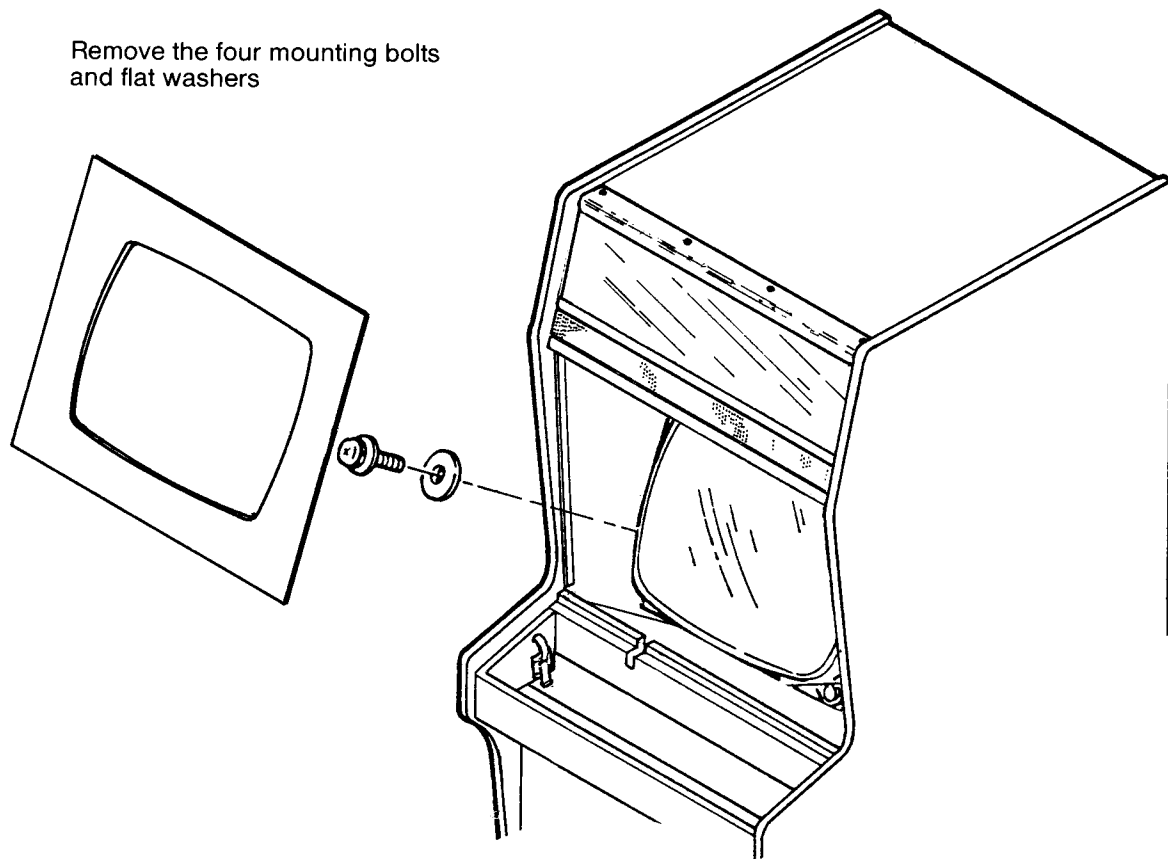
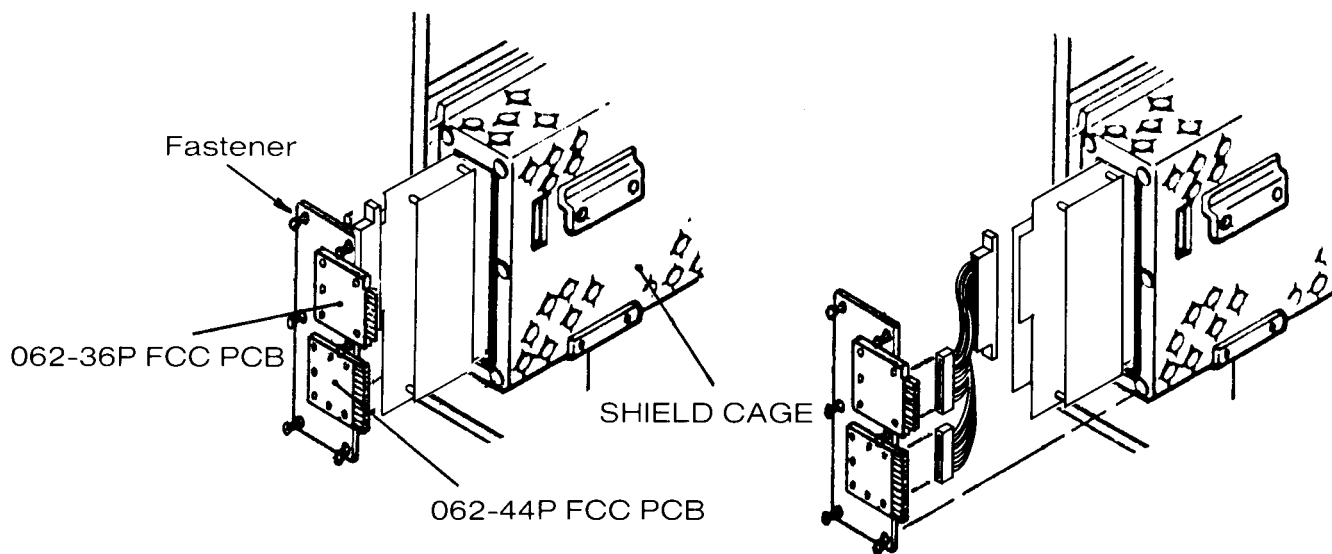

Fig. 7

E. Game PCB Removal

- (1) Make sure the game is unplugged!!
- (2) Open the rear door panel.
- (3) Remove the 36 pin and 44 pin edge connectors from the right side of the FCC-PCBs on the shield cover.
- (4) Pull out the 6 fasteners located on the perimeter of the shield cover.
See Fig. 8
- (5) Remove the 56 pin FCC short harnesses from the game P.C. board.
- (6) Remove the game PCB from the shield cage by carefully sliding it straight out of the wooden PCB guides.



WARNING

A reversed connector will damage your PCB! If the connectors don't slip on easily, don't force them!

IV. RADIO FREQUENCY INTERFERENCE

In order to protect against the RFI radiated from this equipment, please comply with the following.

- (A) Do not use non-Nintendo parts!
- (B) Do not modify your game circuitry!
- (C) Do not modify the wiring harness and connections!
- (D) Connect this game only to a grounded 3-wire outlet.
- (E) After servicing the Game PCB, shut the Shield Cover completely with the Fasteners. See Fig. 8.



56P

1	GND	BROWN	1
A	GND	RED	2
2	GND	GREEN	5
B	GND	BLUE	6
3	+5V	PURPLE	7
C	+5V	GRAY	8
4	+5V	WHITE	9
D	+5V	BLACK	10
E	+12V	BROWN	11
F	+12V	RED	12
16	COIN-1	ORANGE	13
T	COIN-2	GREEN	14
12	RED	PURPLE	15
N	GREEN	WHITE	16
14	VIDEO GND	BROWN	17
13	BLUE	ORANGE	18
P	SYNC	GREEN	19
8	COUNTER	BLACK	20
R	SERVICE	RED	21
10	SOUND	YELLOW	22
L	GND	BLUE	23
27	GND	ORANGE	24
EE	GND	YELLOW	25
21	1P RIGHT	GREEN	26
20	1P LEFT	PURPLE	27
18	1P UP	WHITE	28
19	1P DOWN	BROWN	29
22	1P SW-A	ORANGE	30
23	1P SW-B	GREEN	31
17	1PLAY	PURPLE	32
U	2PLAY	BROWN	33
Y	2P RIGHT	GREEN	34
X	2P LEFT	PURPLE	35
V	2P UP	WHITE	36
W	2P DOWN	BROWN	37
Z	2P SW-A	ORANGE	38
AA	2P SW-B	GREEN	
28	GND	PURPLE	
FF	GND	GRAY	

062 44P FCC PCB

1	1
2	2
3	3
4	4
5	5
6	6
7	7
8	8
9	9
10	10
11	11
12	12
13	13
14	14
15	15
16	16
17	17
18	18
19	19
20	20
21	21
22	22
23	23
24	24
25	25
26	26
27	27
28	28
29	29
30	30
31	31
32	32
33	33
34	34
35	35
36	36
37	37
38	38

062 36P FCC PCB

3	1
4	A
5	B
6	C
7	D
8	E
9	F
10	G
11	H
12	I
13	J
14	K
15	L
16	M
17	N
18	O
19	P
20	Q
21	R
22	S
23	T
24	U
25	V
26	
27	
28	
29	
30	
31	
32	
33	
34	
35	
36	
37	
38	

WIRING DIAGRAM

SCALE: _____ APPROVED BY: _____
 DATE: 9/25/87 REVISION: _____

R-TYPE 56P FCC HARNESS

Nintendo of America Inc.

44P HARNESS

36P HARNESS

11-2-88 PRINTED ON 80% RECYCLED PAPER

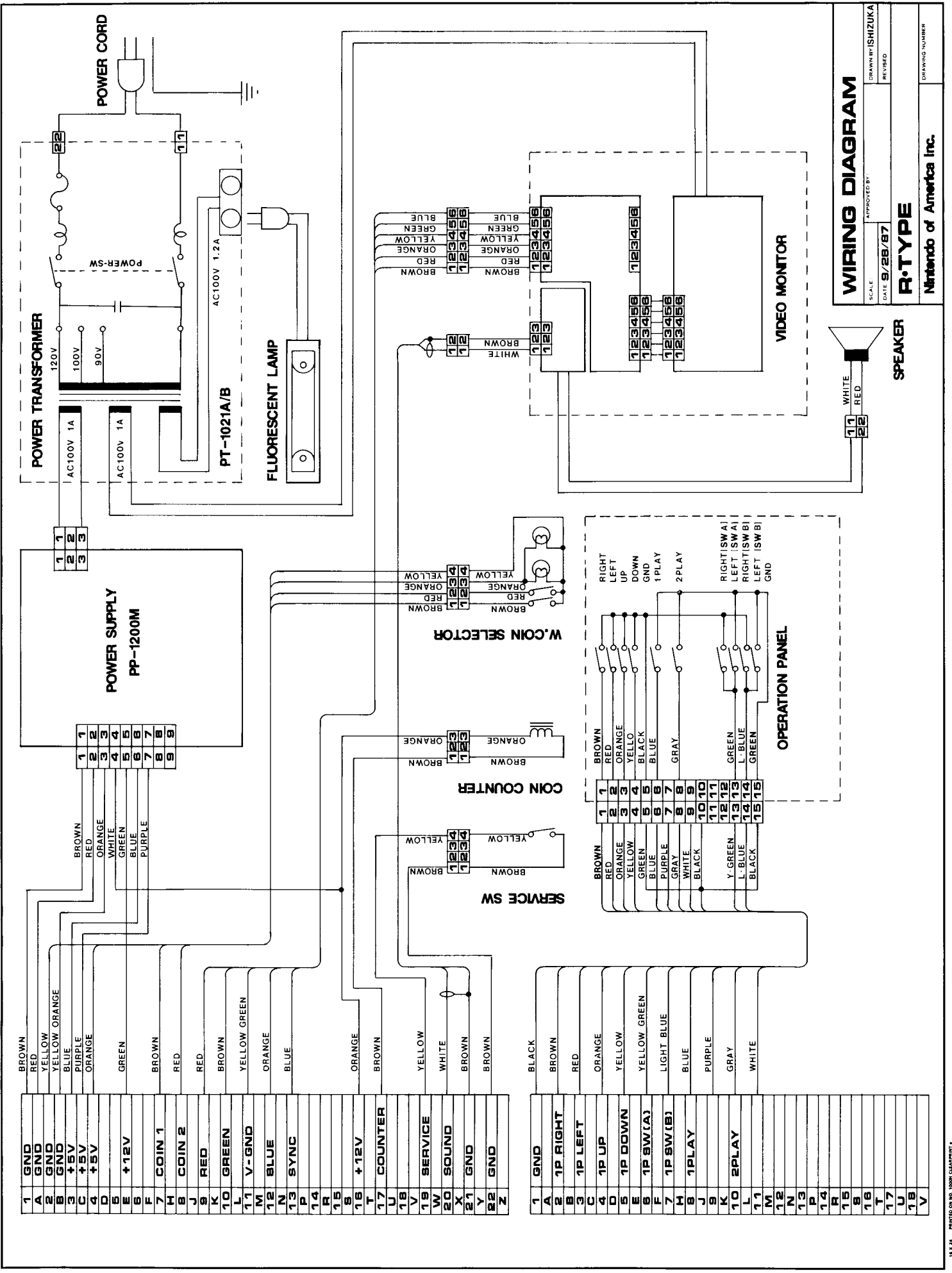

WIRING DIAGRAM

APPROVED BY: _____
 SCALE: _____
 DATE: 9/28/87
 REVISED: _____

R-TYPE

Nintendo of America Inc.

DRAWING NUMBER: _____

1	GND
A	GND
2	GND
B	GND
3	+5V
C	+5V
4	+5V
D	BROWN
E	RED
6	YELLOW ORANGE
7	BLUE
8	PURPLE
9	ORANGE
10	GREEN
11	GREEN
12	BROWN
13	RED
14	RED
15	BROWN
16	YELLOW GREEN
17	ORANGE
18	BLUE
19	ORANGE
20	BLUE
21	YELLOW GREEN
22	ORANGE
A	BROWN
B	BROWN
C	YELLOW
D	WHITE
E	BROWN
F	BROWN
G	BROWN
H	BROWN
I	BROWN
J	BROWN
K	BROWN
L	BROWN
M	BROWN
N	BROWN
O	BROWN
P	BROWN
Q	BROWN
R	BROWN
S	BROWN
T	BROWN
U	BROWN
V	BROWN

1	GND
A	1P RIGHT
B	1P LEFT
C	1P UP
D	1P DOWN
E	1P SW(A)
F	1P SW(B)
G	1PLAY
H	1PLAY
I	1PLAY
J	1PLAY
K	1PLAY
L	1PLAY
M	1PLAY
N	1PLAY
O	1PLAY
P	1PLAY
Q	1PLAY
R	1PLAY
S	1PLAY
T	1PLAY
U	1PLAY
V	1PLAY

40P CONNECTOR

36P EDGE CONNECTOR

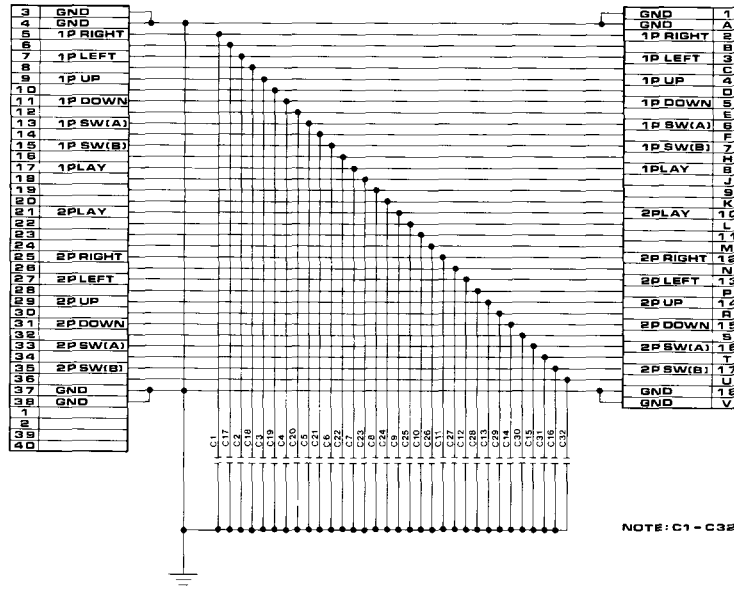

NOTE: C1 - C32 103

SCHEMATIC (R-TYPE)

SCALE	APPROVED BY	DRAWN BY ISHIZUKA
DATE 9/23/87	REV: RED	REV: RED
062 36P FCC PCB		
Nintendo of America Inc.		DRAWING NUMBER

14-111 PRINTED ON RECYCLED PAPER

40P CONNECTOR

44P EDGE CONNECTOR

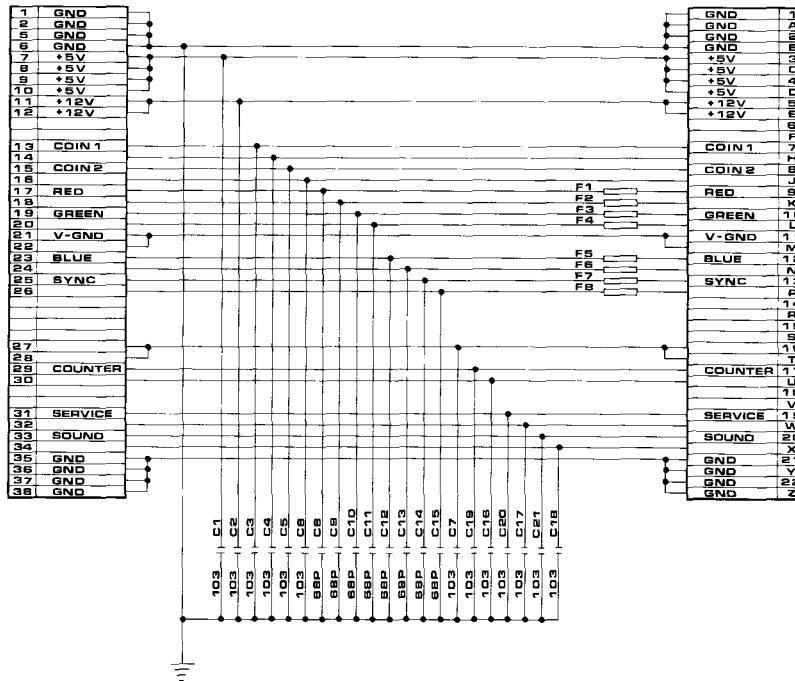

SCHEMATIC (R-TYPE)

SCALE	APPROVED BY	DRAWN BY ISHIZUKA
DATE 9/28/87	REV: RED	REV: RED
062 44P FCC PCB		
Nintendo of America Inc.		DRAWING NUMBER

14-111 PRINTED ON RECYCLED PAPER

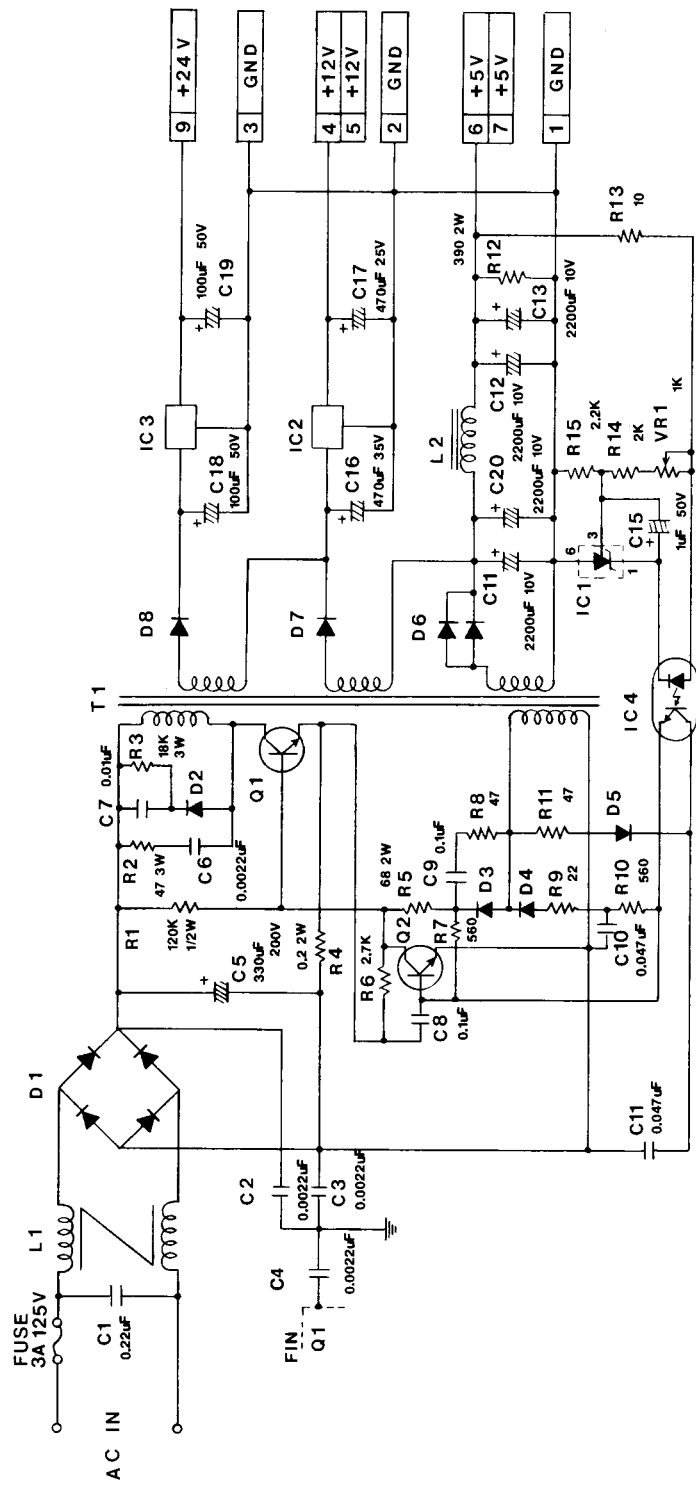

SCHEMATIC (R-TYPE)

SCALE:	APPROVED BY:
DATE: 9 / 17 / 87	DRAWN BY:
	REVISED:

PP-1200M

Nintendo of America Inc.

DRAWING NUMBER

IX. Reorder Parts List

Body Parts — Front View (Fig. 9)

ITEM	PART NO.	DESCRIPTION
1	RTPU-01-01	Body (Black)
2	MGSU-01-49	Speaker Grill
3	MGSU-01-56	Top Trim
4	TKGU-01-29	Fluorescent Lamp Ass'y
5	TKGU-01-29-01	Fluorescent Lamp
6	TKGU-01-29-02	Lamp Starter (Glow Lamp)
7	RTPU-01-24	Name Plate Plexi with Overlay
8	TKGU-01-48	Control Panel Retainer
9	TPPU-01-52	Monitor Support Bar
10	TPPU-01-50	Monitor Mounting Brkt Left
11	TPPU-01-51	Monitor Mounting Brkt Right
12	TKGU-20-00	Video Monitor (20-5F) (Standard Scan)
13	TKGU-20-01	Video Picture Tube
14	TPPU-01-68	Blind Cardboard (Small)
15	MGSU-01-67	Blind Cardboard (Large)
16	MGSA-01-23	Front Screen (Glass)
17	RTPU-23-60	Operation Panel Ass'y
18	TKGU-01-31	Draw Latch
19	TMAU-14-17	Service Door ADD-S2
20	TMAU-14-18	Coin Selector
21	TMAU-34-19	Coin Switch
22	TMAU-14-12	Front Door Lock
23	TMAU-11-27	Cash Box
24	RTPU-01-32	CS Frame 120 W Ass'y 12V
25	RTPU-01-11	Game Counter
26	TKGU-01-33	Service Switch
27	TMAU-11-20	CS Plate 120W (Only)
28	MDSA-01-71	T Molding (Black)
29	TMAU-14-11	Cash Door
30	RTPU-11-23	Side Decal (R-Type)

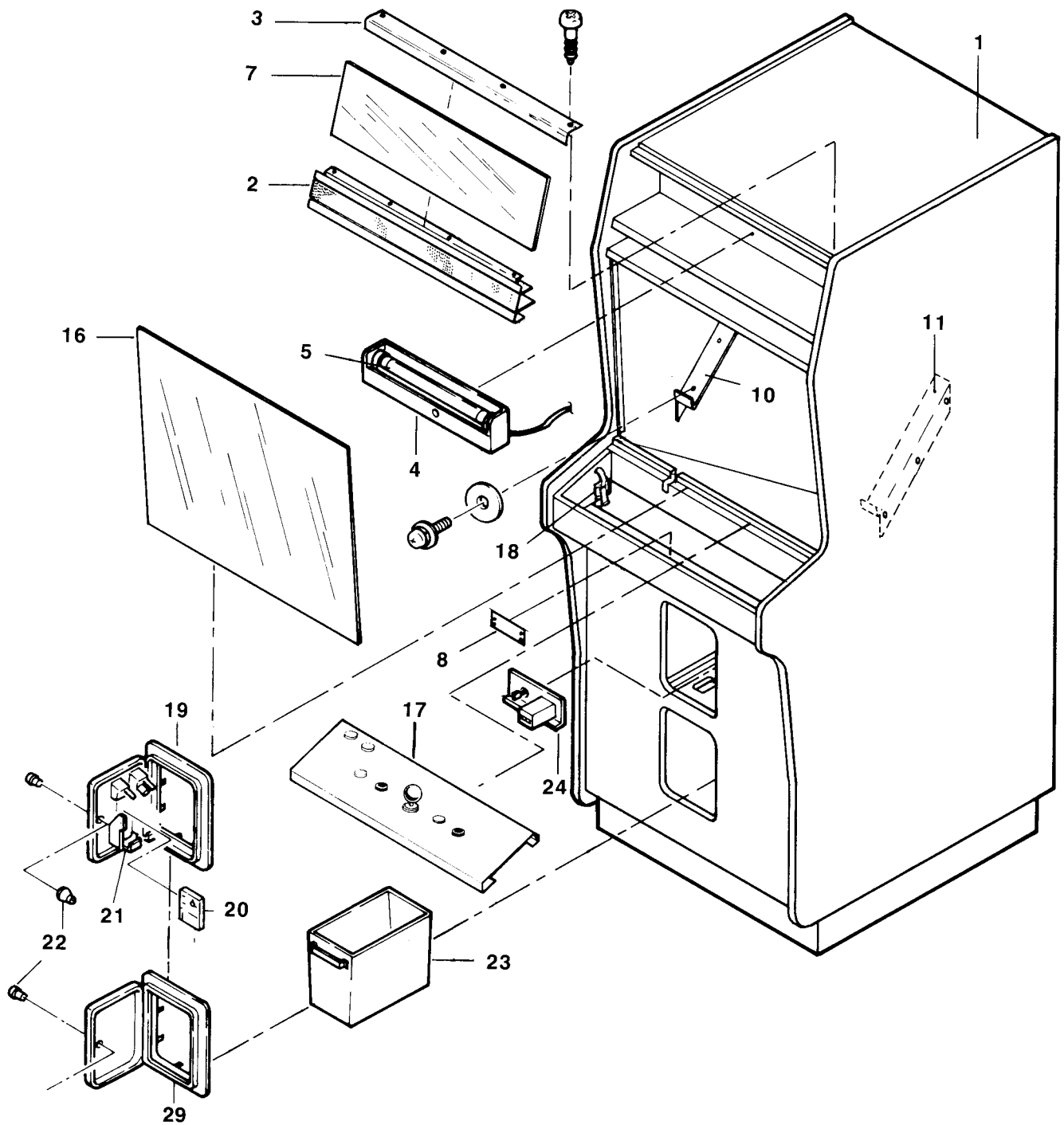

(Fig. 9)

IX. Reorder Parts List, Continued

Body Parts — Rear View (Fig. 10)

ITEM	PART NO.	DESCRIPTION
1	MGSA-01-01-05	Back Door
2	TKGU-01-03	Back Door Lock (Key #6510)
3	TKGU-01-03-01	Back Door Key Only (Key #6510)
4	TKGU-01-05	Cam A-Type (Back Door Lock)
5	RTPU-21-00	P.C. Board Ass'y
6	RTPU-01-01-11	FCC Shield Cover
7	MDSU-01-01-12	062 44P FCC P.C.B. Ass'y
8	MDSU-01-01-13	062 36P FCC P.C.B. Ass'y
9	MDSU-23-35	Snap In Fastener
10	TPPU-01-01-14	FCC Sponge (Black)
11	CHPU-01-01-15	Shield Cover Label
12	TKGU-01-08	Power Cord 5M
13	TKGU-01-10	Strain Relief Bushing
14	TKGU-01-65	Strain Relief Bushing Plate
15	TKGU-11-08	Fuse 5A 125V
16	TKGU-01-30	Caster
17	RTPU-01-01-10	Shield Cage
18	MDSU-08-00	Power Supply PP-1200 M
19	CHPU-08-01	Power Transformer PT1021A or B
20	TKGU-01-07	Back Door Lock Stopper Plate
21	RTPU-11-05	Back Door Label
22	TPPU-11-25	FCC Label
23	TKGU-11-17	Monitor Adjustment Label
24	RTPU-23-61	Operation Manual (R-Type)
25	MGSA-01-67	Blind Cardboard (Large)
26	TPPU-01-68	Blind Cardboard (Small)
27	TKGU-20-00	Video Monitor (20-EZV) (Standard Scan)
28	TKGU-20-01	Video Picture Tube
29	TKGU-10-43	Speaker 16 CM 8 OHM

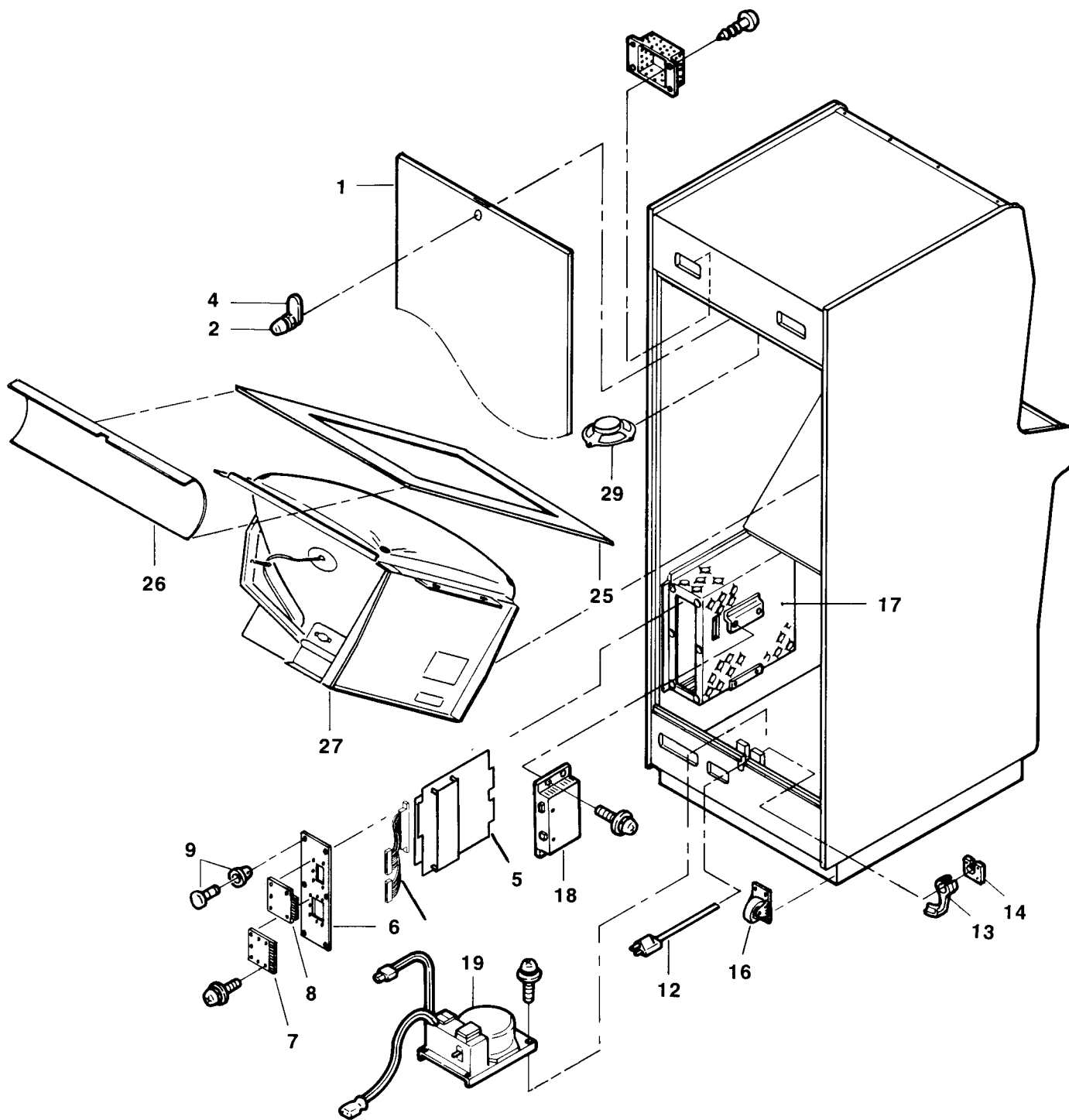
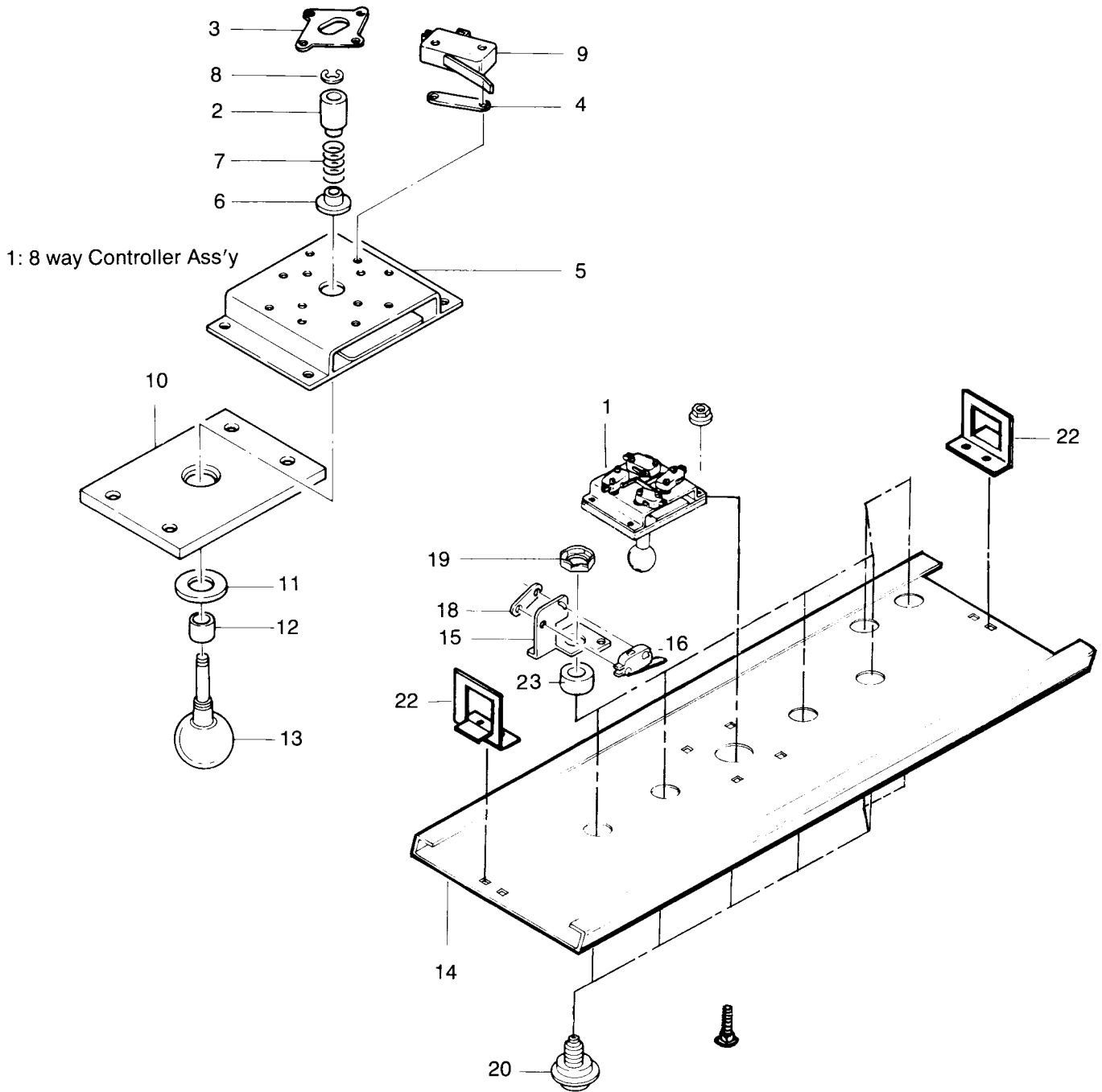

Fig. 10

Operation Panel Assembly (Fig. 11)

ITEM	PART NO.	DESCRIPTION
1	MDST-14-12	8 Way Control Lever Assembly
2	TKGU-23-21	Switch Collar
3	TNX-23-18	8 Way Guide Plate
4	TKGU-23-17	Switch Spacer
5	TKGU-23-16	Bearing Brkt
6	TKGU-23-20	Spring Stopper
7	TKGU-23-22	Lever Spring
8	TKGU-23-23	E-Ring
9	TKGU-23-13	Micro Switch
10	TMAU-12-15	Lever Plate
11	TMAU-12-14	Control Knob Plate
12	TMAU-12-16	Control Knob Collar 8L
13	TMAU-11-18	Knob with Shaft 80.5L
14	RTPU-01-22	Operation Panel Base
15	TKGU-23-12	Switch Button Bracket
16	TMAU-34-18	Micro Switch VL 12L (Straight)
17	MDSU-12-17	Black Sponge, 2 x 10 x 580L
18	TKGU-23-26	Nut Plate
19	TKGU-23-34	Pal Nut M16
20	MDST-12-21	Button Assembly (Black)
21	MDST-12-17	Button Assembly (Crimson)
22	TMAK-11-19	Operation Panel Fastener
23	TMAU-12-18	Collar — 34 x 28 x 7H
24	MDST-12-24	Button Assembly (Light Blue)
25	MDST-12-27	Button Assembly (Green)

VS. UniSystem Operation Panel Assembly Parts (Upright)



(Fig. 11)

Operation Panel Assembly

Wiring Harnesses

PART NO.	DESCRIPTION
RTPU-41-11	56P FCC Harness
RTPU-41-13	UP-072R-44P Edge Harness
MGSU-41-14	UP-072-36P Edge Harness
RTPU-42-11	15P Switch Harness
TPPU-93-07	6P-600 Video Harness
TPPU-93-02	2P-400 Audio Harness
TMAU-41-13	48-800 Service Switch Harness
TMAU-41-14	4P-600 Coin Sw.Harness
TMAU-41-12	3P-500 Counter Harness
TKGU-13-17	2P-860 Speaker Harness

M72 A-C PC Board

ITEM	PART NO.	DESCRIPTION
CHPU-22-42	74LS174, IC1	TTL
CHPU-22-44	74LS244, IC4-8, IC16-17, IC31, IC42, IC72	TTL
MDST-21-28	74LS373, IC13, IC33, IC44	TTL
MDST-21-27	74LS245, IC14-15, IC18, IC34, IC41, IC46	TTL
RTPU-22-01	74ALS374, IC25-28	TTL
RTPU-22-02	74ALS08, IC29, IC40	TTL
CHPU-21-43	74LS374, IC30	TTL
CHPU-21-29	74LS08, IC47	TTL
MDST-21-23	74LS138, IC51	TTL
CHPU-21-27	74L02, IC52	TTL
CHPU-22-08	74LS86, IC57	TTL
MDST-21-18	74S04, IC58	TTL
RTPU-22-03	74ALS00, IC59	TTL
RTPU-22-04	74ALS74, IC60	TTL
MDST-21-21	74LS74, IC61, IC69	TTL
MDST-21-20	74LS32, IC63	TTL
CHPU-21-42	74LS367, IC64	TTL
RTPU-22-05	74LS38, IC67	TTL
CHPU-21-35	74LS139, IC68	TTL
RTPU-22-06	74S158, IC77	TTL
RTPU-22-07	TMM2016BP-10, IC21-22	RAM
RTPU-22-00	TMM2018D-55, IC23-24	RAM
RTPU-22-09	TMM2018D-35, IC36-39	RAM
RTPU-22-10	uPD43256C-10L, IC70-71	RAM
CHPU-21-11	D780C-1/Z80A, IC53	
RTPU-22-11	M51202TL, IC55	Comparator
RTPU-22-12	uPD70116C-8, IC56	
RTPU-22-13	uPD71011C, IC65	
RTPU-22-14	uPD71088C, IC73	
RTPU-22-15	uPD71059C, IC74	
RTPU-22-16	NJM 064D, IC102	
RTPU-22-17	YM-3014, IC103	
RTPU-22-18	YM-2151, IC104	
RTPU-22-19	PAL16L8ACN/TIB PAL 16L8-25CN, IC11	PAL
RTPU-22-20	PAL16L8ACN/TIB PAL 16L8-25CN, IC19	PAL
RTPU-22-21	TBP24S10, IC66	PROM
RTPU-22-22	TBP24S10, IC75	PROM
RTPU-22-23	KNA71H010 (No. 15), IC2	Custom
RTPU-22-24	KNA72H010 (No. 14), IC9	Custom
RTPU-22-25	KNA72H009 (No. 13), IC10	Custom
RTPU-22-26	KNA70H016 (No. 12), IC35	Custom
RTPU-22-27	KNA65005-17, IC62	Custom
RTPU-22-28	KNA70H015 (No. 11), IC76	
RTPU-22-29	KNA91H014, IC79	Custom
CHPU-24-27	470 ohm 1/4w. R1-4, R9-10, R20	Carbon
MDST-32-61	220 ohm 1/4w. R5	Carbon

ITEM	PART NO.	DESCRIPTION
MDST-21-48	4.7k ohm 1/4w, R6-7, R19, R102-194	Carbon
MDST-21-44	1k ohm 1/4w R8, R13-14, R101	Carbon
TKG-56-46	22k ohm 1/4w, R11	Carbon
MDST-21-49	10k ohm 1/4w, R12, R15	
MGSP-08-16	18k 1/4w, R20-22	
RTPU-22-30	1HR-8-472JA, RA1-2, RA12	R-Network
RTPU-22-31	RGLD8M472J221J, RA3-8	R-Network
RTPU-22-32	1HR-8-103JA, RA9	R-Network
RTPU-22-33	1HR-8-102JA, RA10-11	R-Network
RTPU-22-34	RGSD10L471G, RA13-15	R-Network
RTPU-22-35	VZ103KSL2-50k ohm, VR1	Variable Resistor
MDST-21-67	0.1 mfd 12v, C1-22, C25, C27, C31-96, C114, C116	Ceramic
MDST-21-72	47 mfd 16v, C23, C26, C105	Electrolytic
MDST-21-71	10 mfd 16v, C24	Electrolytic
RTPU-22-36	390 pfd 50v, C28, C97	Ceramic
TUB-08-21	2200 mfd 16v, C101-102	Electrolytic
RTPU-22-37	.15 mfd 50v, C103	Polyester
TKG-08-27	470 mfd 25v, C104	Electrolytic
RTPU-22-38	.01 mfd 50v, C106	Polyester
RTPU-22-39	.001 mfd 50v, C107	Polyester
TMAU-21-90	1 mfd 25v, C108	Electrolytic
MDST-21-46	2.2k ohm 1/4w, C109	Carbon Resistor
RTPU-22-40	6800 pfd 50v, C110	Polyester
RTPU-22-41	1200 ofd 50v, C111	Polyester
RTPU-22-42	3300 pfd 50v, C112	Polyester
MON-09-55	100 mfd 25v, C113	Electrolytic
TMAU-21-98	10 mfd 25v, C115	Tantalum
MDST-21-65	220 pfd 50v, IC47 Pins 7-8	Ceramic
RTPU-22-43	DSS310-55B-101M, LC1-4	EMI Filter
RTPU-22-24	1S5277B, D1-2	Diode
TPP-08-11	1S1588, D3-4	Diode
RTPU-22-45	2SC2120, TR1-2	Transistor
CHPU-21-50	2SC1815, TR3	Transistor
RTPU-22-46	KSD-08, SW1-2	Dip Switch
RTPU-22-47	3.58 mhz, X1	Xtal
RTPU-22-48	32 mhz, X2	Xtal
TMAU-21-104	20-Pin Socket, IC11, IC19	Socket
MDST-21-82	40-Pin Socket, IC53, IC56	Socket
CHPU-21-58	16-Pin Socket, IC66, IC75	Socket
RTPU-22-49	XG3A-6014, CN1-2	Connector
RTPU-22-50	XC5E-5021, CN3	Connector
RTPU-22-51	XC5E-6421/XC2E-6411, CN4	Connector
RTOU-22-52	B3PS-VH, CN5	Base Post

M72 B-D PC Board

ITEM	PART NO.	DESCRIPTION
CHPU-21-27	74LS02, IC1	TTL
CHPU-22-08	74LS86, IC2, IC50, IC57, IC80-81, IC84-85	TTL
CHPU-22-43	74LS1875, IC4, IC7, IC60, IC65	TTL
RTPU-23-01	74LS166, IC5-6, IC13-14	TTL
MDST-21-21	74LS74, IC10-11, IC41, IC48, IC83	TTL
MDST-21-24	74LS157, IC12, IC15, IC61-64, IC71-74	TTL
CHPU-22-34	74LS20, IC16-17	TTL
MDST-21-27	74LS00, IC18, IC28	TTL
CHPU-22-42	74LS174, IC19, IC29, IC31, IC38, IC70, IC75	TTL
CHPU-22-45	74LS273, IC30, IC32, IC37, IC39, IC42, IC47, IC58-59, IC66-67	TTL
MDST-21-23	74LS138, IC40, IC49	TTL
CHPU-21-43	74LS374, IC43, IC46, IC53-54	TTL
CHPU-22-44	74LS244, IC44-45, IC53, IC55	TTL
MDST-21-20	74LS32, IC51, IC56	TTL
CHPU-22-46	74LS283, IC68-69, IC76-79, IC86-87	TTL
MDST-21-19	74LS10, IC82	TTL
CHPU-21-42	74LS367, IC88	TTL
RTPU-23-02	uPD4364CX-10L, IC33-36	RAM
RTPU-23-03	KNA604201 (No. 6), IC3, IC8	Custom
RTPU-23-19	KNA91H014	Custom
RTPU-23-04	27256, IC20	EPROM
RPU-23-05	27256, IC21	EPROM
RTPU-23-06	27256, IC22	EPROM
RTPU-23-07	27256, IC23	EPROM
RTPU-23-08	27256, IC24	EPROM
RTPU-23-09	27256, IC25	EPROM
RTPU-23-10	27256, IC26	EPROM
RTPU-23-11	27256, IC27	EPROM
MGSP-08-16	18k ohm 1/4w, R1-4	Resistor
RTPU-23-12	RGSD10L471G, RA1-3	R-Network
RTPU-23-13	390 pfd 50v, C1-2	Ceramic
MDST-21-67	0.1 mfd 12v, C3-81	Ceramic
RTPU-23-14	100 pfd 50v, C93	Ceramic
RTPU-23-15	32-Pin Socket, IC20-27	Socket
RTPU-23-16	XG3A-6014, CN1-2	Connector
RTPU-23-17	IMSA-9202-H, J2-5	Short Pin
RTPU-23-18	IMSA-9202B-1.3, J2-5	Short Base

M72 ROM-C PC Board

ITEM	PART NO.	DESCRIPTION
MDST-21-27	74LS245, 1A, 2A	TTL
RTPU-21-01	uPD 4364CX-10L, 1F, 3F	RAM
RTPU-21-02	27512, 1B	EPROM
RTPU-21-03	27512, 1C	EPROM
RTPU-21-04	27512, 1H	EPROM
RTPU-21-05	27512, 1K	EPROM
RTPU-21-06	27512, 3B	EPROM
RTPU-21-07	27512, 3C	EPROM
RTPU-21-08	27512, 3H	EPROM
RTPU-21-09	27512, 3K	EPROM
RTPU-21-10	27256, 1J	EPROM
RTPU-21-11	27256, 1L	EPROM
RTPU-21-12	27256, 3J	EPROM
RTPU-21-13	27256, 3L	EPROM
RTPU-21-14	PAL 16L8ACN, 7N	PAL
RTPU-21-15	1HR-8-103JA	R-Network
MDST-21-67	0.1 mfd 12v, C1-21	Ceramic
RTPU-21-16	32 Pin Socket, 1B-L, 3B-L	Socket
RTPU-21-17	20 Pin Socket, 3A	Socket
RTPU-21-18	XC5B-5021, CN3	Connector
RTPU-21-19	XC5B-6421/XC2B-6411, CN4	Connector
RTPU-21-20	IMSA-9202H, J1-2	Short Pin
RTPU-21-21	IMSA-9202B-1.3, J1-2	Short Base

PP-1200M Power Supply

ITEM	PART NO.	DESCRIPTION
RTPU-08-01	2SC3317, Q1	Transistor
RTPU-08-02	2SC2235, Q2	Transistor
RTPU-08-03	KBL-02, D1	Diode Bridge
MDST-32-17	ERB 44-04, D2	Fast Recovery Diode
MDST-32-16	ERB 44-02, D8	Fast Recovery Diode
RTPU-08-04	1S592, D3	Diode
TKG-08-15	1S1588, D4-5	Diode
MDST-32-18	ESAC82-004, D6	Schottky Diode
RTPU-08-05	ERB81-004, D7	Schottky Diode
RTPU-08-06	IR9431, IC1	Shunt Regulator
RTPU-08-07	TA78012AP, IC2	Regulator
RTPU-08-08	TA78024AP, IC3	Regulator
RTPU-08-09	PC817, IC4	Photo Coupler
RTPU-08-10	PLA1021A, L1	Coil
RTPU-08-11	Coil, L2	Coil
RTPU-08-12	2200 pfd 125v, C2-4	Ceramic
MDST-32-37	2200 pfd 400v, C6	Polyester
MDST-32-35	.01 mfd 400v, C7	Polyester
MDST-32-31	.1 mfd 50v, C8-9	Polyester
RTPU-08-13	.047 mfd 50v, C10-11	Polyester
MDST-32-36	.22 mfd 125v, C1	Metallized Polyester
RTPU-08-14	330 mfd 200v, C5	Electrolytic
RTPU-08-15	2200 mfd 10v, C12, C20	Electrolytic
RTPU-08-16	2200 mfd 10v, C13, C14	Electrolytic
RTPU-08-17	1 mfd 50v, C15	Electrolytic
RTPU-08-18	470 mfd 35v, C16	Electrolytic
RTPU-08-19	470 mfd 25v, C17	Electrolytic
RTPU-08-20	100 mfd 50v, C18-19	Electrolytic
RTPU-08-21	18k ohm 3w, R3	Metal Film
RTPU-08-22	68 ohm 2w, R5	Metal Film
RTPU-08-23	390 ohm 2w, R12	Metal Film
RTPU-08-24	47 ohm 3w, R2	Metal Film
MDST-32-43	.2 ohm 2w, R4	Cement
RTPU-08-25	120k ohm 1/2w, R1	Carbon
PCHU-21-98	2.2k ohm 1/4w, R15	Carbon
MDST-32-59	560 ohm 1/4w, R7, R10	Carbon
RTPU-08-26	47 ohm 1/4w, R8, R11	Carbon
CHPU-21-70	10 ohm 1/4w, R13	Carbon
TPP-08-23	22 ohm 1/4w, R9	Carbon
CHPU-24-28	2K ohm 1/4w, R14	Carbon
MDSU-08-28	2.7k ohm 1/4w, R6	Carbon
RTPU-08-26	1k ohm Variable Resistor, VR1	
RTPU-08-27	Transformer 68-0435, T	
RTPU-08-28	Fuse, 3 amp, F1	
RTPU-08-29	3-Pin Power Harness (in)	
RTPU-08-30	9-Pin Power Harness (out)	

XI. Diagnostic Test

To start a diagnostic test, turn the game off and set Dip Switch Number 2, position 8, to ON, then turn the game back on.

The RAM and ROM will automatically be tested upon Power Up. The screen should show "RAM OK" and "ROM OK". If the RAMs are faulty, "RAM NG" and a number (1-6) will be shown. The number will correspond to one of the following:

1. Work RAM (byte check)
2. Work RAM (word check)
3. V-RAM A (word check)
4. V-RAM B (word check)
5. Sound L (byte check) 0000H to 7FFFH
6. Sound H (byte check) 8000H to FFFFH

If the ROMs are defective, "ROM NG" will be shown.

To bring up test menu, press the 1-Player and 2-Player buttons simultaneously. The following test menu will be shown:

I/O
Sound
Character
Color
Cross Hatch

Move the Joystick up or down to select test. Press the Fire button to start each test, and press the 1-Player and 2-Player buttons simultaneously to terminate the test and return to the test menu. The five tests are as follows:

1) I/O Port Test

Tests Joystick, buttons, coin acceptors and displays dip switch settings. Shown on the screen as follows:

	8	7	6	5	4	3	2	1	8	7	6	5	4	3	2	1
In Port 1	0	0	0	0	0	0	0	0	0	0	0	0	0	0	0	0
In Port 2	0	0	0	0	0	0	0	0	0	0	0	0	0	0	0	0
Dip SW	0	0	0	0	0	0	0	0	0	0	0	0	0	0	0	0

(0 - Off, 1 - On)

2) Sound Test

Screen will show number (1-65) and corresponding sound will be heard.

3) Character Test

Four ships will be displayed as shown below:

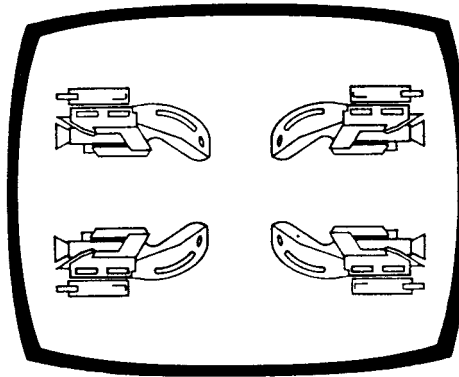

3) Color Test

Move the joystick down to advance the test. The following will be shown:

Entire screen will show blue, then red, magenta, green, cyanic, yellow, white and the following color pattern:

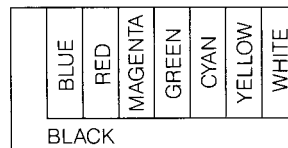

5) Cross Hatch Pattern

A 16-line cross hatch pattern will be shown with 2-dot wide white lines.

Adjustment of Video Monitor

Video Monitor : Type **XM-2001N**

CHASSIS LAYOUT

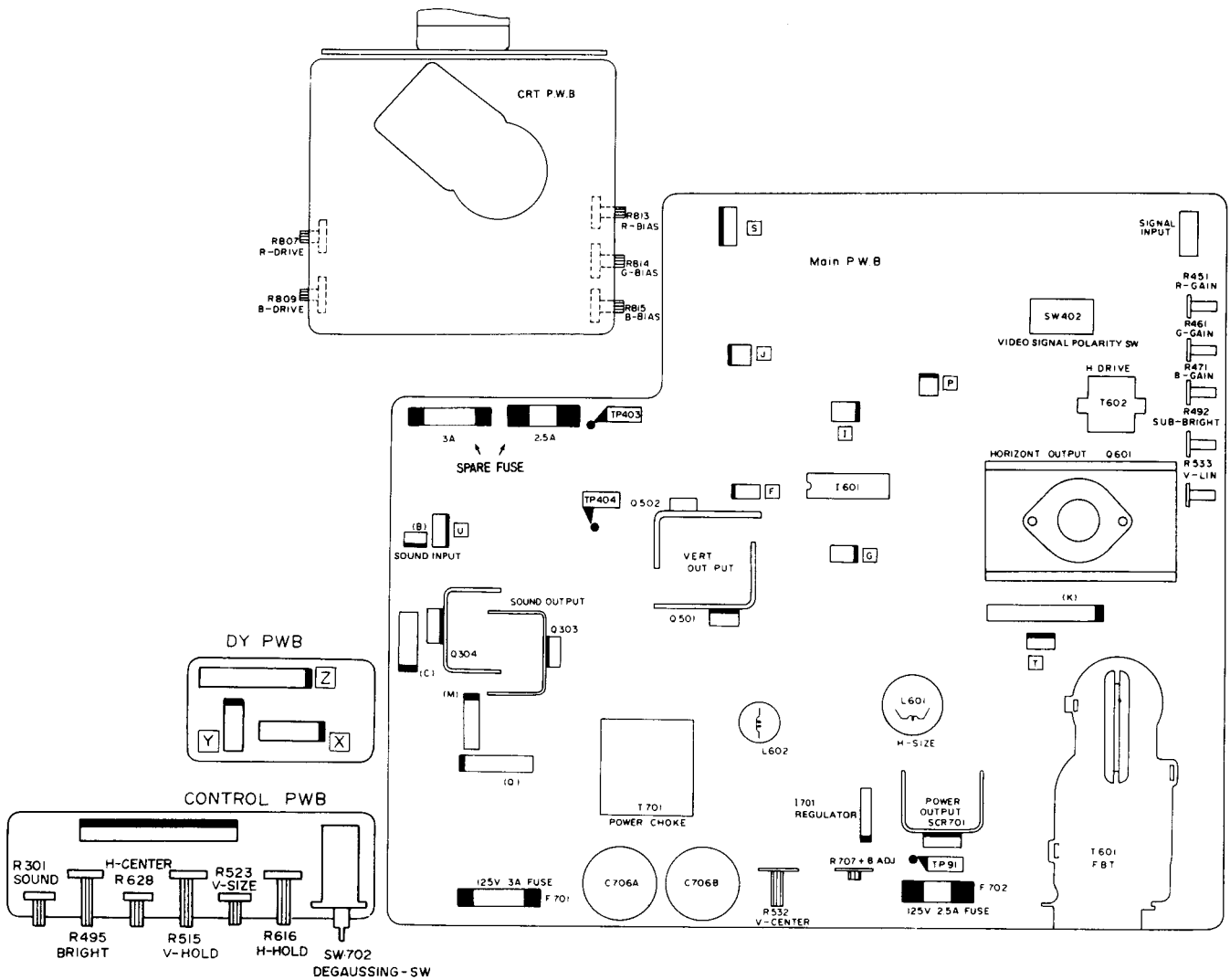

WARNING

The Video Monitor contains HIGH VOLTAGE capable of delivering LETHAL quantities of energy. TO AVOID DANGER TO LIFE, don't attempt to service the chassis until all precautions necessary for working on HIGH VOLTAGE equipment have been observed.

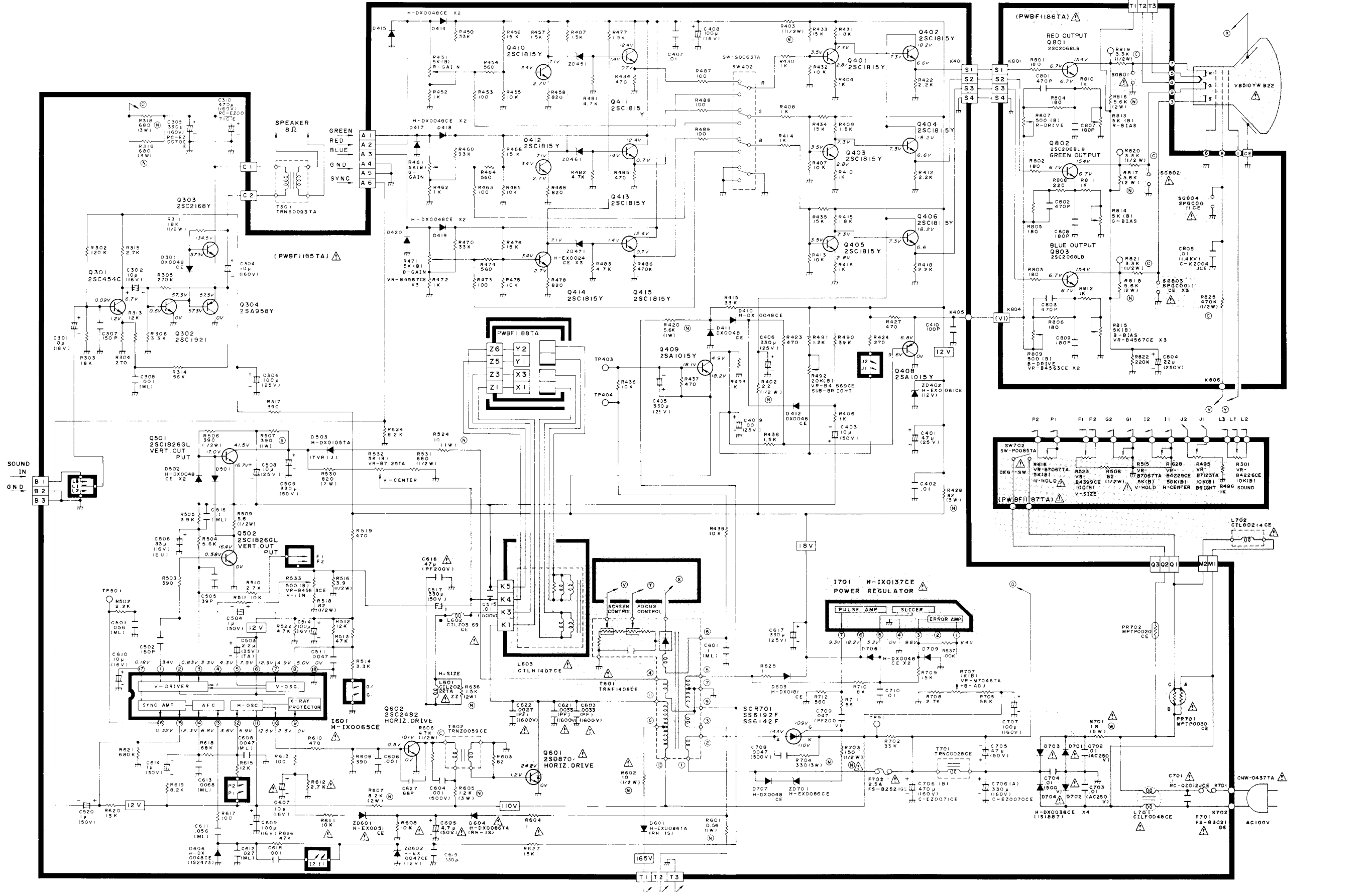

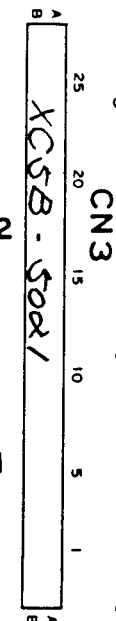
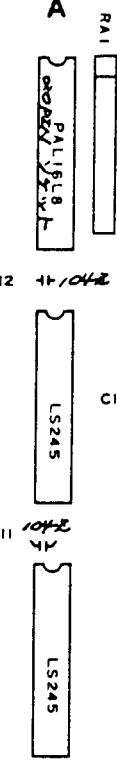
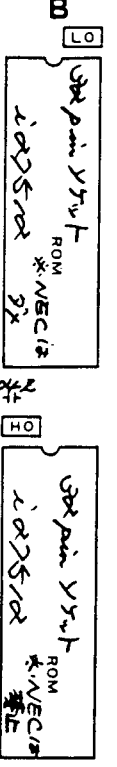
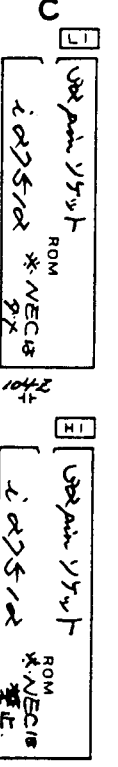
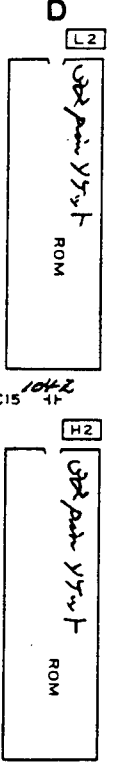
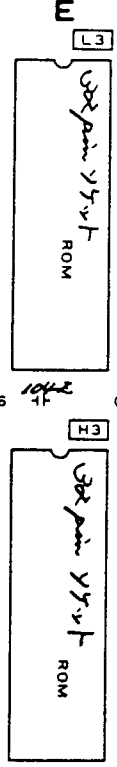
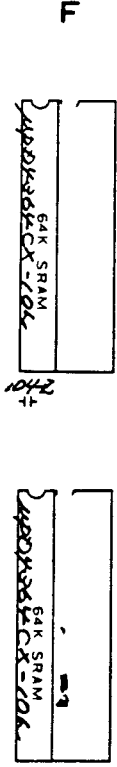
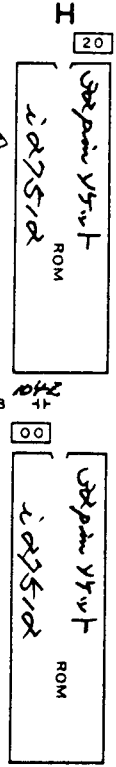
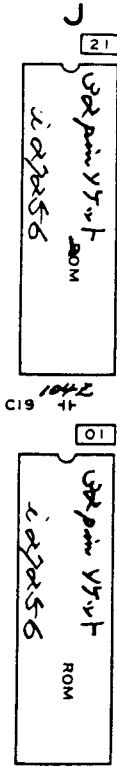
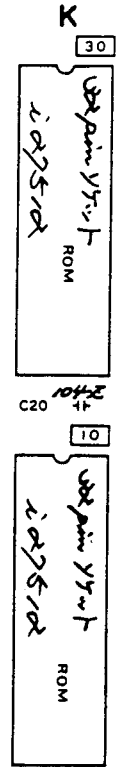
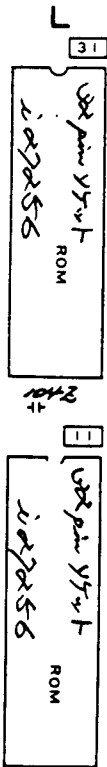
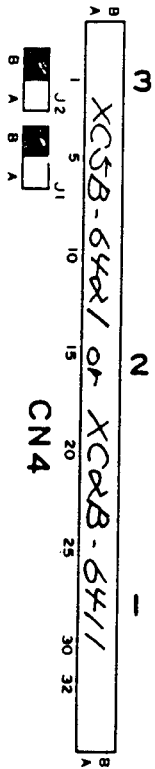

M72-ROM-C

NANAO CORPORATION					TITLE
DATE	DRAWN	CHECKED	DESIGNED	APPROVED	M72-ROM-C P011
62.6.15					DRAW NO.
SCALE					5V00780

部品面 S62. 月 B

① 0.5mm 9x9x9
② 0.5mm 9x9x9

A
B
C
D
E
F
G
H

CN1 60極

A		B
D15	1	D14
D13	2	D12
D11	3	D10
D9	4	D8
D7	5	D6
D5	6	D4
D3	7	D2
D1	8	D0
+5V	9	+5V
A19	10	A18
A17	11	A16
A15	12	A14
A13	13	A12
A11	14	A10
A9	15	A8
A7	16	A6
A5	17	A4
A3	18	A2
A1	19	A0
+5V	20	+5V
UBF	21	M/I0
MRD	22	MWR
IORD	23	TOWR
BUF R/W	24	ASTB
DBEN	25	
WAIT	26	INT4
+5V	27	+5V
+5V	28	+5V
+5V	29	+5V
+5V	30	+5V

CN2 60極

A		B
CHARA	1	GND
CHARAP	2	
CBLK	3	
NL	4	
S24H	5	
POL	6	
PIL	7	
RED	8	
GREEN	9	
BLUE	10	
V 1 E	11	
V 2 E	12	
V 4 E	13	
V 8 E	14	
V 16 E	15	
V 32 E	16	
V 64 E	17	
V128E	18	
V256E	19	
H 1 E	20	
H 2 E	21	
H 4 E	22	
H 8 E	23	
H 16 E	24	
H 32 E	25	
H 64 E	26	
H128E	27	
H256E	28	
H512E	29	
DCKL	30	GND

CN3 50極

A		B
+5V	1	INT3
D15	2	D14
D13	3	D12
D11	4	D10
D9	5	D8
D7	6	D6
D5	7	D4
D3	8	D2
D1	9	D0
SUBWAIT	10	BUSCHANGE
A19	11	A18
A17	12	A16
A15	13	A14
A13	14	A12
A11	15	A10
A9	16	A8
A7	17	A6
A5	18	A4
A3	19	A2
A1	20	A0
UBF	21	BANK
MRD	22	MWR
BUF R/W	23	M/I0
DBEN	24	IORD
GND	25	TOWR

CN4 64極

A		B
+5V	1	+5V
+5V	2	+5V
RH4	3	+5V
COD15	4	COD14
COD13	5	COD12
COD11	6	COD10
COD9	7	COD8
COD7	8	COD6
COD5	9	COD4
COD3D	10	COD2D
COD1D	11	COD0D
RV8	12	RV4
RV2	13	RV1
GND	14	GND
RD37	15	RD36
RD35	16	RD34
RD33	17	RD32
RD31	18	RD30
RD27	19	RD26
RD25	20	RD24
RD23	21	RD22
RD21	22	RD20
RD17	23	RD16
RD15	24	RD14
RD13	25	RD12
RD11	26	RD10
RD07	27	RD06
RD05	28	RD04
RD03	29	RD02
RD01	30	RD00
GND	31	GND
GND	32	GND

DRAWN	CHECKED	DESIGNED	APPROVED	TITLE	MATERIAL CODE	REMARKS
				M72 CONNECTION		
DATE	SCALE	NANO CORPORATION		DRAW NO		
12.09.01	1:1	NANO CORPORATION		7/3		
USED ON				3RD ANGLE PROJECTION		

A
B
C
D
E
F
G
H

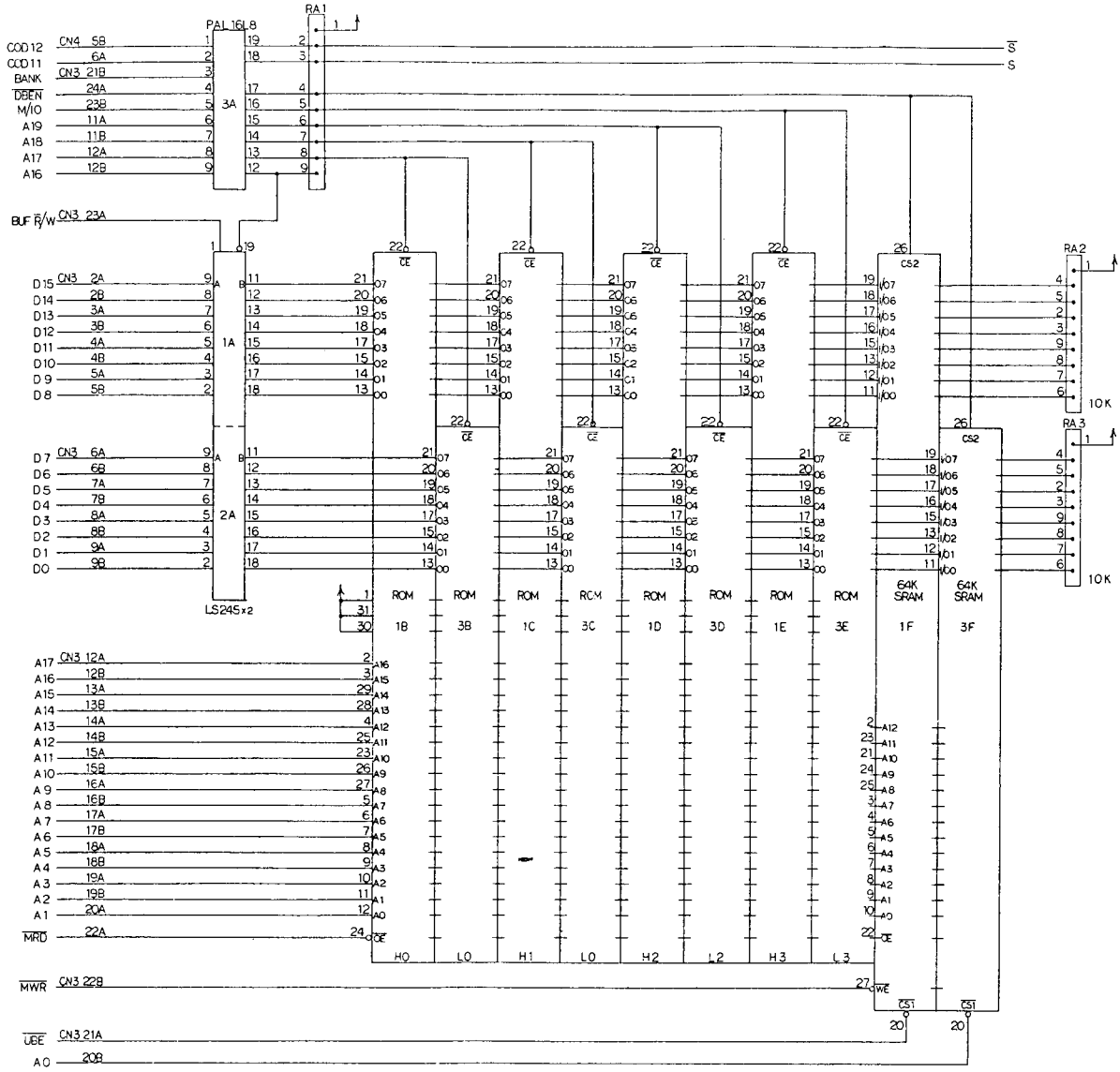

CHANCE	GROUP	RECD / SET	ITEM	DESCRIPTION	MATERIAL	MATERIAL CODE	REMARKS
		<p>NANAO CORPORATION</p> <p>TITLE: M72-ROM-C 1/2</p> <p>DATE: 6/8/77 DRAWN: [Signature] CHECKED: [Signature] DESIGNED: [Signature] APPROVED: [Signature]</p> <p>SCALE: 11.7-1 NTS: [Signature]</p> <p>CRAW NO: [Signature]</p>					
USED ON		3RD ANGLE PROJECTION		DWG IN	SHEET		

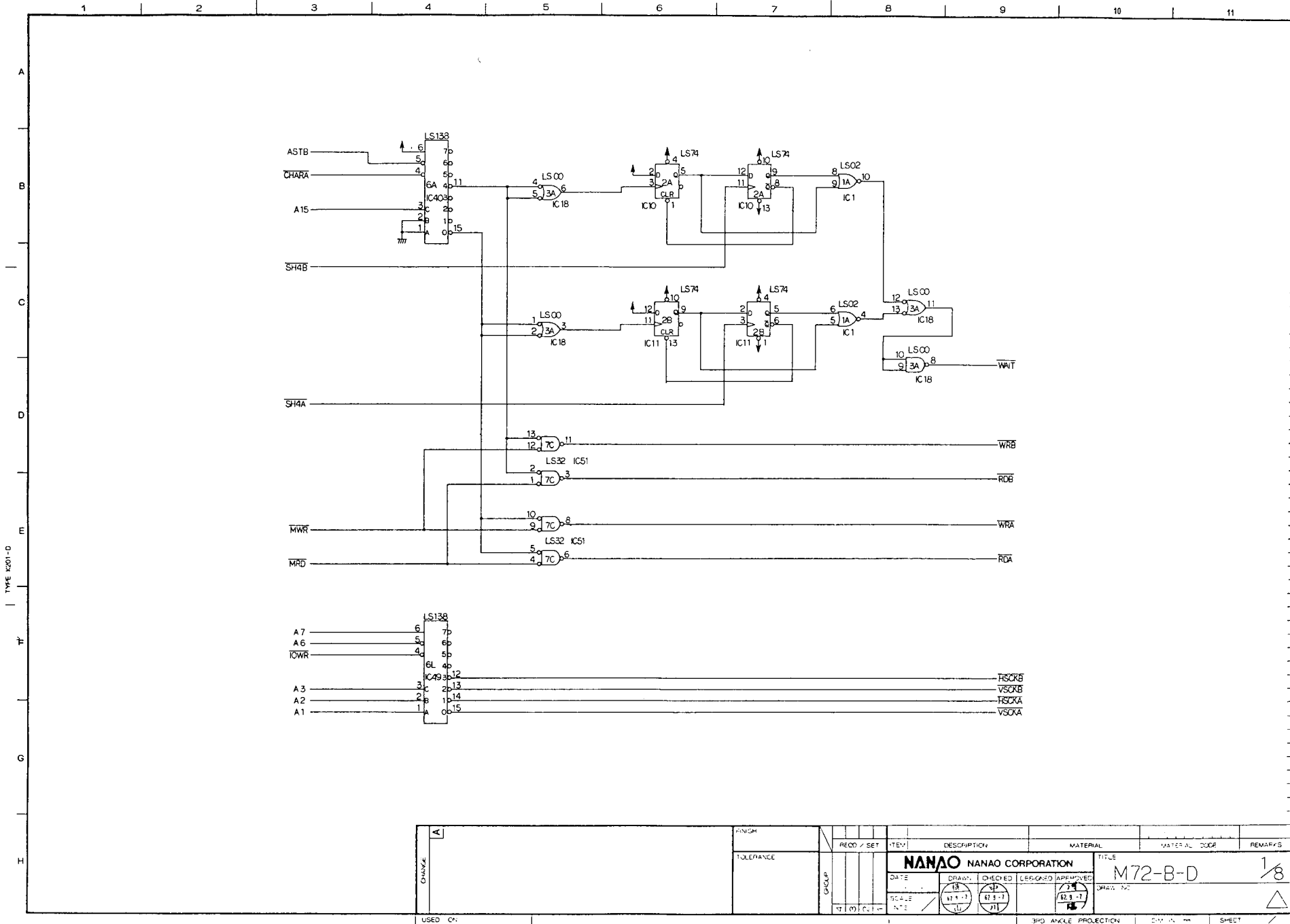

NO.	RECD / SET	ITEM	DESCRIPTION	MATERIAL	MATERIAL QUOTE	REMARKS	
							DATE
NANAO NANAO CORPORATION							
TITLE						M72-B-D	1/8
DATE						18	
SCALE						1:1	
N/A							
3RD ANGLE PROJECTION							
SHEET							

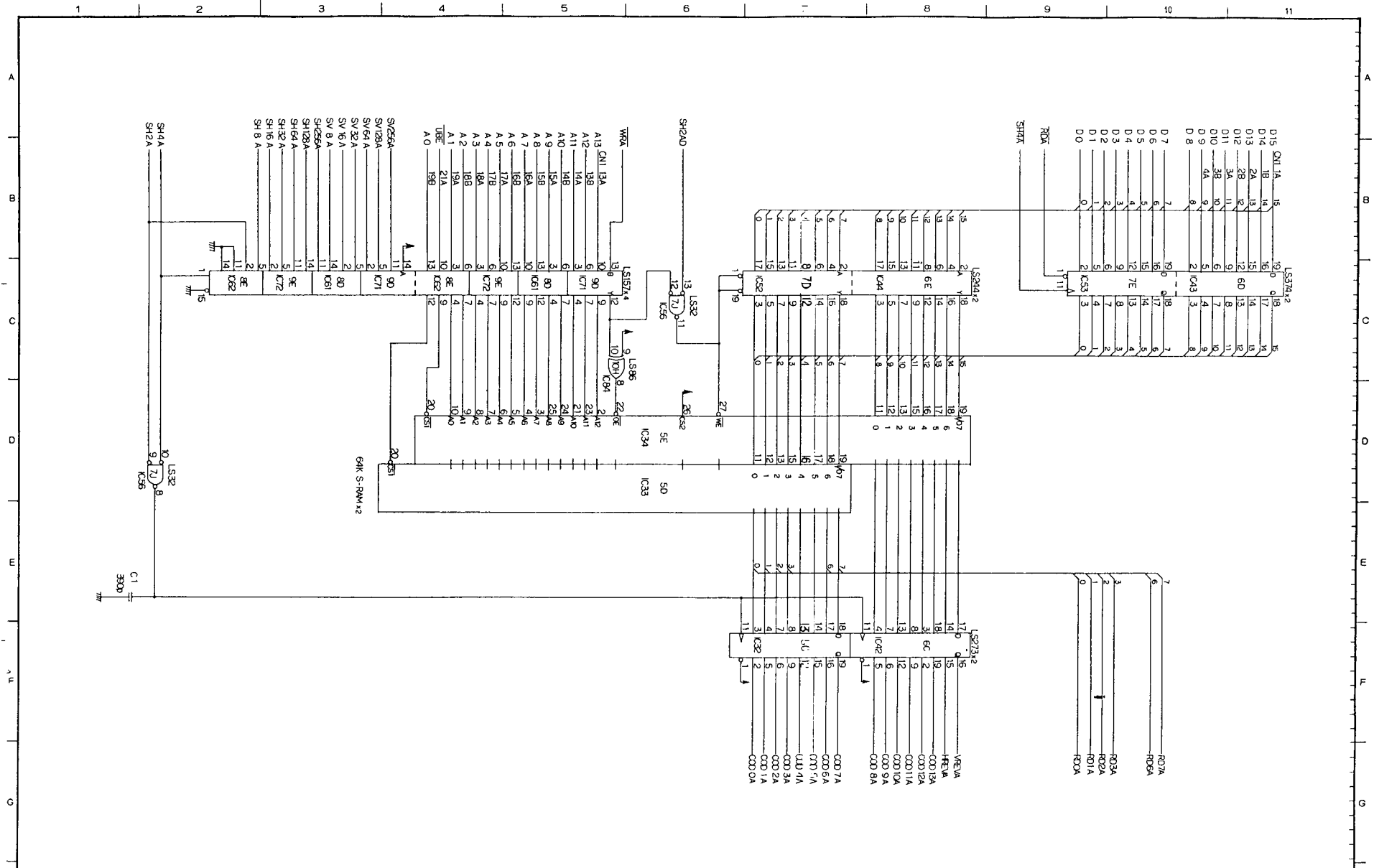

REV	DATE	DESCRIPTION	MATERIAL	MATERIAL CODE	REMARKS
1					
2					
3					
4					
5					
6					
7					
8					
9					
10					
11					
12					
13					
14					
15					
16					
17					
18					
19					
20					
21					
22					
23					
24					
25					
26					
27					
28					
29					
30					
31					
32					
33					
34					
35					
36					
37					
38					
39					
40					
41					
42					
43					
44					
45					
46					
47					
48					
49					
50					
51					
52					
53					
54					
55					
56					
57					
58					
59					
60					
61					
62					
63					
64					
65					
66					
67					
68					
69					
70					
71					
72					
73					
74					
75					
76					
77					
78					
79					
80					
81					
82					
83					
84					
85					
86					
87					
88					
89					
90					
91					
92					
93					
94					
95					
96					
97					
98					
99					
100					

NANAO NANAO CORPORATION

TITLE: M72-B-D

3/8

DATE: 02.9.17
SCALE: 1:1

DRAWN: [Signature]
CHECKED: [Signature]
DESIGNED: [Signature]
APPROVED: [Signature]

3RD ANGLE PROJECTION DIM IN MM SHEET

USED ON: [Blank]

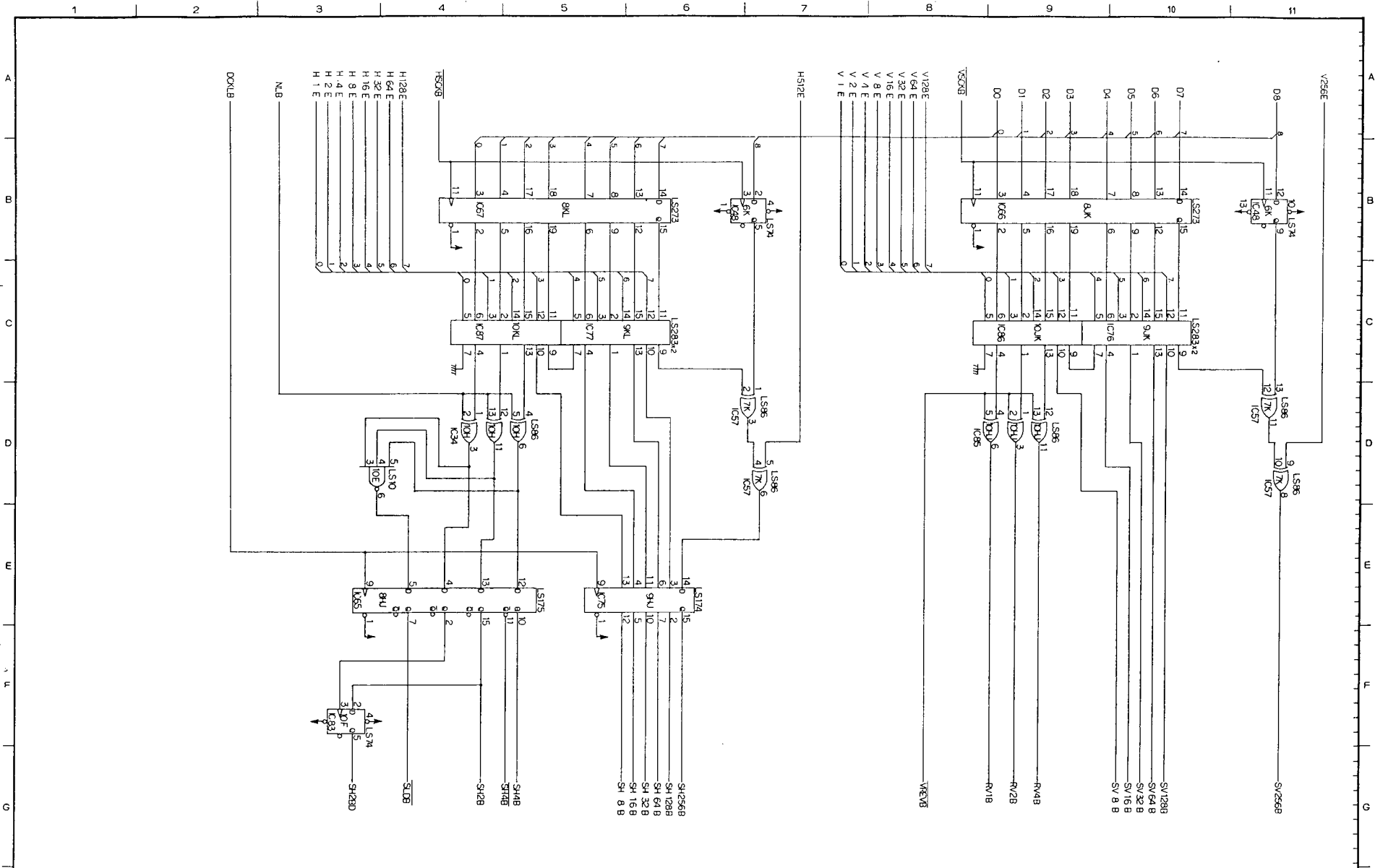

REV	DESCRIPTION	DATE	BY	CHKD	APPROVED	TITLE	MATERIAL CODE	REMARKS
1						M72-B-D		5/8
<p>NANAO CORPORATION</p> <p>DATE: _____ SCALE: _____</p> <p>DRAWN: _____ CHECKED: _____ DESIGNED: _____ APPROVED: _____</p> <p>SCALE: NTS</p>						<p>3RD ANGLE PROJECTION</p> <p>5M IN 1:1</p> <p>SHEET</p>		

USED ON

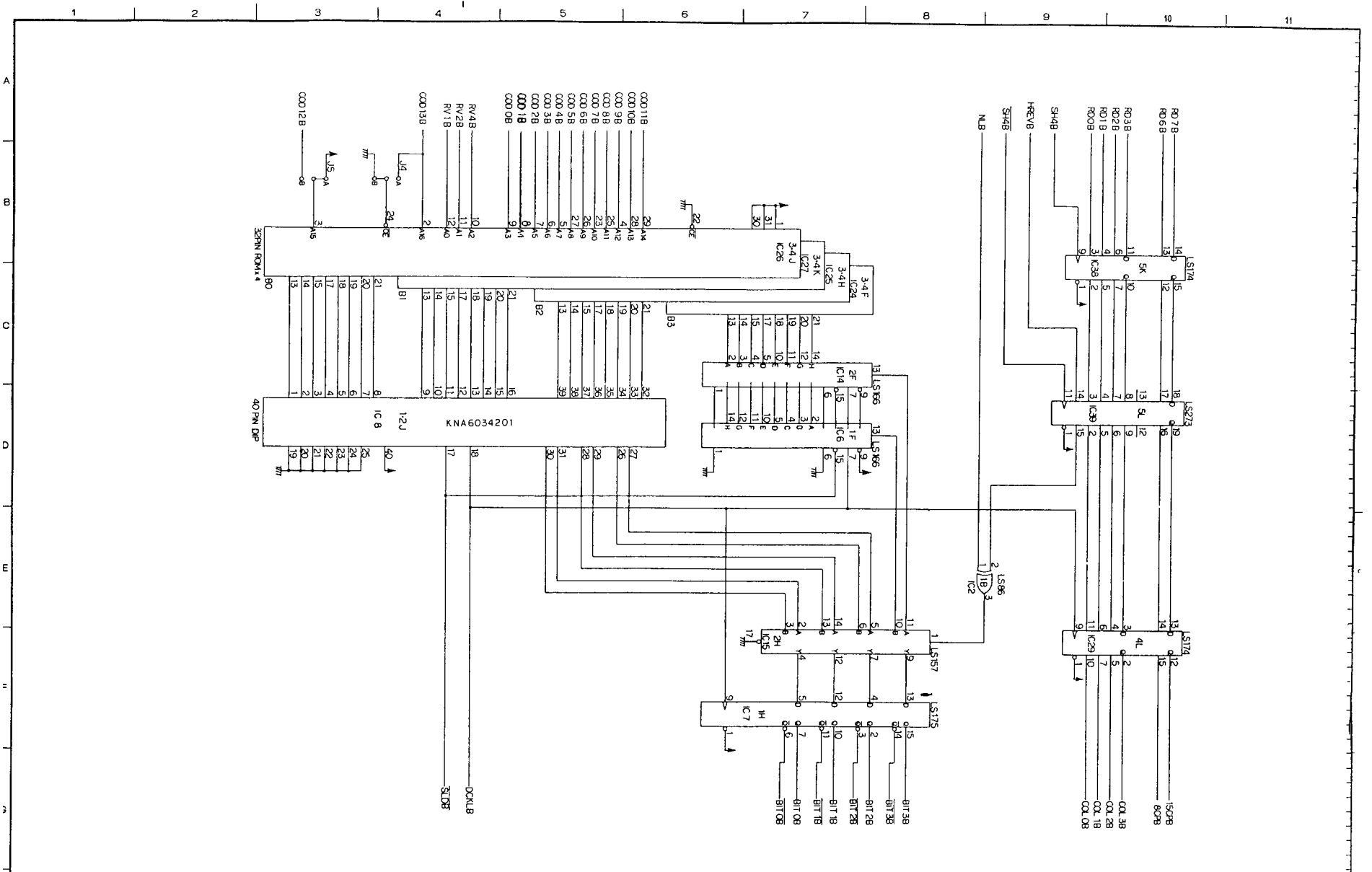

REV	DATE	DESCRIPTION	MATERIAL	MATERIAL QTY	REMARKS
1					

NANAO CORPORATION DATE: 82.9.17 SCALE: 1:1 NTS: 1/1		TITLE: M72-B-D DRAWN: JC DESIGNED: JC CHECKED: JC APPROVED: JC		7/8 1/1
---	--	--	--	------------

3RD ANGLE PROJECTION	DM IN.	SHEET
----------------------	--------	-------

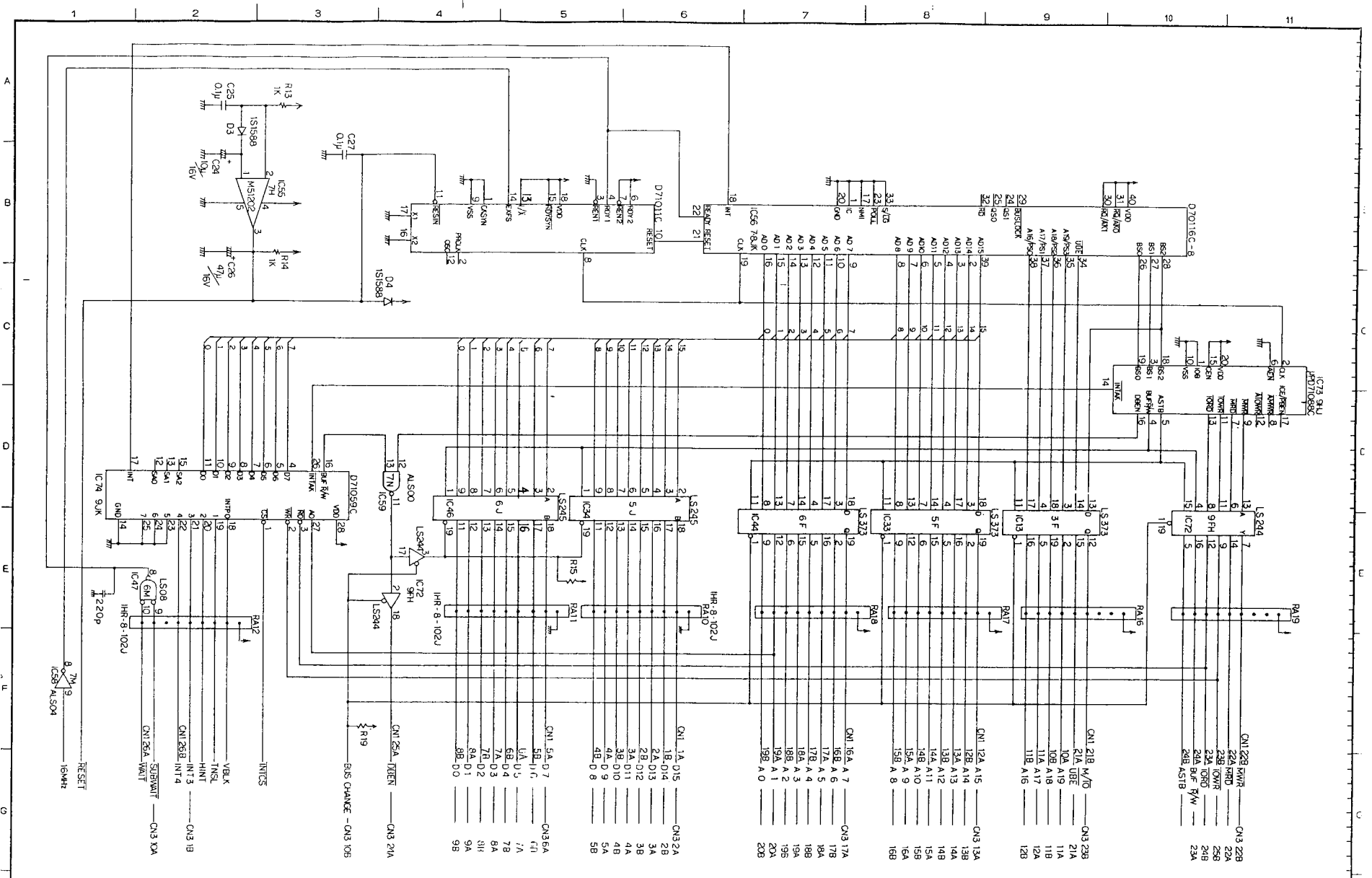

REV	DESCRIPTION	DATE	BY	CHECKED	DESIGNED	APPROVED
1	ISSUANCE					
2						
3						
4						
5						
6						
7						
8						
9						
10						
11						
12						

NANO CORPORATION

TITLE: **M72-A-C**

SCALE: **1/10**

DRAWN: **11-1-11**

CHECKED: **11-1-11**

DESIGNED: **11-1-11**

APPROVED: **11-1-11**

DATE: **11-1-11**

ITEM: **1**

DESCRIPTION: **1**

MATERIAL: **1**

REVISION: **1**

3RD ANGLE PROJECTION

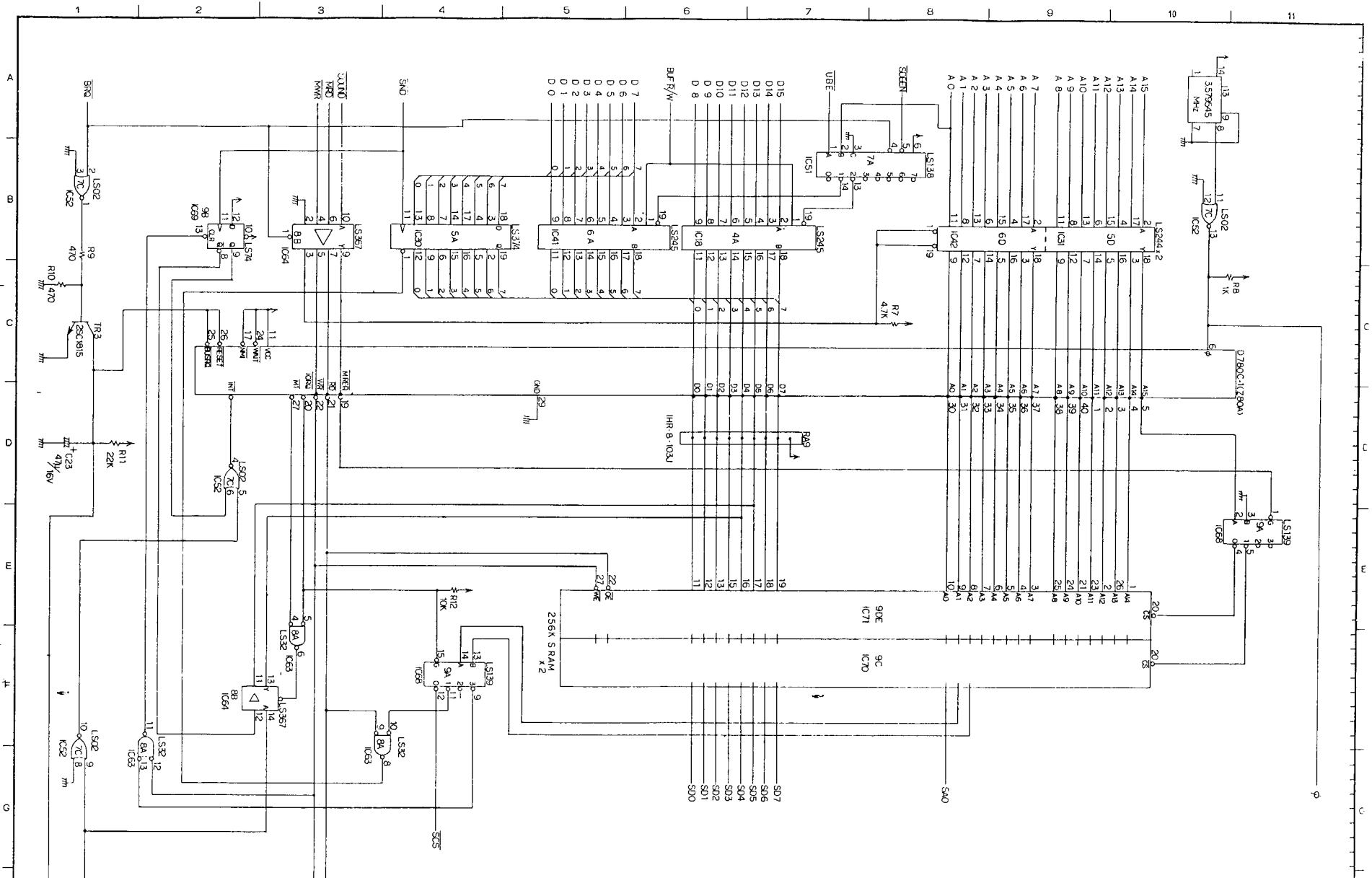

REV	DESCRIPTION	MATERIAL	MATERIAL CODE	REMARKS
1				
2				
3				
4				
5				
6				
7				
8				
9				
10				
11				

DATE	DRAWN	CHECKED	DESIGN APPROVED
11/13/01	11/13/01	11/13/01	11/13/01
SCALE	NTD		
1:1			

NANO NANO CORPORATION		TITLE	3/10
		M72-A-C	
		DRAW NO	
3RD ANGLE PROJECTION		CM	SHEET

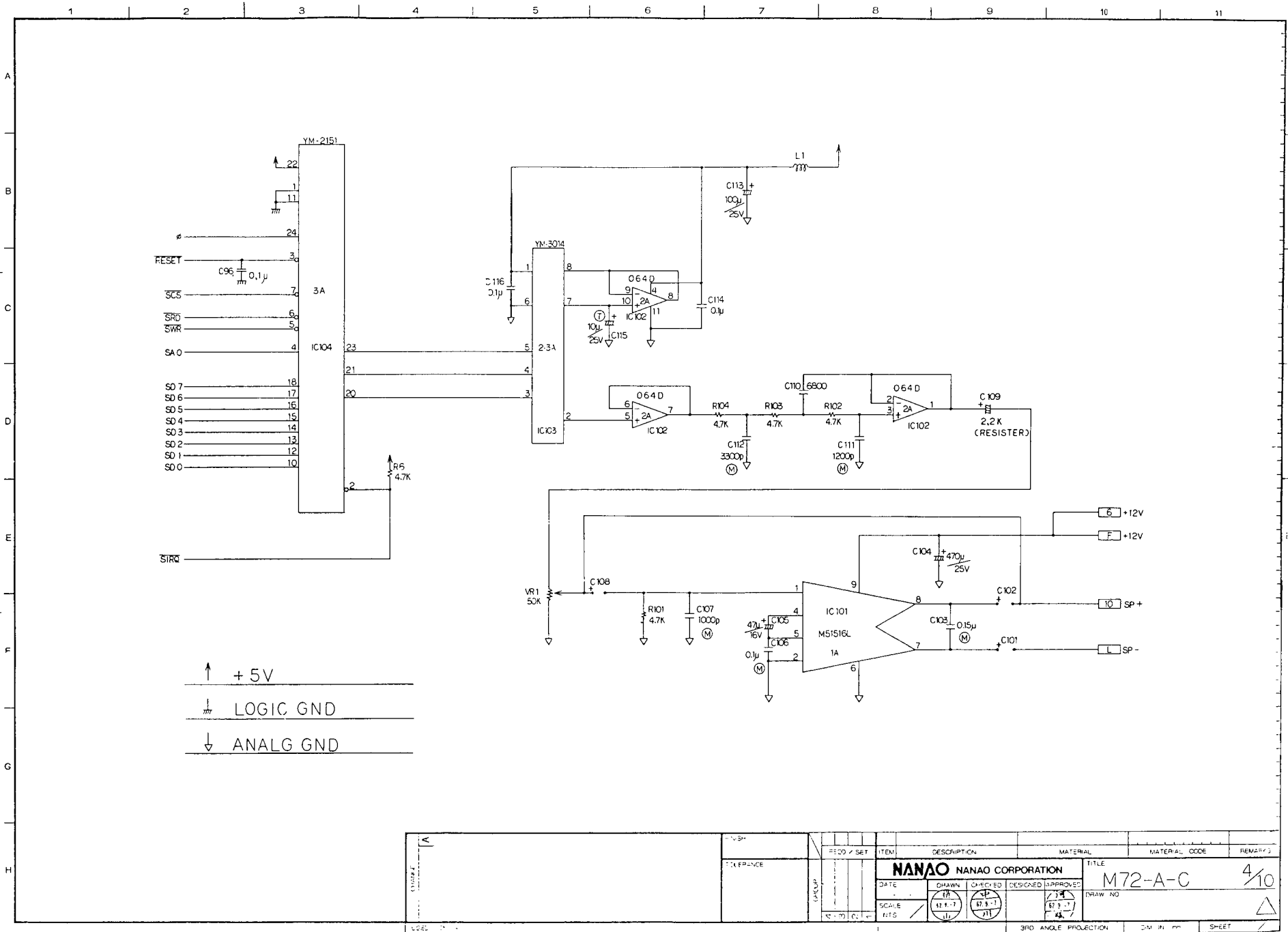

RECO	SET	ITEM	DESCRIPTION	MATERIAL	MATERIAL CODE	REMARKS
			NANO CORPORATION		TITLE: M72-A-C	
DATE	DRAWN	CHECKED	DESIGNED	APPROVED	DRAW NO.	
SCALE	1:1	1:1	1:1	1:1	4/10	
3RD ANGLE PROJECTION						SHEET

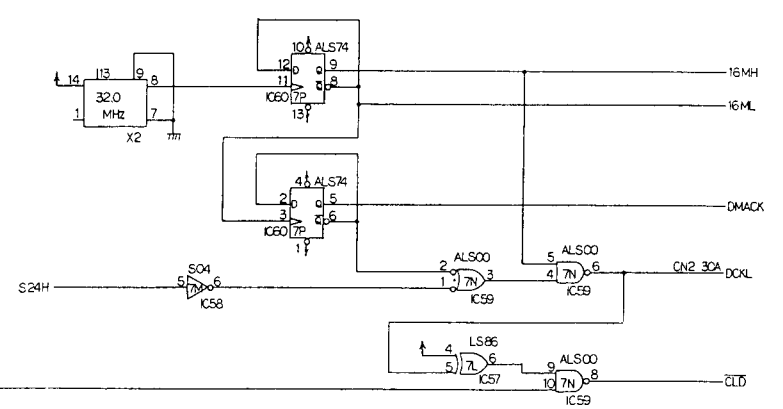
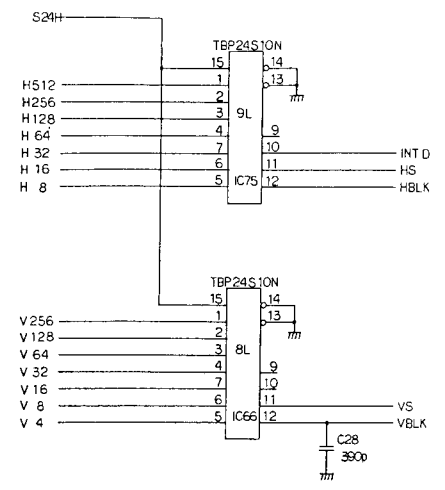
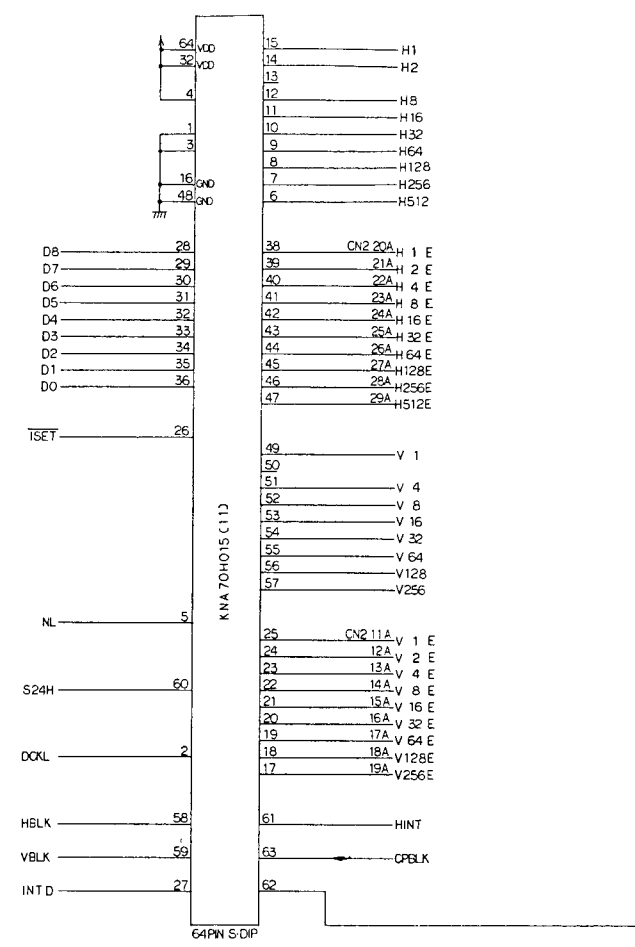

REV	DESCRIPTION	DATE	BY	CHKD	APP'D	TITLE	SHEET
1						M72-A-C	5/10
NANAO CORPORATION DATE: 18/11/11 LOCALS: 11/11/11 NTS: 11/11/11						TITLE: M72-A-C DRAW: 11/11/11	
3RD ANGLE PROJECTION						SHEET	

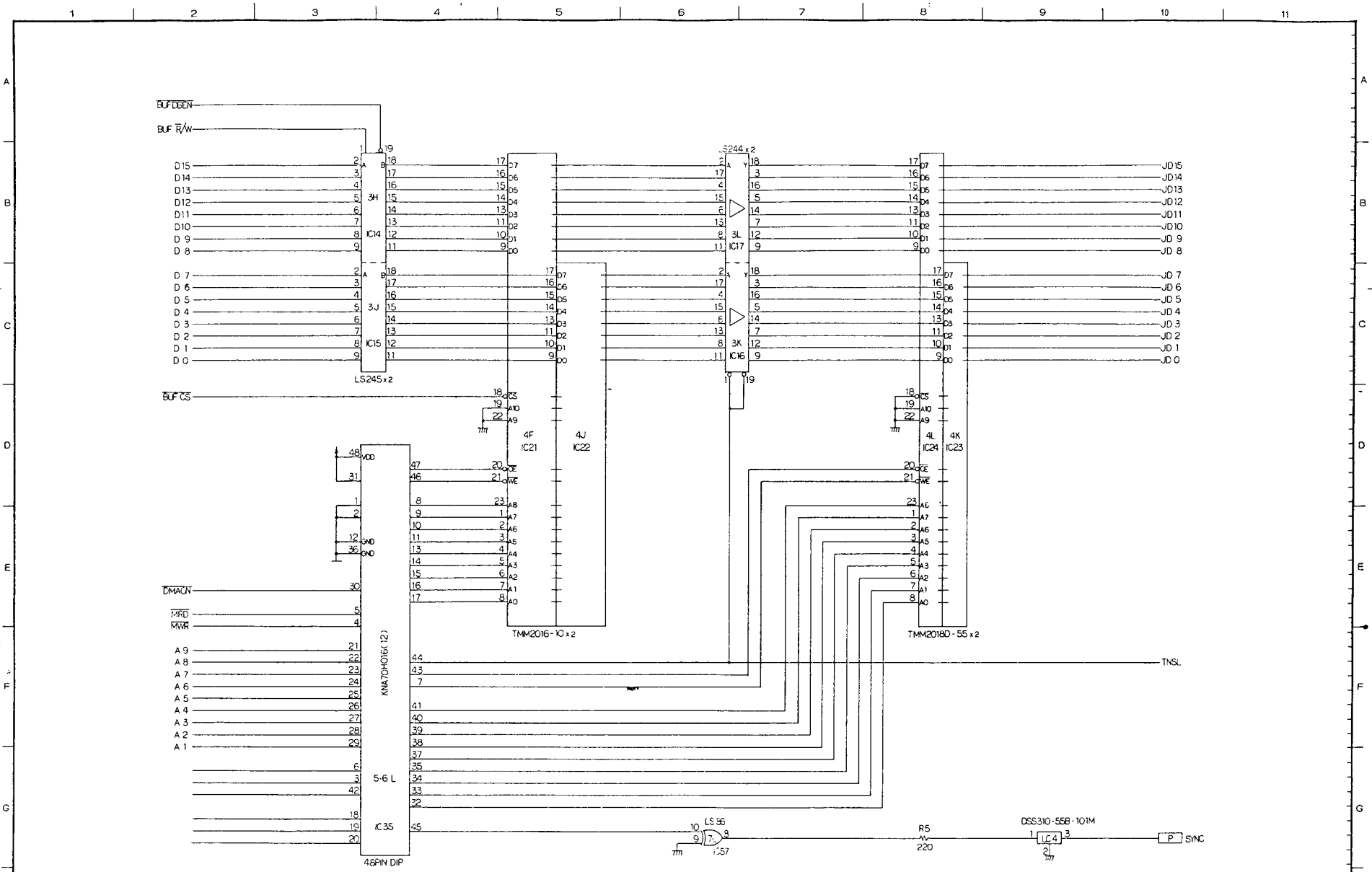

REV	SET	ITEM	DESCRIPTION	MATERIAL	MATERIAL CODE	REMARKS
1						
2						
3						
4						
5						
6						
7						
8						
9						
10						
11						

DRAWN		CHECKED		DESIGNED		APPROVED	
DATE	SCALE	NTS	DATE	SCALE	NTS	DATE	SCALE

NANO NANO CORPORATION		TITLE	
M72-A-C		6/10	
DRAW NO		SHEET	

3RD ANGLE PROJECTION DIM IN mm SHEET

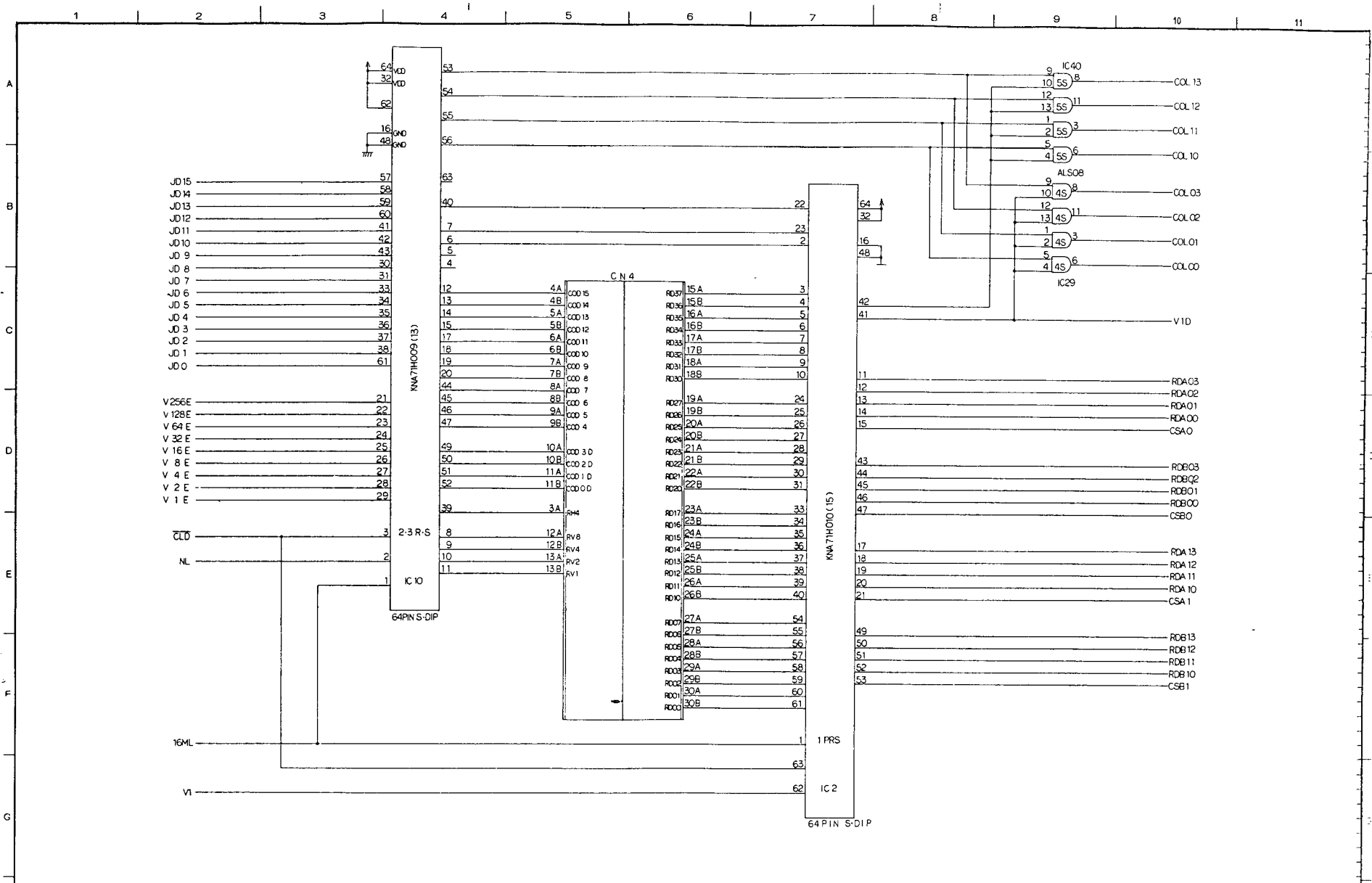

DATE	DRAWN	CHECKED	DESIGNED	APPROVED	TITLE	SHEET NO.	SHEET
NANO NANO CORPORATION				M72-A-C		7/10	
240 ANGLE PROJECTION				SHEET NO.		SHEET	

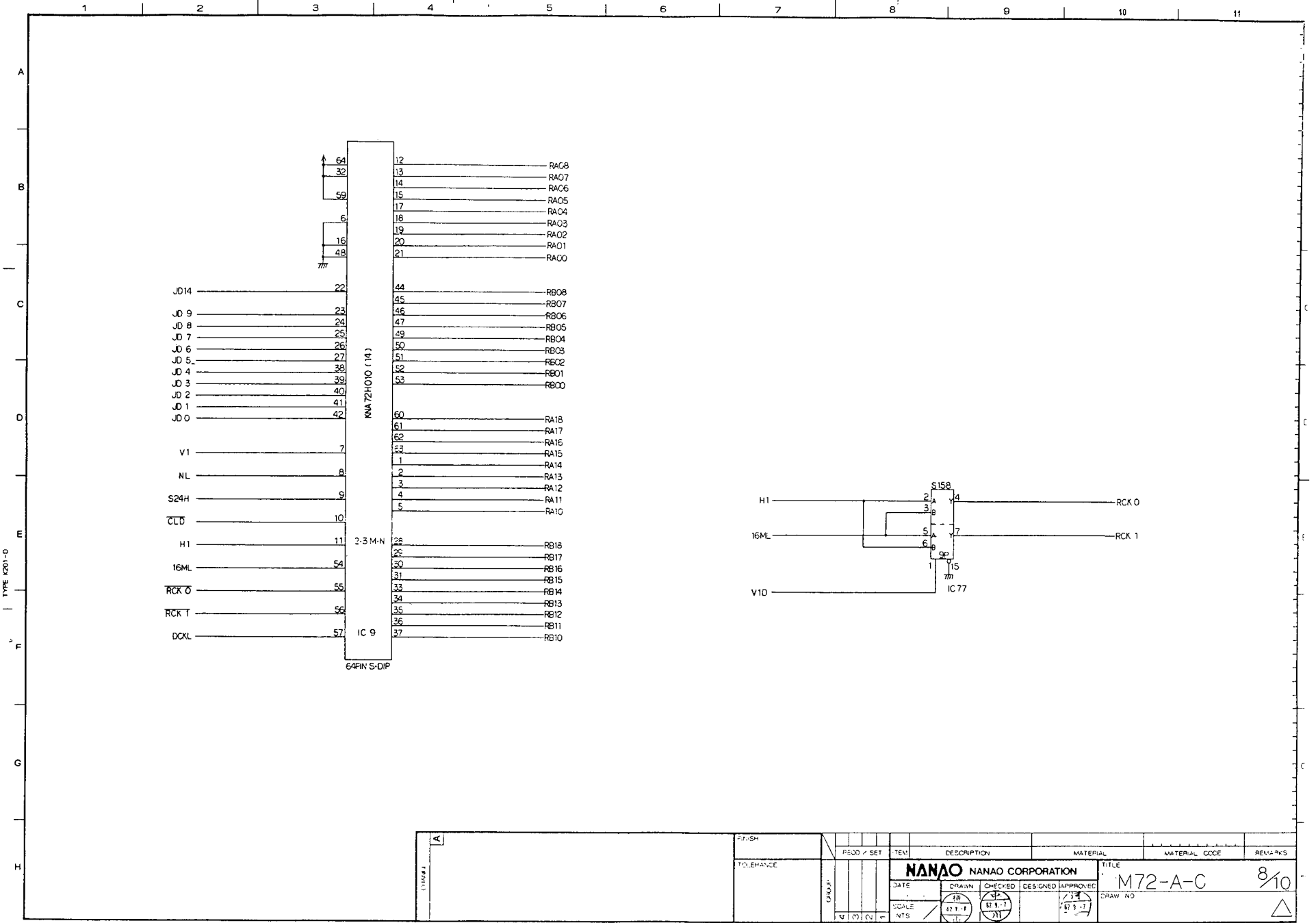

A	FINISH	RESO / SET	TECH	DESCRIPTION	MATERIAL	MATERIAL CODE	REMARKS
	TOLERANCE						
A	<p align="center">NANAO NANAO CORPORATION</p> <p>DATE: _____ DRAWN: _____ CHECKED: _____ DESIGNED: _____ APPROVED: _____</p> <p>SCALE: _____ MTS</p> <p align="right">TITLE: M72-A-C 8/10</p> <p align="right">DRAW NO: _____</p>						
	<p align="right">3RD ANGLE PROJECTION DIM IN mm SHEET</p>						
	<p>USED ON: _____</p>						

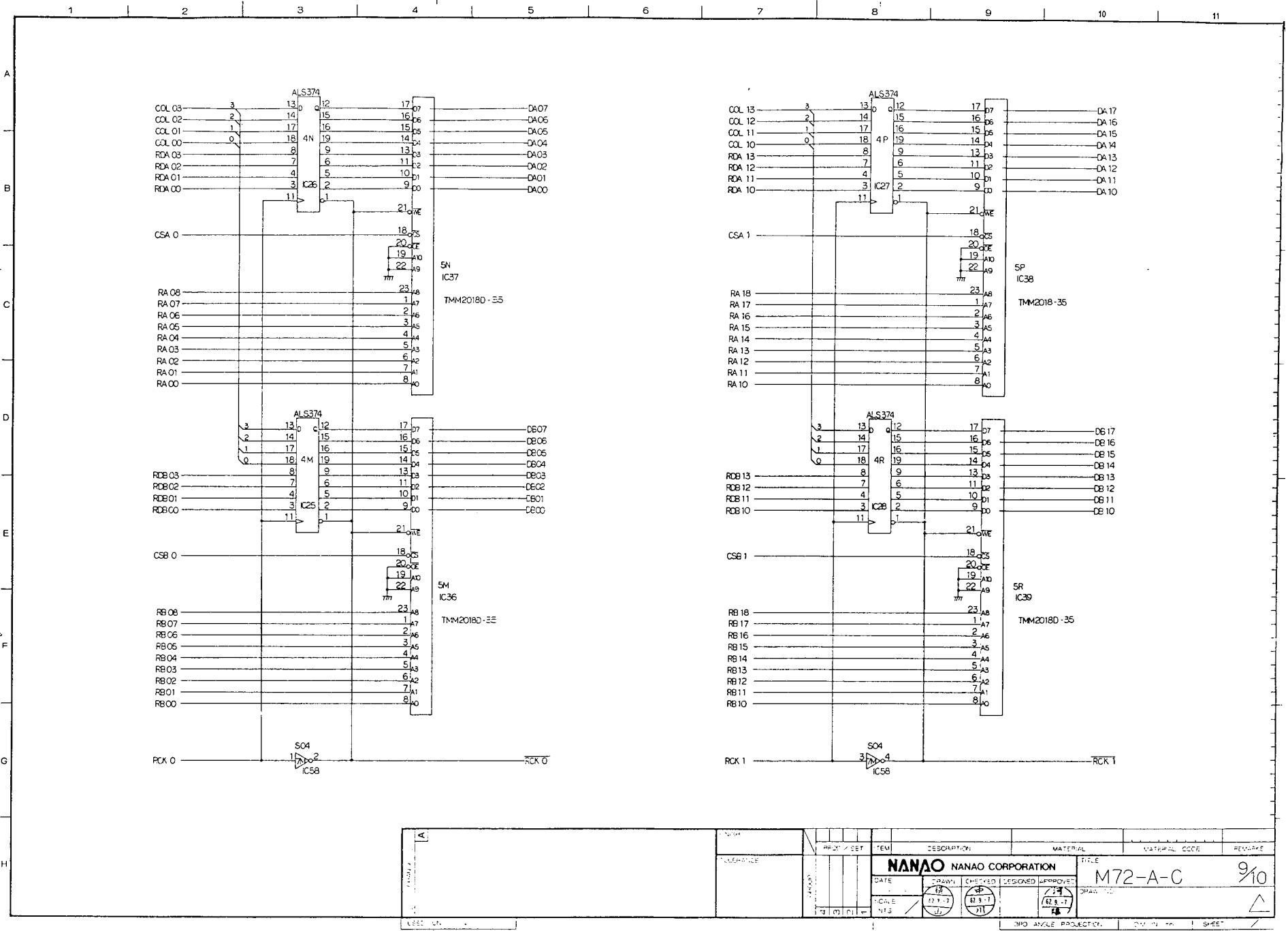

REV	DATE	DESCRIPTION	MATERIAL	MATERIAL CODE	REMARK
1	12.1.13				
NANAO CORPORATION TITLE: M72-A-C 9/10 DRAWN: [Signature] CHECKED: [Signature] DESIGNED: [Signature] APPROVED: [Signature]					
3RD ANGLE PROJECTION. QUANTITY SHEET					

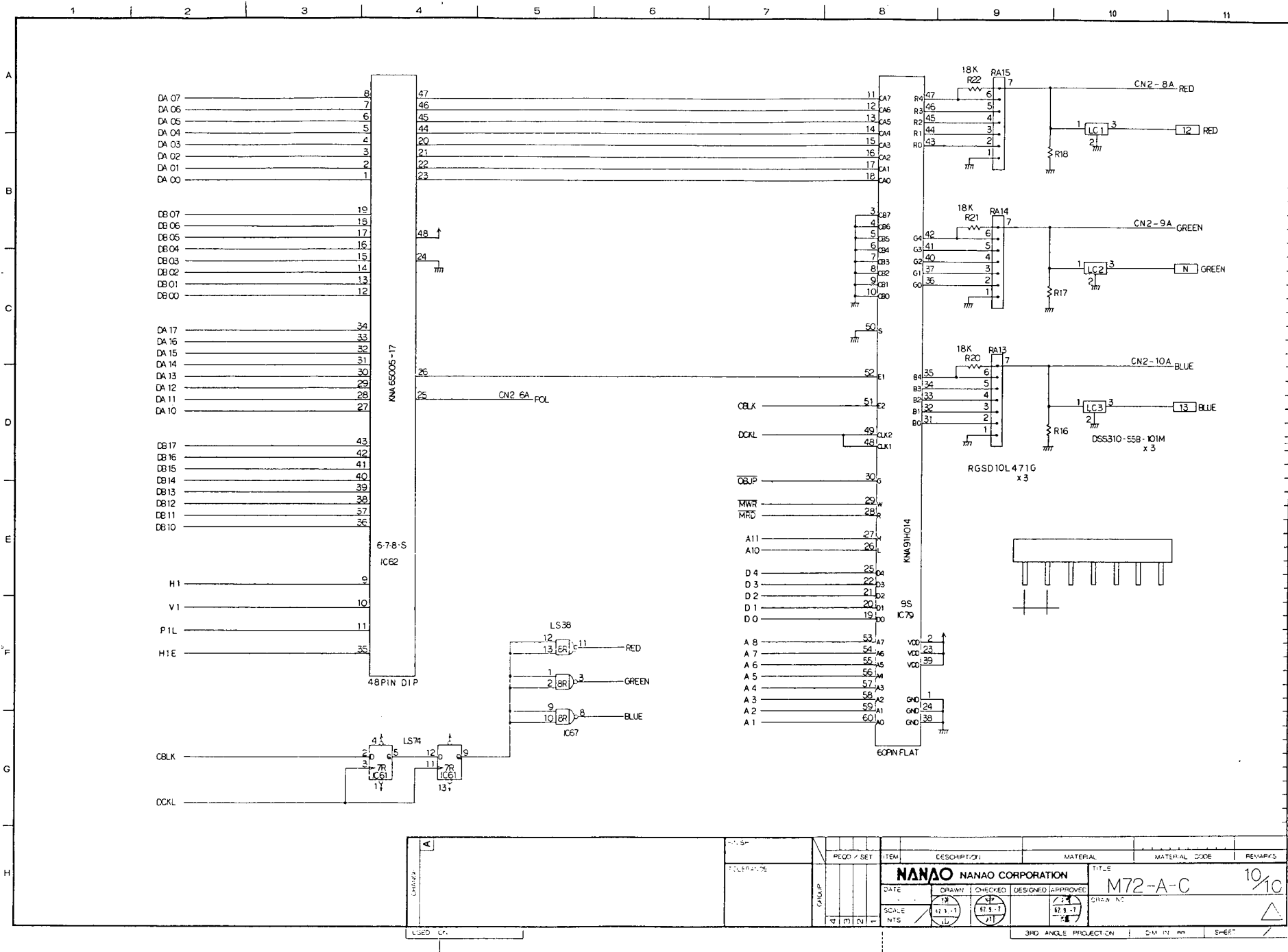

REV	DATE	DESCRIPTION	MATERIAL	MATERIAL CODE	REMARKS
1	12-11-71				
DRAWN		CHECKED		DESIGNED / APPROVED	
SCALE		NTS		DRAWN NO.	

NANAO CORPORATION

TITLE: **M72-A-C** 10/10

3RD ANGLE PROJECTION DIM IN mm SHEET