

1ST PRINTING JUNE '04

www.sauservice.com

SEGA®

SEGA PRESENTS

OutRun²

Standard Version

Owner's Manual



SEGA AMUSEMENTS USA, INC.

MANUAL NO. 999-2102

GAME CODE: ORT

VISIT OUR WEBSITE!

The screenshot shows a Mac OS X browser window displaying the SegaService.com website. The browser's address bar shows the URL <http://www.seuservice.com/>. The website's navigation menu on the left includes links for "What's new", "Manuals", "Bulletins", "Assemblies", "Graphics", "Specials", "Search", "Bulletin Sign-up", "Staff", "Darl's Office", "Return Policy", "Warranty Policy", "Corporate Info", "Home Page", "Plug-Ins", and "No Frames". The main content area features a large "SEGA SERVICE" logo, a graphic of a burning LED, and the text "LEDs 'Burning' you up ??". A list of navigation links is provided: "Bulletins", "Darl's Office", "Game Manuals", "Search", and "What's New". A message states: "If you have any questions or comments about this site please E-Mail to Darl.Davidson@seu.sega.com". Below this is a "POWERED BY Mac OS X" logo. A list of links is provided: "[what's new]", "[manuals]", "[bulletins]", "[assemblies]", "[specials]", "[Search]", "[staff]", "[Darl's office]", "[Return/Parts Policy]", "[warranty]", "[corporate info]", "[plugins]", and "[Non-framed page]". A note says: "You will need the following items to view this page in its entirety." Below this are logos for "Get Acrobat Reader" and "Microsoft Internet Explorer" for both Windows and Macintosh. The footer of the browser window shows "Internet zone".

BEFORE USING THE PRODUCT, BE SURE TO READ THE FOLLOWING:

To maintain the safety:

To ensure the safe usage of the product, be sure to read the following before using the product. The following instructions are intended for the users, operators and the personnel in charge of the operation of the product. After carefully reading and sufficiently understanding the warning displays and cautions, handle the product appropriately. Be sure to keep this manual nearby the product or elsewhere convenient for referring to it when necessary.

Herein, explanations which require special attention are enclosed with dual lines. Depending on the potentially hazardous degrees, the terms of WARNING, CAUTION, etc. are used. Be sure to understand the contents of the displays before reading the text.



Indicates that mishandling the product by disregarding this warning will cause a potentially hazardous situation which can result in death or serious injury.



Indicates that mishandling the product by disregarding this caution will cause a slight hazardous situation which can result in personal injury and or material damage.

For the safe usage of the product, the following pictographs are used:



Indicates “HANDLE WITH CARE.” In order to protect the human body and equipment, this display is attached to places where the Owner’s Manual and or Service Manual should be referred to.

- **Perform work in accordance with the instructions herein stated.**
Instructions for work are explained by paying attention to the aspect of accident prevention. Failing to perform work as per the instructions can cause accidents. In the case where only those who have technical expertise should perform the work to avoid hazardous situation, the instructions herein state that the serviceman should perform such work.
- **Be sure to turn off power before working on the machine.**
To prevent electric shock, be sure to turn off power before starting the work in which the worker touches the interior of the product. If the work is to be performed in the power-on status, the Instruction Manual herein always states to that effect.
- **Be sure to ground the Earth Terminal** (this, however, is not required in the case where a power cord with earth is used).
This product is equipped with the Earth Terminal. When installing the product, Connect the Earth Terminal to the “accurately grounded indoor earth terminal” by using an earth wire. Unless the product is grounded appropriately, the user can be subject to electric shock. After performing repair, etc. for the Control equipment, ensure that the Earth Wire is firmly connected to the Control equipment.
- **Ensure that the Power Supply used is equipped with an Earth Leakage Breaker.**
This product does not incorporate the Earth Leakage Breaker. Using a power supply which is not equipped with the Earth Leakage Breaker can cause a fire when earth leakage occurs.
- **Be sure to use fuses which meet the specified rating.** (only for the machines which use fuses).
Using fuses exceeding the specified rating can cause a fire and electric shock.

- **Specification changes (removal of equipment, conversion and addition) not designated by SEGA are not allowed.**
The parts of the product include warning labels for safety, covers for personal protection, etc. It is very hazardous to operate the product by removing parts and or modifying the circuits. Should doors, lids and protective parts be damaged or lost, refrain from operating the product, and contact where the product was purchased from or the office herein stated. SEGA shall not be held responsible for any accidents, compensation for damage to a third party, resulting from the specifications not designated by SEGA.
 - **Ensure that the product meets the requirements of appropriate Electrical Specifications.**
Before installing the product, check for Electrical Specifications. SEGA products have a nameplate on which Electrical Specifications are described. Ensure that the product is compatible with the power supply voltage and frequency requirements of the location. Using any Electrical Specifications different from the designated Specifications can cause a fire and electric shock.
 - **Install and operate the product in places where appropriate lighting is available, allowing warning labels to be clearly read.**
To ensure safety for the customers, labels and printed instructions describing potentially hazardous situation are applied to places where accidents can be caused. Ensure that where the product is operated has sufficient lighting allowing the warnings to be read. If any label is peeled off, apply it again immediately. Please place an order with where the product was purchased from or the office herein stated.
 - **When handling the Monitor, be very careful. (Applies only to the product w/monitor.)**
Some of the monitor (TV) parts are subject to high tension voltage. Even after running off power, some portions are still subject to high tension voltage sometimes. Monitor repair and replacement should be performed only by those technical personnel who have knowledge of electricity and technical expertise.
 - **Be sure to adjust the monitor (projector) properly. (Applies only to the product w/monitor.)**
Do not operate the product leaving on-screen flickering or blurring as it is. Using the product with the monitor not properly adjusted may cause dizziness or a headache to an operator, a player, or the customers.
 - **When transporting or reselling this product, be sure to attach this manual to the product.**
In the case where commercially available monitors and printers are used in this product, only the contents relating to this product are explained herein. Some commercially available equipment has functions and reactions not stated in this manual. Read this manual together with the specific Instruction Manual of such equipment.
- Descriptions herein contained may be subject to improvement changes without notice.
 - The contents described herein are fully prepared with due care. However, should any question arise or errors be found, please contact SEGA.

INSPECTIONS IMMEDIATELY AFTER TRANSPORTING THE PRODUCT TO THE LOCATION.

Normally, at the time of shipment, SEGA products are in a status allowing for usage immediately after transporting to the location. Nevertheless, an irregular situation may occur during transportation. Before turning on power, check the following points to ensure that the product has been transported in a satisfactory status.

- Are there any dented portions or defects (cuts, etc.) on the external surfaces of the cabinet?
- Are Casters and Adjusters, damaged?
- Do the power supply voltage and frequency requirements meet with those of the location?
- Are all wiring connectors correctly and securely connected? Unless connected in the correct direction, connector connections can not be made accurately. Do not insert connectors forcibly.
- Do power cords have cuts and dents?
- Do the fuses used meet specified rating? Is the Circuit Protector in an energized status?
- Are all accessories available?
- Can all Doors and Lids be opened with the Accessory keys? Can Doors and Lids be firmly closed?

TABLE OF CONTENTS

BEFORE USING THE PRODUCT, BE SURE TO READ THE FOLLOWING:

TABLE OF CONTENTS

INTRODUCTION OF THE OWNER'S MANUAL

1. HANDLING PRECAUTIONS	1 - 2
2. PRECAUTIONS CONCERNING INSTALLATION LOCATION	3 - 4
3. OPERATION	5 - 8
4. NAME OF PARTS	9
5. ACCESSORIES	10 - 12
6. ASSEMBLING AND INSTALLATION	13 - 22
7. PRECAUTIONS WHEN MOVING THE MACHINE	23
8. GAME DESCRIPTION	24 - 33
9. GAME TEST MODE	34 - 40
10. EXPLANATION OF TEST AND DATA DISPLAY	41 - 42
11. HANDLE MECHANISM	43 - 45
12. SHIFT LEVER	46 - 47
13. ACCEL & BRAKES(S)	48 - 49
14. COIN SELECTOR	50 - 52
15. MONITOR	53 - 54
16. PERIODIC INSPECTION TABLE	55 - 56
17. GAME BOARD	57 - 63
18. NETWORK PLAY	64 - 66
19. DESIGN RELATED PARTS	67
20. PARTS LIST	68 - 75
21. WIRE COLOR CODE TABLE	76
22. WIRING DIAGRAMS	XXX

SPECIFICATIONS

Installation Space	: 75.5 inches wide X 38.75 inches deep
Height	: 70 inches
Width	: 30.25 inches
Length	: 67.5 inches
Weight	: ~680 lbs
Power, maximum current	: 540 W 4.5 A (AC 120V 60 Hz AREA)

MONITOR	: 29 inch supplied by Sanwa
	Monitor: 998-0612
	Chassis: 998-0161

INTRODUCTION OF THE OWNERS MANUAL

This Owner's Manual is intended to provide detailed descriptions together with all the necessary information covering the general operation of electronic assemblies, electromechanicals, servicing control, spare parts, etc. as regards the product,

OUTRUN 2 STANDARD TYPE.

This manual is intended for the owners, personnel and managers in charge of operation of the product. Operate the product after carefully reading and sufficiently understanding the instructions. If the product fails to function satisfactorily, non-technical personnel should under no circumstances touch the internal system. Please contact where the product was purchased from.

Use of this product is unlikely to cause physical injuries or damages to property. However, where special attention is required this is indicated by a thick line, the word "IMPORTANT" and its sign in this manual.



Indicates that mishandling the product by disregarding this display can cause the product's intrinsic performance not to be obtained, resulting in malfunctioning.

IMPORTANT!

SEGA AMUSEMENTS USA, INC. / CUSTOMER SERVICE
45133 Industrial Drive, Fremont, California 94538, U.S.A.
Phone : (415) 701-6580
Fax : (415) 701-6594

DEFINITION OF LOCATION MAINTENANCE MAN AND SERVICEMAN



Non-technical personnel who do not have technical knowledge and expertise should refrain from performing such work that this manual requires the location's maintenance man or a serviceman to carry out, or work which is not explained in this manual. Failing to comply with this instruction can cause a severe accident such as electric shock.

Ensure that parts replacement, servicing & inspections, and troubleshooting are performed by the location's maintenance man or the serviceman. It is instructed herein that particularly hazardous work should be performed by the serviceman who has technical expertise and knowledge.

The location's maintenance man and serviceman are herein defined as follows:

"Location's Maintenance Man" :

Those who have experience in the maintenance of amusement equipment and vending machines, etc., and also participate in the servicing and control of the equipment through such routine work as equipment assembly and installation, servicing and inspections, replacement of units and consumables, etc. within the Amusement Facilities and or locations under the management of the Owner and Owner's Operators of the product.

Activities of Location's Maintenance Man :

Assembly & installation, servicing & inspections, and replacement of units & consumables as regards amusement equipment, vending machines, etc.

Serviceman :

Those who participate in the designing, manufacturing, inspections and maintenance service of the equipment at an amusement equipment manufacturer.

Those who have technical expertise equivalent to that of technical high school graduates as regards electricity, electronics and or mechanical engineering, and daily take part in the servicing & control and repair of amusement equipment.

Serviceman's Activities :

Assembly & installation and repair & adjustments of electrical, electronic and mechanical parts of amusement equipment and vending machines.

LISTED



AMUSEMENT MACHINE

Notes:

1. HANDLING PRECAUTIONS

When installing or inspecting the machine, be very careful of the following points and pay attention to ensure that the player can enjoy the game safely.

Non-compliance with the following points or inappropriate handling running counter to the cautionary matters herein stated can cause personal injury or damage to the machine.



- Before performing work, be sure to turn power off. Performing the work without turning power off can cause an electric shock or short circuit. In the case work should be performed in the status of power on, this manual always states to that effect.
- To avoid electric shock or short circuit, do not plug in or unplug quickly.
- To avoid electric shock, do not plug in or unplug with a wet hand.
- Do not expose Power Cords and Earth Wires on the surface, (floor, passage, etc.). If exposed, the Power Cords and Earth Wires are susceptible to damage. Damaged cords and wires can cause electric shock or short circuit.
- To avoid causing a fire or electric shock, do not put things on or damage Power Cords.
- When or after installing the product, do not unnecessarily pull the power cord. If damaged, the power cord can cause a fire or electric shock.
- In case the power cord is damaged, ask for replacement through where the product was purchased from or the office herein stated. Using the cord as is damaged can cause fire, electric shock or leakage.
- Be sure to perform grounding appropriately. Inappropriate grounding can cause an electric shock.
- Be sure to use fuses meeting specified rating. Using fuses exceeding the specified rating can cause a fire or electric shock.
- Completely make connector connections for IC BD and others. Insufficient insertion can cause an electric shock.
- Specification changes, removal of equipment, conversion and/or addition, not designated by SEGA are not permitted.
 - Failure to observe this may cause a fire or an electric shock. Non-compliance with this instruction can have a bad influence upon physical conditions of the players or the lookers-on, or result in injury during play.
 - SEGA shall not be held responsible for damage, compensation for damage to a third party, caused by specification changes not designated by SEGA.
- Be sure to perform periodic maintenance inspections herein stated.



IMPORTANT!

- For the IC board circuit inspections, only the logic tester is allowed. The use of a multiple-purpose tester is not permitted, so be careful in this regard.
- The Projector is employed for this machine. The Projector's screen is susceptible to damage, therefore, be very careful when cleaning the screen. For details, refer to PROJECTOR.
- Static electricity from your body may damage some electronics devices on the IC board. Before handling the IC board, touch a grounded metallic surface so that the static electricity can be discharged.
- Some parts are the ones designed and manufactured not specifically for this game machine. The manufacturers may discontinue, or change the specifications of, such general-purpose parts. If this is the case, Sega cannot repair or replace a failed game machine whether or not a warranty period has expired.

◆ PRODUCTION DATE ◆

This SEGA product was produced in the year of:

2004

This signifies that this work was disclosed in 2004.

2. PRECAUTIONS CONCERNING INSTALLATION LOCATION



This product is an indoor game machine. Do not install it outside. Even indoors, avoid installing in places mentioned below so as not to cause a fire, electric shock, injury and or malfunctioning.

- Places subject to rain or water leakage, or places subject to high humidity in the proximity of an indoor swimming pool and or shower, etc.
- Places subject to direct sunlight, or places subject to high temperatures in the proximity of heating units, etc.
- Places filled with inflammable gas or vicinity of highly inflammable/volatile chemicals or hazardous matter.
- Dusty places.
- Sloped surfaces.
- Places subject to any type of violent impact.
- Vicinity of anti-disaster facilities such as fire exits and fire extinguishers.
- The operating (ambient) temperature range is from 5°C to 30°C.

LIMITATIONS OF USAGE REQUIREMENTS



- Be sure to check the Electrical Specifications.
Ensure that this product is compatible with the location's power supply, voltage and frequency requirements.
A plate describing Electrical Specifications is attached to the product.
Non-compliance with the Electrical Specifications can cause a fire and electric shock.
- This product requires the Breaker and Earth Mechanisms as part of the location facilities. Using them in a manner not independent can cause a fire and electric shock.
- Ensure that the indoor wiring for the power supply is rated at 10 A or higher (AC single phase 100 ~ 120 V area). Non-compliance with the Electrical Specifications can cause a fire and electric shock.
- Be sure to independently use the power supply equipped with the Earth Leakage Breaker. Using a power supply without the Earth Leakage Breaker can cause an outbreak of fire when earth leakage occurs.
- Putting many loads on one electrical outlet can cause generation of heat and a fire resulting from overload.
- When using an extension cord, ensure that the cord is rated at 10 A or higher (AC 100 ~ 120 V area). Using a cord rated lower than the specified rating can cause a fire and electric shock.

Operation Area



- For the operation of this machine, secure a minimum area of 38.75 in. (W) × 75.5 in. (D). In order to prevent injury resulting from the falling down accident during game play, be sure to secure the minimum area for operation.
- Be sure to provide sufficient space so as to allow this product's ventilation fan to function efficiently. To avoid machine malfunctioning and a fire, do not place any obstacles near the ventilation opening.
- SEGA shall not be held responsible for damage, compensation for damage to a third party, resulting from the failure to observe this instruction.



For transporting the machine into the location's building, the minimum necessary dimensions of the opening (of doors, etc.) are 32.75 in. (W) and 71 in. (H).

Electric current consumption

MAX. 4.5 A (AC 120 V 60 Hz)

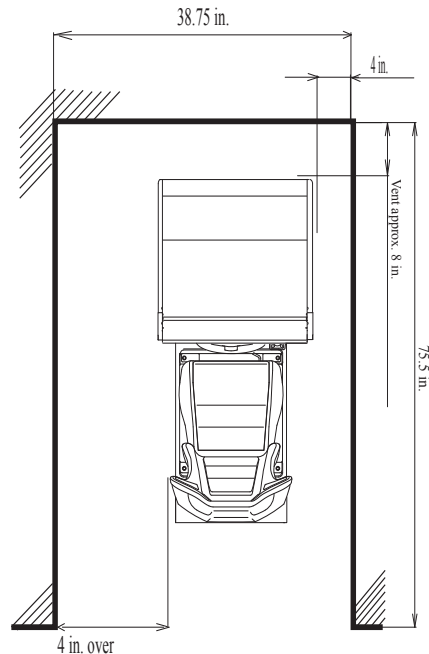

FIG. 2

3. OPERATION

PRECAUTIONS TO BE HEEDED BEFORE STARTING THE OPERATION

To avoid injury and trouble, be sure to constantly give careful attention to the behavior and manner of the visitors and players.



In order to avoid accidents, check the following before starting the operation:

- To ensure maximum safety for the players and the customers, ensure that where the product is operated has sufficient lighting to allow any warnings to be read. Operation under insufficient lighting can cause bodily contact with each other, hitting accident, and or trouble between customers.
- Be sure to perform appropriate adjustment of the monitor (projector). For operation of this machine, do not leave monitor's flickering or deviation as is. Failure to observe this can have a bad influence upon the players' or the customers' physical conditions.
- It is suggested to ensure a space allowing the players who feel sick while playing the game to take a rest.
- Check if all of the adjusters are in contact with the surface. If they are not, the Cabinet can move and cause an accident.

Ensure that all of the SUPPORT BRACKET are in contact with the floor.

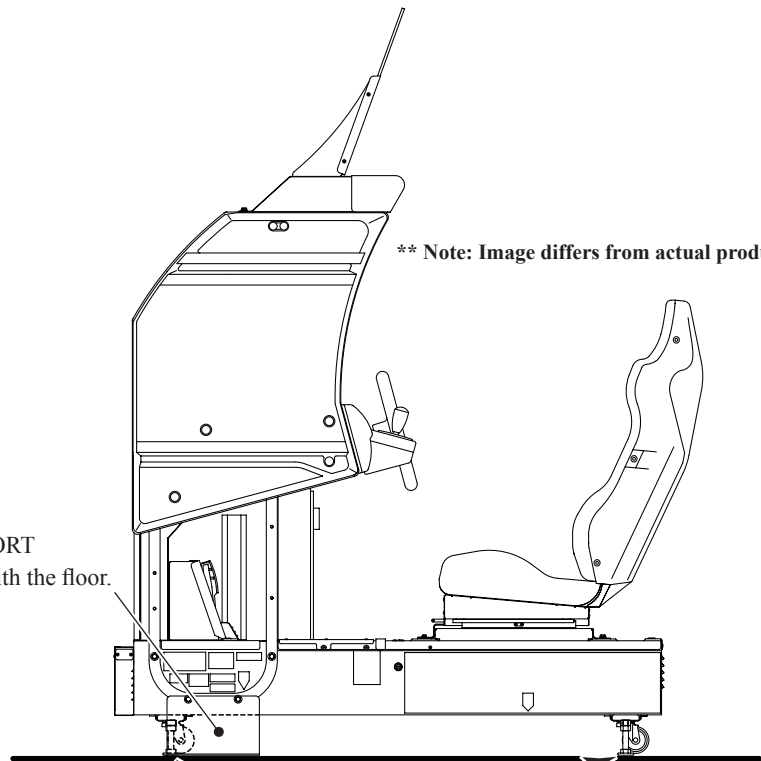

** Note: Image differs from actual product.

Ensure that all of the Adjusters are in contact with the floor.



- Do not put any heavy item on this product. Placing any heavy item on the product can cause a falling down accident or parts damage.
- Do not climb on the product. Climbing on the product can cause falling down accidents. To check the top portion of the product, use a step.
- To avoid electric shock, check to see if door & cover parts are damaged or omitted.
- To avoid electric shock, short circuit and or parts damage, do not put the following items on or in the periphery of the product.
Flower vases, flowerpots, cups, water tanks, cosmetics, and receptacles/
containers/vessels containing chemicals and water.



To avoid injury, be sure to provide sufficient space by considering the potentially crowded situation at the installation location. Insufficient installation space can cause making bodily contact with each other, hitting accidents, and or trouble between customers.

PRECAUTIONS TO BE HEEDED DURING OPERATION (PAYING ATTENTION TO CUSTOMERS)

To avoid injury and trouble, be sure to constantly give careful attention to the behavior and manner of the visitors and players.



- To avoid injury and accidents, those who fall under the following categories are not allowed to play the game.
 - Those who need assistance such as the use of an apparatus when walking.
 - Those who have high blood pressure or a heart problem.
 - Those who have experienced muscle convulsion or loss of consciousness when playing video game, etc.
 - Those who have a trouble in the neck and or spinal cord.
 - Intoxicated persons.
 - Pregnant women or those who are in the likelihood of pregnancy.
 - Persons susceptible to motion sickness.
 - Persons whose act runs counter to the product's warning displays.
- A player who has never been adversely affected by light stimulus might experience dizziness or headache depending on his physical condition when playing the game. Especially, small children can be subject to those conditions. Caution guardians of small children to keep watch on their children during play.
- Instruct those who feel sick during play to have a medical examination.
- To avoid injury resulting from falling down and electric shock due to spilled drinks, instruct the player not to place heavy items or drinks on the product.
- To avoid electric shock and short circuit, do not allow customers to put hands and fingers or extraneous matter in the openings of the product or small openings in or around the doors.
- To avoid falling down and injury resulting from falling down, immediately stop the customer's leaning against or climbing on the product, etc.



- To avoid electric shock and short circuit, do not allow the customers to unplug the power plug without a justifiable reason.
- This product is intended for 1 Player only per seat. Playing the game by 2 or more Players riding on the seat together can cause falling down and collision accidents by striking head, hand, or elbow.
- Caution lookers-on so as not to touch the operating unit while in play. Failure to observe this may cause bodily contact with the player and trouble between the customers.

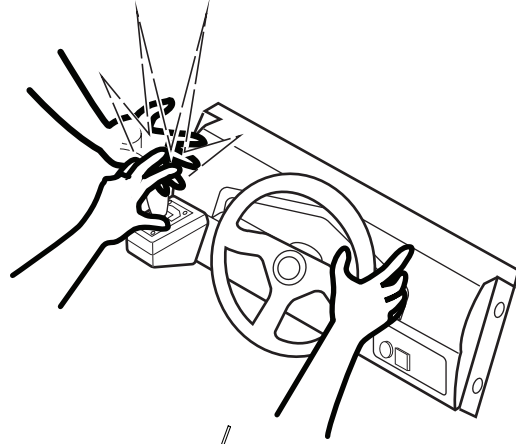

** Note: Image differs from actual product.

- Caution the player so as not to hold a child in her/his lap to play. Failure to observe this may cause the child to be caught between the Control Panel and the player and fall down.

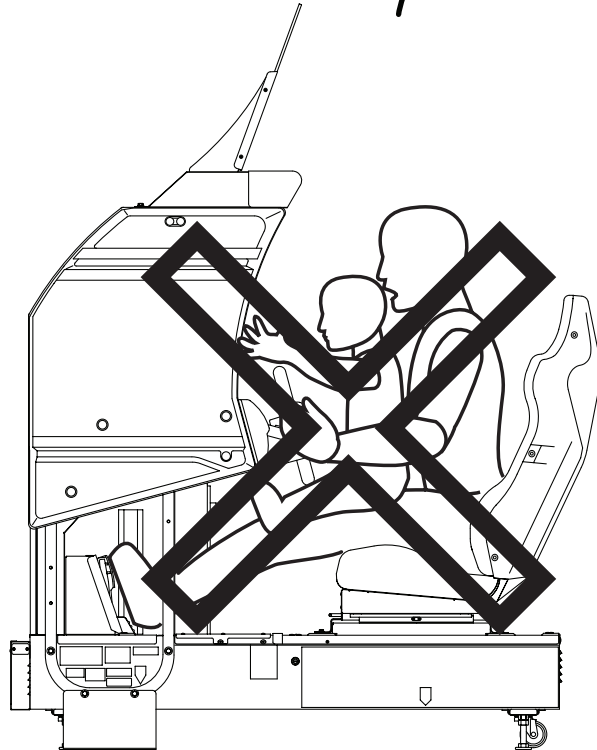

** Note: Image differs from actual product.



- Immediately stop such violent acts as hitting and kicking the product. Such violent acts can cause parts damage or falling down, resulting in injury due to fragments and falling down.
- Instruct the Player to adjust the seat before playing the game. Playing the game in a forcible posture can cause a contingent accident.

PRECAUTIONS TO BE HEDED BEFORE STARTING THE OPERATION (CARD SYSTEM)



IMPORTANT!

When an unjust act is performed, no written data is backed up mechanically. The following acts may be judged to be unjust acts. Since it also becomes a defect of operation and the cause of parts damage, caution the player not to perform the following acts.

- Use of cards bent or deformed
- Use of cards adhered seals or extraneous matter on
- Use of a card mixed two sheets
- Use of cards other than dedicated cards
- When a card is extracted quickly

If the card reader/writer has not been set as being unused, you will be unable to select any game mode with use of cards while the game will be in progress.

Thus, for the card reader/writer, deal with the player, paying attention to the following points:

Even if the player requests the system for use of cards when you have set the machine so that the card reader/writer is not used, the request is rejected.



WARNING!

WARNING: HAZARD TO EPILEPTICS.

- A very small portion of the population has a condition which may cause them to experience epileptic seizures or have momentary loss of consciousness when viewing certain kinds of flashing lights or patterns that are present in our daily environment. These persons may experience seizures while watching some kinds of television pictures or playing certain video games. People who have not had any previous seizures may nonetheless have an undetected epileptic condition.
- If you or anyone in your family has experienced symptoms linked to an epileptic condition (e.g., seizures or loss of awareness), immediately consult your physician before using any video games.
- We recommend that parents observe their children while they play video games. If you or your child experience the following symptoms: dizziness, altered vision, eye or muscle twitching, involuntary movements, loss of awareness, disorientation, or convulsions, **DISCONTINUE USE IMMEDIATELY** and consult your physician.

4. NAME OF PARTS



TABLE 4 Dimensions and Weights

	Width x Length x Height	Weight
When assembled	30 in x 67.5 in x 70 in	~680 LBS

5. ACCESSORIES

When transporting the machine, make sure that the following parts are supplied. Magnetic cards for the recording of play results, and cleaning kits for cleaning the head of the card reader/writer are sold separately. Subsequent purchases of these items can be made by contacting the office listed on this Owner's Manual or the dealer from whom the product was originally purchased. Be sure to provide the part number(s), name(s), and required number of items.

TABLE 5 a ACCESSORIES

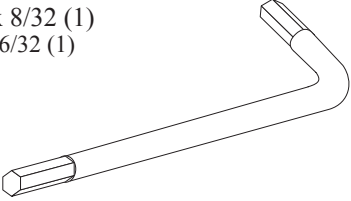
<p>DESCRIPTION</p> <p>Part No. (Qty.)</p> <p>Notes</p> <p>Figures</p> <p>Parts not labeled with part numbers are as yet unregistered or cannot be registered. Be sure to handle all parts with care, as some parts are not available for purchase separately.</p>	<p>OWNER'S MANUAL</p> <p>999-2102</p>	<p>KEY MASTER</p> <p>9301A (2)</p> <p>For opening/closing the doors</p>	<p>KEY</p> <p>(2)</p> <p>For the CASHBOX DOOR</p>
		<p>The Keys are inside the Coin Chute Door at the time of shipment from the factory.</p>	
		<p>TAMPERPROOF WRENCH</p> <p>3/16 TMP SCR (1)</p> <p>T-27 Torx 1/4-20 (1)</p> <p>T-15 Torx 8/32 (1)</p> <p>T-10 Torx 6/32 (1)</p> <p>Tool</p>	
			

The following Table 5b lists the parts that are separately marketed but are necessary when booting this product's software. When having unpacked the shipping crate, make sure that all the parts in this Table 5b are in the crate. If not so, contact where you have obtained the product.

TABLE 5 b (XKT-0833 : GD-ROM DRIVE KIT)

<p>GD-ROM DRIVE XKT-0833 Device that loads the software in a GD-ROM disc. see 5 of Section 6.</p>	<p>GD-ROM DRIVE CARTON BOX (1) Used for transporting the GD-ROM DRIVE. See FIG. 5 b.</p>
	
	<p>This carton box is a standard accessory of the GD-ROM drive.</p>

TABLE 5 c

<p>GD ROM KIT ORT</p>	<p>CUSHION SPONGE 601-11137 (1) GD-ROM Disc Protector</p>
<p>KEY CHIP (1)</p>	
<p>CHIHIRO GDROM ORT ENG (1)</p>	
<p>NOTE: When you order the GD-ROM disc only, specify the part number 610-0652-0004 (GD SOFT ORT ENG).</p>	

HOW TO USE THE CARTON BOX (GD-ROM DRIVE)

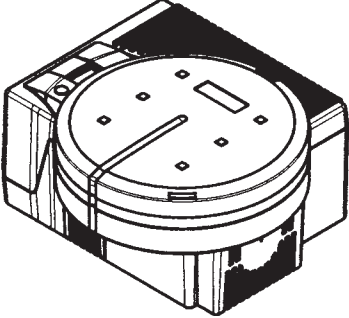
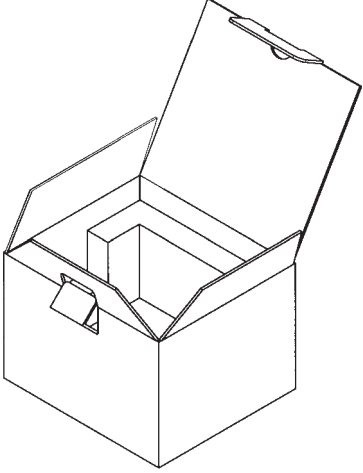
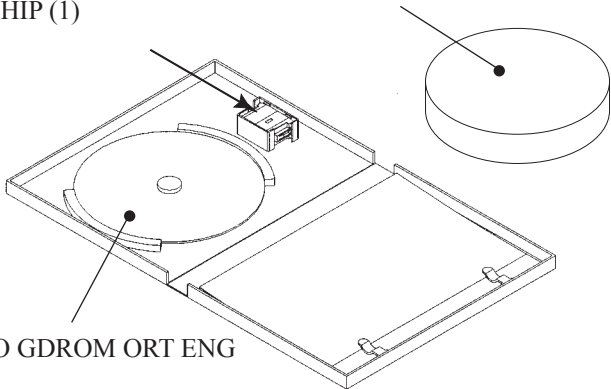

When you want to order for replacing or repairing service of the GD-ROM drive that is used by the product, pack it in a carton box as instructed below, and then deliver the carton box to a service agent. If you do not observe the instruction, your order may not be accepted or may be charged additionally. If you handle the GD-ROM drive differently from the following instructions, its components may be damaged.

- Contain the GD-ROM drive in a dedicated carton box. Do not disassemble it or remove any part from it unless otherwise instructed.
- Before containing the GD-ROM drive in a dedicated carton box, attach the GD-ROM drive lid (DISC LID) onto the drive and fix the lid with a screw.
- Before containing the GD-ROM drive in a dedicated carton box, remove the GD-ROM disk from the drive. Do not attempt to move the GD-ROM drive with a GD-ROM disk inside.
- Before containing the GD-ROM drive in a dedicated carton box, remove the GD-ROM drive bracket. Carefully keep the GD-ROM drive bracket and the 4 set screws, because they will be reused.
- When inserting the GD-ROM drive into a dedicated carton box, be careful about an inserting direction as illustrated below.
- The packing materials in a carton box are used as a cushion. Use them always when inserting the GD-ROM drive into a dedicated carton box. Do not bend them.

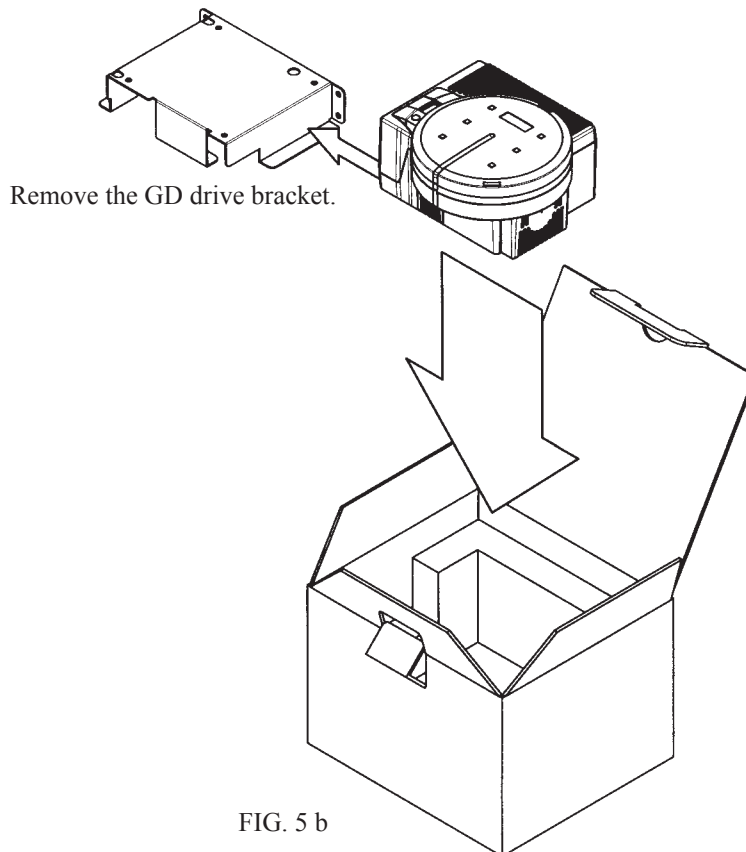

FIG. 5 b

6. ASSEMBLING AND INSTALLATION



- Perform assembly work by following the procedure herein stated. Failing to comply with the instructions can cause electric shock hazard.
- Perform assembling as per this manual. Since this is a complex machine, erroneous assembling can cause an electric shock, machine damage and or not functioning as per specified performance.
- When assembling, be sure to use plural persons. Depending on the assembly work, there are some cases in which working by one person alone can cause personal injury or parts damage.
- Ensure that connectors are accurately connected. Incomplete connections can cause electric shock hazard.
- Be careful not to damage the wires. Damaged wires may cause electric shock or short circuit or present a fire risk.
- This work should be performed by the Location's Maintenance Man or Serviceman. Performing work by non-technical personnel can cause a severe accident such as electric shock. Failing to comply with this instruction can cause a severe accident such as electric shock to the player during operation.
- Provide sufficient space so that assembling can be performed. Performing work in places with narrow space or low ceiling may cause an accident and assembly work to be difficult.
- To perform work safely and avoid serious accident such as the cabinet's falling down, do not perform work in places where step-like grade differences, a ditch, or slope exist.



- Handle molded parts with care. Undue weight or pressure may cause them to break and the broken pieces may cause injury.
- To perform work safely and securely, be sure to prepare a step which is in a secure and stable condition. Performing work without using the step can cause violent falling down accidents.
- Make sure that the GD cable connector is inserted parallel to the plug. Improper insertion may cause damage to the connector and present a fire risk.

When carrying out the assembling and installation, follow the following 4-item sequence.

- 1 SECURING IN PLACE(ADJUSTER ADJUSTMENT)
- 2 INSTALLING THE GD-ROM DRIVE(SETTING GD-ROM DISC)
- 3 POWER SUPPLY, AND EARTH CONNECTION
- 4 TURNING POWER ON

Tools such as a Phillips type screwdriver, wrench, socket wrench and Ratchet Handle are required for the assembly work.

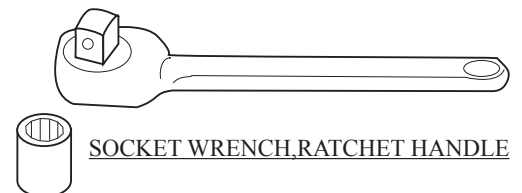
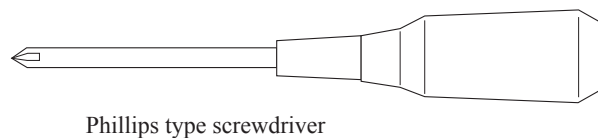
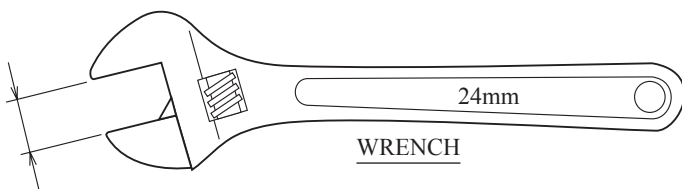

1

SECURING IN PLACE (ADJUSTER ADJUSTMENT)



Make sure that all of the adjusters are in contact with the floor. If they are not, the cabinet can move and cause an accident.

This product has 8 casters and 8 Adjusters. (FIG. 6. 2 a) When the installation position is determined, cause the adjusters to come into contact with the floor directly, make adjustments in a manner so that the casters will be raised approximately 5 mm from the floor and make sure that the machine position is level.

- Transport the product to the installation position.
- Have all of the Adjusters make contact with the floor. Adjust the Adjuster's height by using a wrench so that the machine position is kept level.
- After making adjustment, fasten the Adjuster Nut upward and secure the height of Adjuster.

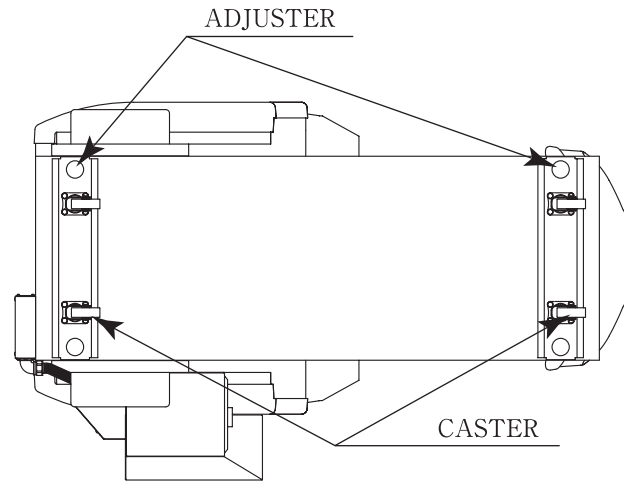

FIG. 6. 2 a BOTTOM VIEW

* Note: Picture may differ from actual unit.

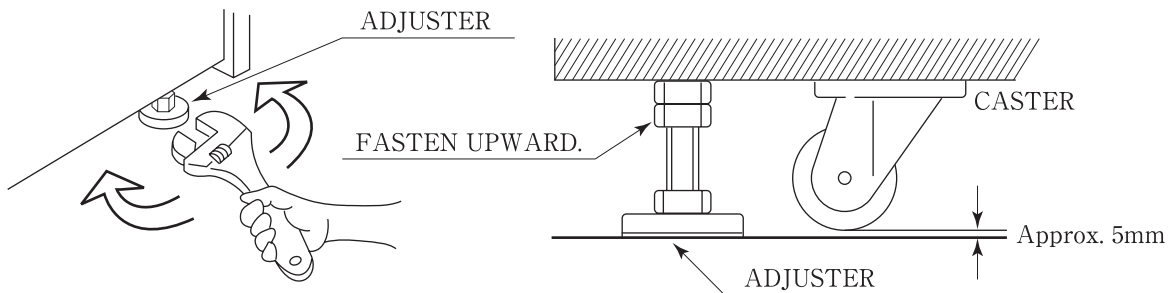

FIG. 6. 2 b ADJUSTER

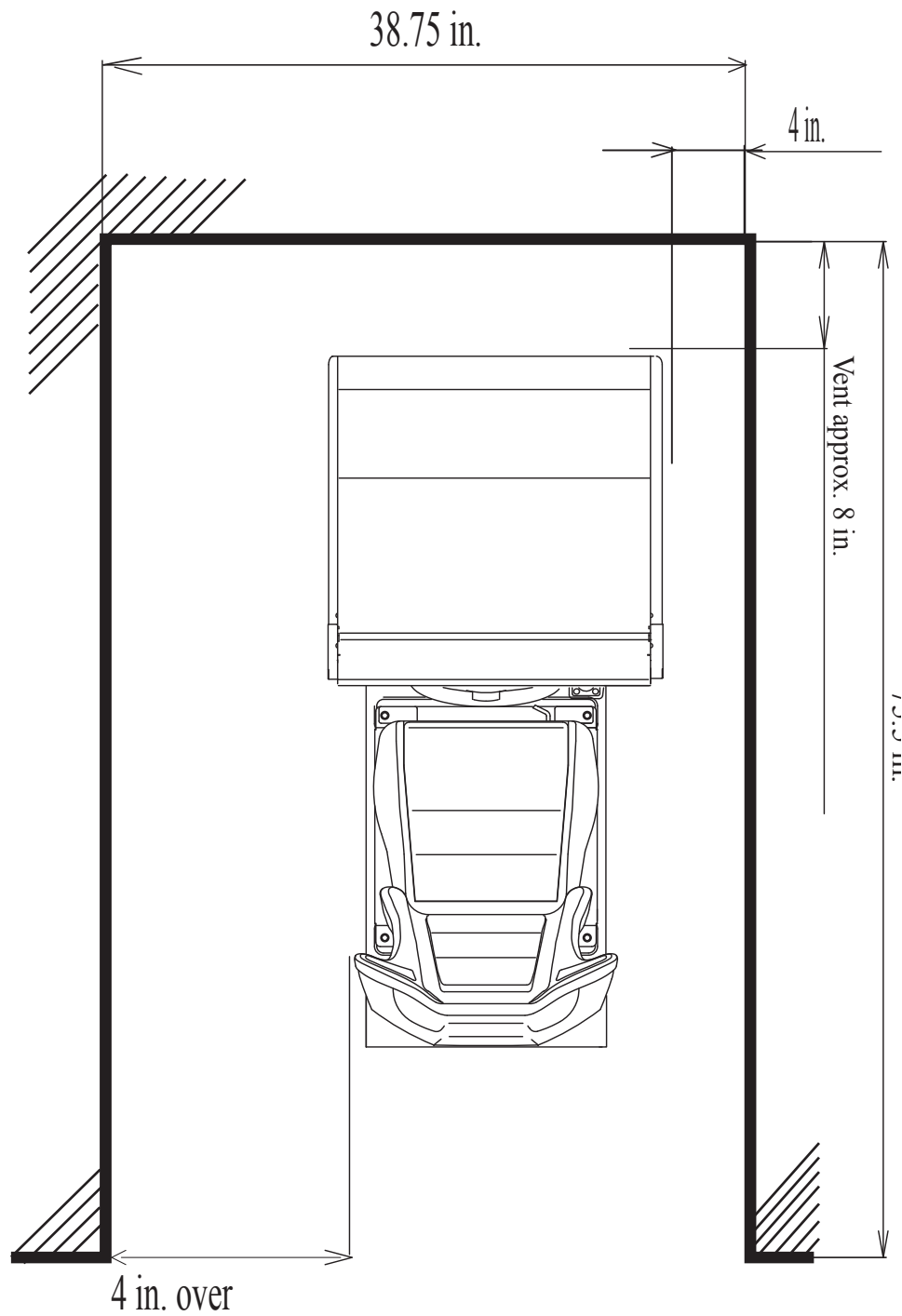

FIG. 6. 2 e
 Provide ventilation space for the ventilation opening.
 Allow more than 28 in. of space for customer traffic.

2

INSTALLING THE GD-ROM DRIVE (SETTING GD-ROM DISC)



- Carefully handle the GD-ROM drive so as not to contaminate the disc and the readout lens with stains and dust particles.
- Do not continue to use the scratched GD-ROM disc. The scratched GD-ROM disc may cause the system to malfunction.
- Set the GD-ROM disc onto the GD-ROM drive with its labeled side facing upward.
- The key chip is a precision device. Handle it carefully and avoid exposure to heat, shock and static electricity, as these may cause damage to the device.
- The key chip is contained in the GD-ROM disc case. Always use them as a set.

- Unpack the shipping crate, and take out the GD-ROM drive, GD-ROM drive bracket, and GD-ROM disc.

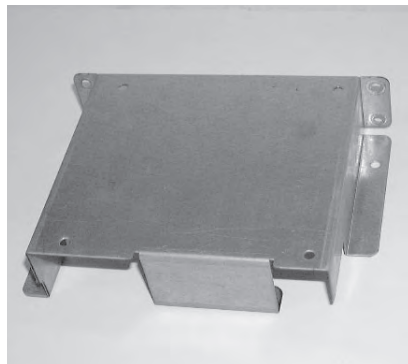

GD DRIVE BRACKET



GD-ROM DRIVE

PHOTO 6. 3 a

- Use the 4 tapping screws to fix the GD-ROM drive bracket onto the GD-ROM drive. Be careful about a fixing direction.

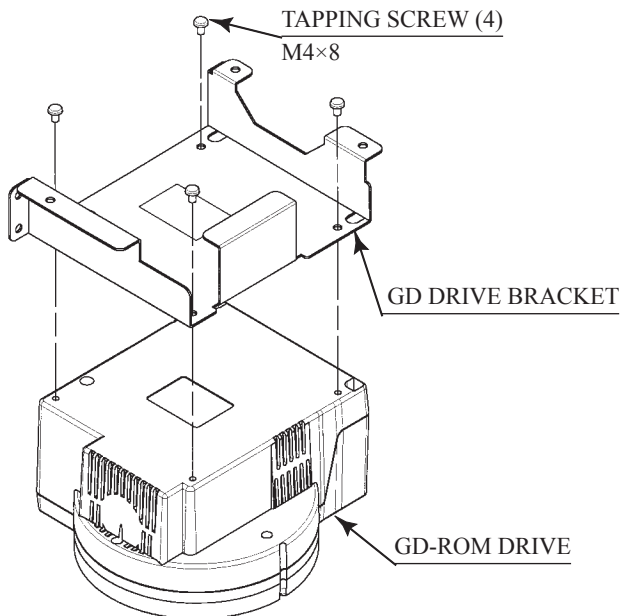

FIG. 6. 3 a

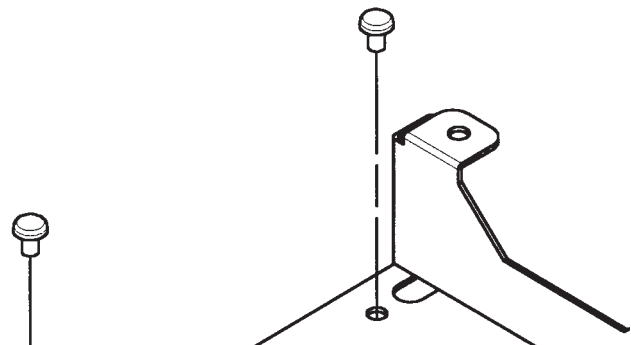

FIG. 6. 3 b

CAUTION for U. S. A., Europe, and Australia:
Attach the 2 caution stickers for a laser ray onto the GD-ROM drive.

- Remove the 1 truss head screw that fixes the GD-ROM drive lid (DISC LID). And turn clockwise the lid to remove.

TRUSS SCREW (1)
M3×8

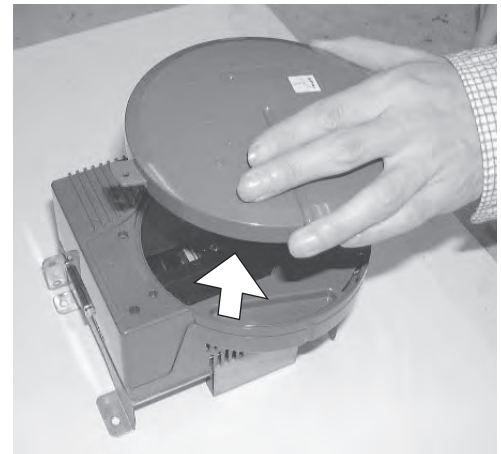
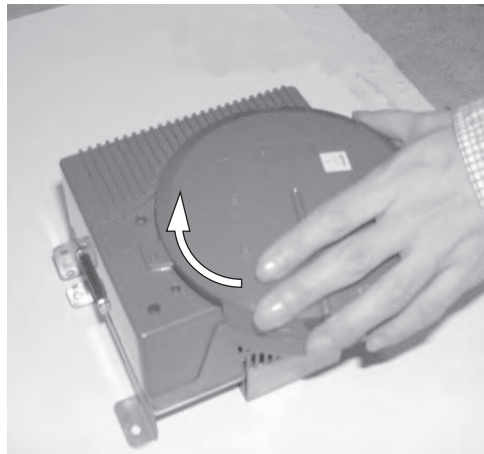
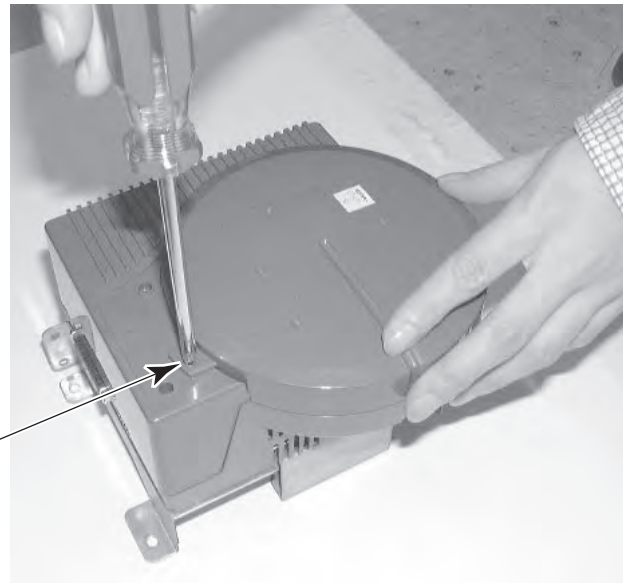

PHOTO 6. 3 b

- Set the GD-ROM disc onto the GD-ROM drive with its labeled side facing upward.
- Return the lid to its original place, and fix it with 1 truss head screw. Be careful not to fasten the screw too tightly.

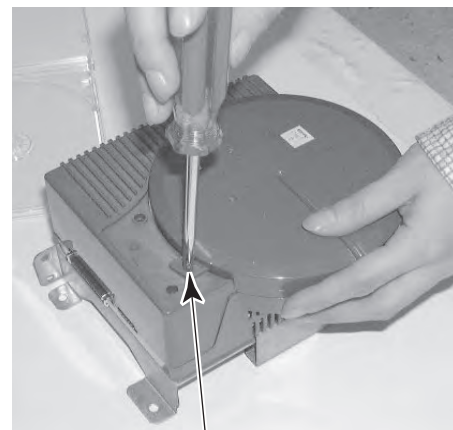

PHOTO 6. 3 c

TRUSS SCREW (1)
M3×8

- Undo the lock on the side of the unit base and remove the Truss screws.
- Turn the knob to open the lock, and lower the seat towards the backrest. Slowly lower the backrest until it touches the floor to prevent damage to the seat components. Put a drop cloth on the floor to prevent damaging the surface of the seat components.

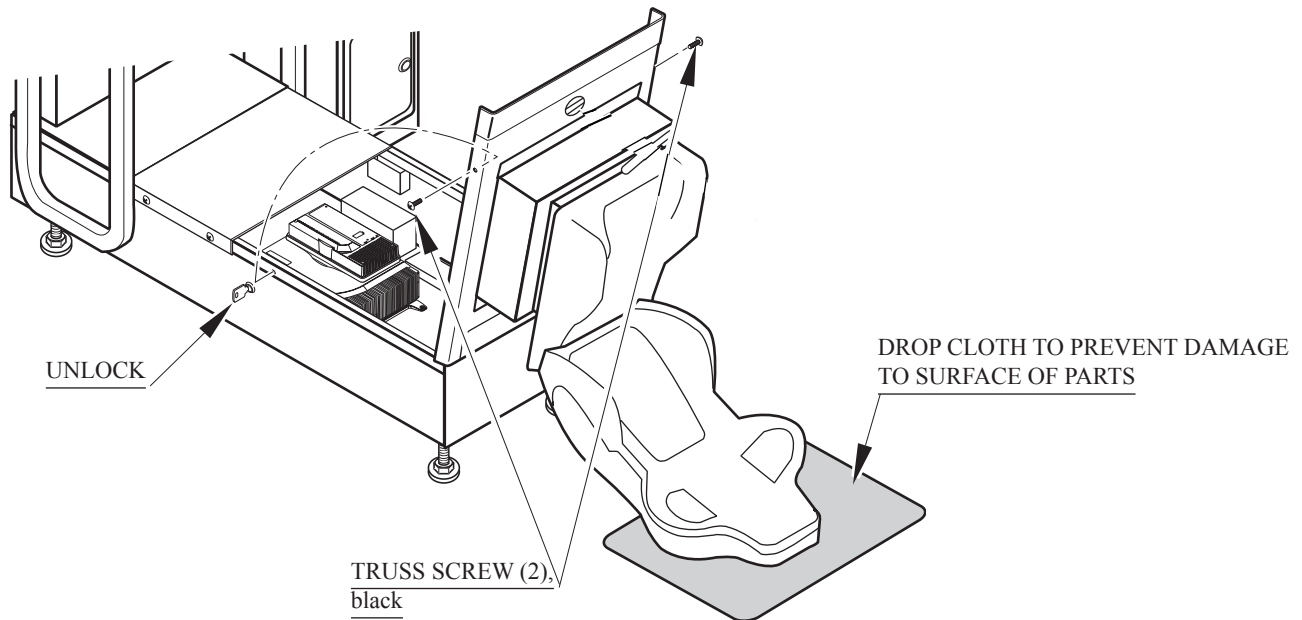

FIG. 6. 3 b

* Note Figure may appear different then actual product.

- Attach the GD-ROM drive with 3 screws.

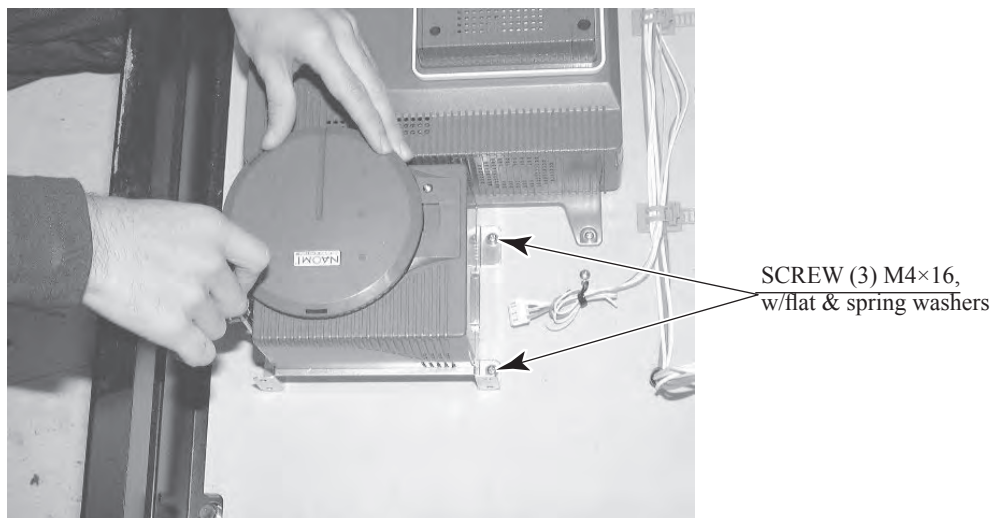

PHOTO 6. 3 d

- Connect the GD cable connector (for data communication) to the DIMM board.



PHOTO 6. 3 e

- Insert both the GD cable connector (for data communication) and the power cord connector into the GD-ROM drive. Be careful about an inserting direction in this instance. Make sure that the connectors are inserted firmly and completely. Secure the cable with the cord clamp.

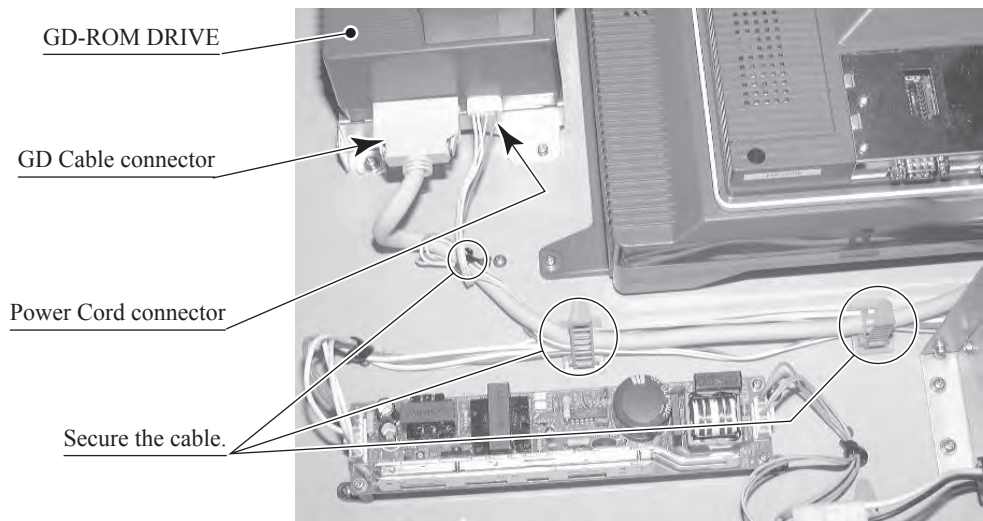

PHOTO 6. 3 f

Attach the accessory stickers to both the Game Board and the Media Board.

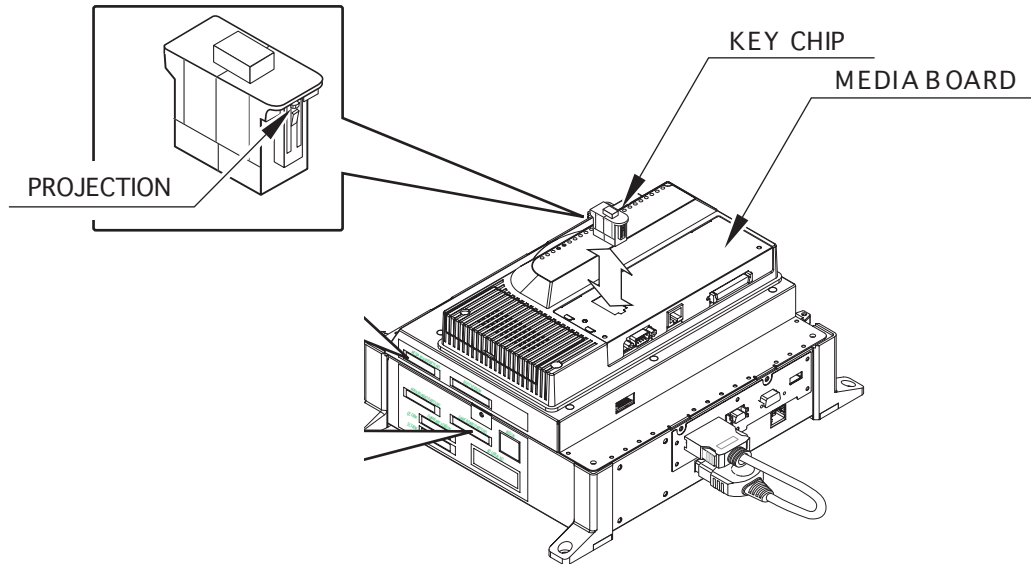

FIG. 6. 5 c

Return the ASSY MAIN BD (now installed with the GD-ROM drive) into the PTV cabinet. Following the above-described actions in a reverse order, fix the base, connect the connectors, and clamp the wires/cables.

3

POWER SUPPLY, AND EARTH CONNECTION



- Be sure to independently use the power supply socket outlet equipped with an Earth Leakage Breaker. Using a power supply without an Earth Leakage Breaker can cause a fire when electric leakage occurs.
- Ensure that the "accurately grounded indoor earth terminal" and the earth wire cable are available (except in the case where a power cord plug with earth is used). This product is equipped with the earth terminal. Connect the earth terminal and the indoor earth terminal with the prepared cable. If the grounding work is not performed appropriately, customers can be subjected to an electric shock, and the product's functioning may not be stable.
- Ensure that the power cord and earth wire are not exposed on the surface (passage, etc.). If exposed, they can be caught and are susceptible to damage. If damaged, the cord and wire can cause electric shock and short circuit accidents. Ensure that the wiring position is not in the customer's passage way or the wiring has protective covering.
- After wiring power cord on the floor, be sure to protect the power cord. Exposed power cord is susceptible to damage and causes an electric shock accident.

The AC Unit is located on one side of Cabinet. The AC Unit has Main SW, Earth Terminal and the Inlet which connects the Power Cord.

- Ensure that the Main SW is OFF.

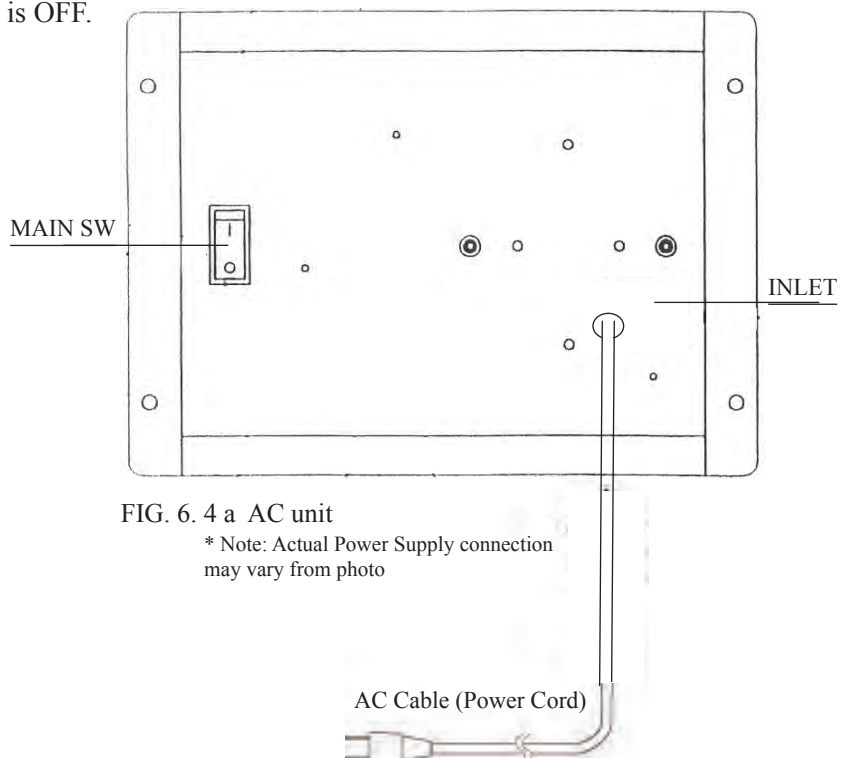
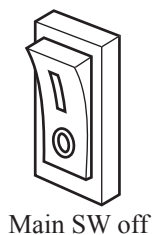

FIG. 6. 4 a AC unit

* Note: Actual Power Supply connection may vary from photo

4

TURNING POWER ON

Turn on the AC unit's main switch to supply power to the unit. Once power is turned on, the fluorescent lamp lights up. The Start System Screen displays after a lapse of several seconds. It is followed by the screen that indicates that the network is currently being checked if the communication mode has been set. If there is a bad or improper communication connection, each screen will not proceed to the next, remaining on the currently Network Check Screen. If this occurs, resolve the error according to the instructions in this document.

If the communication mode has not been set or the communication check ends normally, the Motor Check Screen returns. While the Motor Check Screen is on-screen, the steering wheel can move either clockwise or counterclockwise. If you touch the wheel, the motor check is hindered and the game will not operate normally. So, you must not touch it at this time. Failures are displayed, if found. Resolve the errors according to the instructions in this document.

Once all the above steps have been completed, the Advertise Screen displays and voices are output through the left and right loudspeakers, unless you have set the machine so that no voices are output during the Advertise mode.

This product retains the number of credits and the ranking data even after the power is turned off. It does not retain data about the fractional number of coins (i.e., the number of coins not reaching one credit) or the bonus adder count.

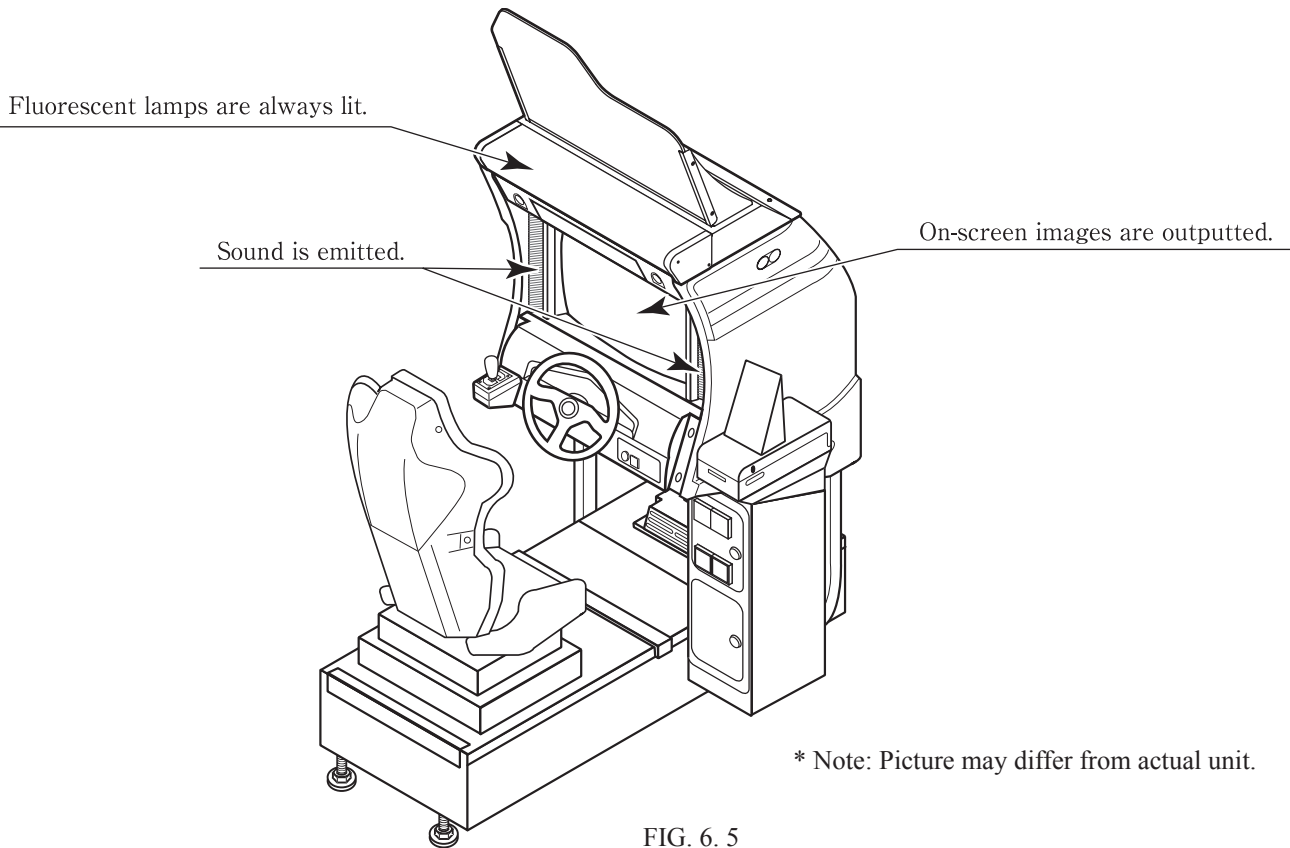

7. PRECAUTIONS WHEN MOVING THE MACHINE



- When moving the machine, be sure to unplug the power plug. Moving the machine with the plug as is inserted can damage the power cord and cause fire and electric shock hazards.
- When moving the machine on the floor, retract the Adjusters and ensure that Casters make contact with the floor. During transportation, pay careful attention so that Casters do not tread power cords and earth wires. Damaging the power cords can cause electric shock and short circuit hazards.
- Do not push the cabinet from the left/right when attempting to move the unit. Pushing from the sides may cause the unit to tip and result in injury and damage to parts.



Do not push on any parts made of glass (e.g. CRT screen) or plastic, as these parts may break and result in bodily injury.

**** Note: Image differs from actual product.**

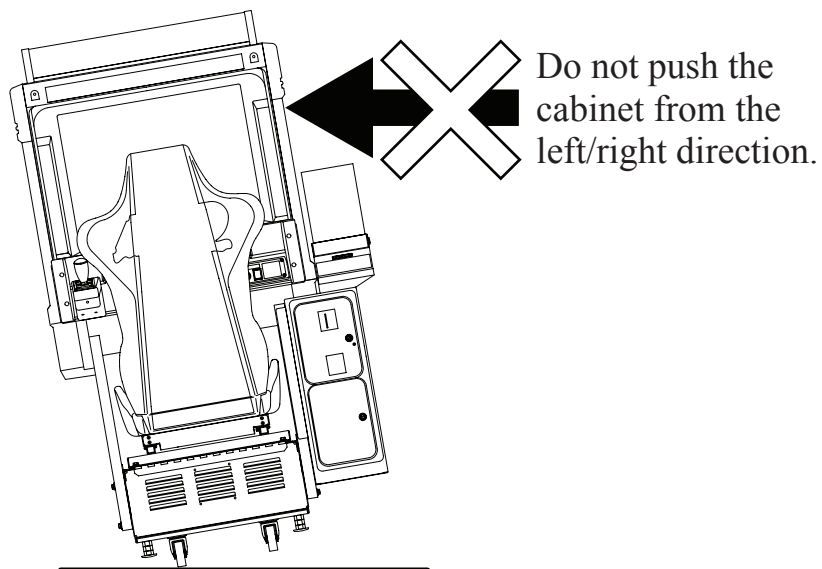

FIG. 8 a

8. Game Description

Basic Controls

Insert a coin and press the Start Button to begin a game.
 Choose your car, background music, and other options. View choices with the Steering Wheel, and enter you selection with the Gas pedal.

During game play, use the Gas pedal to accelerate your car, and the Brake pedal to stop.
 The Gear Shifter can be used to shift up and shift down when using Manual Transmission.

You can switch between three different view settings with the View Change Button.

Game Outline

This is a driving game.
 The player controls a car (Ferrari), listening to great music and enjoying roadside scenery in the company of a gorgeous female passenger, all while racing towards the goal before time is up.
 The time limit is extended at each checkpoint.
 The game ends when the player runs out of time or reaches the goal,

Each game stage ends with a fork in the road where the player must decide the route using the car during the race. There are a total of fifteen stages, and five separate goal areas.

The three single player game modes are OutRun Mode, HeartAttack Mode, and Time Attack Mode.

The games' Versus Mode accommodates play for up to four players.

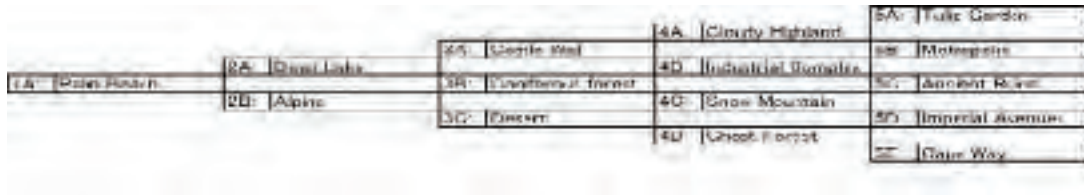

- 1A: Palm Beach
- 2A: Deep Lake
- 2B: Alpine
- 3A: Castle Wall
- 3B: Coniferous Forest
- 3C: Desert
- 4A: Cloudy Highland
- 4B: Industrial Complex
- 4C: Snow Mountain
- 4D: Ghost Forest
- 5A: Tulip Garden
- 5B: Metropolis
- 5C: Ancient Ruins
- 5D: Imperial Avenue
- 5E: Cape Way

1. Versus Mode Entry

After inserting coins and pressing the Start Button, Versus Mode Entry prompts will be displayed for potential players at other game cabinets. Pressing the Start Button within the Versus Mode Entry period will start Versus Mode.

Closing Versus Mode Entry

To close Versus Mode entry, press the View Change Button and the Brake pedal at the same time before other players join. (Press the Brake pedal while holding down the View Change Button.)

Versus Mode entry time can also be run down to “0” by holding the Start Button, thus closing Versus Mode entry.

By closing Versus Mode entry in either of the above ways, the Single Player mode will commence, provided no players have already joined.

2. Car Selection



You can select the car model. In Single Player mode you can also change the car color. Press the Brake pedal and Shifter together to change the car color. (Press up or down on the shifter while holding down the Brake pedal.) These instructions will not be displayed on the screen.

Moving the Shifter up or down while holding down the Brake pedal will bring up a two-character car color code just above the ‘Gas Pedal: Enter Selection’ indicator in the lower right corner of the screen. The color codes are represented as follows: RE:red, YE:yellow, BK:black, WH:white, SL:silver, GR:green, LB:light blue, BU:blue.

Changing the car model in the middle of color selection will automatically return the color to the selected model's default color, after which model and color selection will again be possible.
The selected car will then be displayed in the chosen color at the start of the game.

The available colors vary from car to car. The colors available for each car are indicated by a 'Yes' in the chart below, and likewise, only these colors will be shown during selection.

Color Chart

Car Type	Black	Blue	Green	Light Blue	Red	Silver	White	Yellow
F50	Yes	Yes	Yes	Yes	Yes	Yes	Yes	Yes
360 Spider	Yes	Yes	Yes	Yes	Yes	Yes	Yes	Yes
Dino 246 GTS	Yes	No	No	Yes	Yes	Yes	Yes	Yes
365 GTS/4 Daytona	Yes	No	No	Yes	Yes	Yes	Yes	Yes
Testarossa	Yes	No	No	No	Yes	Yes	No	Yes
288 GTO	Yes	No	No	Yes	Yes	No	Yes	Yes
Enzo Ferrari	Yes	No	No	No	Yes	Yes	No	Yes
F40	Yes	Yes	Yes	Yes	Yes	Yes	Yes	Yes

Player-selectable cars and their characteristics are shown below.
The color shown in parenthesis is the default color.

✧ F50 (RE), 360 Spider (RE)
(For INTERMEDIATE Player)
Acceleration : *****
Handling : *****
Top Speed : *****

✧ Dino 246 GTS (YE), 365 GTS/4 Daytona (BK)
(For NOVICE Player)
Acceleration : *****
Handling : *****
Top Speed : *****

✧ Testarossa (RE), 288 GTO (RE)
(For INTERMEDIATE Player)
Acceleration : *****
Handling : *****
Top Speed : *****

✧ Enzo Ferrari (RE), F40 (RE)
(For PROFESSIONAL Player)
Acceleration : *****
Handling : *****
Top Speed : *****

3. Transmission Selection

You can choose between Automatic transmission and Manual transmission.

When Manual transmission is selected, the number of gears varies with the car model.

- 6-speed: F50, 360 Spider, Enzo Ferrari
- 5-speed: Dino 246 GTS, 365 GTS/4 Daytona, Testarossa, 288 GTO, F40

4. Mode Selection

In Single Player, you will choose a game mode.

(1) OutRun Mode

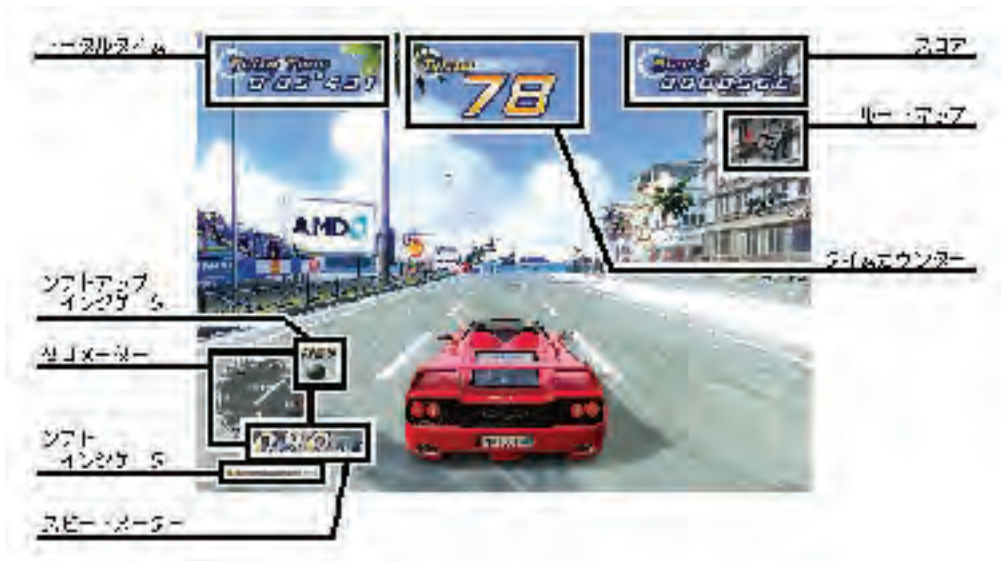

- 1) Total Time
- 2) Time Counter
- 3) Score
- 4) Route Map
- 5) Tachometer
- 6) Shift Up Indicator
- 7) Speed Meter
- 8) Shift Indicator

This is the pure driving mode, enjoyed with a young lady by your side. You select branching paths and try to reach the goal within the time limit. The game ending varies depending on which goal is reached.

(2) Heart Attack Mode



1) Lady's Heart Meter

This is the mode where you raise the Lady's Heart Meter by fulfilling her requests. Collect as many of the hearts showing her feelings as possible. You must pursue her request for the duration of the indicated track section.

☉The Lady's Requests

- 'Drift more!'

Try drifting continuously throughout the track section.

- 'Keep passing cars!'

Pass as many cars as possible throughout the track section.

- 'Don't crash!'

Avoid hitting any other cars, walls, or obstacles throughout the track section.

- 'Run through red/blue!'

Drive on the indicated color section of the roadway.



- 'Hit the blue cones!'

There are twenty blue cones placed on the roadway—try to hit as many as you can.



- 'Cut the line!'

Drive through the yellow heart lines between cars on the roadway. Lines cut once will not come back.



- 'Catch the Heart!'

There are Hearts floating around on the roadway. Try your best to drive through the Hearts. Hearts collected once will not come back.



⊗ Special Requests

Satisfying certain conditions will open up Special Requests.

⊗ Ending

The game ending will change depending on your performance assessment.

(3) Time Attack Mode



1) Sector Time

2) Position

This mode is a test of time in reaching the goal.

Player driving data is recorded for goal time, route best time, and slowest time. The player can then compete against his own time in subsequent plays.

When there is no player data recorded, a default data car will appear.

⊗ Ending

The game ending will change depending on your goal time.

⊗ Internet Ranking Password

If your time qualifies, you'll be given an Internet Ranking password. Using this password, you can participate in the Internet Ranking system.

⊗ Goal Choice

You can choose from five different destination goal points.
(This option is only available in the Time Attack Mode.)

⊗ Route Choice

After choosing a goal, you can decide on a specific route for that particular goal.
(This option is only available in the Time Attack Mode.)

There is one exception, however—Goal A, ‘Tulip Garden’, and Goal E, ‘Cape Way’ each have only one route so the Route Choice option will not be available.

Goal B, ‘Metropolis’, and Goal D, ‘Imperial Avenue’ each have four possible routes, while Goal C, ‘Ancient Ruins’ has six possible routes to choose from.

🎵 BGM Selection

There are seven different in-game songs to select from. In Versus Mode, each player can listen to his or her own individual selection.

- SPLASH WAVE(from original OutRun)
- MAGICAL SOUND SHOWER(from original OutRun)
- PASSING BREEZE(from original OutRun)
- Risky Ride(new)
- Shiny World(new)
- Night Flight(new, includes lyrics)

Versus Play

1. Versus Mode Game Play

The car colors for versus mode are fixed for each player. 1P: Red, 2P: Yellow, 3P: White/Silver (depending on car model), 4P: Black

The position order on the starting grid is determined by the order of Versus Mode entry (decided by who presses the Start Button first).

The course is decided as the route taken by whoever first reaches a given course branch.

2. Special Versus Mode Commands

The ‘No Handicap’ and ‘Player Only’ modes are selectable with special commands entered at the game’s selection screen.

(1) No Handicap Mode

In the usual Versus Mode, the player in second place during a race can catch up easier with computer assistance, but this assistance isn’t available in the No Handicap mode.

To activate No Handicap mode, all participants in the Versus Mode competition must press the Brake pedal together with the Shifter up. (Push the shifter up while holding down the Brake pedal.) An icon will be displayed on the right side of the selection screen when this mode is activated.



(2) Player Only Mode

In Player Only mode, no cars besides the player-controlled cars will appear in the race.

To activate Player Only mode, all participants in the Versus Mode competition must press the Brake pedal together with the Shifter down. (Push the shifter down while holding down the Brake pedal.) An icon will be displayed on the right side of the selection screen when this mode is activated

Gameplay Techniques and Secret Commands

1. How to Drift



After letting go of the Gas pedal, immediately press the Brake pedal. Then, quickly steer sharply into the turn and press the Gas pedal.

In the case of Manual transmission, shift down one gear just before the turn, then immediately steer sharply into the turn.

2. Mid-game Quit Command



You can quit in the middle of a game. This command is only possible in the Single Player mode.

To activate the mid-game quit command, stop the car and press the Brake pedal, View Change button, and Shifter up. (While holding down the Brake pedal, continue to hold down the View Change button, and finally press the Shifter up.)

After inputting the command, the player is prompted, 'Do you really want to quit this game? Yes/No'. Choosing 'Yes' will finish the game, and 'No' will return the player to the game.

There are three conditions under which this command cannot be executed.

- The player is near the starting grid.
- The remaining time is under 8 seconds.
- 'No' has already been chosen once.

Gameplay Techniques and Secret Commands

1. Driver

Name: Alberto

Personal Info: Although easy-going on the outside, he's a real go-getter.
He has a very distinguished driving sense. He's also quite rich.

2. OutRun Mode Lady

Name: Jennifer

Personal Info: She's a filthy rich 'princess', always selfishly seeking the next thrill. She's involved with Alberto, his Ferrari a present from her. She has a sharp eye for driving techniques.

3. Heart Attack Lady

Name: Clarissa

Personal Info: She's peppy and unmistakably sexy. A driving fan, with a weakness for thrill rides.
She's very demanding, but her sweet character makes her hard to dislike.

9. Game Test Mode

[IMPORTANT]

When changing the game configuration, changes will not be enabled until the Game Test Mode has been completed. Be sure to exit the Game Test Mode properly after configuration changes.

Select GAME TEST MODE from the System Menu screen to display the Game Test Menu screen as follows. Use the SERVICE Button to move the cursor to the desired test item. Press the TEST Button to enter the selected item.

NOTE: In Upright cabinet types, the DRIVE BOARD TEST is not necessary and the option will not be displayed.

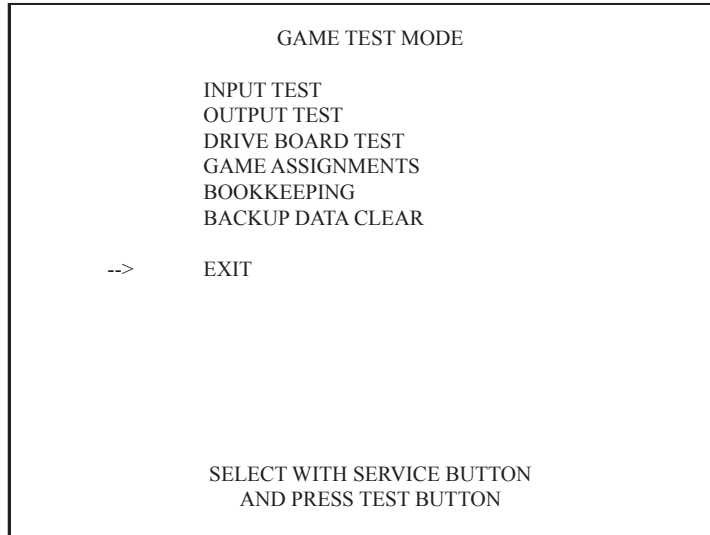

<GAME TEST Menu screen>

After selecting an item, read the explanations below regarding operation.

After the test is complete, move the cursor to EXIT and press the TEST Button to return to the System Menu screen.

A. INPUT TEST

Select INPUT TEST to display the following screen and check the status of input devices. This test should be used periodically to check that each input device is functioning correctly.

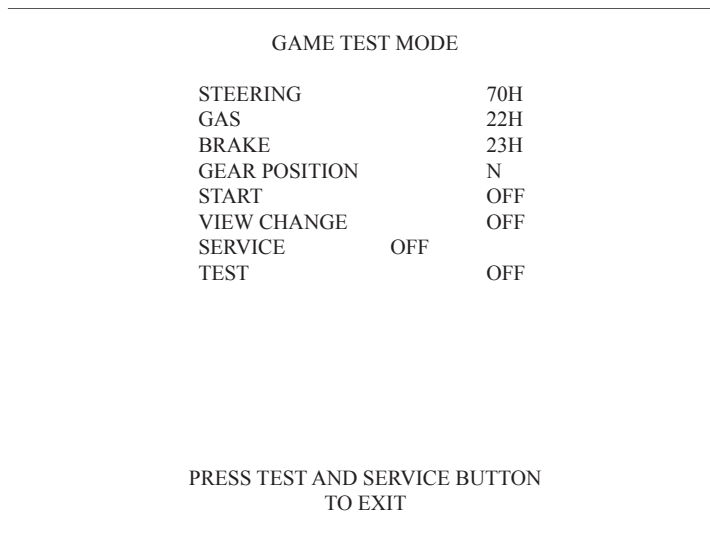

<INPUT TEST screen>

Test the STEERING, GAS (ACCEL) and BRAKE controls to ensure that they are functioning properly and that the parameters change smoothly as each input device is operated.

Display N, UP and DOWN using the GEAR POSITION. N displays that there is no control input. Verify that both UP and DOWN display in sync with the position of the shift knob.

Press the START, CHANGE VIEW, SERVICE and TEST Buttons. If functioning correctly, each indicator will switch from OFF to ON.

Press the SERVICE and TEST Buttons simultaneously to return to the Game Test Menu screen.

B. OUTPUT TEST

Select OUTPUT TEST to display the following screen and check the status of each lamp. This test should be used periodically to check that the lamps are functioning correctly.

On this screen the cursor will switch automatically between items, lighting up the respective lamps.

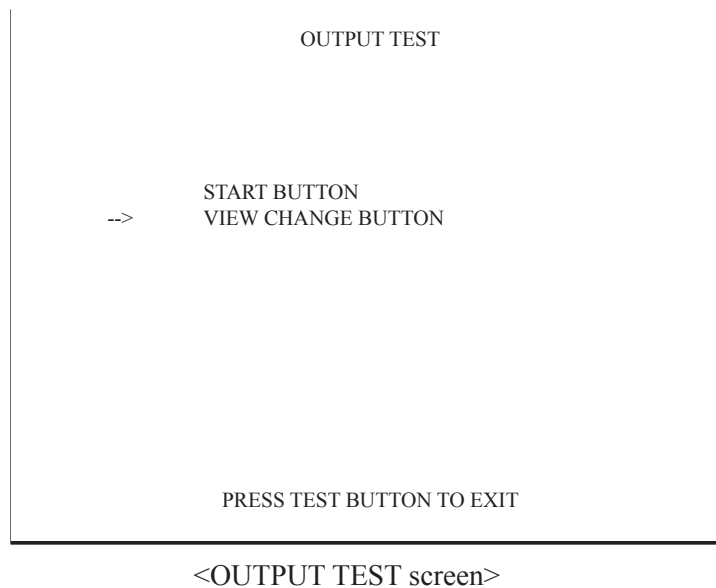

- START BUTTON : Lights up the START button.
- VIEW CHANGE BUTTON: Lights up the View Change button.

Press the TEST Button to return to the Game Test Menu screen.

C. DRIVE BOARD TEST

Select DRIVE BOARD TEST to display the following screen and check the status of steering motor.

Use the SERVICE Button to select the desired test item. Press the TEST Button to activate the selected item.

NOTE: This test will not be displayed in Upright cabinet types.

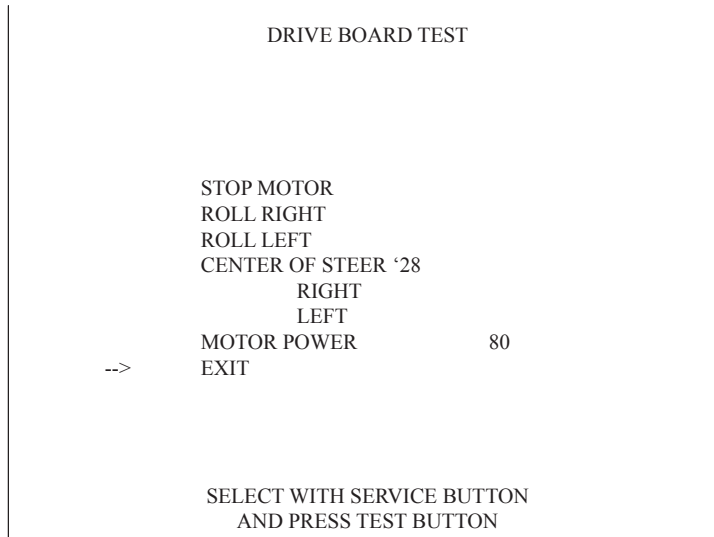

<DRIVE BOARD TEST screen>

- STOP MOTOR: Halts motor activity.
- ROLL RIGHT: Rotates steering wheel completely to the right.
- ROLL LEFT: Rotates steering wheel completely to the left.
- CENTER OF STEER: Steering wheel motor's center of control is displayed.
 - :RIGHT: Moves center of control position to the right.
 - :LEFT: Moves center of control position to the left.
- MOTOR POWER: Sets the steering resistance.
 - There are four levels to choose from, 100% (strong resistance), 90%, 80%, and 60%(weak resistance). (80% is the default setting)

After changing the settings, select EXIT and press the TEST Button to return to the Game Test Menu screen.

D. GAME ASSIGNMENTS

Select GAME ASSIGNMENTS to display the current game settings and make changes.

Changes to settings are not enabled until Test Mode is exited. After changing settings, be sure to exit Test Mode.

NOTE: When adjusting network play settings, DIFFICULTY, ADVERTISE SOUND, LANGUAGE, SPEEDOMETER, and QUICK START items will be decided by the cabinet with LINK_ID "1". Changes made to the game display or settings during game play do not affect the Game Test Menu settings

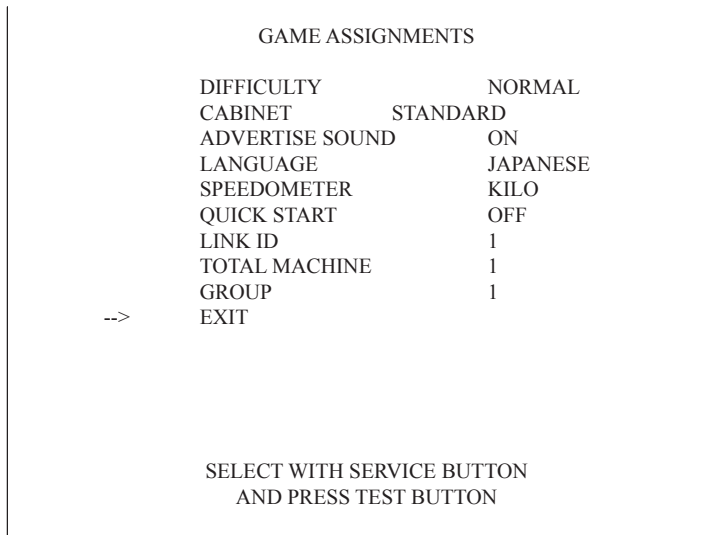

<GAME ASSIGNMENTS screen>

Perform the following settings for each item.

- **DIFFICULTY:** The game difficulty setting. There are 5 difficulty levels with VERY EASY being the easiest setting and VERY HARD being the most difficult setting. (Default Setting: NORMAL)
- **CABINET TYPE:** The game cabinet type setting. Choose from either STANDARD or UPRIGHT.
- **ADVERTISE SOUND:** The setting to turn the advertising sound ON/OFF. (Default Setting: ON)
- **LANGUAGE:** The game language setting. Choose from either JAPANESE or ENGLISH. (With JAPAN as the Country Setting, the default LANGUAGE setting is JAPANESE. ENGLISH is set as the default for a Country Setting of USA or EXPORT.)
- **SPEEDOMETER:** The speed display setting. During game play, KILO will be displayed as “km/h”, and MILE as “mph”. Choose one of these options. (With JAPAN or EXPORT as the Country Setting, the default SPEEDOMETER setting is KILO (km/h). MILE (mph) is set as the default for a Country Setting of USA.)
- **QUICK START:** Choose OFF or ON. The ON setting takes the player directly to the game selection screen after entering credits into the machine. (Default Setting: OFF)
- **LINK_ID:** The setting which determines the Player Number of each cabinet. It assigns unique numbers for cabinets in a single group. Do not assign two or more cabinets the same number. For network play, it is necessary to complete the LINK_ID, TOTAL MACHINE, and GROUP settings for each cabinet. (Default Setting: 1, Maximum: 4)
- **TOTAL MACHINE :** The number of network connected game cabinets. (Sets the number of competing cabinets in Versus Mode.) Setting this to “1” limits possible play modes to Single Player mode only. (Default Setting: 1, Maximum: 4)
- **GROUP:** Used for dividing networked cabinets into groups. For example, to split up a group of four networked machines into two groups of two cabinets, set two cabinets to “1” and the other two cabinets to “2”. Generally, setting all cabinets to “1” is recommended.

After changing the settings, select EXIT and press the TEST Button to return to the Game Test Menu screen.

<Network Versus Mode Cabinet Settings>

Cases for four cabinets (A, B, C, and D) connected via network cable.

4-Cabinet Versus

CABINET	A	B	C	D
LINK_ID	1	2	3	4
TOTAL MACHINE	4	4	4	4
GROUP	1	1	1	1
Status	Four cabinets can compete.			

3-Cabinet Versus

CABINET	A	B	C	D
LINK_ID	1	1	2	3
TOTAL MACHINE	1	3	3	3
GROUP	1	2	2	2
Status	Single play only.	Three cabinets can compete.		

2-Cabinet Versus

CABINET	A	B	C	D
LINK_ID	1	2	1	2
TOTAL MACHINE	2	2	2	2
GROUP	1	1	2	2
Status	Two cabinets can compete.		Two cabinets can compete.	

E. BOOKKEEPING

Selecting BOOKKEEPING will display the following screen. All up-to-date operation data will be displayed on two BOOKKEEPING screens.

Use the TEST Button to cycle between the first screen (BOOKKEEPING 1/2) and the second screen (BOOKKEEPING 2/2).

```

BOOKKEEPING 1/2

[CREDIT INFO]
COIN1:          0
COIN2:          0
TOTAL COINS:    0

COIN CREDITS:   0
SERVICE CREDITS: 0
TOTAL CREDITS:  0

NUMBER OF GAMES: 0
TOTAL TIME:     0'00"00
PLAY TIME:      0'00"00
AVERAGE PALY TIME: 0'00"00

PRESS TEST BUTTON TO CONTINUE
SELECT WITH SERVICE B UTTON
    
```

< BOOKKEEPING 1/2 screen >

- COIN CHUTE #1: The number of coins inserted into Coin Slot 1.
 - COIN CHUTE #2: The number of coins inserted into Coin Slot 2.
 - TOTAL COINS: The total number of coins inserted into the coin slots.

 - COIN CREDITS: The number of credits for the coins inserted.
 - SERVICE CREDITS: The number of credits input by the SERVICE Button.
 - TOTAL CREDITS: Total credits from coins and the SERVICE Button.

 - NUMBER OF GAMES: The total number of games played.
 - TOTAL TIME: The amount of time the unit has been in operation.
 - PLAY TIME: Total playing time.
 - AVERAGE PLAY TIME: Total play time divided by the total number of games played.
- Press the TEST Button to move to screen 2/2 of BOOKKEEPING.

```

BOOKKEEPING 2/2

[GAME MODE INFO]

OUTRUN MODE
PLAYERS: 0          GOAL PLAYERS: 0
GOAL AVE TIME: 0'00"00  SELECT AVE TIME: 0'00"00

HEART ATTACK MODE
PLAYERS: 0          GOAL PLAYERS: 0
GOAL AVE TIME: 0'00"00  SELECT AVE TIME: 0'00"00

TIME ATTACK MODE
PLAYERS: 0          GOAL PLAYERS: 0
GOAL AVE TIME: 0'00"00  SELECT AVE TIME: 0'00"00

VS MODE
PLAYERS: 0          GOAL PLAYERS: 0
GOAL AVE TIME: 0'00"00  SELECT AVE TIME: 0'00"00

PRESS TEST BUTTON TO CONTINUE
SELECT WITH SERVICE B UTTON
    
```

< BOOKKEEPING 2/2 screen >

This shows the number of plays and the respective play times. This histogram should be referred to when setting the Game Difficulty.

Press the TEST Button to return to the Game Test Menu screen.

F. BACKUP DATA CLEAR

Select BACKUP DATA CLEAR to clear the contents of BOOKKEEPING, ranking data and coin/credit data.

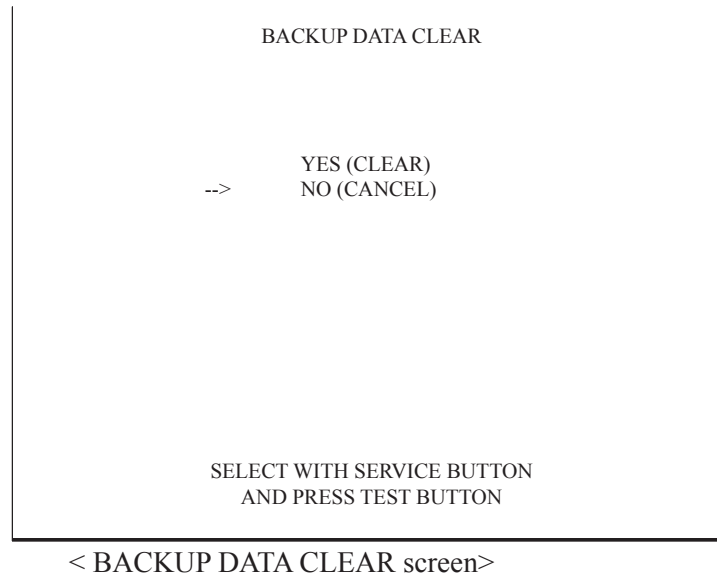

To clear data, use the SERVICE Button to move the cursor to YES (CLEAR) and then press the TEST Button. When the data has been cleared, the message “COMPLETED” will be displayed.

Press the TEST Button again to return to the Game Test Menu screen.

Move the cursor to NO (CANCEL) and press the TEST Button to return to the Game Test Menu screen without clearing the data.

Note that this operation does not affect GAME ASSIGNMENTS or GUN ADJUSTMENT settings.

10. EXPLANATION OF TEST AND DATA DISPLAY

By operating the switch unit, periodically perform the tests and data check. When installing the machine initially or collecting cash, or when the machine does not function correctly, perform checking in accordance with the explanations given in this section.

The following shows tests and modes that should be utilized as applicable.

This product's basic system consists of the Chihiro game board and the GD-ROM drive. The system enables you to play several games one after the other just by changing a GD-ROM disc that is to be set on the GD-ROM drive.

The product supports, therefore, the following 2 test modes:

- (1) System test mode for an automatic self-diagnostic test (generally used by every product that contains the basic system) and a coin assignment (specifically used by this product) and
- (2) Game test mode for testing the input/output control devices and setting the difficulty level (specifically used by this product).

TABLE 10 EXPLANATION OF TEST MODE

ITEMS	DESCRIPTION
INSTALLATION OF MACHINE	When the machine is installed, perform the following: 1. Check to ensure each is the standard setting at shipment. 2. Check each Input equipment in the INPUT TEST mode. 3. Check each Output equipment in the OUTPUT TEST mode. 4. Test on-IC-Board IC's in the self-test mode.
MEMORY TEST	This test is automatically executed by selecting RAM TEST, or ROM BOARD TEST in the Menu mode.
PERIODIC SERVICING	Periodically perform the following: 1. MEMORY TEST 2. Ascertain each setting. 3. To test each Input equipment in the INPUT TEST mode. 4. To test each Output equipment in the OUTPUT TEST mode.
CONTROL SYSTEM	1. To check each Input equipment in the INPUT TEST mode. 2. Adjust or replace each Input equipment. 3. If the problem still remains unsolved, check each equipment's mechanism movements.
MONITOR	In the Monitor Adjustment mode, check to see if Monitor (Projector) adjustments are appropriate.
IC BOARD	1. MEMORY TEST 2. In the SOUND TEST mode, check the sound related ROMs.
DATA CHECK	Check such data as game play time and histogram to adjust the difficulty level, etc.

10-1 SWITCH UNIT AND COIN METER



Never touch places other than those specified. Touching places not specified can cause electric shock and short circuit accidents.



- Adjust the sound to the optimum volume, taking into consideration the environmental requirements of the installation location.
- Removing the Coin Meter circuitry renders the game inoperable.

SWITCH UNIT

Open the coin chute door, and the switch unit shown will appear.
The functioning of each SW is as follows:

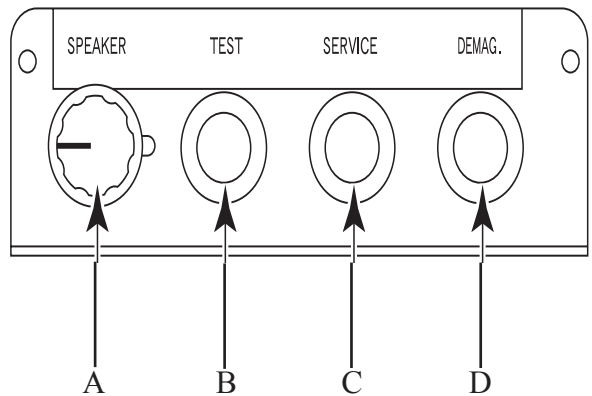

FIG. 10. 1 a SWITCH UNIT

- A **SPEAKER VOLUME SWITCH:** (VOLUME) Adjusts sound volume for all of the machines' Speakers.
- B **TEST BUTTON:** (TEST) For the handling of the test button, refer to the following pages.
- C **SERVICE BUTTON:** (SERVICE) Gives credits without registering on the coin meter.
- D **DEMAGNETIZER BUTTON:** (DEMAG) Eliminates the on-screen color unevenness due to magnetization of CRT. First use this SW before performing the monitor's color adjustment.

COIN METER

Open the Cashbox Door by using the key to have the Coin Meter appear underneath the Cashbox.

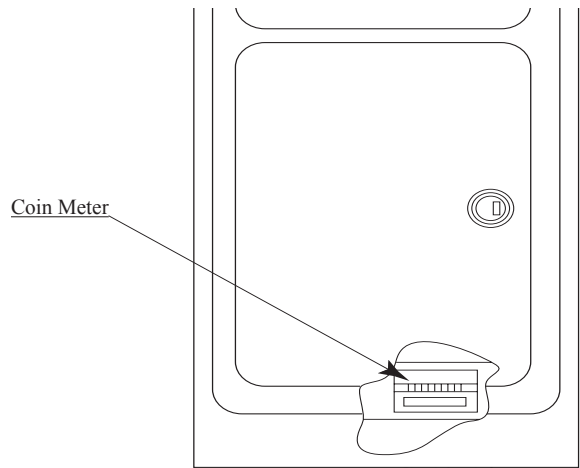

FIG. 10. 1 b

11. HANDLE MECHANISM



- In order to prevent an electric shock and short circuit, be sure to turn power off before performing work by touching the interior parts of the product.
- Be careful so as not to damage wirings. Damaged wiring can cause an electric shock or short circuit accident.

In the test mode, if the steering wheel's VR variations are not within the allowable range, the VR installation position adjustments or VR replacement is needed. Also, be sure to apply grease to the VR gear portion once every 3 months.

11 - 1 REMOVING THE CONTROL PANEL

- ① Turn the power switch off.
- ② Remove a total of 4 tamperproof screws from both sides of the control panel's front.
- ③ Remove the two tamperproof screws from the underside of the control panel.
- ④ Wiring connectors are connected inside the control panel. Carefully draw the control panel in a manner so as not to damage wiring.
Disconnect the wiring connector.
- ⑤

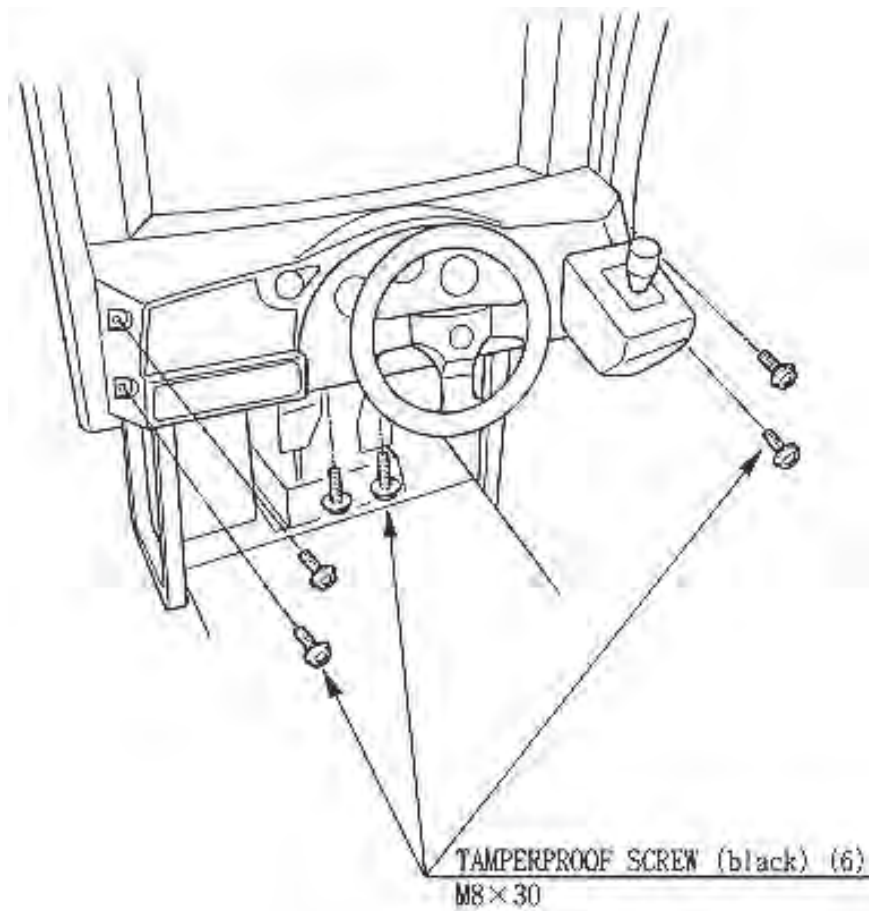

11 - 2 REPLACING AND ADJUSTING THE HANDLE'S VR



- Never touch places other than those specified. Touching places not specified can cause electric shock and/or short circuit.
- After the replacement or adjustment of the VR, be sure to set the variable value of the VR in the test mode's Volume Setting.

REPLACING THE VOLUME

- ① Turn off the power.
- ② Disconnect the connector.
- ③ Take out the 2 screws which secure the volume Bracket and remove the Volume Bracket.
- ④ Take out the 2 screws to remove the Volume Gear and replace the Volume.
- ⑤ After replacing the Volume, perform Volume setting in the Volume Setting Mode.

ADJUSTING THE VOLUME

- ① In the Test Mode, have the Volume value indicating screen displayed.
- ② Loosen the 2 screws which secure the Volume Bracket to disengage Gear Mesh.
- ③ With the Steering Wheel in the centering position, cause gears to be engaged in the manner so that the Volume Shaft is in the status shown below.
- ④ Fasten screws which secure the Volume Bracket.
- ⑤ Perform Volume setting as per the Volume Setting Mode.

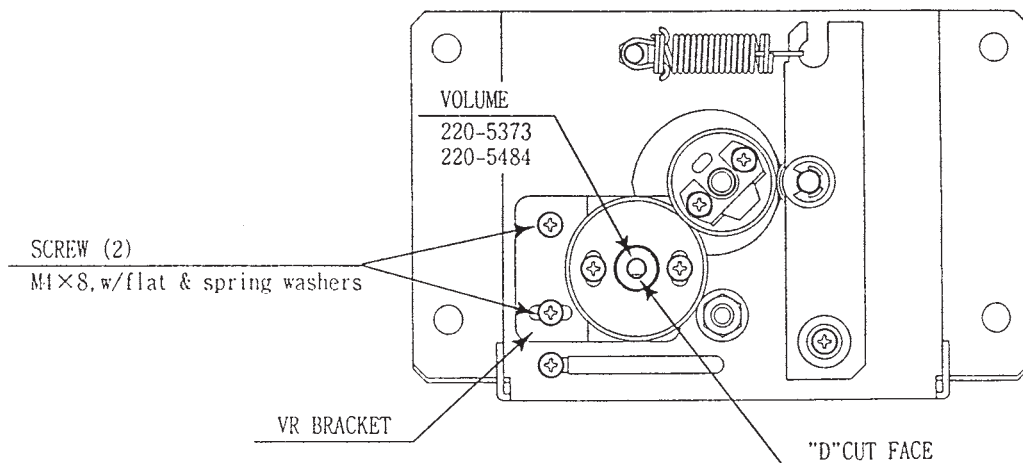

11 - 3 GREASING



- Never touch places other than those specified. Touching places not specified can cause electric shock and/or short circuit.
- After the replacement or adjustment of the VR, be sure to set the variable value of the VR in the test mode's Volume Setting.

Apply greasing to the Volume gear mesh portion every 3 months.

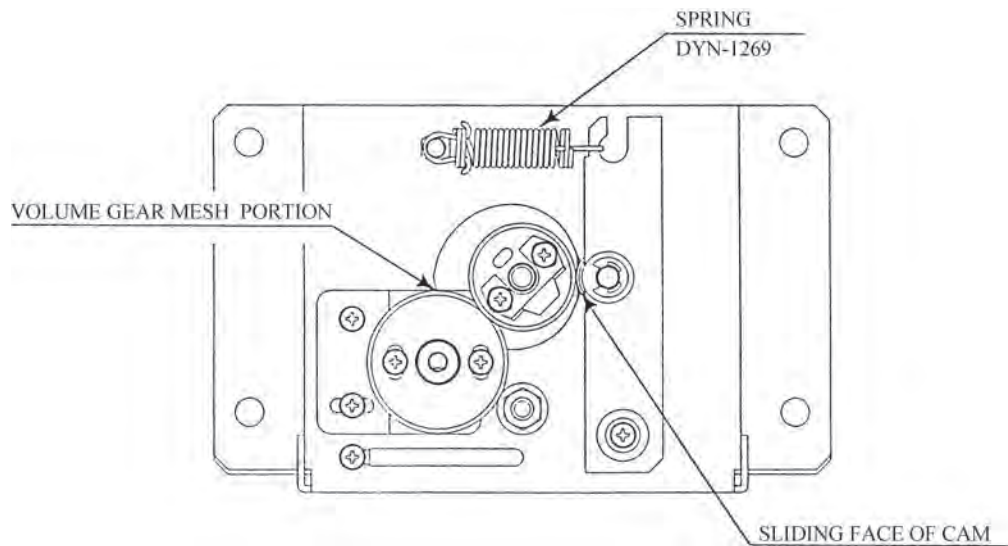

12. SHIFT LEVER



- In order to prevent electric shock and short circuit, be sure to turn off the power before performing work on the interior parts of the product.
- Be careful not to damage wiring. Damaged wiring can cause electric shock or short circuit.
- Do not touch places other than those specified. Touching places other than those specified can cause an electric shock or short circuit accident.

If the Shift Lever operation is not satisfactory, remove the Shift Lever in the following procedure and replace the micro-switch.

12 - 1 REMOVING THE SHIFT LEVER

- ① Turn Power off.
- ② Take out the 4 SPECIAL BOLTS and pull the SHIFT LEVER UNIT upward by paying careful attention so as not to damage the wiring.
- ③ Disconnect the 2 connectors to allow the unit to be removed.
- ④ When reinstalling, follow the procedure opposite as when removing. At this time, ensure that "DOWN" display appears on the upper part as shown.

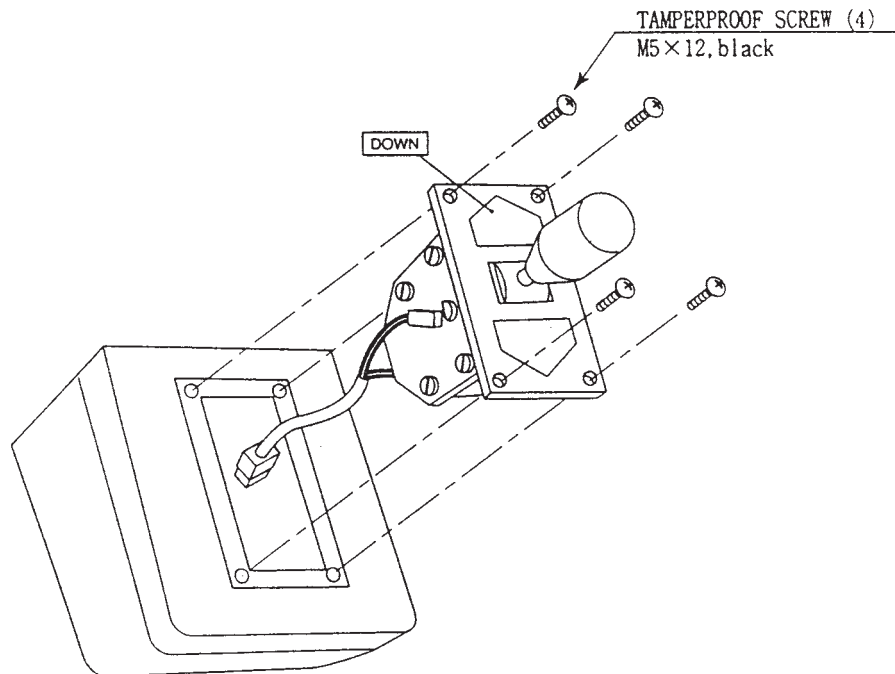

12 - 2 SWITCH REPLACEMENT

Each microswitch is secured with 2 screws. Remove the 2 screws and replace the Microswitch.

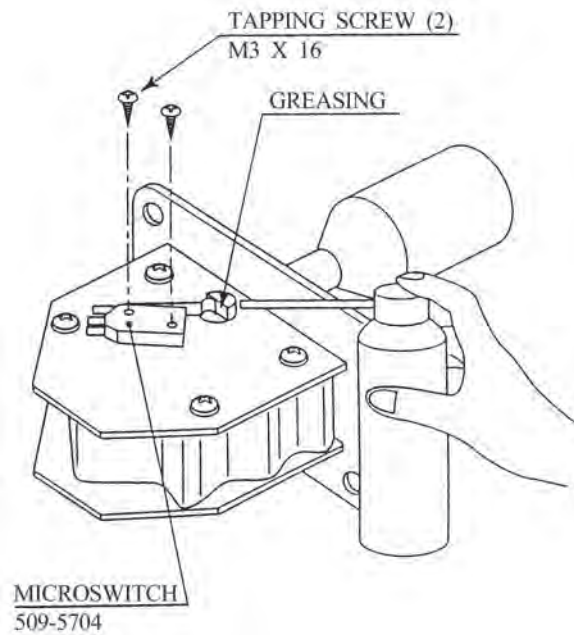

After replacing the Switch, check to see if the switch is inputted as per Shift Lever operation in the Test Mode.

13. ACCEL & BRAKE(S)



- In order to prevent an electric shock and short circuit, be sure to turn power off before performing work by touching the interior parts of the product.
- Be careful so as not to damage wirings. Damaged wiring can cause an electric shock or short circuit accident.
- Do not touch places other than those specified. Touching places not specified can cause an electric shock or short circuit accident.

If Accel and Brake operation is not satisfactory, adjustment of Volume installation position or Volume replacement is needed. Also, be sure to apply greasing to the gear mesh portion once every three months.

13 - 1 ADJUSTING AND REPLACING THE V.R.

	When released:	When stepped on:
ACCEL:	Under 30 H	Over C0H
BRAKE:	Under 30 H	Over C0H

Check Volume values in the Test Mode.

Since work is performed inside the energized cabinet, be very careful so as not to touch undesignated portions. Touching places not specified can cause an electric shock or short circuit.

- ① Take out the 2 truss screws and remove the Front Cover from the Accel. & Brake unit.
- ② Loosen the screw which secures the Potentiobase, and adjust the Volume Value by moving the Base.
- ③ Secure the Potentiobase.
- ④ Perform Volume setting in the Volume Setting Mode.

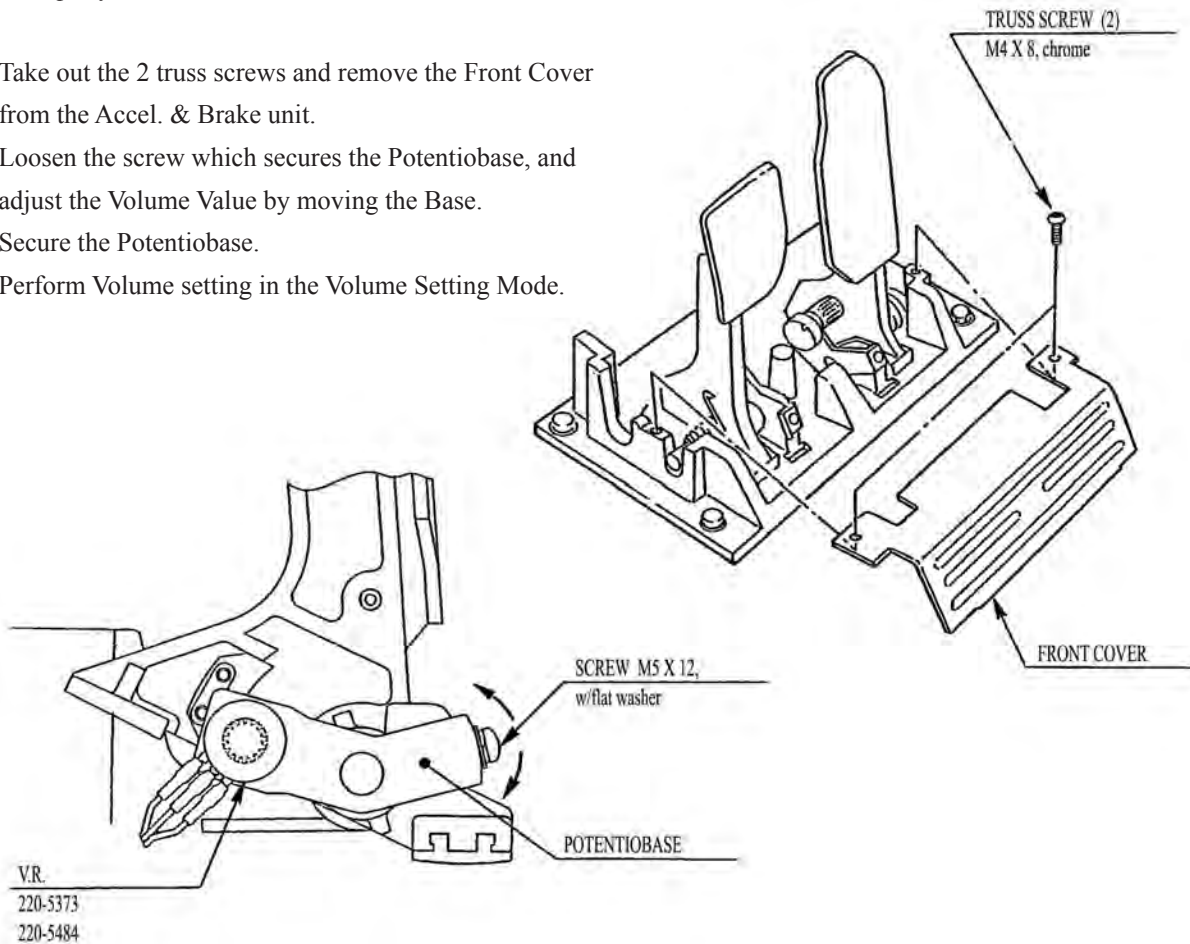

Check Volume values in the Test Mode.
Since work is performed inside the energized cabinet, be very careful so as not to touch un-designated portions. Touching places not specified can cause an electric shock or short circuit.

- ① Take out the 2 truss screws and remove the Front Cover from the Accel. & Brake unit.
- ② Loosen the screw which secures the Potentiobase, and adjust the Volume Value by moving the Base.
- ③ Secure the Potentiobase.
- ④ Perform Volume setting in the Volume Setting Mode.

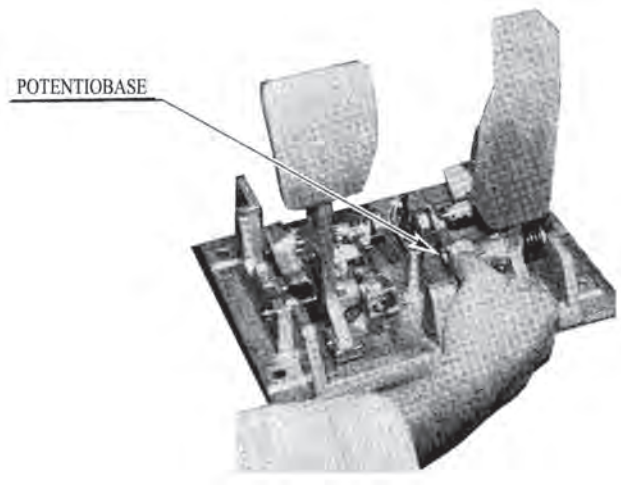
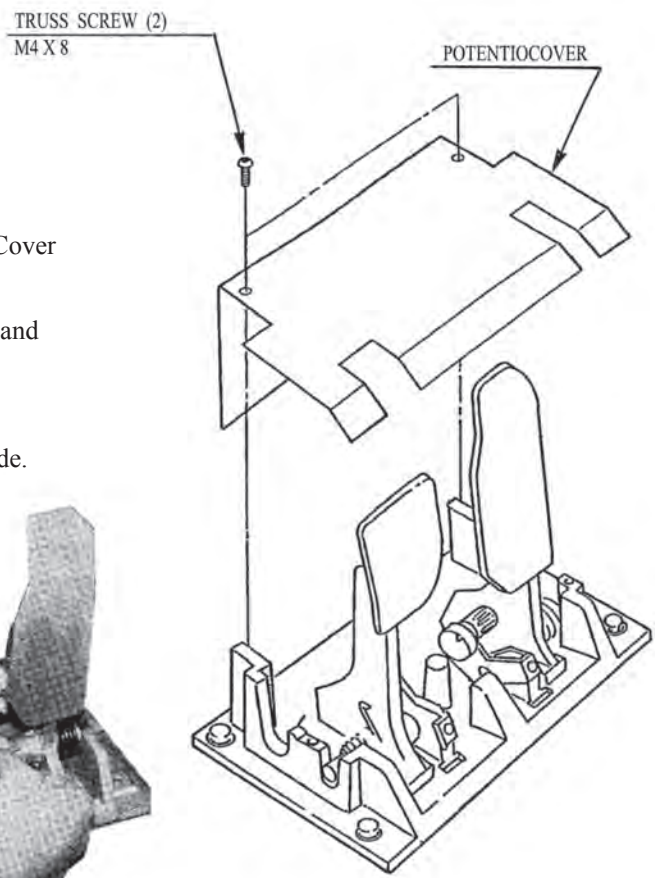

13 - 2 GREASING

Once every 3 months, apply greasing to the Spring and Gear Mesh portion.

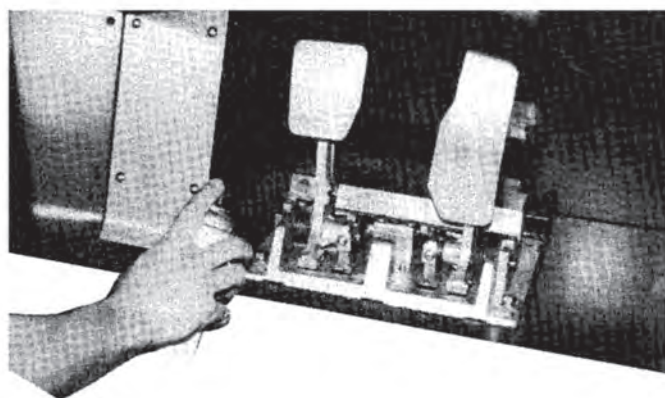

14. COIN SELECTOR

HANDLING THE COIN JAM

If the coin is not rejected when the REJECT button is pressed, open the coin chute door and open the selector gate. After removing the jammed coin, put a normal coin in and check to see that the selector correctly functions.

CLEANING THE COIN SELECTOR



- Remove and clean smears by using a soft cloth dipped in water or diluted chemical detergent and then squeezed dry.
- Never apply machine oil, etc. to the Coin Selector.
- After cleaning the Coin Selector, insert a regular coin in the normal working status and ensure that the Selector correctly functions.

The coin selector should be cleaned once every 3 months. When cleaning, follow the procedure below:

- (1) Turn the power for the machine OFF. Open the coin chute door.
- (2) Remove the coin selector from the coin chute door.
- (3) Open the gate and dust off by using a soft brush (made of wool, etc.).
- (4) Remove and clean smears by using a soft cloth dipped in water or diluted chemical detergent and then squeezed dry.
- (5) Remove the CRADLE.
When removing the retaining ring (E ring), be very careful so as not to bend the rotary shaft.
- (6) Remove stain from the rotary shaft and shaft receiving portions by wiping off with a soft cloth, etc.
- (7) After wiping off as per (6) above, further apply a dry cloth, etc. to cause the coin selector to dry completely.

COIN INSERTION TEST

Once every month, when performing the Coin SW Test, simultaneously check the following:

- Does the Coin Meter count satisfactorily?
- Does the coin drop into the Cashbox correctly?
- Is the coin rejected when inserted while keeping the Reject Button pressed down?

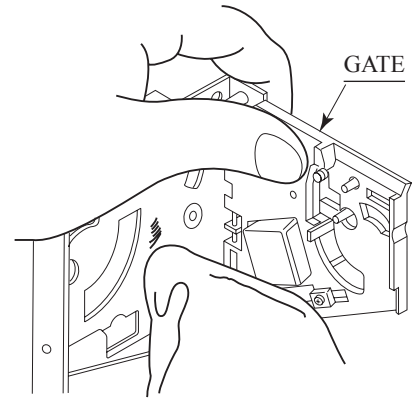

FIG. 14 a

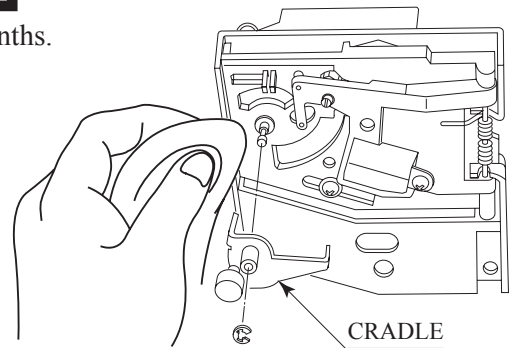

FIG. 14 b

Insert a coin while keeping the Reject Button pressed down and check if it is rejected.

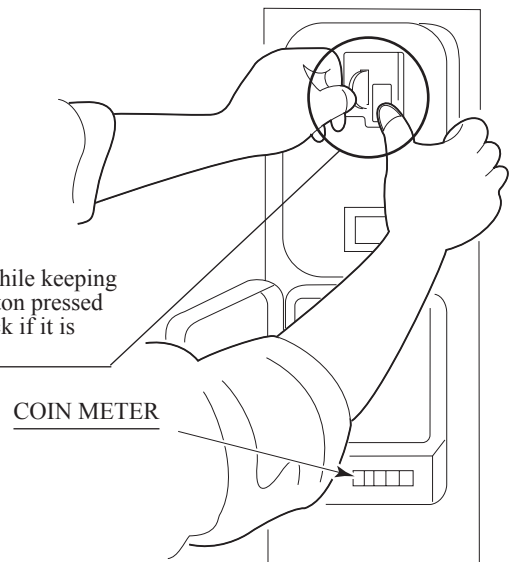

FIG. 14 c

COIN DOOR

Tom Happ
 tom.happ@happcontrols.com
 Happ Controls
 106 Garlisch Drive
 Elk Grove, IL 60007
 Ph. 847-593-6161 ext. 107
 Fx. 847-956-2091

Visit our website <http://www.happcontrols.com>

EXCLUSIVE!

Custom "Guardian" Security Hasp available to protect your dollars,



GUARDIAN

MECH HOLDER PARTS	
MECH HOLDER W/COIN SWITCH	42-3319-00
MECH HOLDER W/O COIN SWITCH	42-7355-00
COIN SWITCH	42-7087-00
SCREW FOR COIN SWITCH	43-0136-00
METAL CLIP	42-7338-91
THUMBSCREW FOR METAL CLIP	42-7338-90

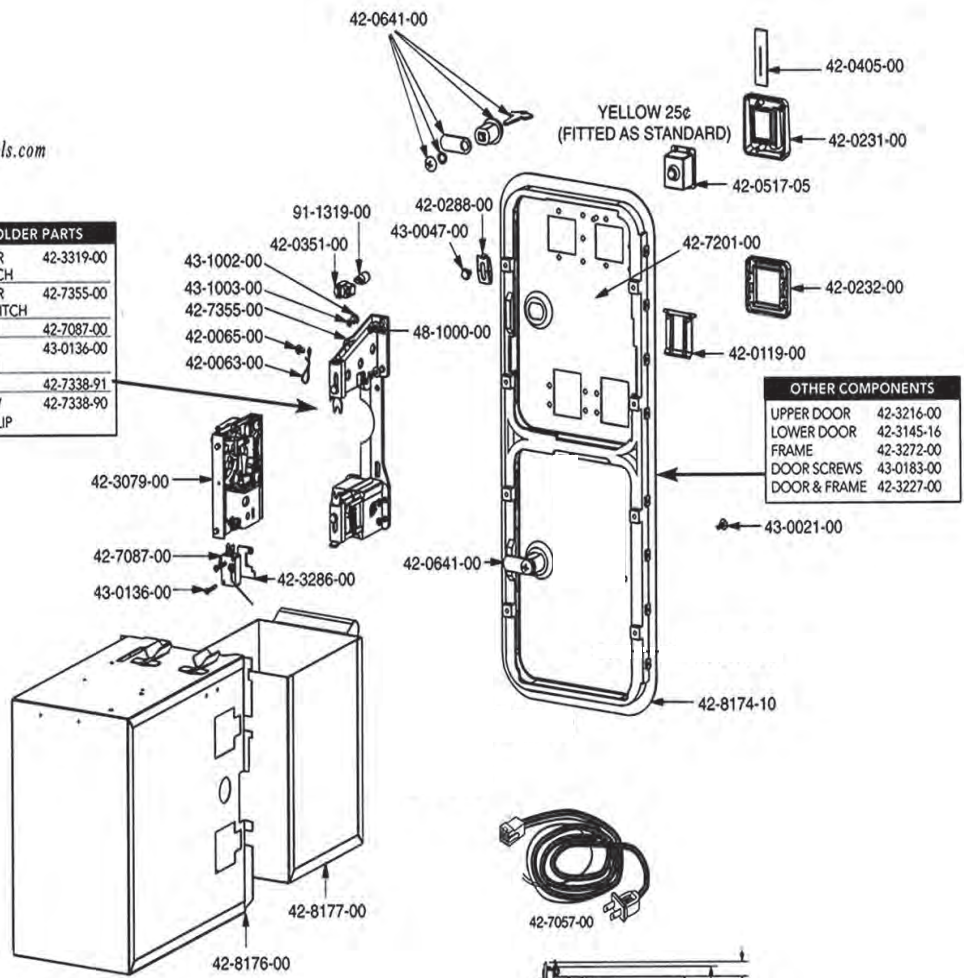

OTHER COMPONENTS	
UPPER DOOR	42-3216-00
LOWER DOOR	42-3145-16
FRAME	42-3272-00
DOOR SCREWS	43-0183-00
DOOR & FRAME	42-3227-00

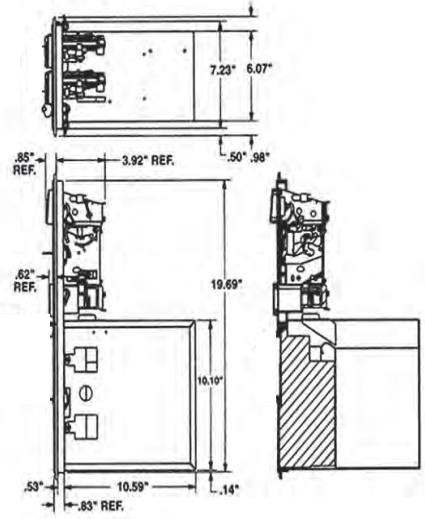
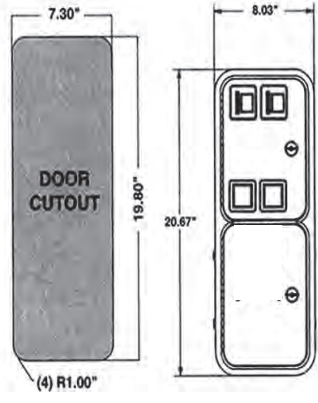
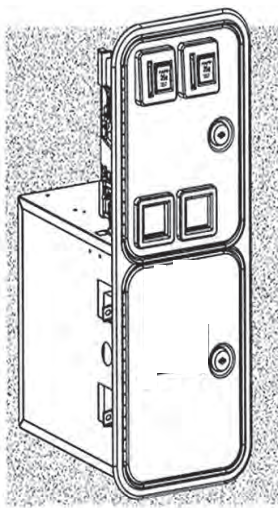

OPTIONAL DOLLAR BILL ACCEPTOR

- THE COIN DOOR ASSEMBLY USED ON **JAMBO SAFARI STD** COMES EQUIPPED TO ACCEPT A DOLLAR BILL ACCEPTOR. ALL NEEDED WIRING CONNECTIONS ARE CONVIENENTLY LOCATED INSIDE THE GAME FOR THIS APPLICATION.

- THE COIN DOOR CAN ACCCOMMODATE THE FOLLOWING VALIDATORS:

HOLE POSITION#1 (FORWARD-MOST POSITION)	Mars 2000 series
--	------------------

HOLE POSITION#2	Mars 2000 series DBV45 (JCM)
-----------------	---------------------------------

HOLE POSITION #3	CURRENTLY NOT USED
------------------	--------------------

HOLE POSITION #4	DSI01*
------------------	--------

*The back flange on the chute can be removed for hold position #4. If the flange is not removed, it may interfere with the back of the cabinet.

The frame and cashbox enclosure on this coindoor has been modified to accomodate a Mars 2000 series up-stacker. A 2000 series stacker can be added by simply removing the top two entry door and replacing it with a one entry door with a cut-out for a stacker. This one entry door can be ordered through Coin Controls or one of Coin Controls authorized distributors. The part number is 91-4000-01. The Mars stacker can be obtained through an authorized Mars distributor.

15. MONITOR

15-1 CAUTIONS AND WARNINGS CONCERNING THE SAFETY FOR HANDLING THE MONITORS

Before handling the monitors, be sure to read the following explanations and comply with the caution/warning instructions given below. Note that the caution/warning symbol marks and letters are used in the instructions.



Indicates that handling the monitors erroneously by disregarding this warning may cause a potentially hazardous situation, which could result in death or serious injury.

Indicates that access to a specific part of the equipment is forbidden.



Indicates that handling the monitors by disregarding this caution may cause a potentially hazardous situation, which could result in personal injury and or material damage.

Indicates the instruction to disconnect a power connector or to unplug.



- When performing such work as installing and removing the monitor, inserting and disconnecting the external connectors to and from monitor interior and the monitor, be sure to disconnect the power connector (plug) before starting the work. Proceeding the work without following this instruction can cause electric shock or malfunctioning.
- Using the monitor by converting it without obtaining a prior permission is not allowed. SEGA shall not be liable for any malfunctioning and accident caused by said conversion.



- Primary side and Secondary side
The monitor's circuit which is divided into the Primary side and Secondary side, is electrically isolated. Do not touch the primary side, or do not touch both the primary side and the secondary side simultaneously. Failing to observe the instruction can cause electric shock and this is very dangerous. When making monitor adjustments, use a non-conductive driver and make adjustment without touching any part other than the Adjustment V. R. and knob. Also, be sure not to cause a short-circuit to the Primary side and Secondary side. If short-circuited, it can cause electric shock or malfunctioning, which is very dangerous.
- High-tension Voltage
Some of the parts inside monitor are subject to high-tension voltage in excess of 20,000 volts and very dangerous. Therefore, do not touch the monitor interior. Should soldering & paper wastes, etc. be mixed in the monitor interior, turn the power off so as not to cause malfunctioning or fire hazard.

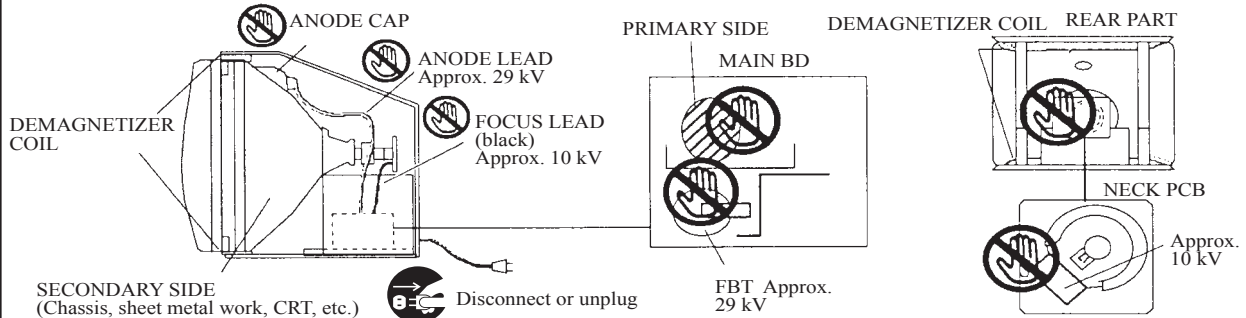
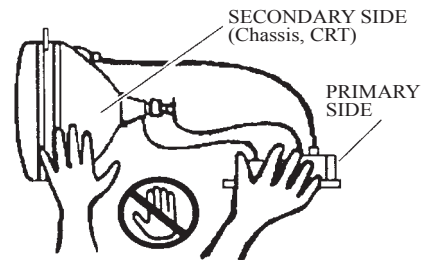

- Connecting the CRT and PCB
For combining the CRT and PCB, use the specified part No. to maintain the status of adjustments made at the factory. The anode of the CRT itself will be accumulatively charged as time elapses, generating high-tension voltage which is very dangerous. The monitor should be used with the Chassis, CRT and PCB assembled. When repair, etc. is required at the time of malfunctioning, be sure to send it in an "as is assembled" condition. If these are disassembled, what's charged to said high tension voltage can be discharged, causing a very hazardous situation. Therefore, under no circumstances should it be disassembled.



- Static Electricity
Touching the CRT surface sometimes causes you to slightly feel electricity. This is because the CRT surfaces are subject to static and will not adversely affect the human body.
- Installation and removal
Ensure that the Magnetizer Coil, FBT (Fly-Back Transformer), Anode Lead and Focus Lead are not positioned close to the sheet metal work's sharp edges, etc. and avoid damaging the insulated portions so as not to cause electric shock and malfunctioning. (For the name of parts, refer to the above Figures).



CAUTION

For the purpose of static prevention, special coating is applied to the CRT face of this product. To protect the coating, pay attention to the following points. Damaging the coating film can cause electric shock to the customers.

- Do not apply or rub with a hard item (a rod with pointed edge, pen, etc.) to or on the CRT surfaces.
- Avoid applying stickers, seals, etc. on the CRT face.
- Do not remove aluminum foils from the CRT corners. Removing the aluminum foils can cause static prevention effects to be lowered.

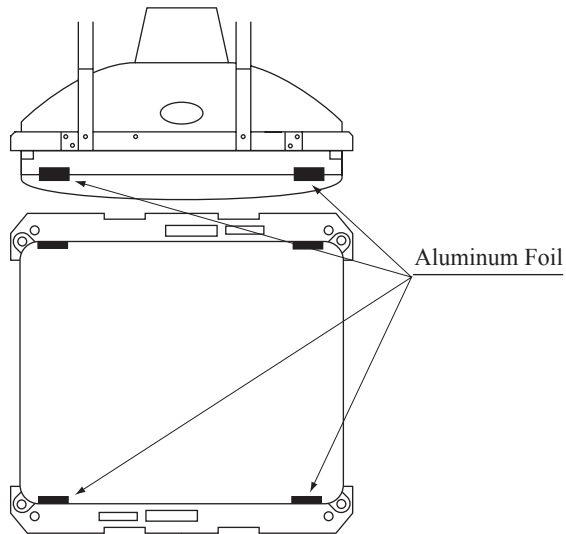

15-2 CLEANING THE CRT SURFACES



CAUTION

Static preventive coating is applied to the CRT surfaces. When cleaning, pay attention to the following points. Peeling off of static preventive coat can cause electric shock.

- Remove smears by using a dry, soft cloth (flannels, etc.). Do not use a coarse gauze, etc.
- For smear removing solvent, alcohol (ethanol) is recommended. When using chemical detergent, be sure to follow instructions below:
 - Dilute chemical detergent with water and dip a soft cloth in and then thoroughly wring it to wipe smears off.
 - Do not use a chemical detergent containing an abradant, powder or bleaching agent.
 - Do not use alkaline chemical detergents such as "glass cleaner" available on the market or solvents such as thinner, etc.
- Do not rub or scratch the CRT face with hard items such as brushes, scrub brush, etc.

Clean the CRT surfaces once a week. When cleaning, pay attention to the above caution so that the antistatic coating will not come off.

16. PERIODIC INSPECTION TABLE

The items listed below require periodic check and maintenance to retain the performance of this machine and to ensure safe business operation.

When handling the controller, the player will be in direct contact with it . In order to always allow the player to enjoy the game, be sure to clean it regularly. Also, it is advisable to provide wet tissue, etc. available for player use.



- Be sure to check once a year to see if Power Cords are damaged, the plug is securely inserted, dust is accumulated between the Socket Outlet and the Power Plug, etc. Using the product with dust as is accumulated can cause fire and electric shock hazards.
- Never use a water jet, etc. to clean inside and outside the cabinet. If wetness occurs for any reason, do not use the product until it has completely dried.
- Periodically once a year, request the place of contact herein stated or the Distributor, etc. where the product was purchased from, as regards the internal cleaning. Using the product with dust as is accumulated in the interior without cleaning can cause a fire or accident. Note that cleaning the interior parts can be performed on a pay-basis.

TABLE 16

ITEMS	DESCRIPTION	PERIOD
CABINET	Check Adjusters'contact with surface.	Daily
CONTOROL PANEL	Cleaning	As necessary
	Inspection of VR	Monthly
	Inspection of adjusting gear mesh	Trimonthly
	Greasing	Trimonthly
SHIFT LEVER	Inspection of SW	Monthly
	Greasing	Trimonthly
ACCEL. & BRAKE	Inspection of VR	Monthly
	Gear and Spring portion greasing	Trimonthly
MONITOR	SCREEN cleaning.	Weekly
	Check adjustments.	Monthly or when moving.
COIN CHUTE DOOR	Inspection of COIN SW	Monthly
	Coin insertion test	Monthly
	Cleaning of COIN SELECTOR.	Trimonthly
SEAT	Greasing to the seat rail	Trimonthly
GAME BD	MEMORY TEST	Monthly
	Check settings.	Monthly
POWER SUPPLY PLUG	Inspection and cleaning	Annually
INTERIOR	Cleaning	
CABINET SURFACES	Cleaning	As necessary

CLEANING THE CABINET SURFACES

When the cabinet surfaces are badly soiled, remove stains with a soft cloth dipped in water or diluted (with water) chemical detergent and squeezed dry. To avoid damaging surface finish, do not use such solvents as thinner, benzine, etc. other than ethyl alcohol, or abrasives, bleaching agent and chemical dustcloth.

SEAT (Greasing to Seat Rail Portion)

Move the Seat to the rearmost position and apply spray greasing to the portion shown at the right once every 3 months .

After greasing, move the Seat a few times forward and backward so as to allow the grease to be applied all over uniformly. Be sure to wipe grease which attaches to the surfaces of the PROTECT RUBBER on the Seat Rail, or any excess grease.

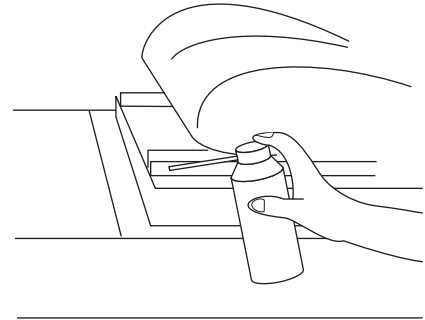

FIG. 16

17. GAME BOARD



- In order to prevent electric shock and short circuit hazards, be sure to turn power off before performing work.
- Be careful not to damage the wires. Damaged wires may cause electric shock or short circuit or present a fire risk.
- Do not expose the Game BD, etc. without a good reason. Failure to observe this can cause electric shock hazard or malfunctioning.
- Do not use this product with connectors other than those that were connected and used with the Game Board at the time of shipping. Do not carelessly connect wires to connectors that were not used at the time of shipping, as this may cause overheating, smoke or fire damage.



- In this product, setting changes are made during the test mode. The Game BD need not be operated. Use the Game BD, etc. as is with the same setting made at the time of shipment so as not to cause electric shock and malfunctioning.
- Static electricity from your body may damage some electronics devices on the IC board. Before handling the IC board, touch a grounded metallic surface so that the static electricity can be discharged.



When having the game board replaced or repaired, use the included carton box to ship it. Do not disassemble it. If the board is not received in the proper condition, it may not be eligible for repair or replacement, or extra service charges may be applied. The disassembly procedure for the game board is described in this manual for the purpose of replacing the battery inside the board. Do not disassemble the board when sending it in for replacement or repair.

17-1 REMOVING THE GD-ROM DRIVE

- Turn the power off.
- Open the game unit
- Remove the GD cable connector and the power cord connector from the GD-ROM drive.

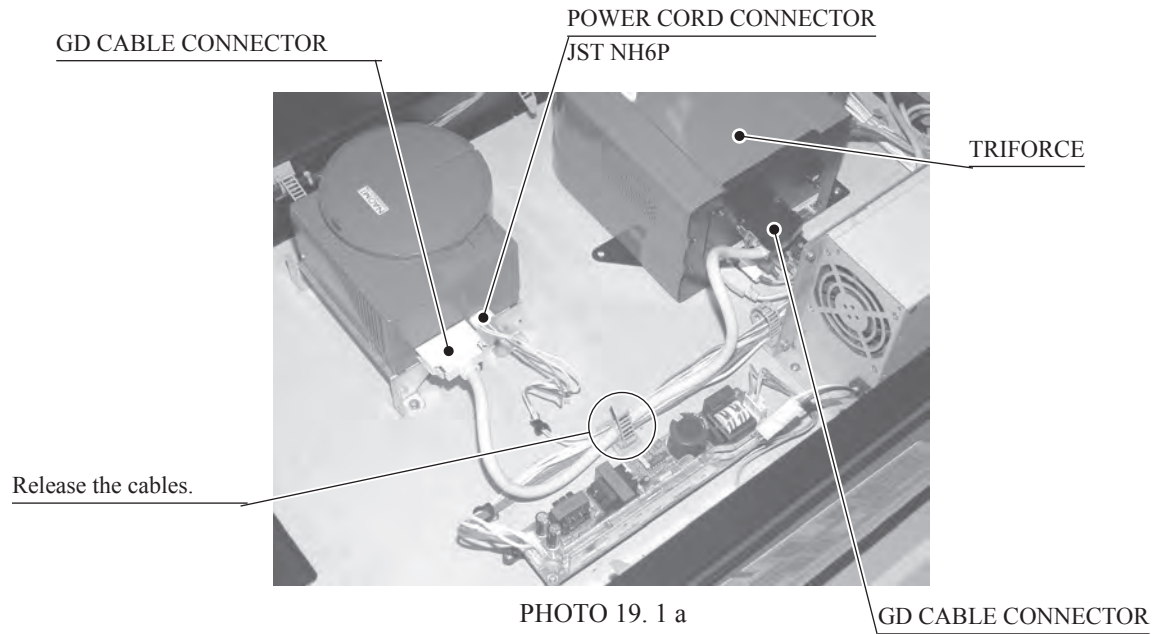

- Remove the 4 screws to remove the GD-ROM drive.

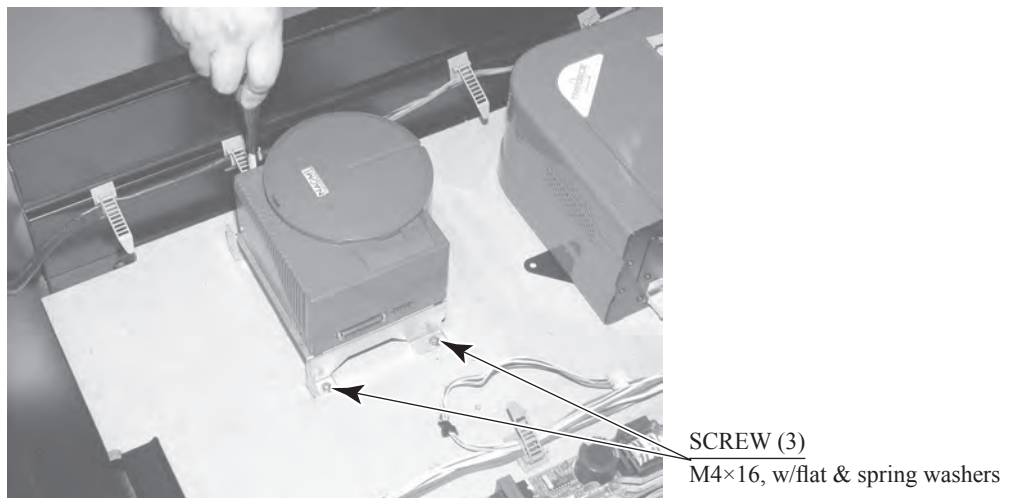

PHOTO 19.1 b

17-2 COMPOSITION OF THE GAME BOARD



IMPORTANT

Once the Chihiro Board has the Key Chip inserted, it is this product's specialized Game Board.

ASSY CASE BOX ORT

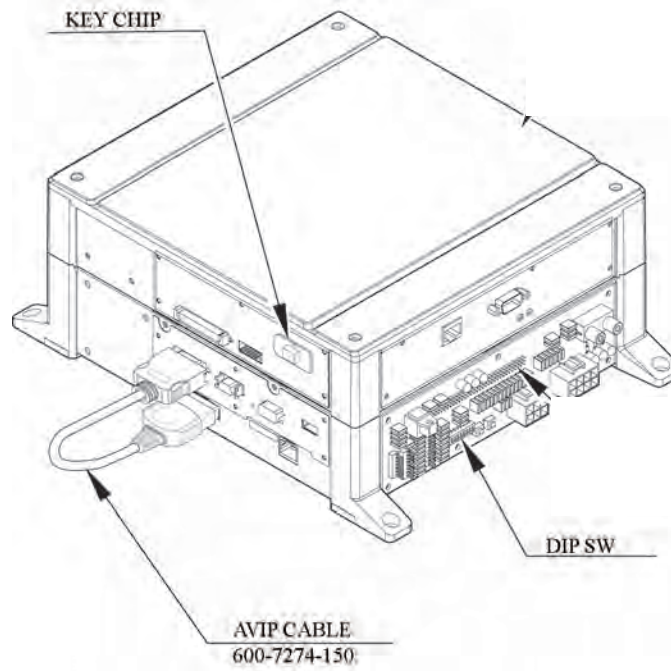

FIG. 17. 2 a

DIP SW SETTING

Use this product with the DIP SW settings shown in the figure below.

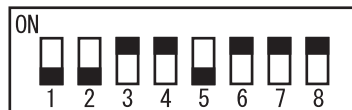

FIG. 17. 2 b

17-3 REPLACING THE MAIN BOARD BATTERY



- To prevent overheating, explosion, or fire:
 - Do not recharge, disassemble, heat, incinerate, or short the battery.
 - Do not allow the battery to come into direct contact with metallic objects or other batteries.
 - To preserve the battery, wrap it in tape or other insulating material.
- Follow local regulations when disposing of the battery. Improper disposal can damage the environment.



- To avoid risk of malfunction and damage:
- Make sure the positive and negative ends are aligned correctly.
 - Use only batteries approved for use with this unit.



If an error appears indicating that the battery power is very low within the first year of use, it is usually an indication of a problem or abnormality with something other than the battery. Be sure to inspect the board that the battery is connected to.

- There is a Media Board Button Battery underneath the Media Board.

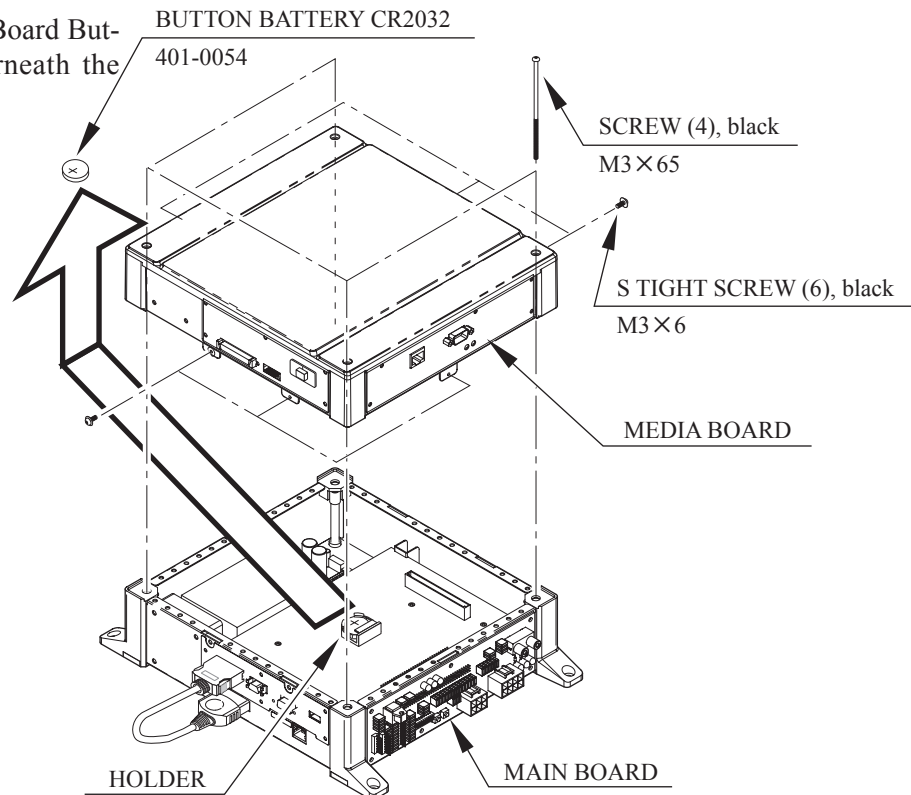

FIG. 16. 3

- Carefully remove the battery from its holder.
- Insert a new battery into the holder with the "+" terminal facing up.

Prohibitions and Cautions to Handle the Battery Pack

Be careful when handling the battery pack.

We bear no responsibility for problems caused by handling clearly contrary to the content of this manual.



- Do not disassemble the battery pack and the batteries.
If you should fail to observe this instruction, the internal wires and/or protective devices may be damaged; as a result the safety system may not function when discharging and recharging, eventually causing an overheating, fire and explosion. If you should disassemble the batteries, the generated gases may harm your throat and the negative plate may overheat and make a fire.
- Do not make an external short circuit of the battery pack and the batteries.
If you should fail to observe this instruction, the batteries may overheat, make a fire, and explode.
- Do not fire the battery pack and the batteries.
If you should fail to observe this instruction, the batteries may make a fire and explode.
Do not leave the battery pack and the batteries nearby the heat source (fire or heater) or under the intense direct sunlight and flaming sun. If you should fail to observe this instruction, the batteries may reduce the service life and in the worst case may overheat, make a fire, and explode.
- Do not leave the battery pack and the batteries in water or seawater. Also do not apply water or seawater onto the battery pack and the batteries. If you should fail to observe this instruction, the internal wires and/or protective devices may be damaged; as a result the safety system may not function when discharging and recharging, eventually causing an overheating, fire and explosion. Also water may be electrolyzed into oxygen and hydrogen, and eventually the battery's sealed section may be corroded and the internal liquid may leak.
- Do not solder on the battery pack's terminals.
If you should fail to observe this instruction, the armor may be heated and melted or the internal wires may be damaged, eventually causing an overheating, fire and explosion. Also, when the battery's temperature reaches to 100° or more, the battery may leak its internal liquid due to destruction of its plastic parts (gasket, separator, etc.), or may overheat, make a fire, or explode due to internal short-circuit.
- Do not insert or connect the battery in a reversal polarity.
If you should fail to observe this instruction, the battery may be externally short-circuited and eventually overheat, make a fire, or explode, depending on the device you connect with.



- Do not tightly seal the battery pack when installing it onto an external device. Flammable gas is generated from the battery when its safety mechanism has functioned. If you should fail to observe the above-described instruction, sparks from motors, switches, etc. may cause the gas to fire. Therefore, install the battery pack so that the gas can be quickly released from the external device.
- Do not use the battery pack for the device/usage other than this game system. If you should fail to observe this instruction, the battery and/or the device may be damaged due to non-applicable specifications.
- Do not strike a nail in, hammer, step on, or apply any other forms of pressures and shocks on, the battery.
If you should fail to observe this instruction, the battery may be deformed. As a result, the battery may burst at its sealed sections to leak the internal liquid, or may be short-circuited internally to overheat, make a fire, and explode.
- Do not use a battery charger because any battery charger is not usable for this battery pack.
If you should fail to observe this instruction, the gas may be suddenly generated in the battery and eventually the battery may overheat, make a fire or explode.
- If the battery in use or in keeping shows an abnormal indication (deformation, change of color, bursting of the armor cover, etc.), immediately stop using or keeping it. If it leaks and smells abnormally, immediately keep it away from fire and put it in a safety box.
- If the liquid leaks from the battery and gets in your eyes, do not rub your eyes but immediately wash them with clean water (city water etc.); and consult a medical doctor for a treatment. If you should fail to observe this instruction, the liquid may harm your eyes.
- The battery pack armor (a polyvinyl chloride tube) may be damaged or deformed by external force or heat. When transporting the battery pack or replacing it with a new one, therefore, be careful not to drop or excessively shock it. Do not continue to use any damaged or deformed battery pack. If you should fail to observe this instruction, the battery may overheat, make a fire, or explode.
- The battery pack contains a printed circuit board (PCB) for protective circuitry. It may be destroyed by the static electricity. When handling or servicing the battery pack, therefore, take preventive measures against the static electricity.
If your battery pack has shown destruction of a protective circuitry PCB, do not continue to use it. If you should fail to observe this instruction, the battery may overheat, make a fire, or explode.
- When wiring the battery pack to a device, be careful not to apply excessive force onto the connectors and lead wires. The battery may overheat, make a fire, or explode if the connectors and lead wires are damaged.
- Do not do away with the used battery packs carelessly because they may contaminate the environment. Be sure to dispose of the used battery packs in accordance with the laws/regulations of your country.

If the GD-ROM read time becomes excessively long, it is likely that the Media Board battery pack life is running low.
No battery pack charger is available.
Follow the procedure to replace the battery pack.

- Remove 4 screws from the upper face of the board.
- Remove the top cover.
- Remove 1 tapping screw and remove the cover battery holder.
- Disconnect the connector at the end of the wire coming out of the battery pack. Remove by pressing the projection on the connector and pulling.
- Securely connect the new battery pack.
- Attach the cover battery holder and top cover.

Submit the used battery packs to an industrial waste disposal plant. Thus they must be disposed according to the local laws and the regulations in your country.

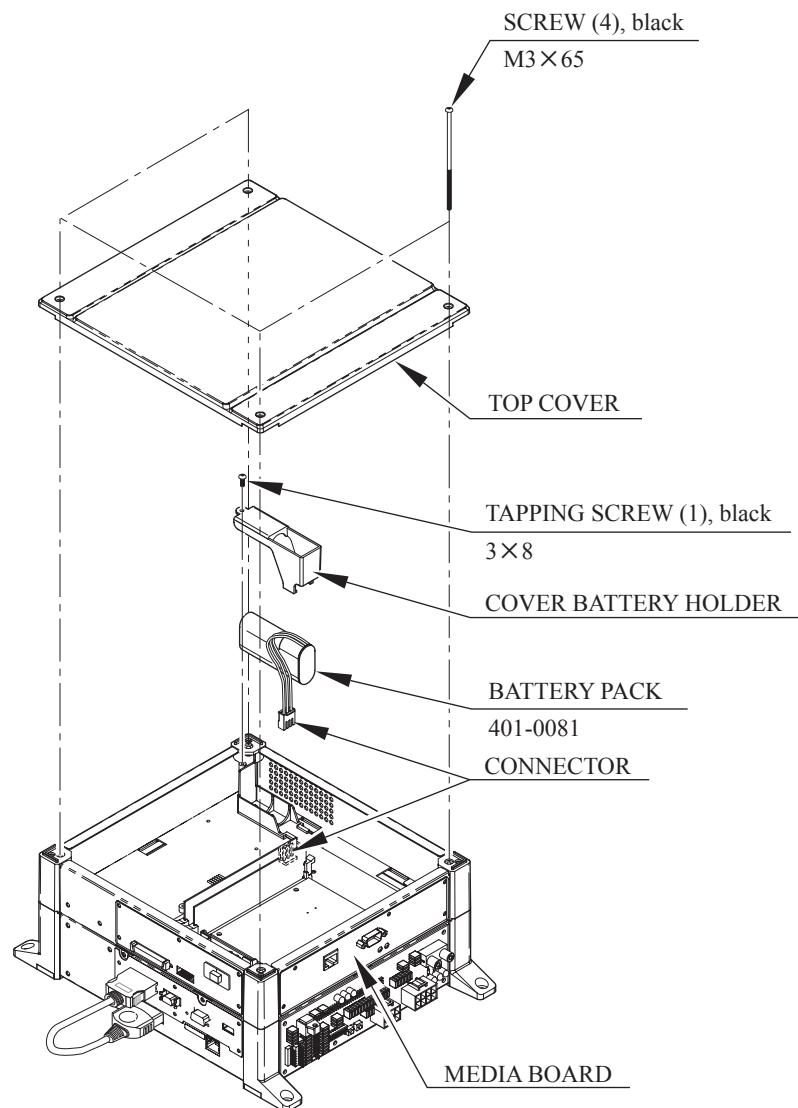

FIG. 16. 4

18. NETWORK PLAY

Up to 4 machines can be linked for network play. Properly connected network cables and correct network play settings are required for network play.

18-1 PRECAUTIONS REGARDING NETWORK PLAY SETUP



- Before starting to work, ensure that the Power SW is OFF. Failure to observe this can cause electric shock or short circuit.
- Use care so as not to damage wirings. Damaged wiring can cause electric shock or short circuit.
- Do not touch undesignated places. Touching places not designated can cause electric shock or short circuit.
- This work should be performed by the site maintenance individual or other skilled professional. Performing work by non-technical personnel can cause electric shock hazard.
- When linking a number of machines, be sure to supply sufficient power for the corresponding number of machines. Be sure to secure per machine current as stated in this manual. Failure to observe this can cause a fire and an electric shock accident.
- Due to the length of the network cable, the distance in between the machines is limited. However, to avoid accidents, be sure to secure space in excess of 70 cm between the machines.
- To perform work safely and avoid serious accident such as the cabinet's falling down, do not perform work in places where step-like grade differences, a ditch, or slope exist.



- To perform work safely, be sure to secure the space corresponding to number of machines to be linked. Failure to observe this can cause accident.
- To avoid accidents, use a cable cover that will not cause patrons to trip when laying network cables in areas of heavy foot traffic.
- To prevent accidents and acts of vandalism, cover the network cables with the strongest cover possible.



Network play is not possible between game machines with different cabinet types.

When connecting several games machines together, make sure that a sufficient amount of electrical power is available for each machine. Plan on providing 7A for each machine in 100-120V locations, and 4A in 220-240V locations.

SPACING OF GAME MACHINES

Be sure to secure space in excess of the described distance between machines.

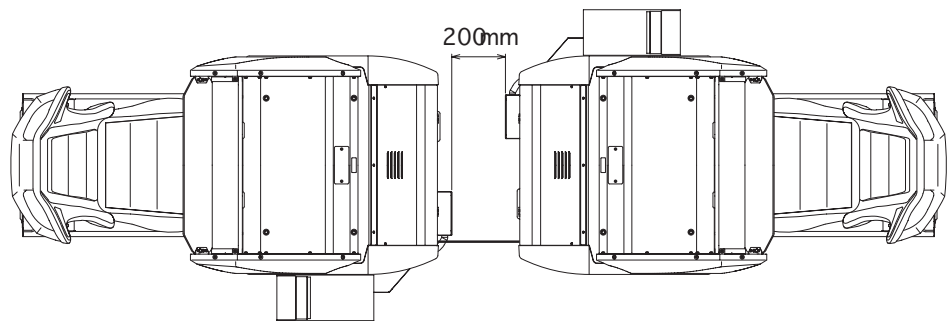
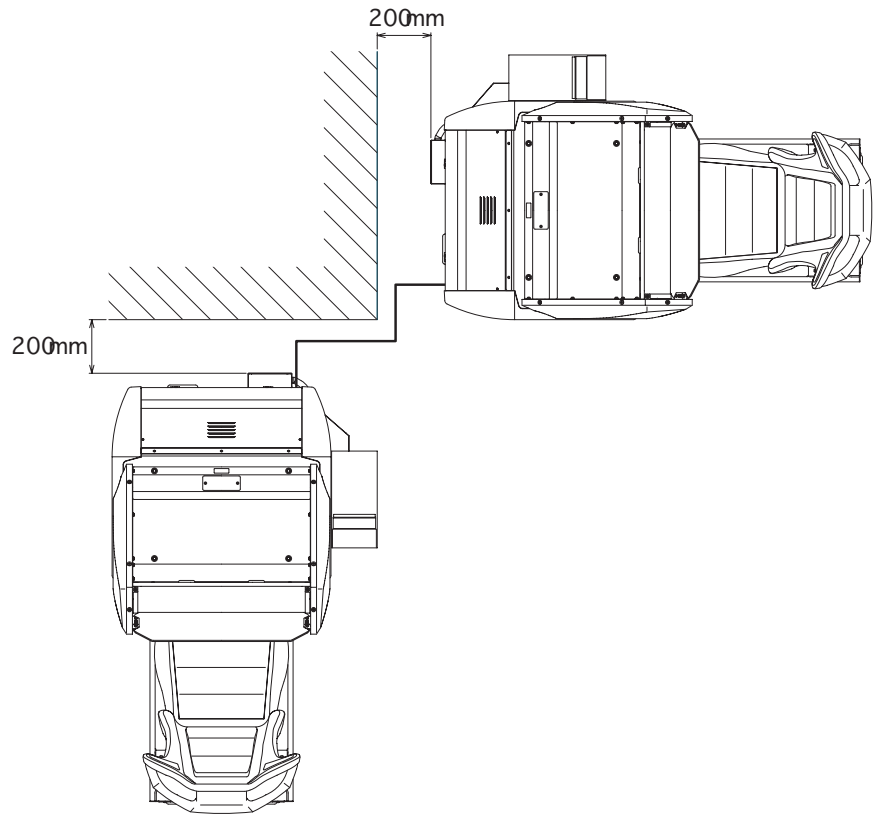
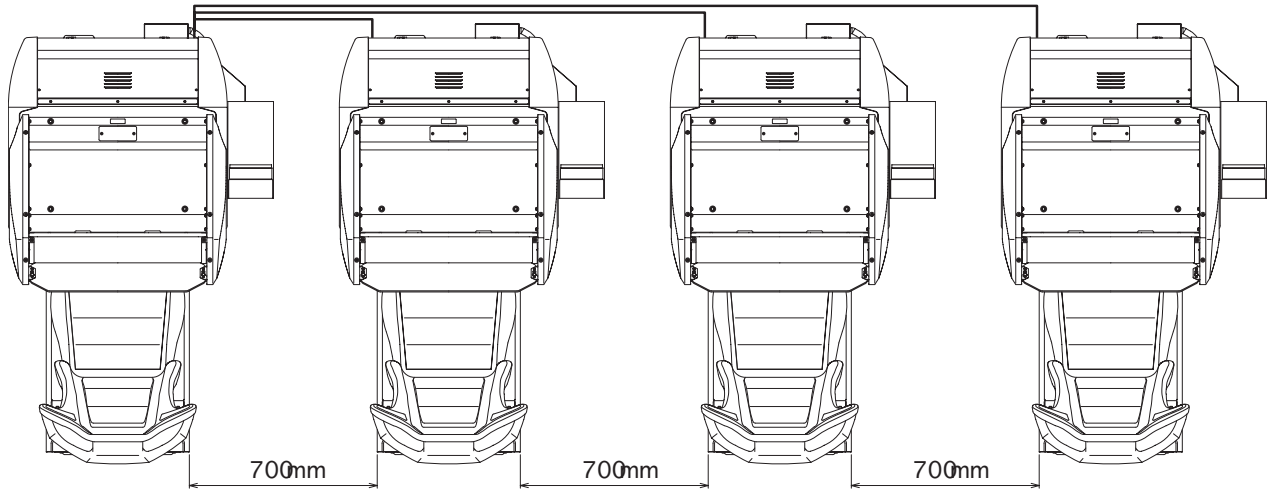

FIG. 18. 1

18-2 CONNECTING NETWORK CABLES

To enable network play, the hubs inside each of the game machines involved must be connected with network (LAN) cables. Connect the hub inside one of the machines to the hubs in each of the other machines using LAN cables. There is no need to connect the other machines to each other.

Do not connect LAN cables to game machines when they are not used for network play.

- Turn off the power and unplug the power cord from the outlet. Place the power cord so as not to damage it while working.
- Move the machines so that they are lined up. Leave enough space on the back lid side of the machine to perform the rest of the operations in this procedure.
- Pass the LAN cable through the edge holder (the rectangular frame-shaped plastic part.) Pressing down on the edge holder from above will cause it to stretch elastically and open up.
- Plug the connector on the end of the LAN cable into port 2 or above on the hub. Port 1, located at the front closest to the front lid, is connected to the CHIRIHO in the base interior.
Any of the ports 2 or above can be used to connect to any of the other game machines.
Since the hub in one machine will be connected to the hubs in each of the other machines via LAN cables, only one machine needs to be fitted with enough LAN cables for all machines involved. The other machines will only have 2 cable connections each.
- Once the machines have been linked for network play, line them up. Leave as much space as possible between the machines.
- Connect the power cord and grounding wire for each machine.

19. DESIGN RELATED PARTS



20. PARTS LIST



ITEM NO.	PART NO.	DESCRIPTION	NOTE
1	999-1961	Marquee Glass	3/16" x 28.969" x 9.813"
2	Local Purchase	Fluorescent bulb 24" F20T12CW	"Coolwhite"
3	999-0167	Leg Leveler 1/2-13 3"	
4	999-0168	Caster 160-2 1/2 Swivel	
5	999-2081	Seat	
6	999-2111	Speaker 4" 6oz. 8Ohm 25W	
7	Local Purchase	Monitor Glass	3/16" x 28.875" x 22.688"
8	999-2110	Monitor Bezel	
9	610-0408-91	Shifter Up/Down	
10	INY-1204	Cover Shifter Indy 500	
11	DYN-1223X	Cover Shift B	
12	999-1596	Fan 110/120 VAC 17/15W Sinwan	
13	SPG-2200	Accel and Brake Assy.	
14	999-2010	Vent Air 4 Hole	
15	DYN-1209X	Handle Collar	
16	999-2114	Steering Wheel Bezel	
17	999-1604	Vent Air 8 Hole	
18	ORTT-00242	Slide Seat Assy w/ Modified Handle	
19	999-2118	Pushbutton Rect. VLT Blue View	
20	999-1861	PSH BTTN SM VLT YEL RND Start	
21	SPG-2001	Steering Wheel	

Parts Not Indicated List

ITEM NO.	PART NO.	DESCRIPTION	NOTE
1	999-1899	Meter Coin 6VDC (6)digit w/diode	
2	999-1860	Knob 1/4" Shaft 450-2023	
3	601-11351	SW Hub Melco LSW10/100-8H	
4	998-1222	Pot 5K Ohm	
5	998-0676	Switch On/Off Rocker	
6	999-2114	Steering Wheel Bezel	
7	999-1177	Cash Box	
8	600-7141-100	Cable JVS Type A-B 100CM	
9	600-7247-500	Cable SCSI ST-L Type2 500MM	
10	600-7269-0200	Assy Lan Cable 200CM	
11	999-0574	Plate Leg Leveler	
12	999-2119	Monitor Glass Retainer Bracket	
13	999-2120	Rubber Mat Cabinet	
14	999-2121	Rubber Seat Base Mat	
15	999-2122	Rubber Seat Step Mat	

ASSY ACCEL&BRAKE (SPG-2200)

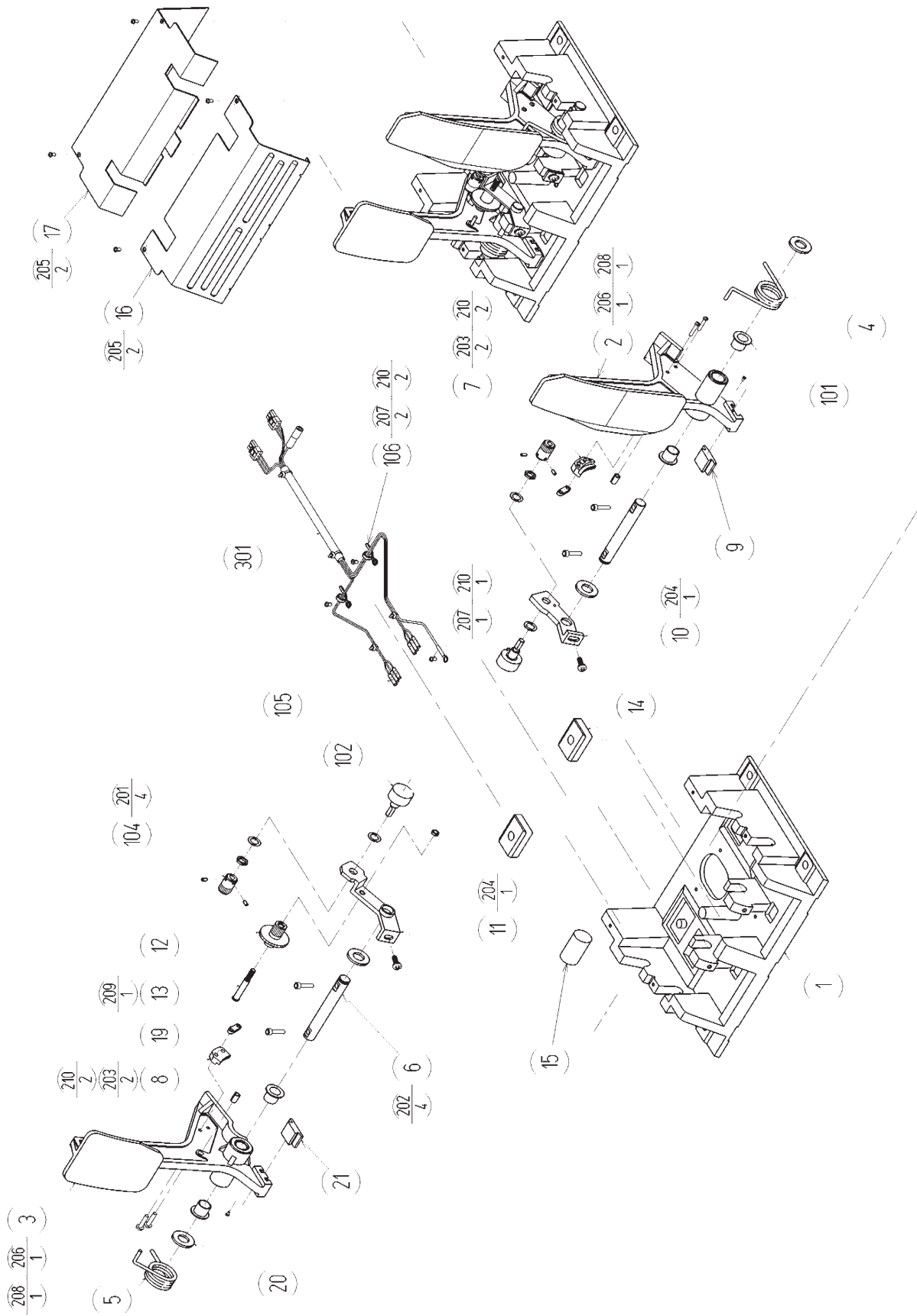

ASSY ACCEL&BRAKE (SPG-2200)

ITEM NO.	PART NO.	DESCRIPTION	NOTE
1	SPG-2201	BASE	
2	SPG-2202	ACCEL PEDAL	
3	SPG-2203	BRAKE PEDAL	
4	SPG-2204	ACCEL SPRING	
5	SPG-2205	BRAKE SPRING	
6	SPG-2206	SHAFT	
7	SPG-2207	ACCEL GEAR	
8	SPG-2208	BRAKE GEAR	
9	SPG-2209	NEUTRAL STOPPER	
10	SPG-2210	VR PLATE ACCEL	
11	SPG-2211	VR PLATE BRAKE	
12	SPG-2212	AMPL GEAR	
13	SPG-2213	GEAR SHAFT	
14	SPG-2214	STOPPER	
15	SPG-2215	RUBBER CUSHION	
16	SPG-2216	COVER	
17	SPG-2217	VR COVER	
19	SPG-2219	GEAR STAY	
20	SPG-2220	WSHR	
21	SPG-2221	NEUTRAL STOPPER D	
101	100-5263	BEARING 12(OILES 80F-1212)	
102	220-5484	VOL CONT B-5K OHM	
104	601-7944	GEAR 15	
105	310-5029-F15	SUMITUBE F F15MM	
106	280-0419	HARNES LUG	
201	028-A00304-P	SET SCR HEX SKT CUP P M3×4	
202	020-000520-0Z	HEX SKT H CAP SCR BLK M5×20	
203	000-P00420	M SCR PH M4×20	
204	000-P00508-W	M SCR PH W/FS M5×8	
205	000-T00408-0C	M SCR TH CRM M4×8	
206	FAS-450005	SPR PIN BLK OZ 6×10	
207	000-P00405	M SCR PH M4×5	
208	FAS-000001	M SCR TH CRM M3×6	
209	050-H00500	HEX NUT M5	
210	060-F00400	FLT WSHR M4	

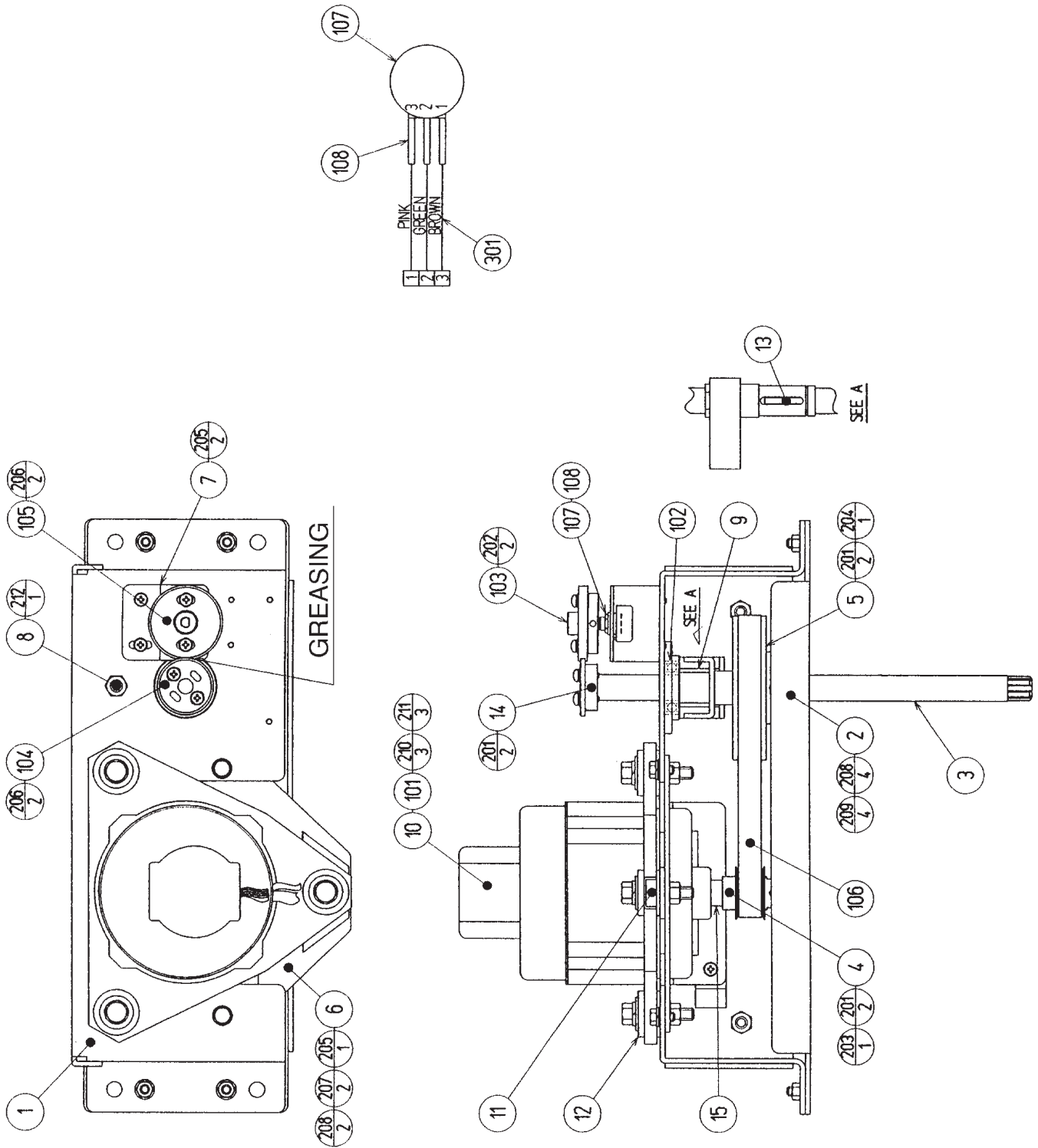

ASSY HANDLE MECHA (SPG-2500)

D-2/2

ITEM NO.	PART NO.	DESCRIPTION	NOTE
1	SPG-2501	HANDLE BASE	
2	SPG-2502	BASE LID	
3	SPG-2503	HANDLE SHAFT	
4	SPG-2504	PULLEY 20 S5M	
5	SPG-2505	PULLEY 60 S5M	
6	SPG-2506	MOTOR BRKT	
7	SPG-2507	VR BRKT	
8	SPG-2108	STOPPER BOLT	
9	SPG-2109	STOPPER RUBBER	
10	SPG-2453	KEY 4×4×40	
11	ASK-3502	MOTOR SPACER	
12	ASK-3503	MOTOR COLLAR	
13	DYN-1270	STOPPER KEY	
14	SLC-1130	ADJUST RING	
15	SPG-2454	MOTOR SHAFT COLLAR	
101	350-5448-01	SERVO MOTOR 500W NEW	
102	100-5112	BEARING 17	
103	601-8966	GEAR HOLDER	
104	601-6172	GEAR 48	
105	601-6959	GEAR 64	
106	601-9173	TIMING BELT	
107	220-5484	VOL CONT B-5K OHM	
	220-5373	VOL CONT B-5K	
108	310-5029-F20	SUMITUBE F F 20MM	
201	028-A00408-P	SET SCR HEX SKT CUP P M4×8	
202	028-A00308-P	SET SCR HEX SKT CUP P M3×8	
203	065-S012S0-Z	STP RING BLK OZ S12	
204	065-S020S0-Z	STP RING BLK OZ S20	
205	000-P00408-W	M SCR PH W/FS M4×8	
206	000-P00412-W	M SCR PH W/FS M4×12	
207	030-000612-S	HEX BLT W/S M6×12	
208	060-F00600	FLT WSHR M6	
209	050-U00600	U NUT M6	
210	030-000840-S	HEX BLT W/S M8×40	
211	068-852216	FLT WSHR 8.5-22 ×1.6	
212	050-U00800	U NUT M8	
301	600-6866	WIRE HARN ASSY HANDLE MECHA VR	

ELECTRONICS LOWER

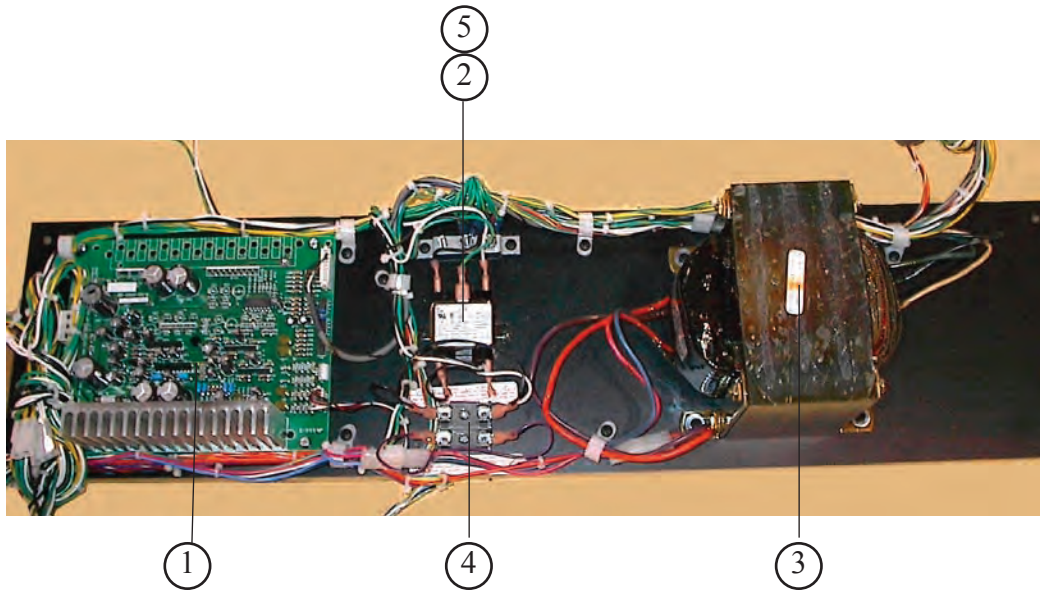

ITEM NO.	PART NO.	DESCRIPTION	NOTE
1	838-13578	Audio Power Amp 2ch. and Mixer	
2	Local Purchase	3A Slow Blow Fuse	
3	998-0138	Isolation Transformer ER-503	
4	998-0218	Line Filter	
5	Local Purchase	5A Slow Blow Fuse	

ELECTRONICS UPPER

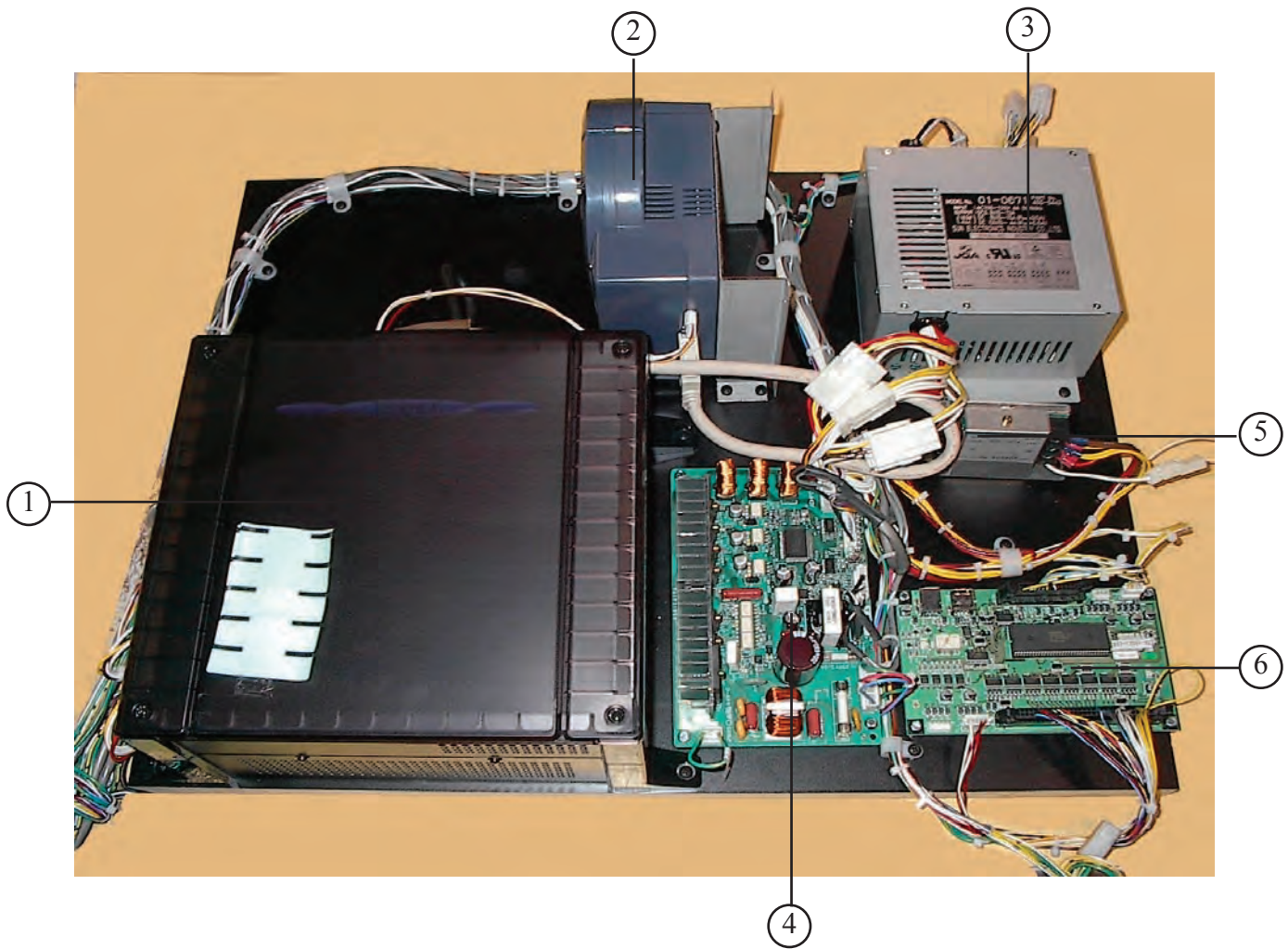

ITEM NO.	PART NO.	DESCRIPTION	NOTE
1	843-0005D-01	Assy Case Box ORT USA	
2	XKT-0833	Kit GDRom drive w/ Label	
3	400-5443	Power Supply	
4	838-14174	Servo Motor Drive BD.	Only first 50 Units
5	610-0674	Power Protetor Unit for Chihiro	
6	837-13551-92	I/O Control BD for JVS	

21. WIRE COLOR CODE TABLE

THE WIRE COLOR CODE is as follow:

- A PINK
- B SKY BLUE
- C BROWN
- D PURPLE
- E LIGHT GREEN

Wires other than those of any of the above 5 single colors will be displayed by 2 alphanumeric characters.

- 1 RED
- 2 BLUE
- 3 YELLOW
- 4 GREEN
- 5 WHITE
- 7 ORANGE
- 8 BLACK
- 9 GRAY

If the right-hand side numeral of the code is 0, then the wire will be of a single color shown by the left-hand side numeral (see the above).

Note 1: If the right-hand side alphanumeric is not 0, that particular wire has a spiral color code. The left-hand side character shows the base color and the right-hand side one, the spiral color.

<Example> 51 WHITE / RED

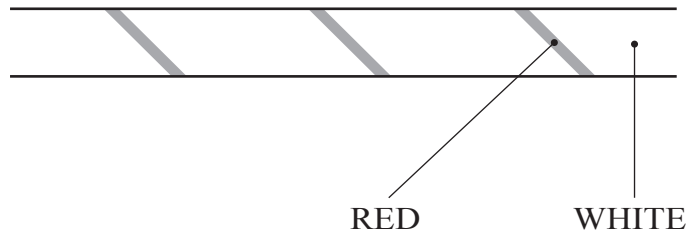

Note 2: The character following the wire color code indicates the size of the wire.

- U: AWG16
- K: AWG18
- L: AWG20
- None: AWG22

Warranty

Your new Sega Product is covered for a period of 90 days from the date of shipment. This certifies that the Printed Circuit Boards, Power Supplies and Monitor are to be free of defects in workmanship or materials under normal operating conditions. This also certifies that all Interactive Control Assemblies are to be free from defects in workmanship and materials under normal operating conditions. No other product in this machine is hereby covered.

Sellers sole liability in the event a warranted part described above fails shall be, at its option, to replace or repair the defective part during the warranty period. For Warranty claims, contact your Sega Distributor.

Should the Seller determine, by inspection that the product was caused by Accident, Misuse, Neglect, Alteration, Improper Repair, Installation or Testing, the warranty offered will be null and void.

Under no circumstances is the Seller responsible for any loss of profits, loss of use, or other damages.

This shall be the exclusive written Warranty of the original purchaser expressed in lieu of all other warranties expressed or implied. Under no circumstance shall it extend beyond the period of time listed above.



SEGA AMUSEMENTS USA, INC.

45133 Industrial Drive
Fremont, CA 94538
(415) 701-6580 phone
(415) 701-6594 fax