

AMERICAN LASER GAMES™

OPERATION & SERVICE MANUAL FOR ALL GAMES

VERSION 1.04

24 April 1993

AMERICAN LASER GAMES
4801 LINCOLN ROAD N.E.
ALBUQUERQUE, NM 87109
(505) 880-1718

For Technical Service and Support

contact

Dan Montano

TABLE OF CONTENTS

PAGE

1	Table of Contents
2	Warranty
3	Initial Inspection & Installation
4	Description of Major Components of the Game
6	Component and Connector Locations in Equipment Tray drawing
7	Laser Disk Player/Main Computer Board connections & System Interconnect diagram
8	Console Switch cable and Gun Wiring diagrams
9	AC Power and Audio/Coin-Light wiring diagrams
10	Main Computer Board/RAM-ROM and TAOS (opto/amplifier) layout/connector diagrams
11	LDP serial, computer board power, bill acceptor, & console wiring cable diagrams
12	TAOS board description and comparison to separate optoisolator & audio boards
	<u>TAOS board schematics and Game Wiring diagrams</u>
13	Audio amplifier
14	12 volt power supply and ticket machine interface (Rev. 1.2)
15	Isolated power supply and console switch optoisolation
16	Gun optoisolation/selection circuitry
17	Low voltage harness: coin/audio transformer & lights, console switches
18	Low voltage harness: remote volume control, speakers, ticket machine
19	TAOS board interconnect diagram
20	AC wiring: AC input, fuse & switch, marquee, monitor isolation transformer., auxiliary monitor power, AC outlet, wall-plug transformer
21	GROUND wiring
22	TAOS board component locator (Rev. 1.2)
23	TAOS board bill of materials (Rev. 1.2)
25	Monitor & white source board, adjustment procedure (25" games with Hantarex monitors only)
26	Gun shot board - Component layout & bill of materials
27	Gun shot board - Schematic
28	Optoisolator board - Component layout & bill of materials (pre-TAOS board)
29	Optoisolator board - Schematic
30	Audio amplifier board - Schematic
31	Troubleshooting guide
	Service screens with explanations and <i>helpful information</i>
35Crime Patrol
41Mad Dog II - The Lost Gold - 1 and 2 player
47Mad Dog McCree
52Space Pirates and Who Shot Johnny Rock
56Gallagher's Gallery

ICAT, INC./AMERICAN LASER GAMES

STATEMENT OF LIMITED WARRANTY

ICAT, Inc./American Laser Games warrants that the System will be in good working order for the duration of the Warranty Period. The Warranty Period shall begin on the date of receipt of shipment by customer and shall last for thirty (30) days. However, no warranty shall extend beyond ninety (90) days after the date of shipment from ICAT, Inc./American Laser Games.

If any portion of the System fails to be in good working order during the Warranty Period, and if ICAT, Inc./American Laser Games is notified within this time, ICAT, Inc./American Laser Games shall have the option of repairing or replacing the failing portion of the System. Service parts and replacement products, if any, will be furnished on an exchange basis. Customer shall pay for all shipping charges and any duties and taxes for parts returned to ICAT, Inc./American Laser Games. ICAT, Inc./American Laser Games will pay for shipping charges for the repaired or replaced material. All replaced parts and products become the property of ICAT, Inc./American Laser Games. Parts & products which have been tampered with are excluded from any warranty.

ALL CLAIMS FOR WARRANTY MUST BE ACCOMPANIED BY PROOF OF PURCHASE, SERIAL NUMBER OF THE FAILED ITEM, AND THE CORRESPONDING GAME SERIAL NUMBER.

The Warranties under this Agreement are in lieu of any conflicting statement of Limited Warranty included with a product shipment, except for products that are subject to Federal or State consumer warranty laws. For such products, any statement of limited warranty included with a product shipment applies.

ICAT, Inc./American Laser Games does not warrant that the operation of the System or Software will be uninterrupted or error-free.

The foregoing Warranties are in lieu of all other warranties, express, statutory, or implied, including, but not limited to, the implied warranties of merchantability and fitness for a particular purpose.

INSTALLATION

INITIAL INSPECTION

This American Laser Game has been thoroughly tested and burned in at the factory. No special setup procedures should be required. However it is suggested that upon receiving the game you check the following to insure proper game operation.

Inspect the game for any damage which may have occurred in shipment. Report damage to carrier.

All connectors are firmly seated.

All components on printed circuit boards are firmly seated, particularly the RAM/ROM board inside the grey metal EMI box located just above the Laser Disk Player (see the Equipment Tray Component Locations diagram). The RAM/ROM board may be packaged separately with the game manuals. Also check that the wall-plug transformer has remained plugged into the internal AC outlet on the wiring board located on the right rear side of the cabinet.

All fuses are installed firmly.

All protective shipping materials have been removed.

No loose screws, wires, etc.. which may cause electrical shorting or mechanical binding.

Unit is free of moisture...particularly the laser disk player. If player is cold, let reach room temperature before operating or damage may result due to moisture (see LDP manual).

Coin mechanism (plus bill & ticket dispenser mechanisms, if applicable) are operating properly.

GAME INSTALLATION

For 33" and 50" games, follow the assembly instructions which are taped to the front glass.

The following precautions should be taken when installing the game.

Handle the laser disk with care so as not to scratch it.

Do NOT install the game in excessively humid or dusty environments.

Do NOT install the game near a heat source or in direct sunlight. Doing so may cause the game's internal temperature to exceed its maximum temperature and result in damage to the game. On games which have a fan, clean the filter periodically to prevent filter clogging.

Insure that the game's power source is properly grounded to the power service entrance.

When installing the game take adequate protection against static electricity.

CAUTION

FOR SAFE OPERATION OF THIS GAME IT IS STRONGLY RECOMMENDED THAT THE CABINET BE PROPERLY GROUNDED. THIS GAME IS EQUIPPED WITH A THREE PRONGED POWER PLUG. THE ROUND PRONG ON THIS POWER PLUG WILL AUTOMATICALLY GROUND THE GAME WHEN PLUGGED INTO A PROPERLY GROUNDED THREE PRONG RECEPTACLE. IF IT IS NECESSARY TO USE A TWO PRONG ADAPTER, THE GROUNDING LUG OR WIRE ON THE ADAPTER MUST BE PROPERLY GROUNDED.

DESCRIPTION OF MAJOR COMPONENTS OF THE GAME

A **laser disk player (LDP) and disk** which together provide video imagery for the game. The laser disk player video is combined with computer generated video from the main computer board. The LDP requires periodic maintenance (cleaning & alignment) and the disk should be cleaned weekly.

A **main computer board** which generates credit, scoring, bullets, and gunshot video plus gunshot audio. It also commands the laserdisk player (through an RS-232 link) to various scenes depending upon the game-player's actions. The main computer board keeps track of game activity including coin accounting, games played, and game times. It also provides for adjustment of the **cost to start** the game, to **continue** a game, and how often the audio is heard during **attract mode**. It allows you to **calibrate the gun aiming** and run a variety of **hardware tests**. The main computer board also **interfaces** to the guns and the L/R START, L/R COIN, and SERVICE switches via the TAOS (optoisolator/audio amplifier) board. It also controls an (optional) **ticket dispenser**.

The main computer board has it's own **power supply**. This power supply has its own power switch which if turned off will prevent any video from being displayed (black screen) and coins will NOT be recognized.

A **RAM/ROM board** which plugs onto the main computer board via a card edge connector. It contains software for the game as well as information about when & where targets may be hit. It also contains **battery-backed RAM memory** which saves **game setups, coin information, and gun calibration values**...even when main AC power is interrupted.

A **genlock unit** which provides for overlay/mixing of the computer generated video with the laser disk video. It is attached to the main computer board at CN-9 via a D-style connector through which it receives the computer generated analog RGB video. It receives laser disk NTSC video through a RCA-style connector and outputs combined NTSC composite video through another RCA-style connector to a monitor or TV (see the equipment connector diagram).

Game playing guns. The **guns detect light** from the monitor after the player pulls a gun trigger. The main computer board determines (via data in the RAM/ROM board memory) whether the player has hit or missed the target. Gun calibration should be performed during game setup or if a gun isn't shooting where it's aimed, if a gun is replaced, or if the RAM/ROM card or EPROMs are replaced. (see *Service Screens* at the back of this manual for details on gun calibration) Early guns (those with a surface mount 4011 IC on the gun shot board inside the gun) require the use of a **shot amp module** in-line with the gun cable. Newer guns (those with an LM311 IC on the gun shot board) will not work properly if a shot amp module is installed.

Note that early Mad Dog McCree games had a separate **yellow wire** in the game wire harness for **gun RELOAD**. On newer games, the **RELOAD** signal comes through pin 1 of the gun 9-pin 'D' connector. Many guns have a yellow wire coming out of the **gun** 9-pin 'D' connector backshell. This yellow wire is included for compatibility with early game harnesses and is not needed on newer games.

Color video monitor or TV. The monitor or TV is sent **NTSC video** from the genlock. This video is the combined video from the laser disk player and the main computer board. The **video is combined in the genlock** which is attached to the main computer board. The main computer board drives the screen a bright white for a single video frame each time a gun trigger is pulled. The **gun detects this flash** and the main computer board determines where the gun is pointed.

The 50" TVs have a parental lock-out feature which has a 4-digit access code. If this becomes activated accidentally and you don't know the access code, simultaneously press the **QUICKVIEW** and **2** keys on the remote control. This will temporarily unlock (until power is turned off) the TV. See the TV instruction book for details on how to change the code permanently.

An **isolation transformer** is used on 25" and 33" ALG games to provide isolated 120 VAC 60Hz power to the monitor. All AC power flows through a **5-amp slow-blow fuse**.

TAOS (optoisolator/amplifier) board. (Replaces separate optoisolator and audio amplifier boards) The TAOS board, together with isolated power provided by a **plug-in wall transformer**, provides **electrical isolation and electrostatic discharge (ESD) protection** for the console switches and the guns. The TAOS board provides **gun multiplexing** which is necessary for 2-gun operation. The TAOS board provides an **optional ticket dispenser** with a MOTOR START signal and +12VDC & GROUND derived from the AUDIO/COIN-LIGHT transformer. The TAOS board receives a ticket NOTCH SENSE signal and a TICKETS LOW signal from the ticket dispenser unit. **The ticket dispenser connects at J105. The ticket dispenser requires software version 2.0 or higher to work.**

The TAOS board also provides **audio amplification** for the laser disk player and computer outputs. Audio amp power is derived from the AUDIO/COIN-LIGHT transformer. RCA-style inputs are provided for left and right audio signals from the laser disk player and the computer board. **Jumper (JP3)** on the TAOS board straps the left & right ~~computer~~ audio together so **only one computer audio cable is needed**. Both computer audio channels are driven and either computer audio output may be used, but it is best if only one is used because there is a slight phase shift between channels. Two pots (**R7 and R8**) on the TAOS board provide **adjustable balance** between the computer audio and the laser disk player audio. The TAOS board connects at J104 to a pair of **speakers** mounted in the game cabinet. The TAOS board is plug-compatible with the separate opto & audio-amp boards so replacement is easy.

A **remote volume potentiometer** is mounted near the SERVICE switch and connected to the TAOS board at J106 to provide overall loudness adjustment. It affects both laser player and computer audio. The remote volume control must be present...no audio will be heard without it.

Console switches. These consist of the left and right COIN ACCEPTOR switches, the left and right START switches, and the SERVICE switch. A bill acceptor may connect to the RT COIN input. These switches are read by the main computer board through the TAOS (optoisolator/amplifier) board.

Ticket Dispenser (optional) The ticket dispenser provides for operator-adjustable ticket dispensing. Multiple thresholds (based on the player's score) provide for awarding a ticket every XXXX points ... where XXXX is also adjustable by the operator. The ticket dispenser is controlled by the main computer board and driven through the TAOS (optoisolator/amplifier) board. A "**low tickets**" LED indicator is provided on the ticket dispenser door and an **audible alarm** sounds when the game runs completely out of tickets. A "**call manager**" message is then displayed followed by a "**tickets owed**" message. Also, a **feed tickets** function is provided to help with loading new tickets. The ticket bin is designed for **fan-fold tickets** and the dispenser mechanism **requires tickets with a hole punched at each ticket perforation**.

A **ventilation/cooling fan with dust filter** is provided on 25" ALG games. The fan and filter are located on the rear of the cabinet. The filter is important to prevent wear or failure of the laser disk player. **The filter should be cleaned periodically to ensure sufficient airflow for cooling.** Remove the filter metal cover, rinse the filter in water, let it dry, and replace the filter and the metal cover.

COMPONENT & CONNECTOR LOCATIONS IN EQUIPMENT TRAY

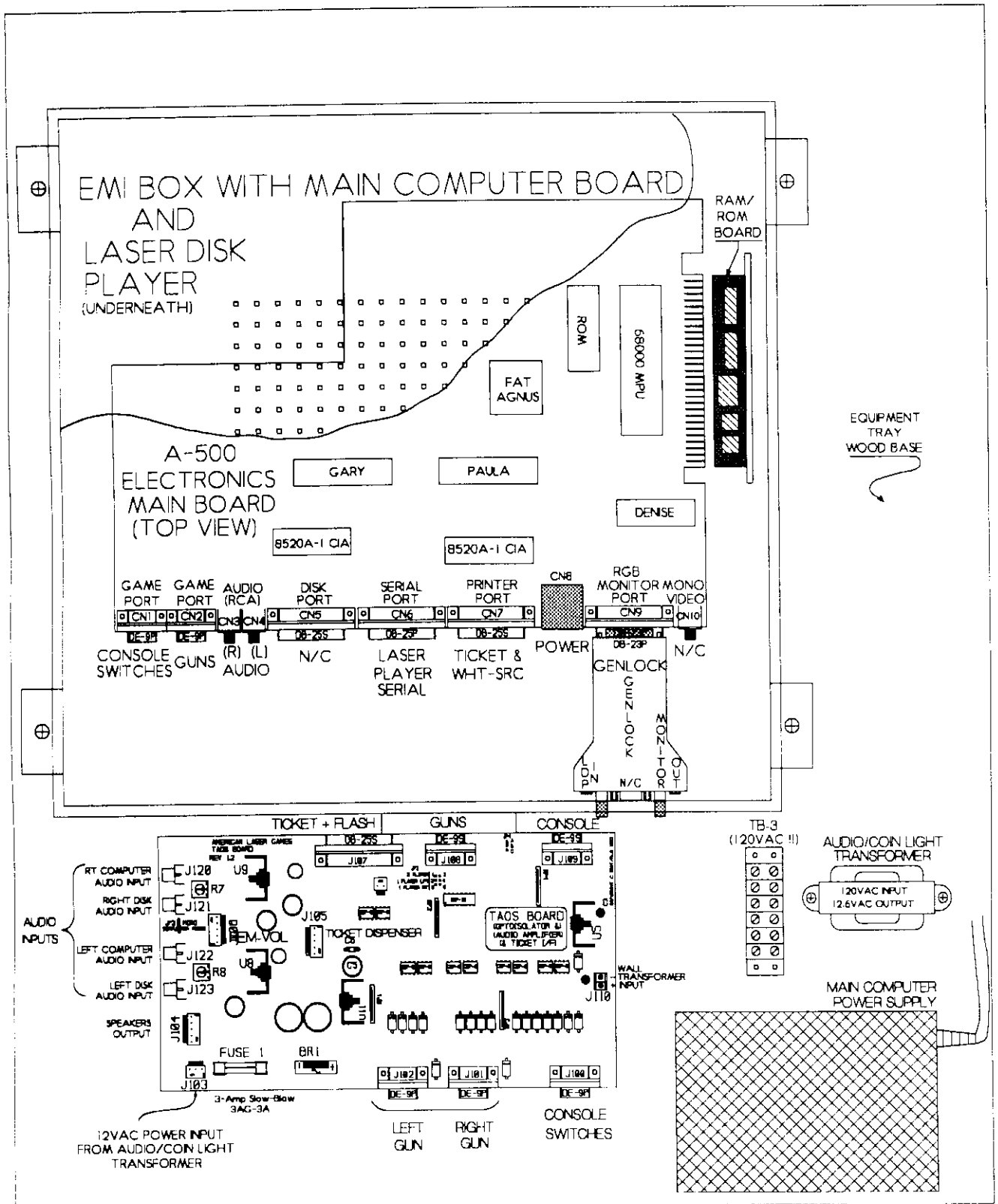

AMERICAN LASER GAMES

EQUIPMENT CONNECTOR LOCATIONS

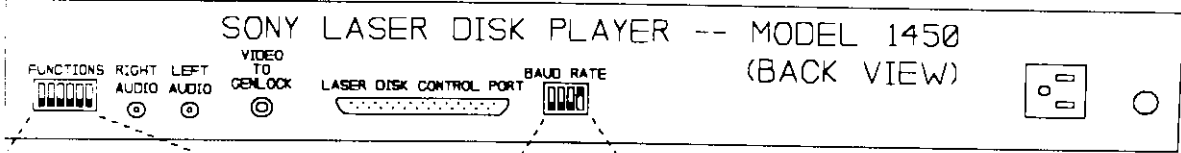
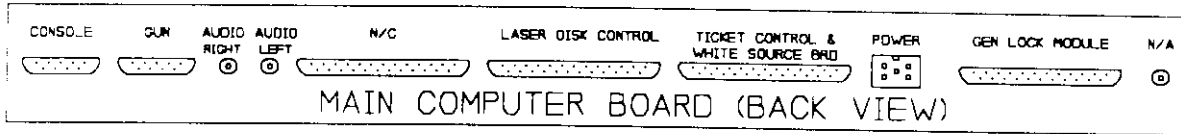
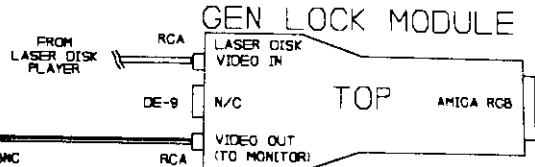

LASER DISK PLAYER FUNCTION SWITCH SETUP

LASER DISK PLAYER BAUD RATE SWITCH SETUP

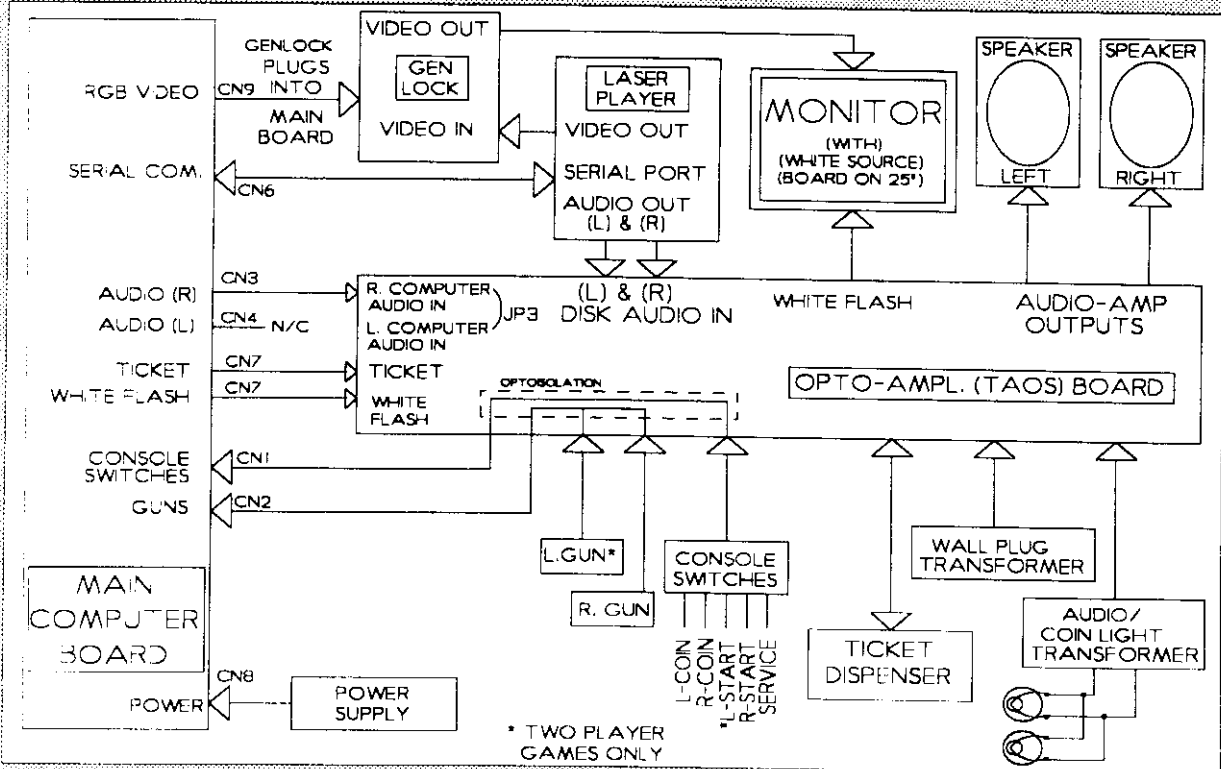

AMERICAN LASER GAMES

Console Switch Cable

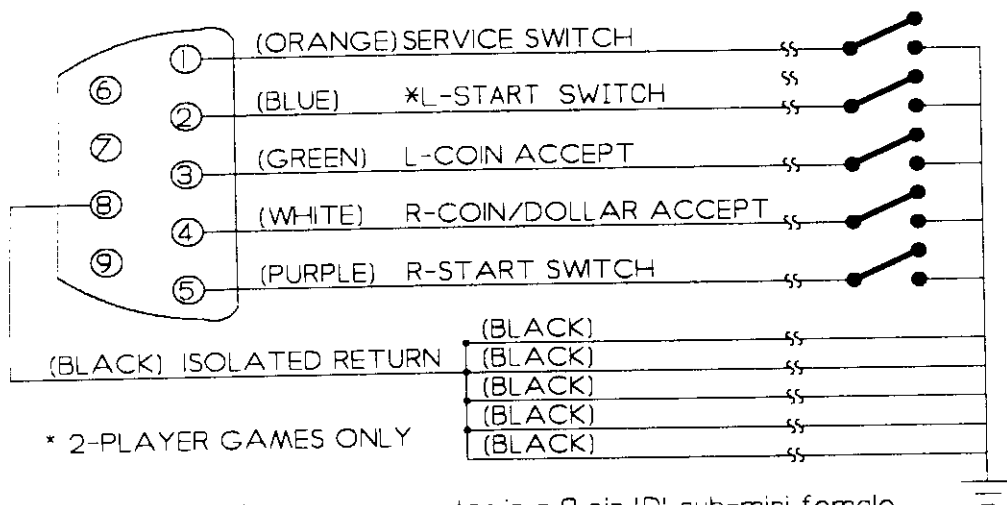

The cabinet harness connector is a 9 pin 'D' sub-mini female
The rear view (wiring side) of the connector is shown

GUN WIRING DIAGRAM

5-SHOT BOARD (IN GUN)

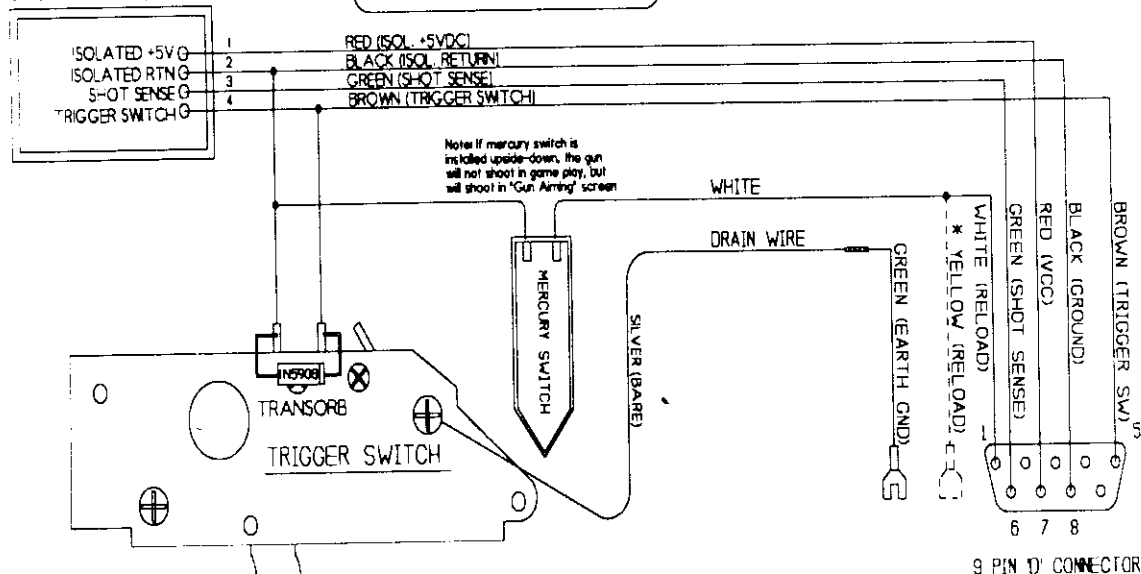

Space Pirates uses a Mouser-style gun.
Mad Dog McCree, Who Shot Johnny Rock, and
Galagher's Gallery use a 6-shooter style gun

Note: Mercury switch is only needed on
Mad Dog McCree game for RELOAD.
However, all guns, except Space Pirates guns,
have this mercury switch.

* YELLOW WIRE WAS NEEDED ONLY ON
VERY OLD GAMES.

ADD YELLOW WIRE (AS SHOWN) IF NEEDED
-OR- CONNECT HARNESS YELLOW WIRE
TO PIN 1 OF HARNESS 'D' CONNECTOR.

AMERICAN LASER GAMES

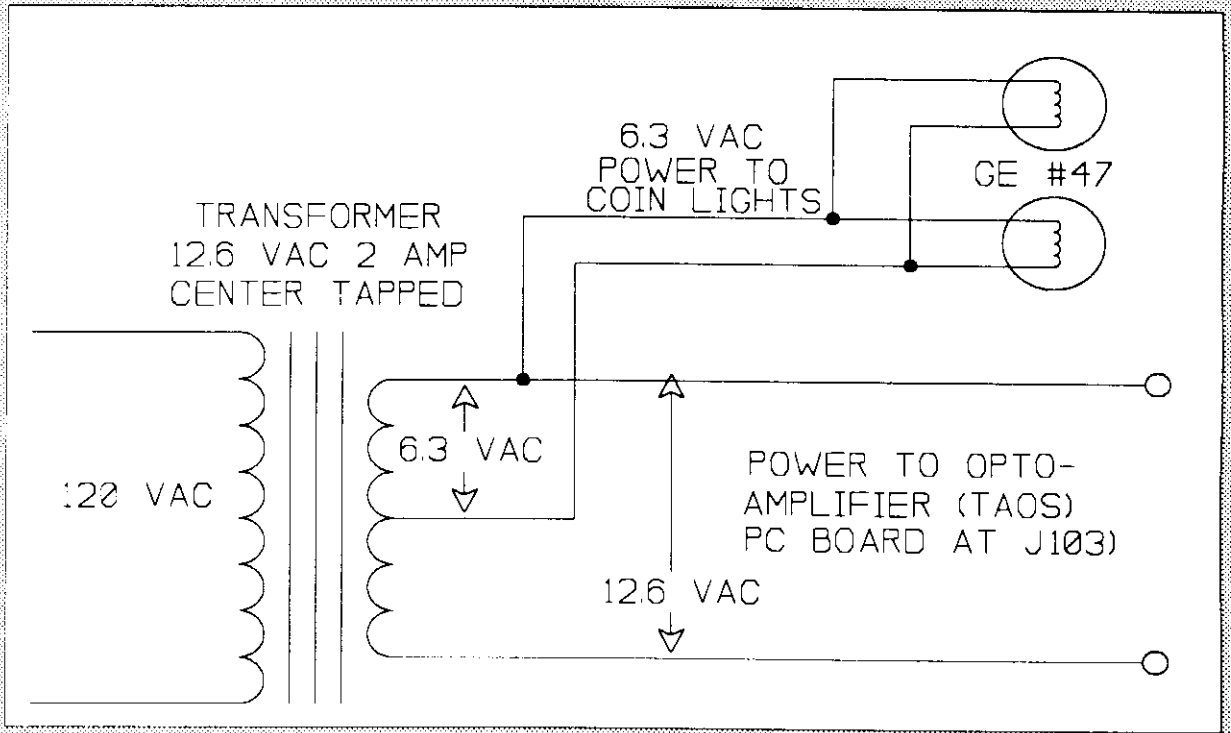
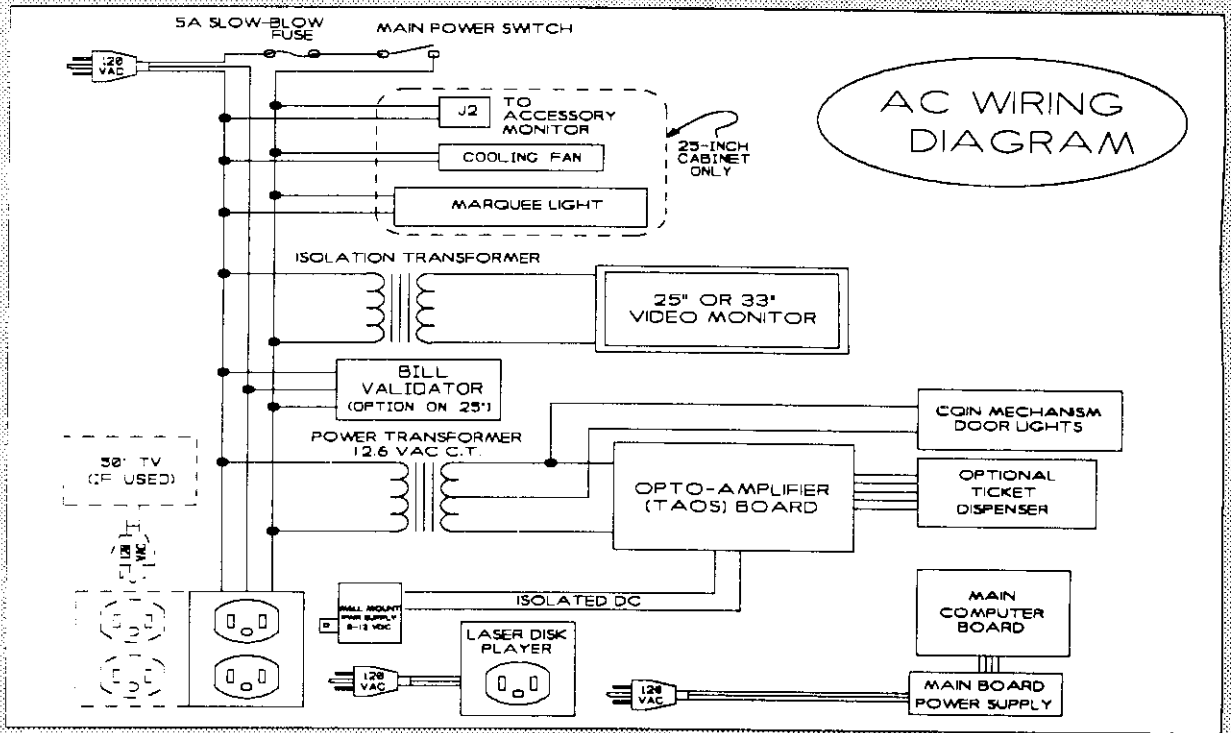

AMERICAN LASER GAMES

A-500 ELECTRONICS MAIN BOARD (TOP VIEW)

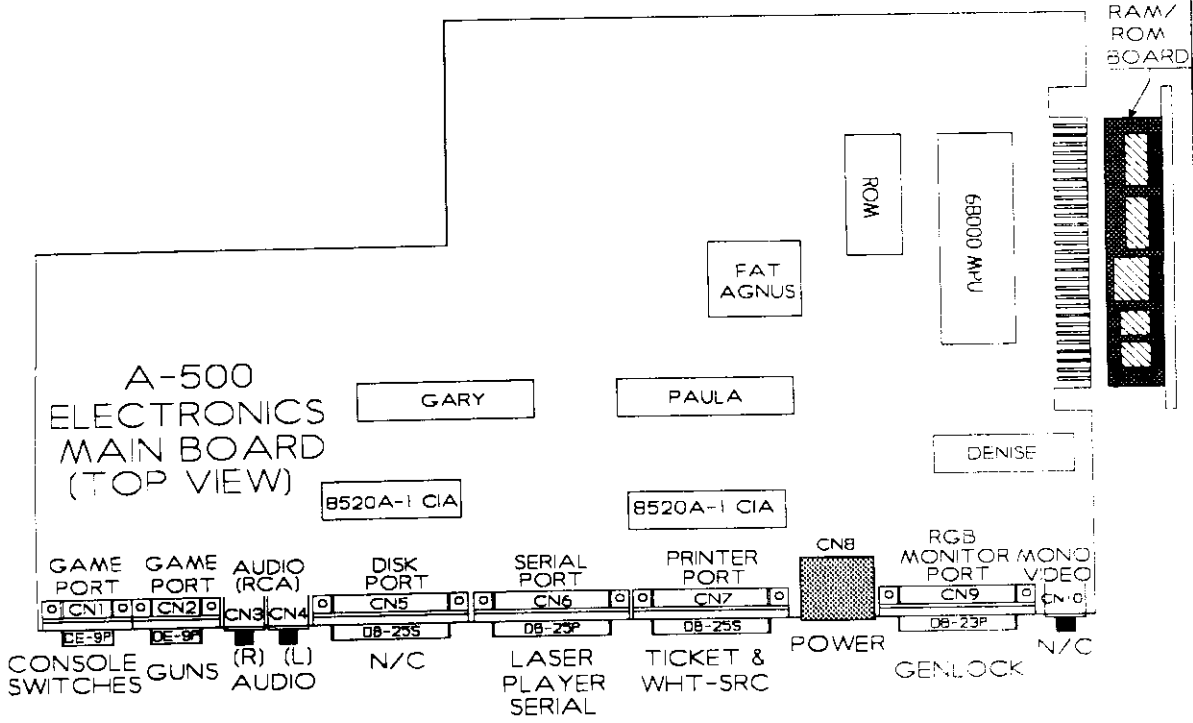

AMERICAN LASER GAMES TAOS BOARD REV 1.2

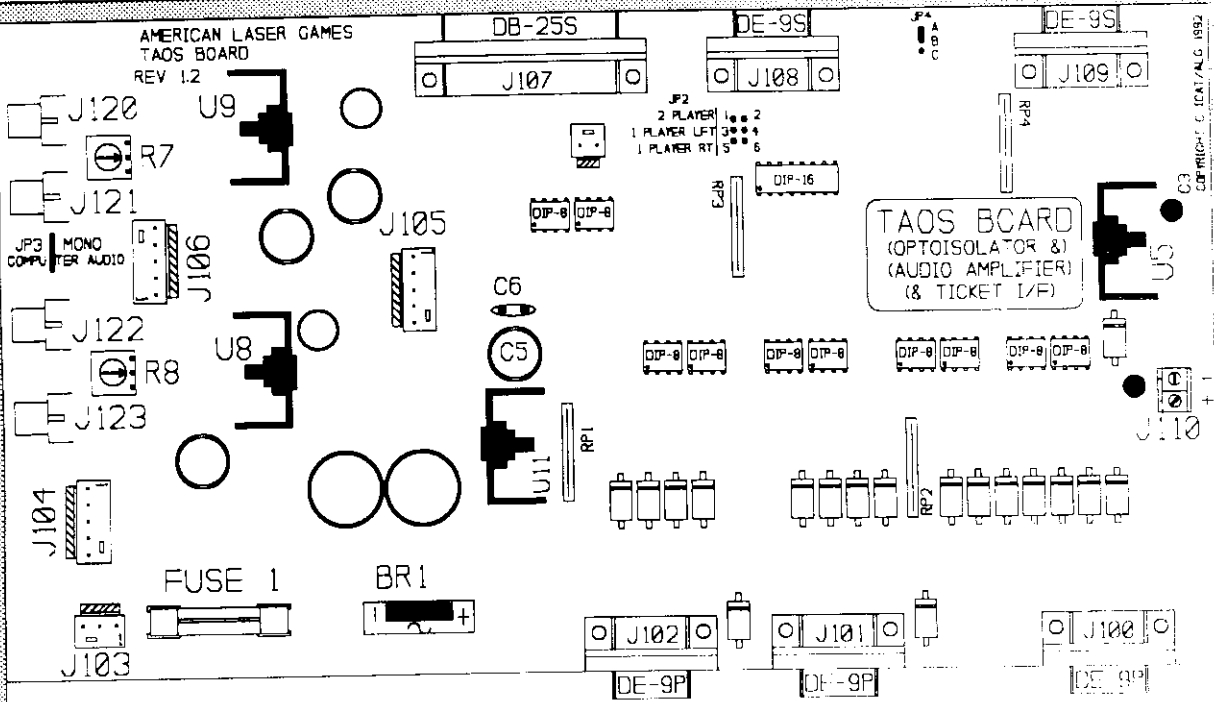

TAOS BOARD (Rev. 1.2) Optoisol/Audio Amplification

AMERICAN LASER GAMES

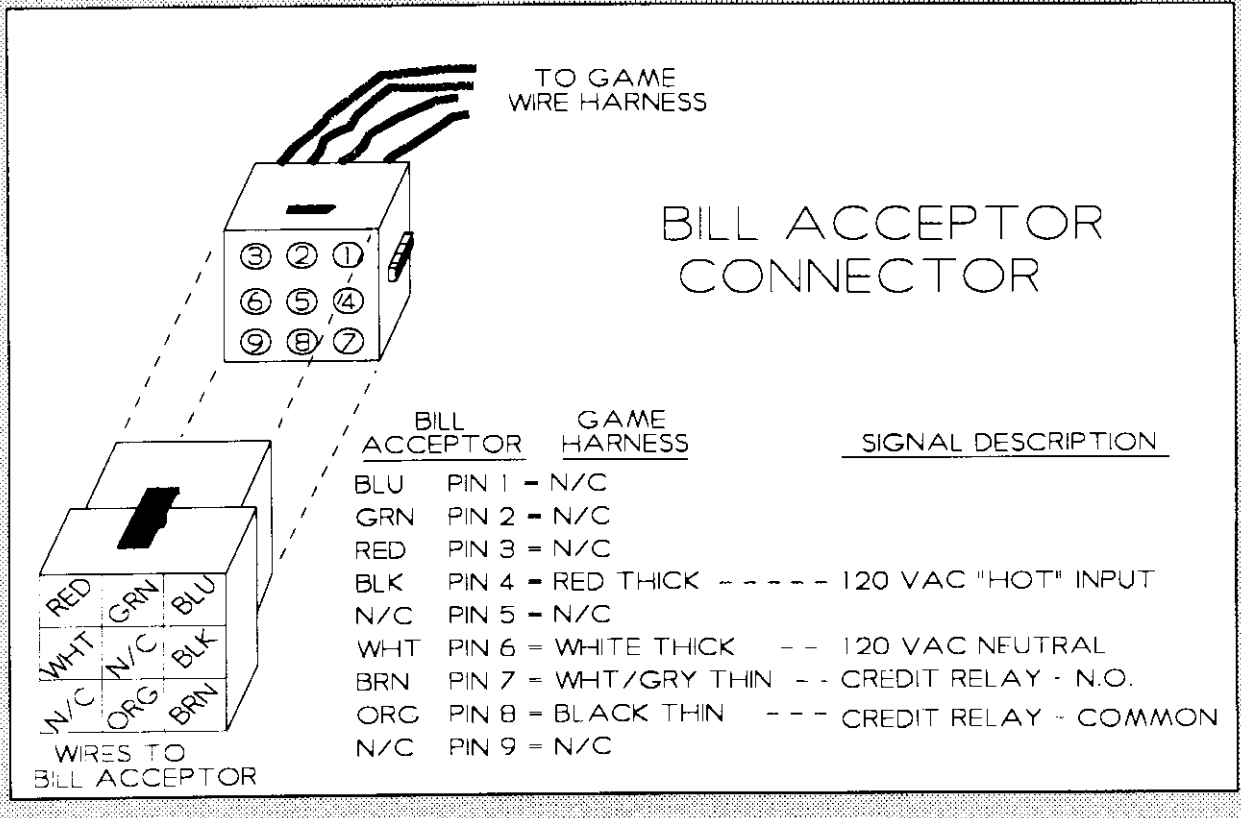
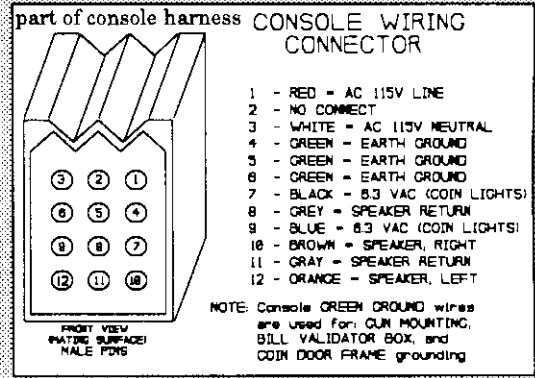
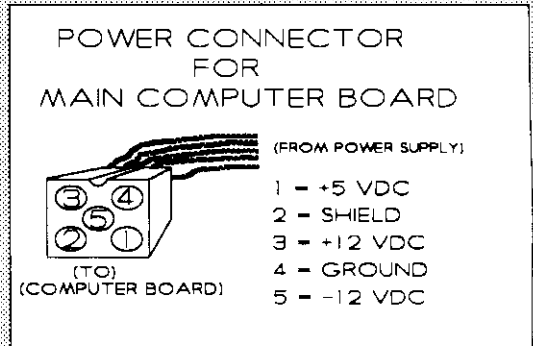
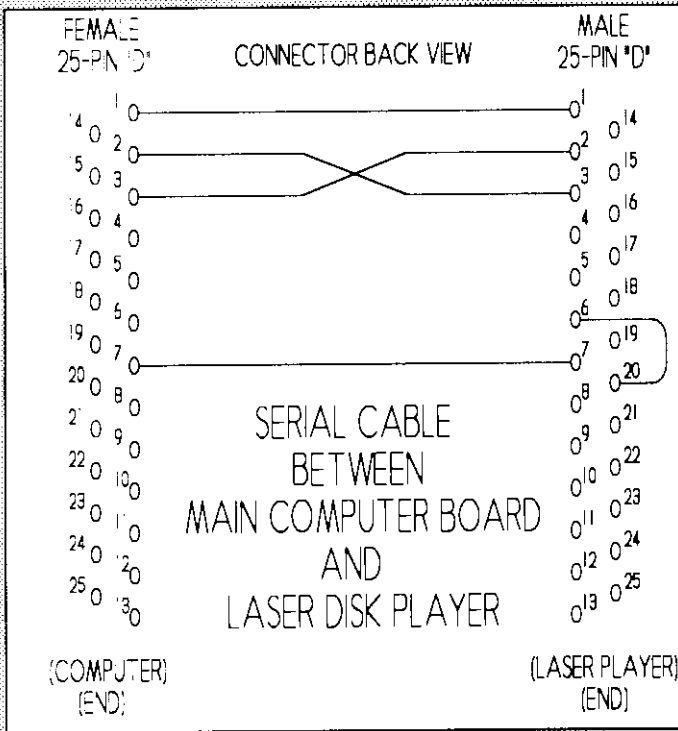

AMERICAN LASER GAMES

TAOS Opto-isolator/Audio-Amplifier Board

The separate Audio Amplifier and Optoisolator boards have been replaced by a single board which combines these two functions. The new board is referred to as the TAOS board. It is designed to directly replace the separate boards.

The TAOS board provides the same opto-isolation & ESD protection provided by the separate optoisolator board. The TAOS board uses the same power & connectors as the old opto board.

The TAOS board may be directly substituted for the separate Audio Amplifier and Optoisolator boards. The TAOS board receives 12.6 VAC power at J103 from the Audio/Coin-Light transformer...just like the old Audio Amplifier board. The TAOS board, like the old optoisolator board, receives isolated DC power from a plug-in wall transformer. **The TAOS board power connectors are the same as on the separate boards.**

There are two minor differences when using the TAOS board. The first is that **only one audio input cable from the main computer board is required** because the TAOS board provides a jumper (JP3) to strap the left & right channels together. The second difference is that **the TAOS board provides a connector (J106) for a remotely-mounted potentiometer to adjust overall audio volume.** (See the TAOS board schematic for wiring details). The remote volume control is a standard audio-taper dual pot with a full-scale value between 10K and 100K ohms (the full-scale value is non-critical).

The TAOS board accepts audio inputs from the Laser Disk Player and the Main Computer Board. Two potentiometers on the TAOS board (**R7 & R8**) **adjust the BALANCE between the Laser Disk Player and the Main Computer Board.** The audio portion of the TAOS board also provides approximately 8-watts/channel of amplification for driving a pair of 8 ohm speakers.

The TAOS board provides an **additional 9-pin "D"-style connector (J102) for a 2nd gun.** Multiplexing for the 2nd gun is also provided. **The TAOS board is mandatory for 2-player operation.** A **new connector (J105) for interfacing with a ticket dispenser** is also provided.

TAOS board **jumper JP2** affects 1-player or 2-player operation. For 2-player operation, **JP2** should be jumpered to the 2-PLAYER position. For single-player games, the gun should be connected to J101 (right gun). When a single player game is in a 25" game cabinet (no separate console) which has two START switches, these two START switches are wired in parallel to the blue LEFT START game harness wire... and the purple RIGHT START wire is disconnected at the RIGHT START switch. On 33" & 50" single-player games, an alternative configuration might be JP2=1 PLAYER LEFT with the gun plugged into TAOS board connector J102 (left gun input). Please see the TAOS board diagram in this manual for the JP2 location & positions. The PC board silkscreen shows 2-PLAYER, 1-PLAYER LFT, and 1-PLAYER RT jumper positions for JP2.

Please refer to the TAOS board schematics and the COMPONENT & CONNECTOR LOCATIONS IN EQUIPMENT TRAY diagram in this manual for additional details.

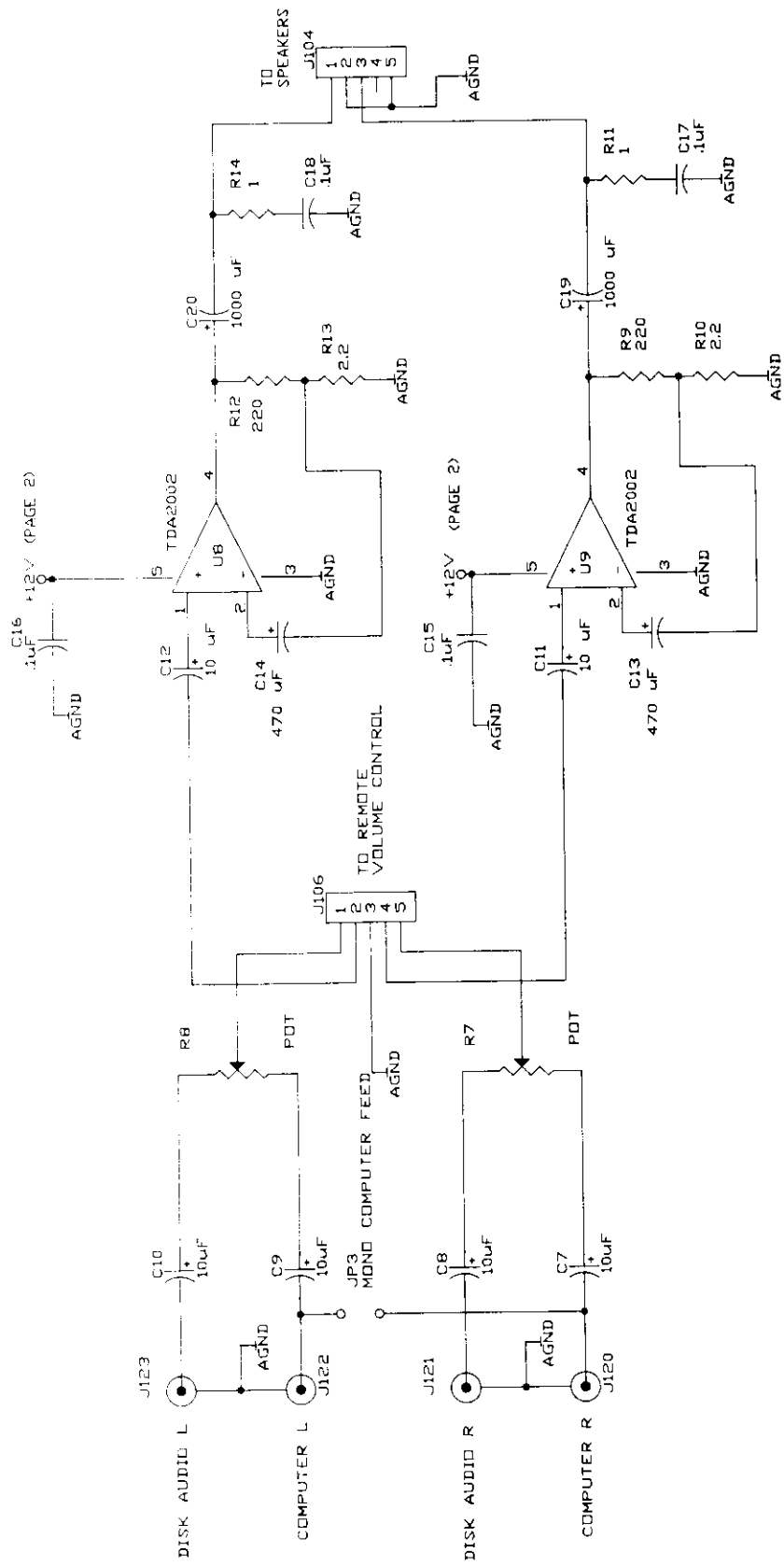

TITLE		TADS BOARD	
ORIGINATOR		AUDIO AMPLIFIER SECTION	
DATE	2/29/92	PAGE	OF
NUMBER	1	REV	DATE
		1.2	9/8/92

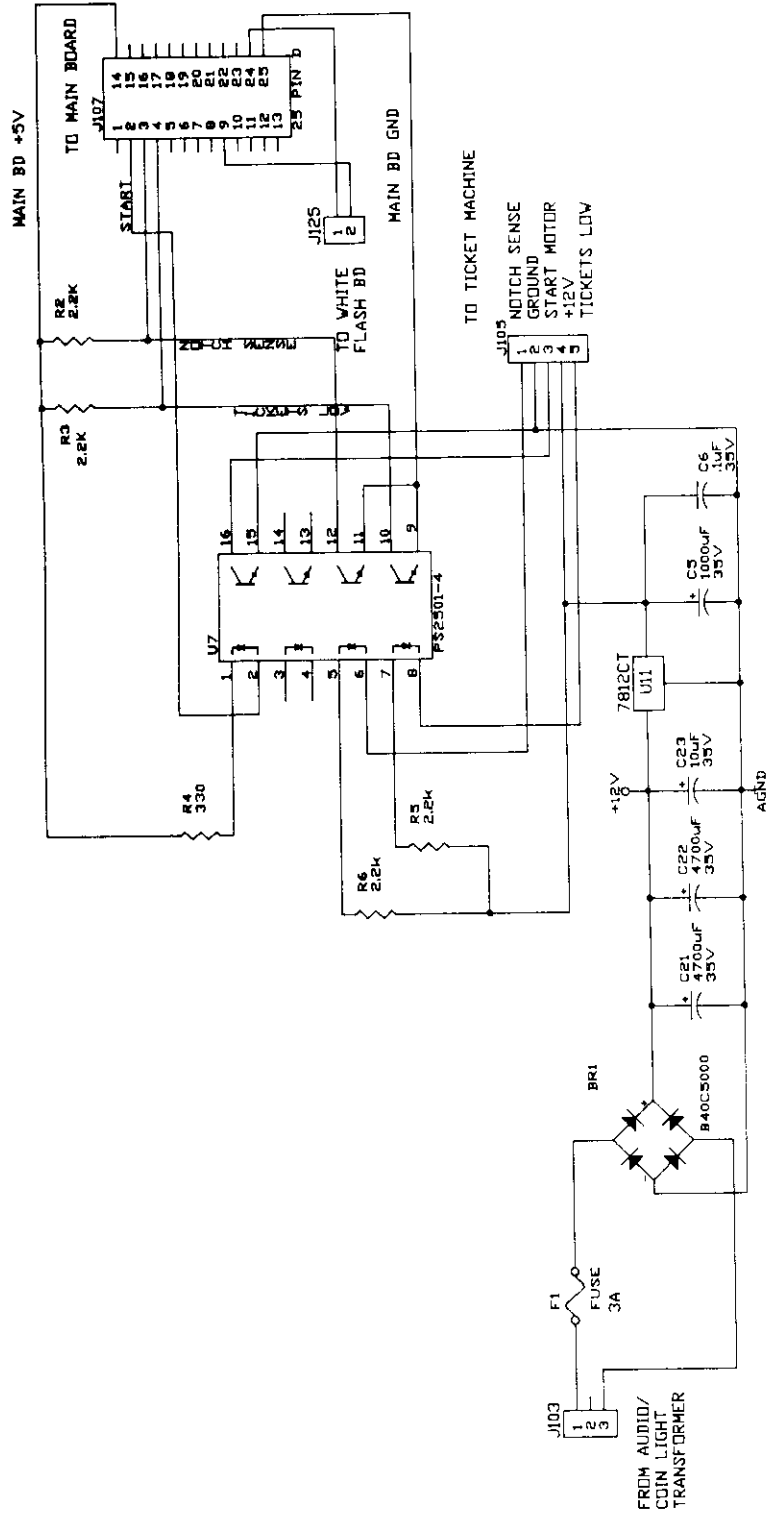

TITLE		TADS BOARD	
		12 VOLT POWER SUPPLY AND	
		TICKET MACHINE INTERFACE SECTION	
ORIGINATOR	DATE	PAGE	OF
BOB HARBOUR	2/29/92	2	4
NUMBER	REV	DATE	
	1.2	9/8/92	

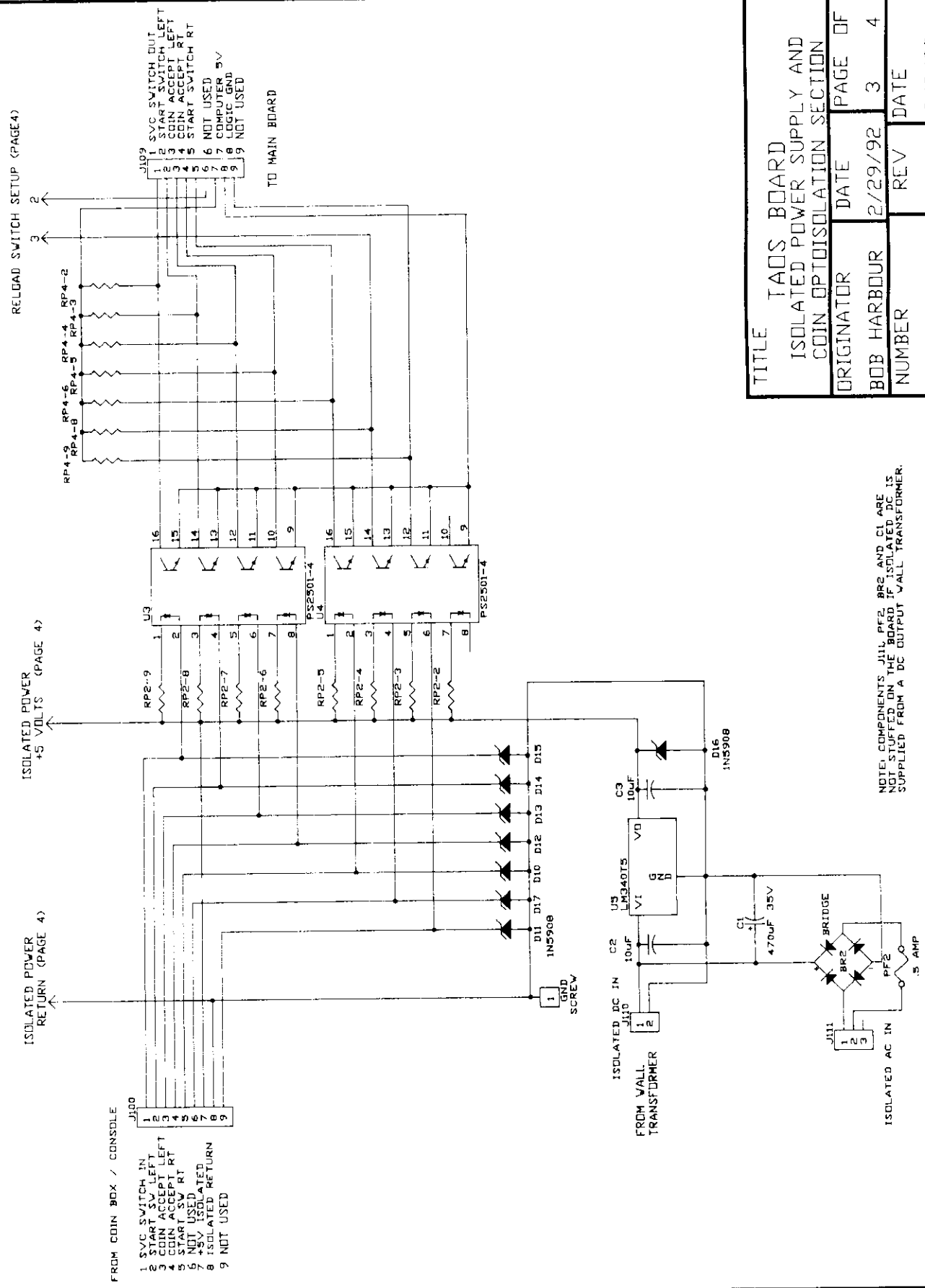

NOTE: COMPONENTS J11, PF2, BR2 AND C1 ARE NOT STUFFED ON THE BOARD IF ISOLATED DC IS SUPPLIED FROM A DC OUTPUT WALL TRANSFORMER.

TITLE		TADS BOARD	
ISOLATED POWER SUPPLY AND		PAGE OF	
COIN OPTOISOLATION SECTION		3 4	
ORIGINATOR	DATE	REV	DATE
BOB HARBDOR	2/29/92	1.2	9/8/92
NUMBER			

J108 LEGEND
 TO GAME 80 INPUT
 1 RELOAD OUT
 2 TRIGGER OUT
 3 SHOT SENSE OUT
 4 LOGIC GND
 5 COMPUTER 5V
 6 SELECT A/W/B

J101, J102 LEGEND
 TO GUNS
 1 RELOAD IN
 2 NET USED
 3 TRIGGER IN
 4 SHOT SENSE IN
 5 SW/1 TO A/B
 6 SW/2 TO RETURN

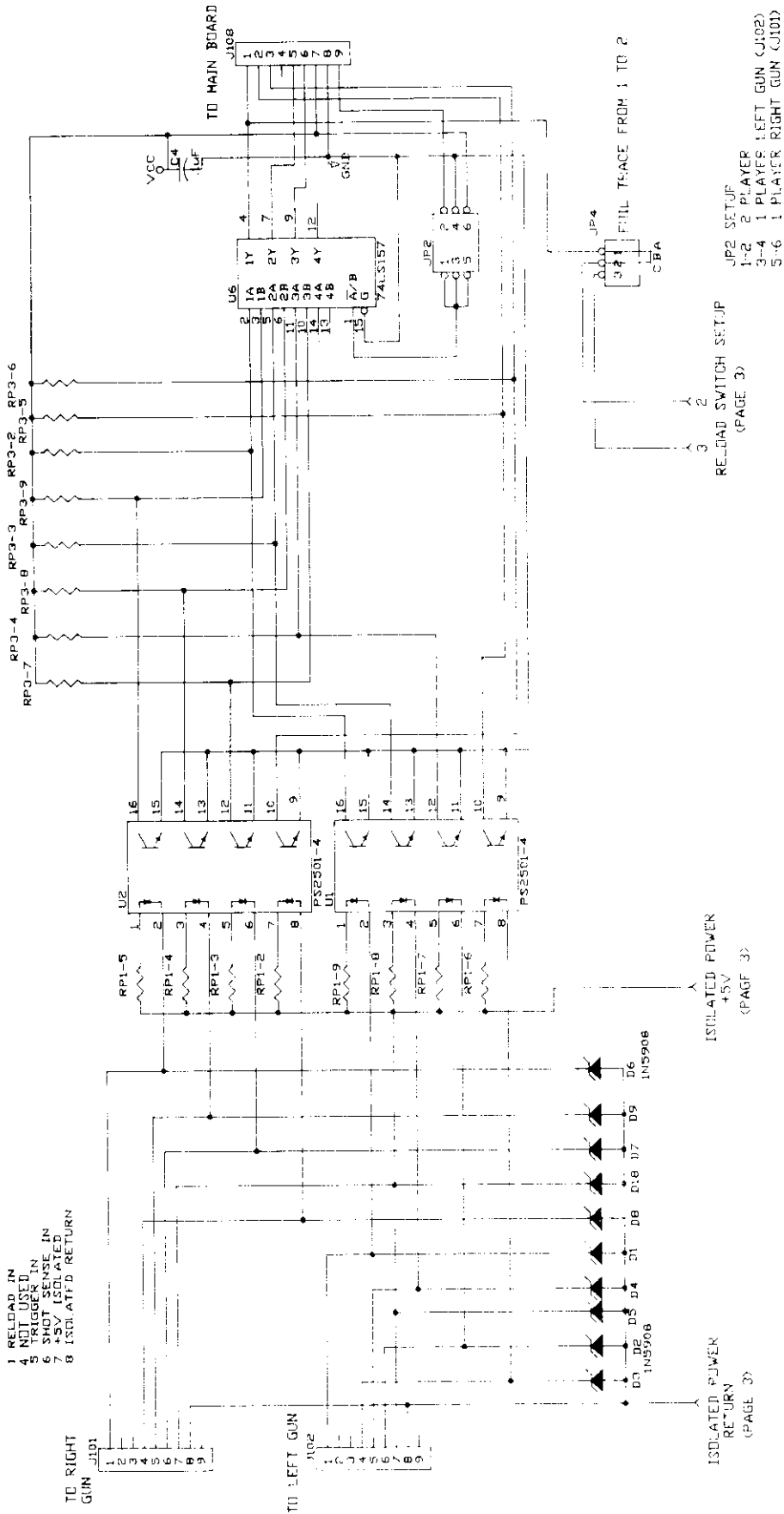

ISOLATED POWER
 4.5V
 (PAGE 3)

ISOLATED POWER
 RETURN
 (PAGE 3)

RELOAD SWITCH SETUP
 (PAGE 3)

JP2 SETUP
 1-2 2 PLAYER LEFT GUN (J102)
 3-4 1 PLAYER LEFT GUN (J101)
 5-6 1 PLAYER RIGHT GUN (J101)

TITLE		TADS BOARD	
GUN OPTICISATION/SELECTION		SECTION	
ORIGINATOR	DATE	PAGE	OF
BOB HARBOUR	2/29/92	4	4
NUMBER	REV	DATE	
	1.2	9/8/92	

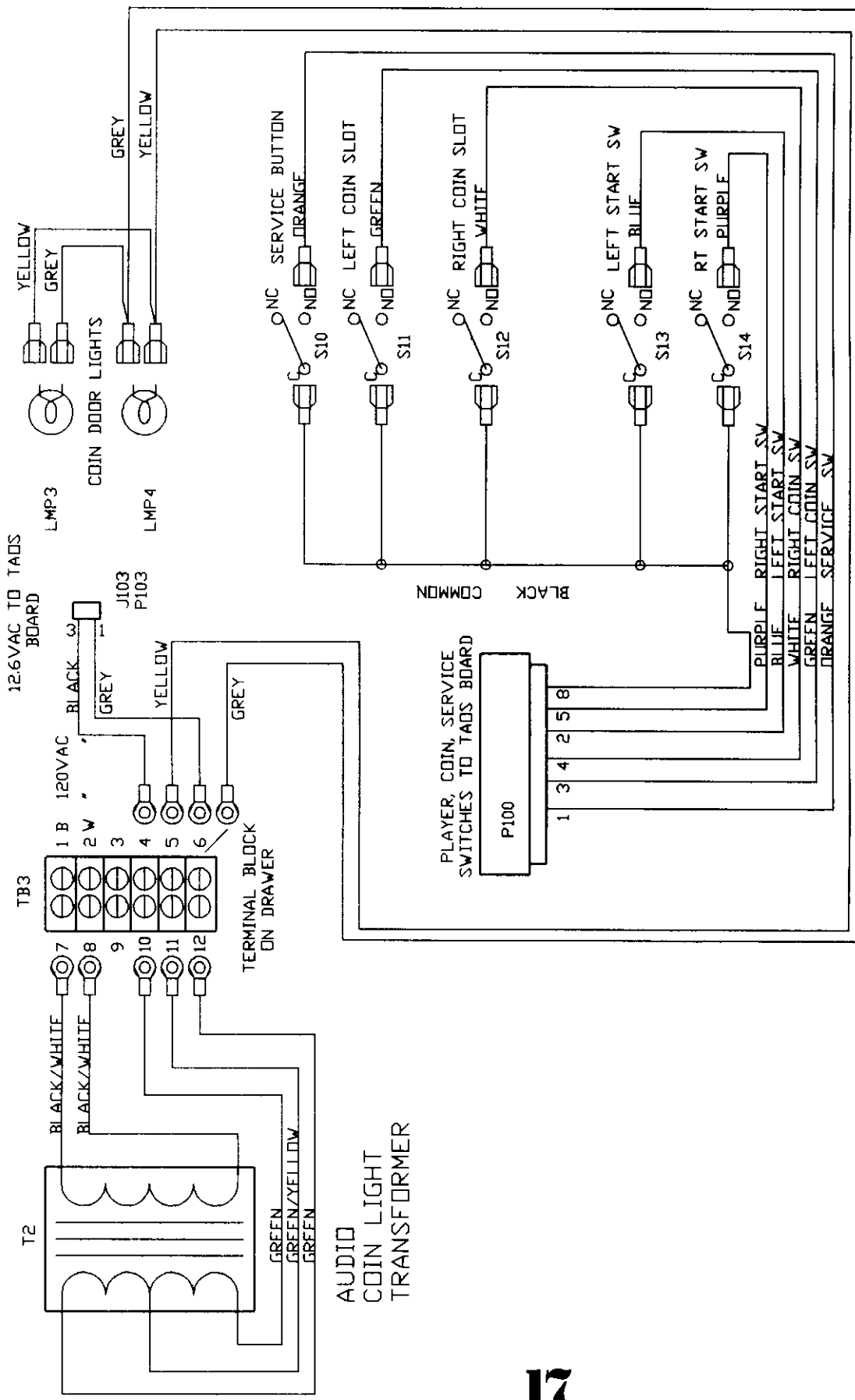

TITLE TARGET GAME LOW VOLTAGE HARNESS		
ORIGINATOR BOB HARBOUR	DATE 1/27/92	PAGE OF 1 3
NUMBER	REV 1.1	DATE 2/28/92

REMOTE VOLUME CONTROL
INPUT ON TADS BOARD

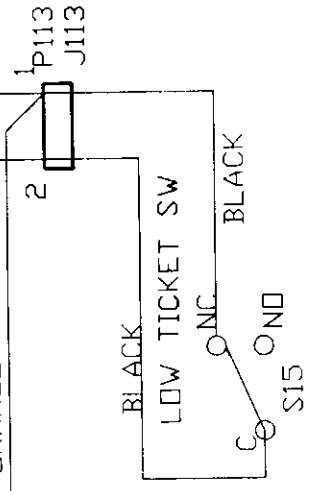
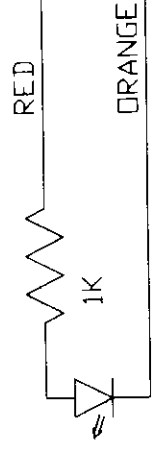
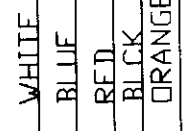
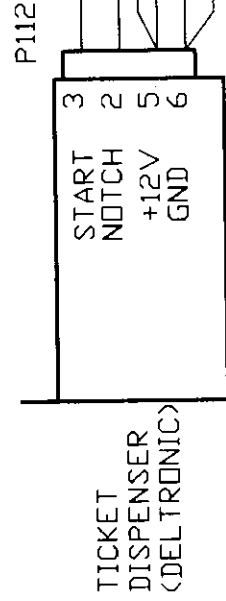
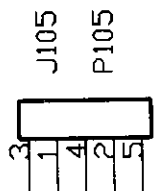
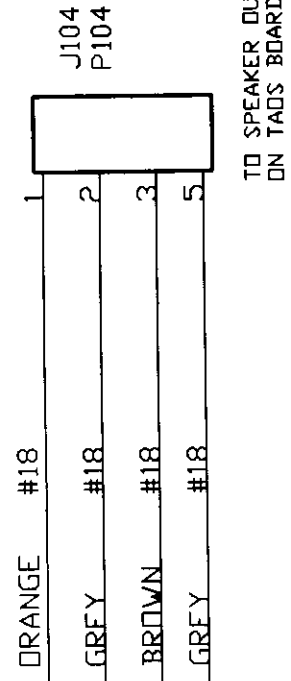
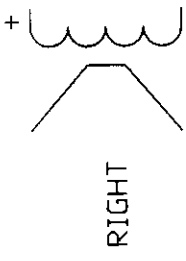
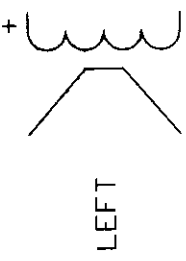
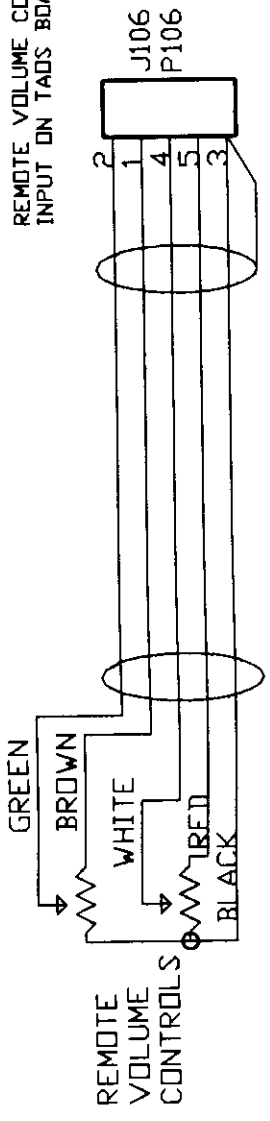

TITLE TARGET GAME			
LOW VOLTAGE HARNESS			
ORIGINATOR	DATE	PAGE	OF
BOB HARBOUR	1/27/92	2	3
NUMBER	REV	DATE	
	1.1	2/28/92	

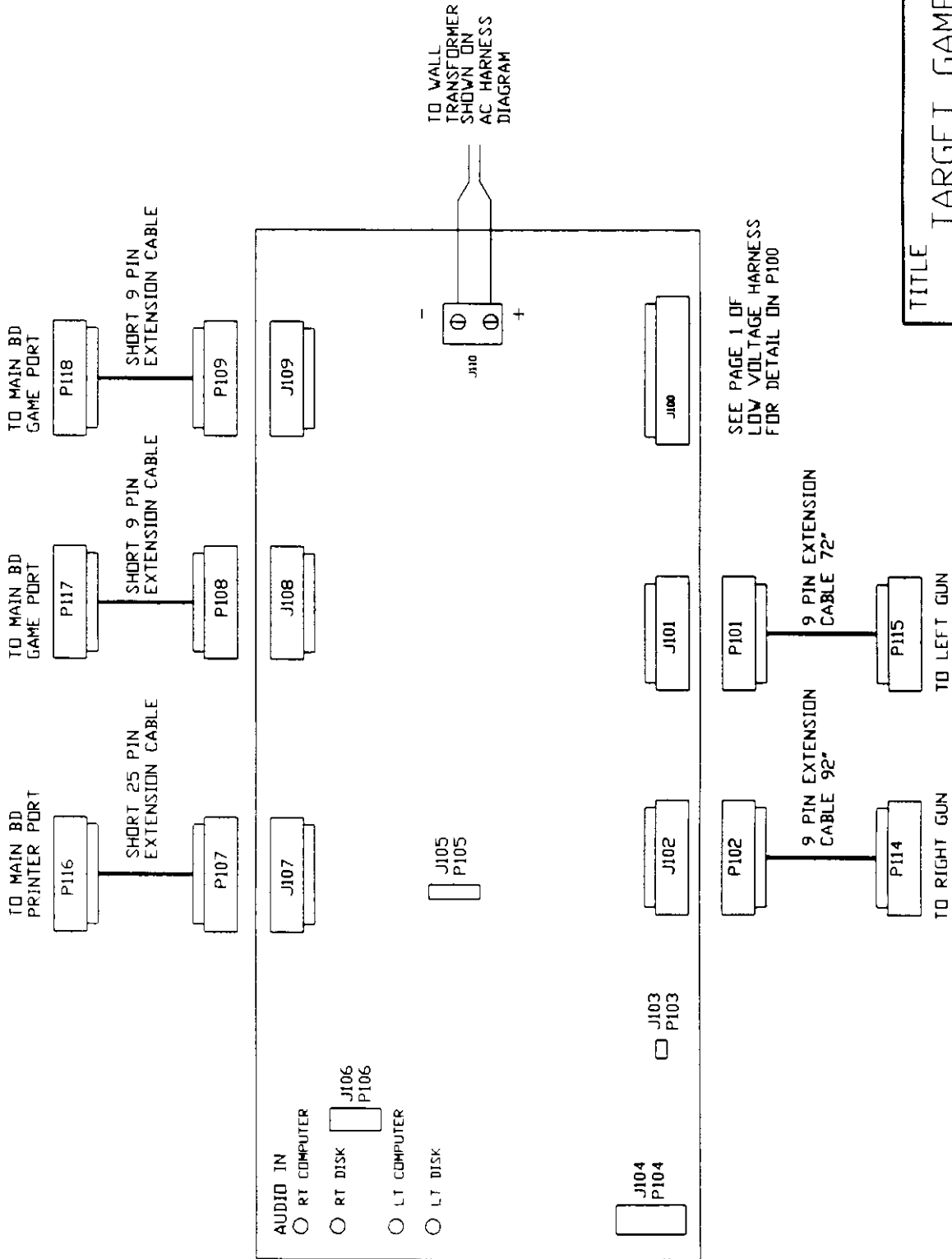

TITLE		TARGET GAME	
LOW VOLTAGE HARNESS		ORIGINATOR	DATE
BOB HARBOUR	1/27/92	PAGE OF	3
NUMBER	REV	DATE	2/28/92
	11		

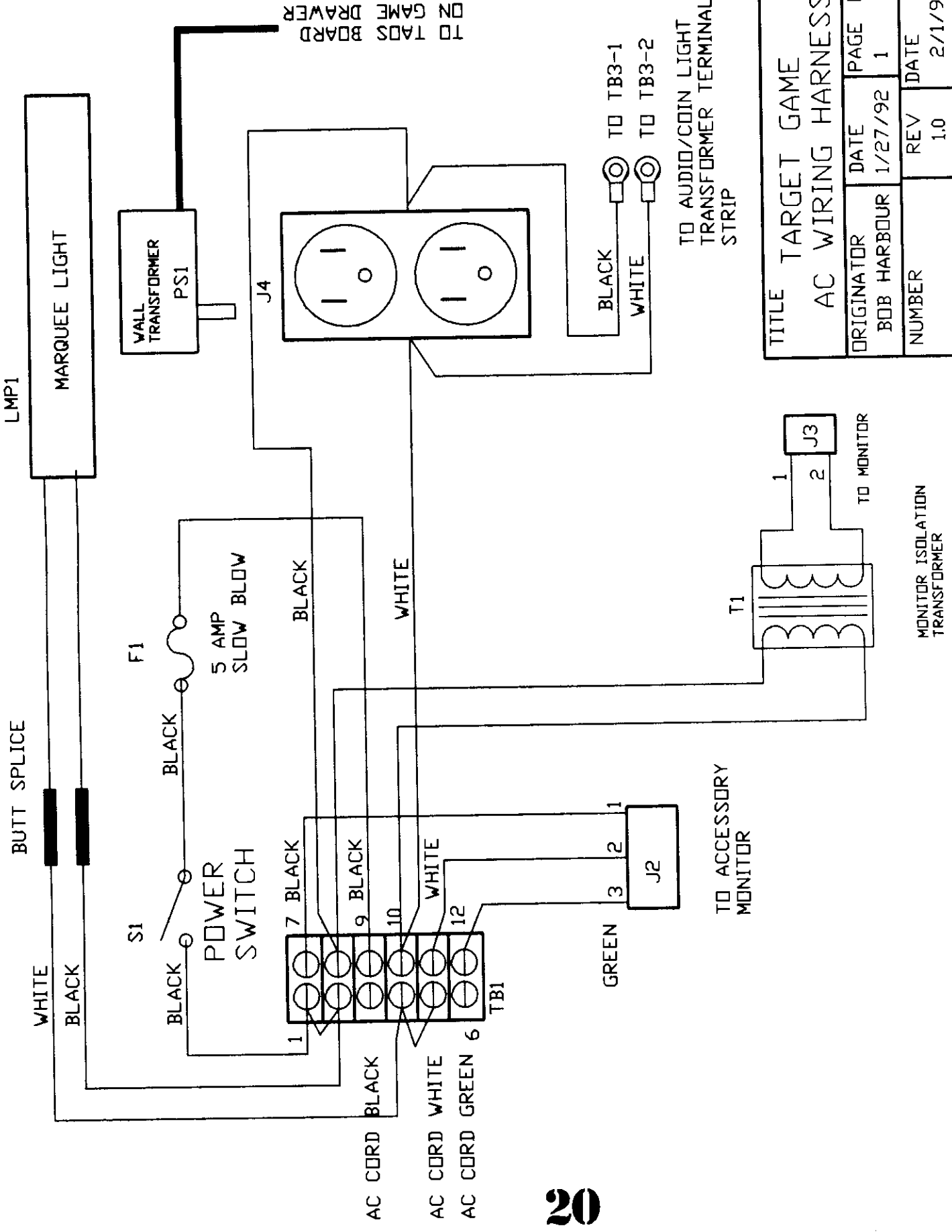

TITLE TARGET GAME			
AC WIRING HARNESS			
ORIGINATOR	DATE	PAGE	OF
BOB HARBOUR	1/27/92	1	2
NUMBER	REV	DATE	
	1.0	2/1/92	

MONITOR ISOLATION TRANSFORMER

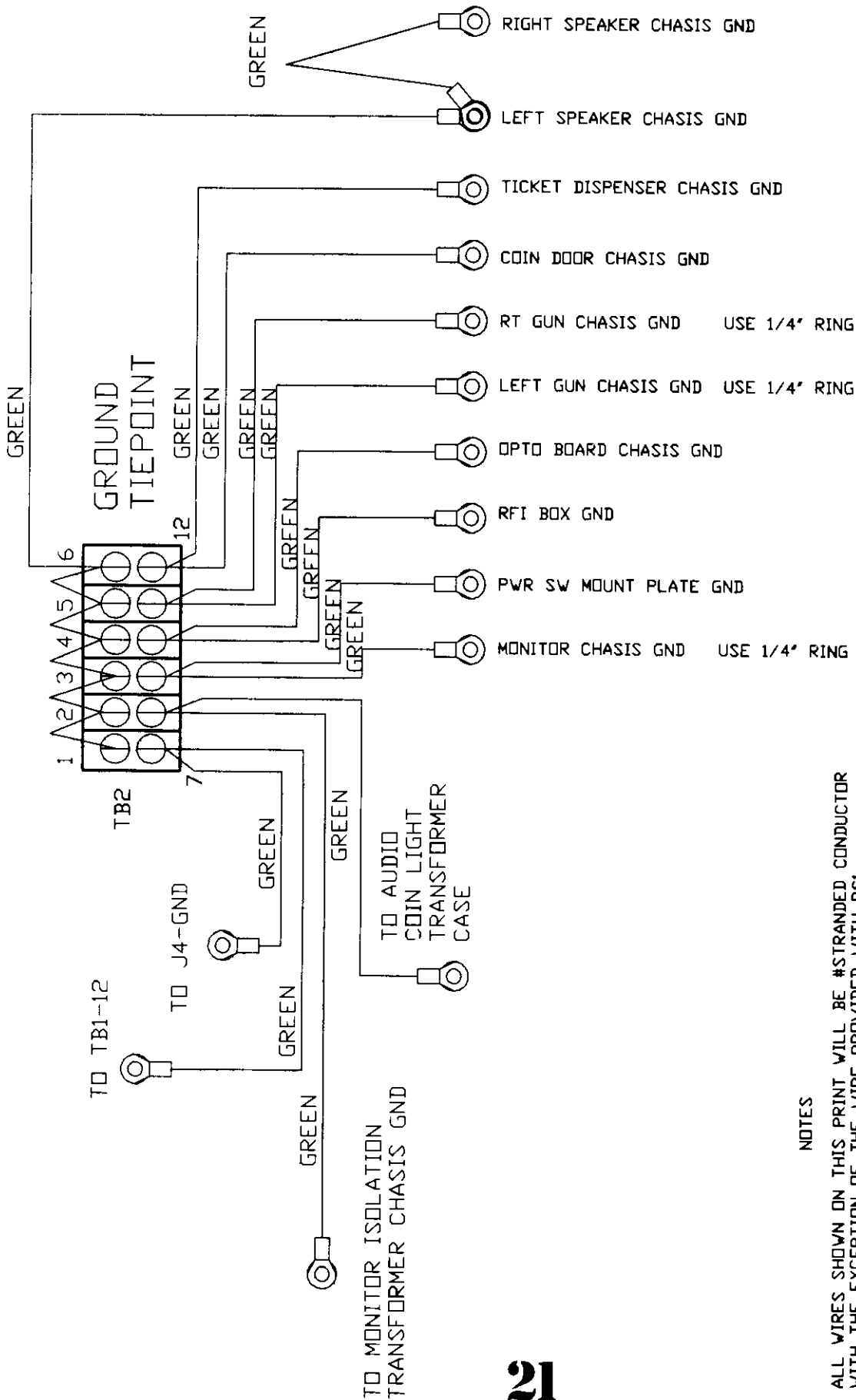

NOTES

ALL WIRES SHOWN ON THIS PRINT WILL BE #STRANDED CONDUCTOR WITH THE EXCEPTION OF THE WIRE PROVIDED WITH PSI

- TB1 INPUT POWER DISTRIBUTION, MOUNTED ON AC PLATE
- TB2 CHASSIS GROUND POINT, MOUNTED ON AC PLATE
- TB3 AUDIO/COIN LIGHT POWER TRANSFORMER INTERCONNECT, MOUNTED ON DRAWER
- S1 POWER SWITCH, MOUNTED AT TOP REAR OF CABINET
- F1 MAIN POWER FUSE, MOUNTED ON AC PLATE
- LMP1 MARQUIS LIGHT, MOUNTED AT TOP FRONT OF CABINET
- J2 POWER SUPPLY TO ACCESSORY MONITOR, TIE TO HARNESS NEAR POWER SWITCH
- J3 ISOLATED POWER FOR MONITOR.
- T1 ISOLATION TRANSFORMER FOR MONITOR, MOUNTED ON AC PLATE
- J4 DUPLEX AC OUTLET, MOUNTED ON AC PLATE
- PS1 WALL PLUG TRANSFORMER STANCOR W120DUJ50-1 ,PLUGS INTO J4

TITLE TARGET GAME		DATE	PAGE	OF
AC WIRING HARNESS		1/27/92	2	2
ORIGINATOR	BOB HARBOUR	REV	DATE	
NUMBER		1.0	2/1/92	

TAOS BOARD COMPONENT LOCATOR (Rev. 1.2)

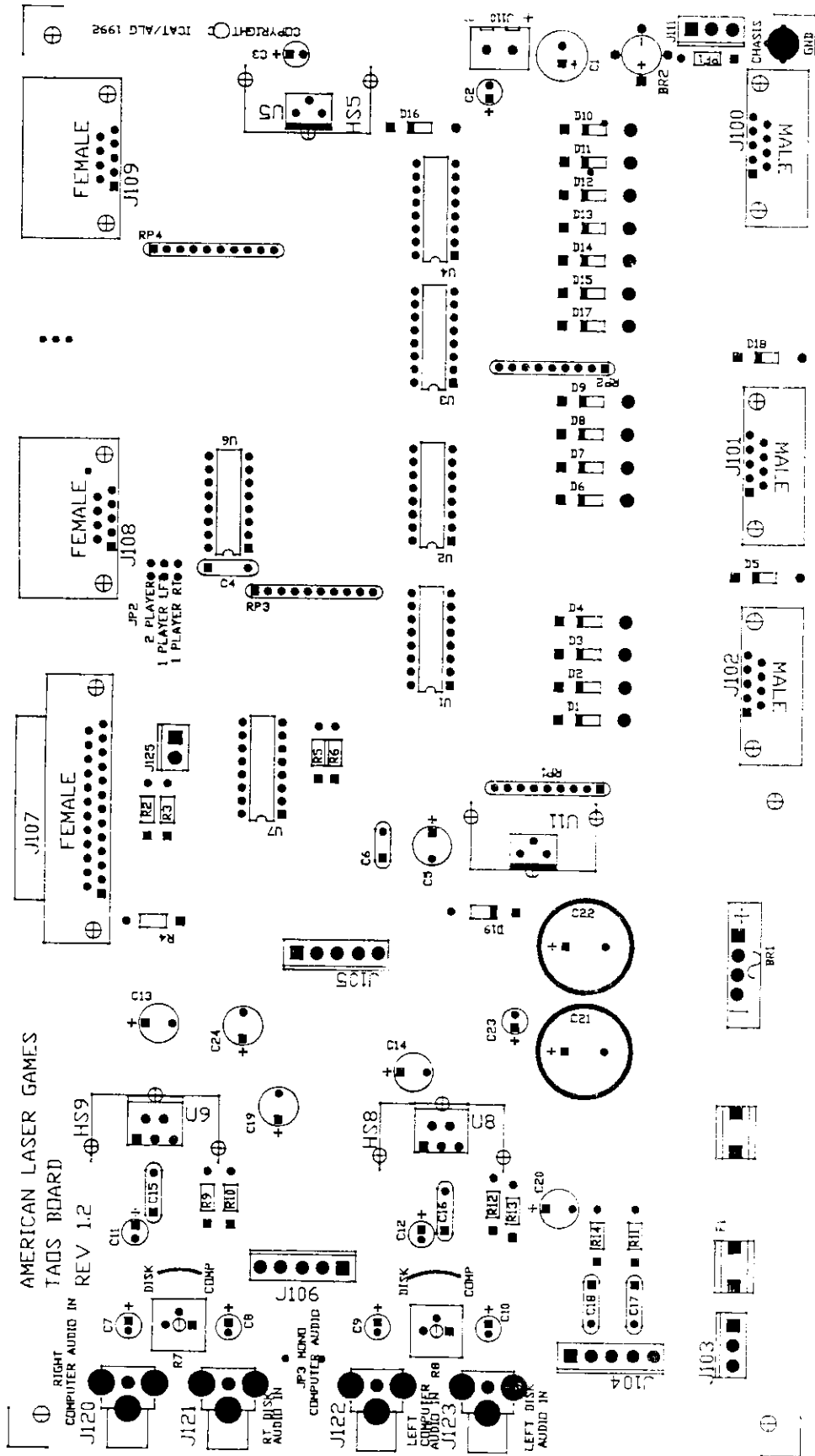

TAOS (OPTOISOLATOR/AUDIO AMPLIFIER) BOARD

Revised: 27 April 1993

Bill Of Materials (pg. 1 of 2)

TAOS Rev. 1.2

Item	Quantity	Reference	Part
1	1	BR1	BRIDGE RECTIFIER B40C5000 GENERAL INSTRUMENTS
2	1	BR2	-not stuffed-
3	1	C1	470 uF 35V (NOT STUFFED)
4	3	C2,C3,C23	10 uF 35V TANTALUM
5	6	C7,C8,C9, C10,C11,C12	10 uF 25V ALUMINUM ELECTROLYTIC
6	6	C4,C6,C15,C16, C17,C18	0.1 uF 25V CERAMIC OR CK05 Kemet C410C104M5U5CA
7	2	C13,C14	470 uF 25V ALUMINUM ELECTROLYTIC
8	4	C5,C19,C20,C24	1000 uF 25V ALUMINUM ELECTROLYTIC
9	2	C21,C22	4700 uF 25V ALUMINUM ELECTROLYTIC
10	18	D1,D2,D3,D4,D5,D6, D7,D8,D9,D10,D11, D12,D13,D14,D15, D16,D17,D18	1N5908 TRANSORBS
11	1	F1	FUSE 3A SLOW BLOW 3AG-3A generic
12	2	F1 MOUNT	FUSE HOLDER CLIPS
13	1	F1COVER	FUSE COVER P/N 840832 or ALG P/N 1010070
14	3	J100,J101,J102	9 PIN D CONNECTOR, MALE RIGHT ANGLE PC MOUNT
15	2	J108,J109	9 PIN D CONNECTOR, FEMALE RIGHT ANGLE PC MOUNT
16	3	J104,J105,J106	5 PIN .156 MOLEX MALE Molex 26-64-4050
17	1	J107	25 PIN D CONNECTOR,FEMALE RIGHT ANGLE PC MOUNT Molex 8200-8352
18	1	J110	2 POSITION SCREW TERMINAL MOUNT
19	2	J111,J112	3 PIN .156 MOLEX MALE Molex 26-64-4030
20	4	J120,J121,J122,J123	RCA FEMALE RIGHT ANGLE PC MOUNT Marshall Electronics Inc C4426 Switchcraft 3517PC
21	1	J125	2 PIN .156 MOLEX MALE Molex 26-60-4020
22	2	JP2	1x3 .025" square posts P/N 3623B-43 or ALG P/N 4030027
23	1	JS2	Jumper Shunt (for JP2) P/N SNT-100-BK-G or ALG P/N 4030045
24	0	L1	-deleted-
25	0	PF2	-deleted-

TAOS (OPTOISOLATOR/AUDIO AMPLIFIER) BOARD

Revised: 27 April 1993

Bill Of Materials (pg. 2 of 2)

TAOS Rev. 1.2

Item	Quantity	Reference	Part
26	0	Q1	-deleted- (was 2N2222A NPN TRANSISTOR)
27	2	RP1,RP2	330 OHM x 9 SIP RESISTOR Dale 9X-1-331
28	2	RP3,RP4	4.7K x 9 SIP RESISTOR Dale 09A1-472G
30	0	R1	-deleted-
31	4	R2,R3,R5,R6	2.2K 1/4 WATT (RED,RED,RED,GOLD) generic
32	1	R4	330 Ohm 1/4 WATT (ORANGE,ORANGE,BROWN,GOLD) generic
33	2	R7,R8	POT 10K PC MOUNT POTENTIOMETER Bourns 3386P-103T (preferred) Bourns 3386P-103
34	2	R9,R12	220 Ohm 1/4 WATT (RED,RED,BROWN,GOLD) generic
35	2	R11,R14	1 Ohm 1/4 WATT (BROWN,BLACK,GOLD,GOLD) generic
36	2	R10,R13	2.2 Ohm 1/4 Watt (RED,RED,GOLD,GOLD) generic
37	5	U1,U2,U3,U4,U7	PS2501-4/TLP621-4 (quad) or TLP621-2 (dual) OPTOCOUPERS
38	1	U5	LM340T5 or MC7805CT
39	1	U6	74LS157 OR 74HCT157 generic
40	2	U8,U9	TDA2002 OR LM2002 SGS Thompson or National
41	4	HS5,HS8,HS9,HS11	Heat Sinks for TO-220 packages Keystone 7-190-BA
42	1	U11	LM340T12 or MC7812CT
43	1		Bare Printed Circuit Board from SND_OPT2 1.2 REV artwork

MONITOR & WHITE SOURCE BOARD ADJUSTMENT PROCEDURE FOR 25" GAMES WITH HANTAREX MONITORS

Game/gun performance is best when the monitor and the "white source" board are properly adjusted. They have been set at the factory, but this procedure is provided if you should later find it necessary adjust the game video. The white source board directly drives the RGB video lines during a one-frame white flash after a gun trigger is pulled. The white source board allows you to adjust for pleasing monitor color and yet have a bright white flash.

1) Adjust monitor **brightness, contrast, color, and tint** using the four pots on the NTSC-to-RGB board. Adjust for a sharp, pleasing image. The NTSC-to-RGB board is the left-hand board in the monitor chassis (when viewed from the rear of the cabinet) and may be identified as the board to which the video cable from the equipment tray connects. The **top pot** adjusts brightness, the next contrast, the next color, and the bottom pot adjusts tint. See the inserted page in the monitor manual for details of this board.

2) **If you have an oscilloscope**, measure the **peak RGB video levels** after making the above adjustments. These signals may be measured either at the red, green, and blue wires of CA connector on the right-hand (main) monitor PC board or at J1/J2/J3 on the white source board. Look for the 6-conductor cable with red/green/blue/black/yellow/white wires.

3) **Locate the small (2" x 3") "white source board"** on the monitor chassis between the two big monitor circuit boards. Observe the **two voltage regulators, Q7 & Q8** (adjacent TO-220 packages) on the white source board. The white source voltage may be measured by connecting a voltmeter to the TABS of Q7 and Q8. Connect the ground lead to the tab of Q8. Connect the positive voltmeter lead to the tab of Q7. It is not necessary to pull the gun trigger when measuring the white source voltage. Adjust potentiometer R18 so the voltmeter reads approximately 20% higher than the highest peak video level measured in step 2) above. Skip to step 4).

If you don't have access to an oscilloscope, adjust the R18 pot on the white source board so you begin to **see re-trace lines when the screen flashes white** as you rapidly pull the gun trigger. Back off the pot until the retrace lines disappear.

4) Use the game SERVICE switch to **select the GUN CALIBRATION screen**. Then locate the monitor voltage control (labeled "SCREEN") on the right-hand main monitor circuit board near the high-voltage supply. This pot is the lower (closer to the circuit board) of the two adjacent controls. The other nearby control is the FOCUS control potentiometer. (Refer to the monitor manual if you're unsure where this control is.) **Adjust the SCREEN control until you get good gun performance over the shooting area of the screen**. Note that there are no targets very near the edges & corners of the screen nor below the bottom line of text in the GUN CALIBRATION screen (in the SERVICE mode). Also, since monitor output is lower in these regions, you do not need to adjust the SCREEN control for shooting at these locations.

Do not adjust the SCREEN control excessively high as monitor damage will result.

Note: The WHITE SOURCE BOARD directly drives the monitor RGB inputs and it therefore separates the normal video intensity from the intensity of the white flash that the gun detects after the trigger is pulled. The white source board will drive the video to maximum brightness during one frame after each gunshot. Therefore, it is NOT necessary to have normal video at maximum brightness.

GUN SHOT BOARD COMPONENT LOCATOR

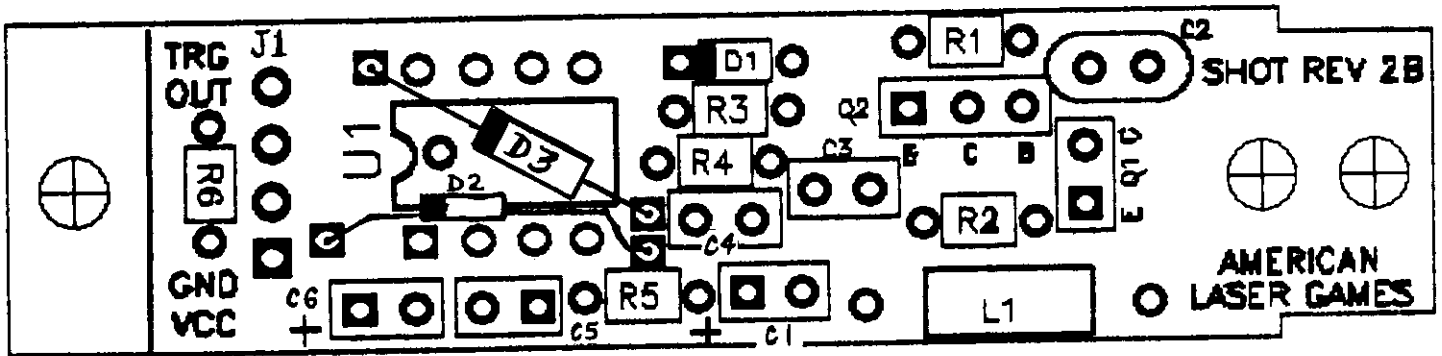

D2 and D3 mount above U1 (after U1 is inserted)

GUN SHOT BOARD Revised: April 27, 1993 Bill Of Materials

Item	Quantity	Reference	Part
1	3	C1,C4,C6	10 uF 16 volt tantalum capacitor
2	2	C2,C5	0.1 uF capacitor
3	1	C3	10 pF ceramic disk capacitor
4	1	D1	1N4148 diode
5	2	D2,D3	SA5.0 Transorbs
6	1	J1	4 pin, 0.1 inch center, rt. angle header
7	1	L1	5.6 mH inductor
8	1	Q1	MRD-310 phototransistor (Motorola)
9	1	Q2	2SC458C NPN transistor (Hitachi high beta)
10	1	R1	75K 1/8 watt resistor
11	1	R2	51K 1/8 watt resistor
12	1	R3	820 ohm 1/8 watt resistor
13	2	R4,R6	1K 1/8 watt resistor
14	1	R5	47 ohm 1/8 watt resistor
15	1	U1	LM-311 comparator IC
16	1		Bare printed circuit board from CS3 rev artwork

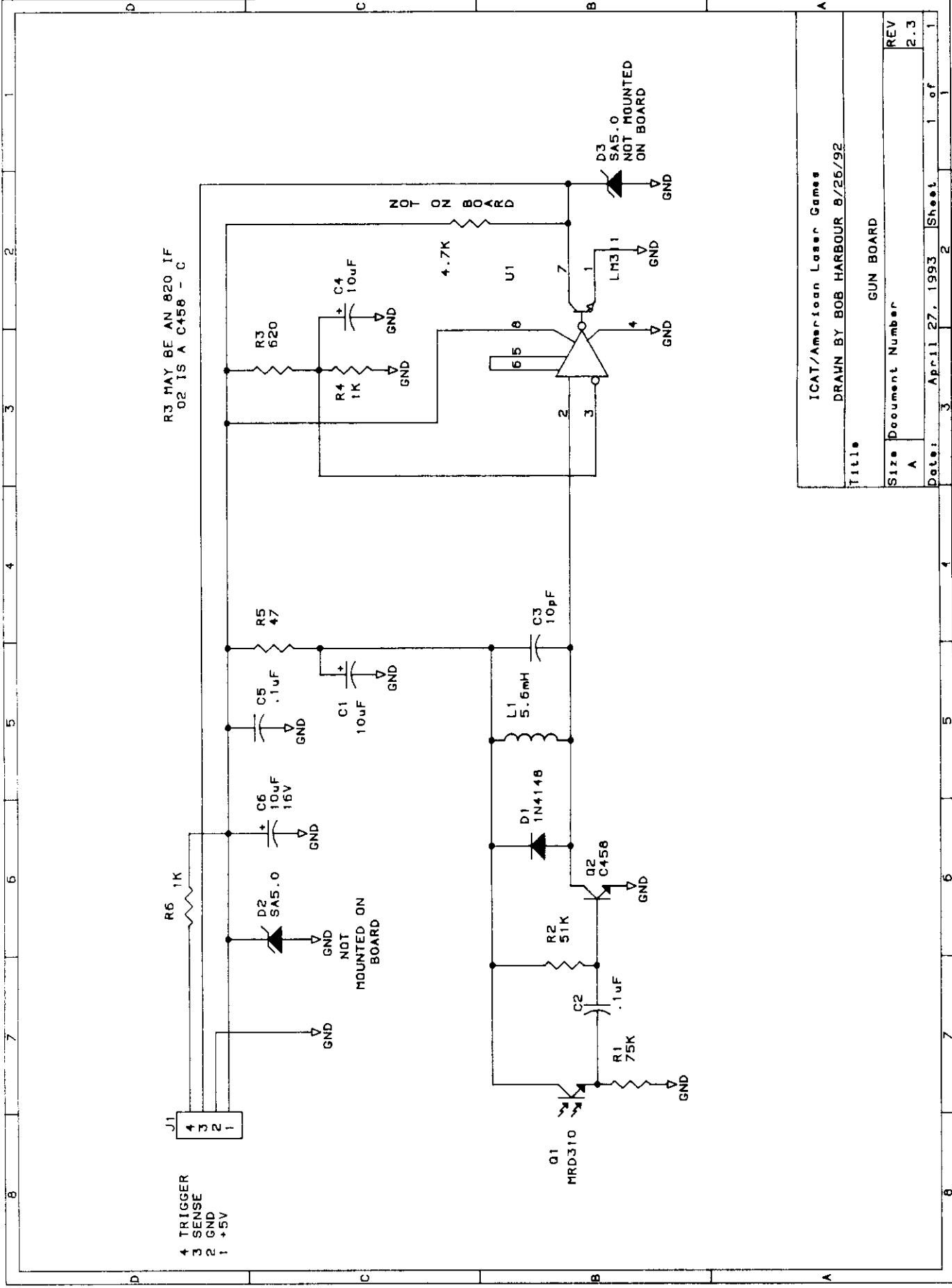

OPTOISOLATOR BOARD ASSEMBLY BILL OF MATERIALS

30 April 1993

(This board has been replaced by TAOS board)

ITEM #	QTY	REFERENCE	DESCRIPTION
1	4	U1--U4	Optoisolator, quad, 16-pin (TLP621-4 or PS2501-4)
2	0	Q1	--Omitted-- (transistor, 2N3906)
3	1	Q2	Voltage regulator, LM340T5 or 7805 (mounts on backside of PCB)
4	16	D1--D7 D10--D18	Transzorb, 1N5908, Motorola
5	0	D8, D9	--Omitted-- (Transzorbs)
6	0	C1	--Omitted-- (capacitor, 10 pF, 16V)
7	1	C2	Capacitor, tantalum, 10 uF 35V, teardrop style
8	1	C3	Capacitor, tantalum, 10 uF 35V, teardrop style
9	2	RP1, RP2	SIP resistor pack, 330 ohm, 9-pin in 10-position site
10	1	RP3	SIP resistor pack, 4.7K ohm, 9-pin in 10-position site
11	1	R1	--Omitted-- (resistor, 1K ohm, 1/4 watt)
12	1	R2	Resistor, 330 ohm, carbon, 1/4 watt, 5%
13	2	P1, P3	Connector, MALE, 9-pin rt. angle D-sub, PCB mount
14	2	P2, P4	Connector, FEMALE, 9-pin rt. angle D-sub, PCB mount
15	1	JP1	Terminal block connector, 2-position, PCB mount
16	0	JP2	--Omitted-- (?connector?)
17	1	--	Screw, machine, 4-40 x 1/4, pan head, Phillips (for Q2 mounting)
18	1	--	Nut, 4-40, plated (for Q2 mounting)
19	1	--	Bare PC board, optoisolator (P/N: 4020022)

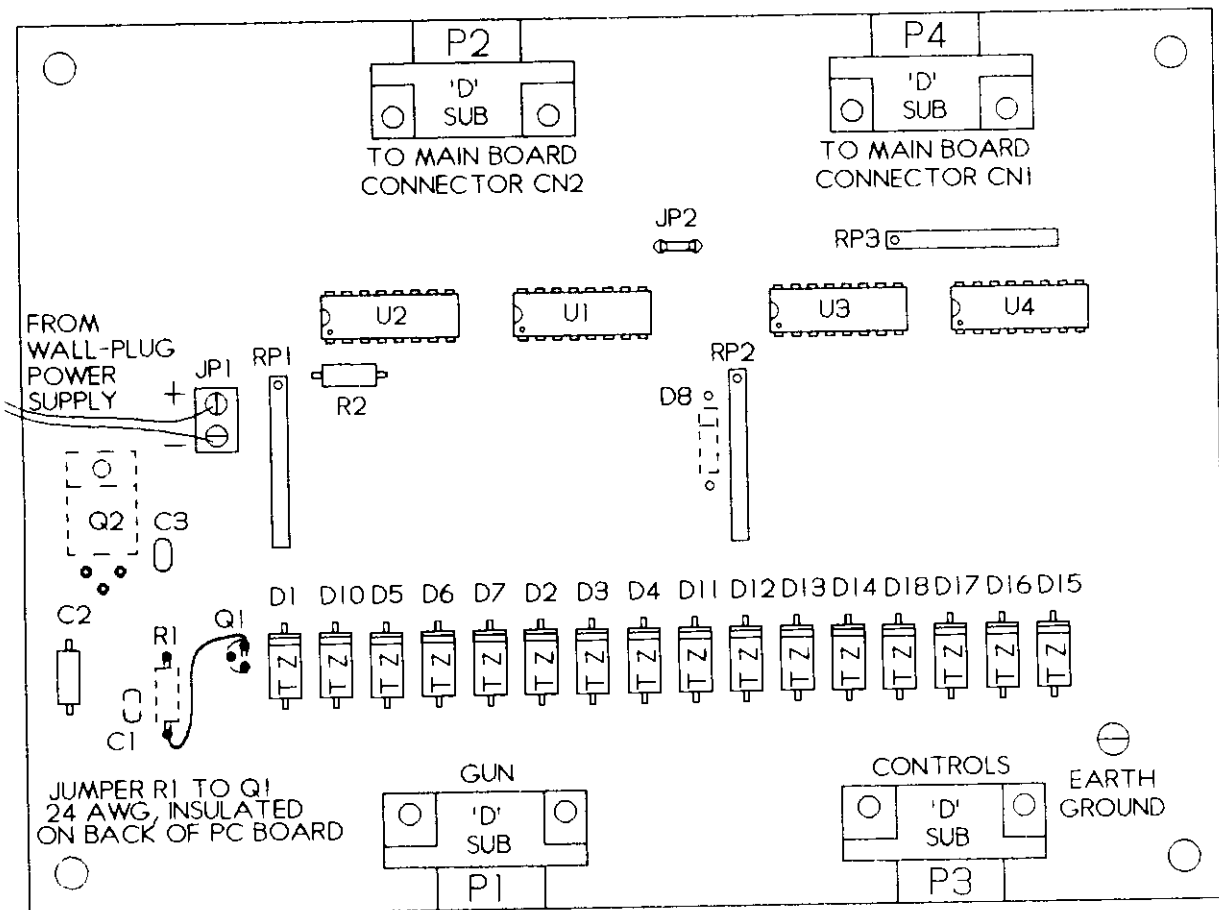

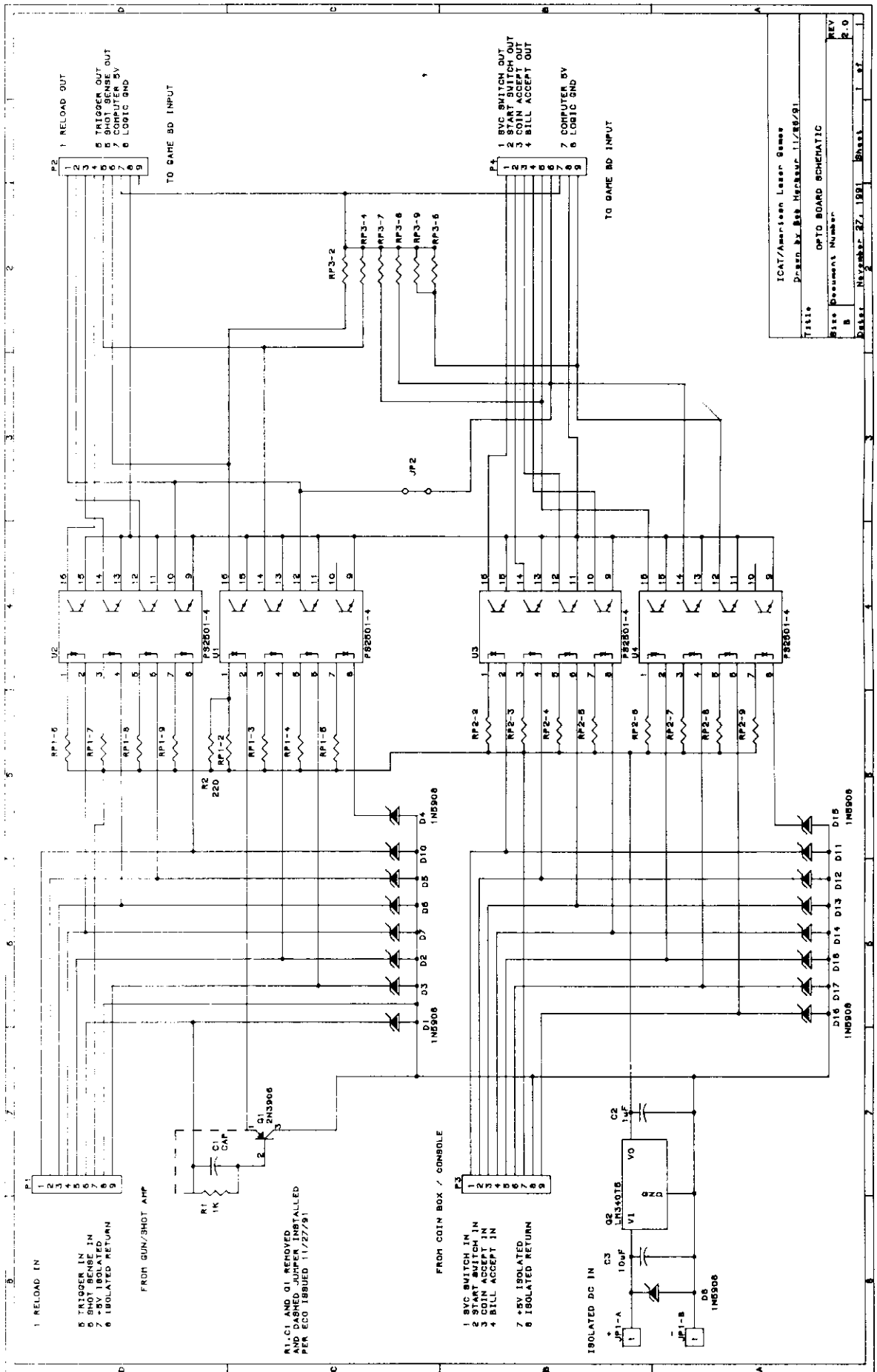

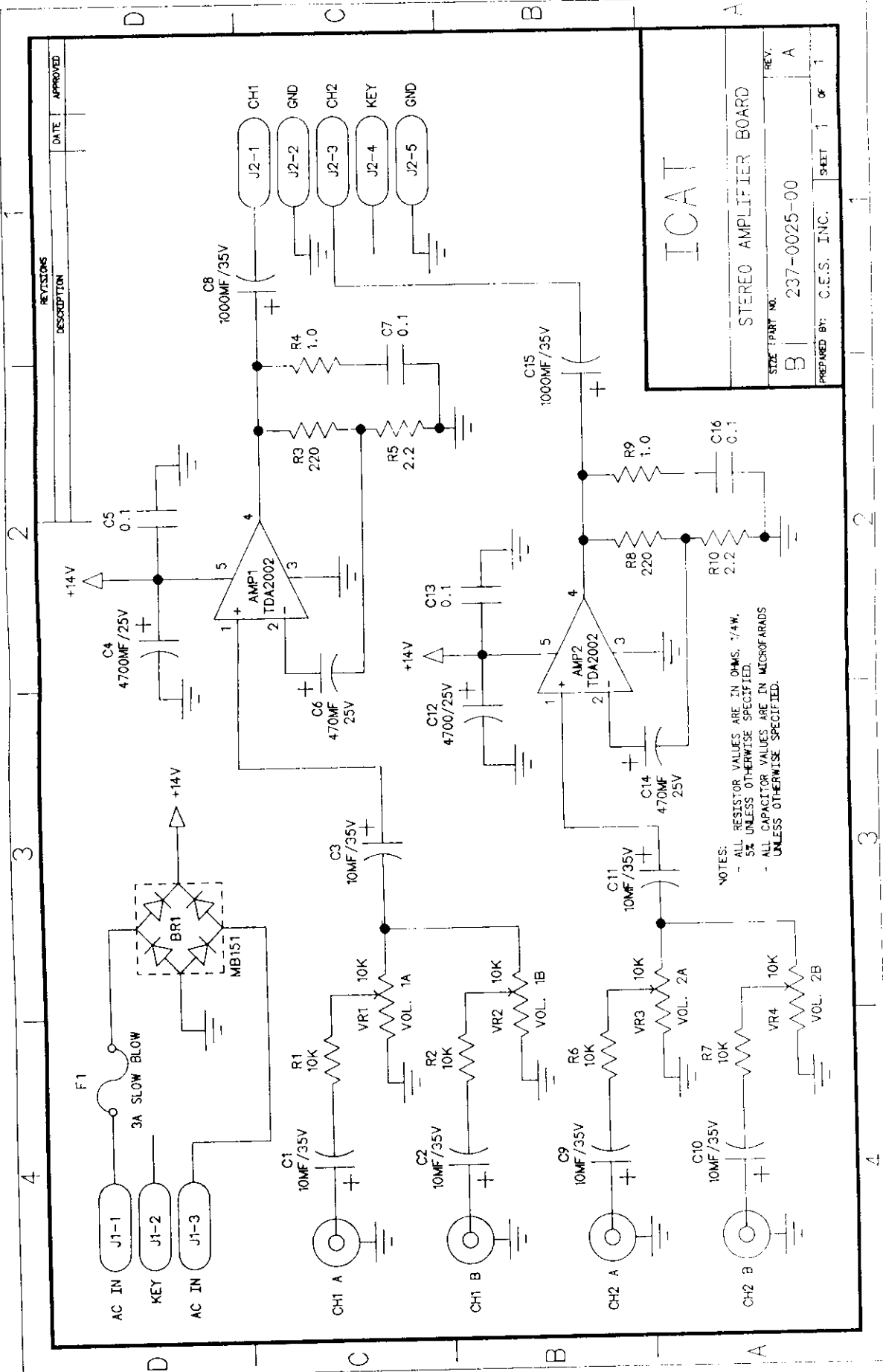

REVISIONS		DATE	APPROVED
DESCRIPTION			

ICAT

STEREO AMPLIFIER BOARD

SIZE: PART NO. **B1** 237-0025-00

REV. **A**

PREPARED BY: C.E.S. INC. SHEET 1 OF 1

- NOTES:
- ALL RESISTOR VALUES ARE IN OHMS, 1/4W, 5% UNLESS OTHERWISE SPECIFIED.
 - ALL CAPACITOR VALUES ARE IN MICROFARADS UNLESS OTHERWISE SPECIFIED.

AMERICAN LASER GAMES

TROUBLESHOOTING

Here is a list of commonly found problems and their possible solutions.

* CAUTION *

Many of the components found in the game electronics are extremely static sensitive. Exposure to static electricity may cause permanent damage or result in significantly shorter product life span. When working on the game, always wear a static bracelet that is properly grounded.

Gun won't shoot at left edge of screen:

Check gun calibration. You should balance shooting performance at the screen borders during gun calibration ... don't merely calibrate at the target in the screen center. See important details described in the **service menu** pages which follow this troubleshooting section. Check that the gun lens is clean. Check that monitor brightness is high, but not washed out. On older guns (guns without plastic tube inside gun barrel) check the alignment of the photodetector...it should point directly along the gun barrel.

Screen flashes when trigger is pulled but no shot is made.

Video intensity has been adjusted too low or gun wiring may be bad (see gun wiring diagram). Other likely causes include a bad or shorting gun shot board, an upside-down gun RELOAD mercury switch or shorted-to-ground RELOAD signal, a bad optoisolator (TAOS) board / power supply, or a bad main electronics board. Check shot board 4-pin connector & photodetector leads. On older guns, check photodetector alignment.

Erratic gun shot placement.

Replace transistor Q2 (2SC458C) on gun shot board if low beta or rectangular shape. Check that the monitor video intensity is bright. Old guns (with surface mount IC on shot board) may exhibit somewhat erratic performance. Likewise, old monitors where the video intensity has deteriorated may exhibit somewhat erratic shot placement. Also, check for dirty or cracked gun lens. Strong sunlight may possibly affect the shot placement. Monitor appears dead.

Check that the monitor power connector has not come disconnected. Check the main AC power fuse. Check power at the outlet with an AC voltmeter. Confirm that the monitor has a video signal...connect a video cable directly from the LDP to the monitor.

No gun shot sound.

Check that the RCA cable is connected between the audio output of the main electronics board and either J120 or J122 audio input on the TAOS (opto-amplifier) board. Check the remote volume control near the SERVICE switch and the volume potentiometers R8 & R7 on the TAOS (opto-amplifier) board. Check that the J3 (mono computer feed) jumper is installed on the TAOS board. Check for wiring shorts inside the gun or shorts on/near the gun shot board.

Check that the nine pin connector on the gun is connected to either J101 (right gun) or J102 (left gun) on the TAOS (opto-amplifier) board. Check that the jumper cable is connected between J108 on the TAOS board and the "GUN" input (CN2) on the main computer board. Measure the polarity and voltage (approx. 12-18 VDC) of the wall-plug transformer power at TAOS connector J110. Refer to the TAOS board diagram for the correct connector assignment.

AMERICAN LASER GAMES

Monitor appears dead.

Check that the computer board power supply is switched ON. Check that the monitor power connector has not become disconnected. Check the main AC power fuse. Check power at the outlet with an AC voltmeter. Confirm that the monitor has a video signal by connecting a video cable directly from the laser disk player to the monitor. If normal-looking video appears, the monitor & LDP are most likely OK. Reconnect the game video cables and attempt to access the service screens by pressing the SERVICE switch inside the coin door. If you saw LDP video earlier but cannot see normal service screens here, the problem is most likely the genlock or possibly the motherboard. Reseat the socketed ICs on the motherboard or replace the genlock. If the monitor appears dead for both of the above tests, it may be dead or else the LDP is not outputting video. Connect a known-good NTSC video source to the monitor and check the monitor. If it still appears dead, check all monitor cables. Connect the genlock output to a known-good monitor.

No picture on monitor.

Check brightness and contrast controls. Check that video cable from genlock is connected between video out of the genlock and video in of the monitor. If screen is blue, check cable between LDP and genlock.

No video text displayed.

Check to see that the genlock module is properly connected to the twenty three pin 'D' connector on the main electronics board. The main computer board may also be at fault. Reseat the socketed ICs on the main computer board.

Main electronics board does not turn on.

Check that the power supply is switched ON, and that the game & power supply power cords are both plugged in. Check the game AC fuse for being blown. Check power at the outlet with an AC voltmeter. Check the power supply output plug with a DC voltmeter.

START push-button switch does not respond.

Check that the nine (9) pin 'D' type connector for the console switches is plugged into the J100 nine (9) pin connector on the TAOS (opto-amplifier) board. Check that the nine (9) pin 'D' type jumper cable is connected between the main electronics board "CONSOLE" connector and the TAOS board at J109. Check continuity of the console switch cable with an ohm meter. Check continuity of the jumper cable with an ohm meter. Check for switch closure with an ohm meter. Check that the cable is properly connected to the start push-button (I.E. Common and Normally Open contacts). Check that there are credits to play on the machine.

Service push-button switch does not respond.

Check that the nine (9) pin 'D' type connector for the console controls is plugged into the J100 nine (9) pin connector on the TAOS (opto-amplifier) board. Check that the nine (9) pin 'D' type jumper cable is connected between the main electronics board "CONSOLE" connector and the TAOS board at J109. Check continuity of the console switch cable with an ohm meter. Check continuity of the jumper cable with an ohm meter. Check for switch closure with an ohm meter. Check that the cable is properly connected to the service push-button (I.E. Common and Normally Open contacts).

Coin mechanism does not respond.

Check that the nine (9) pin 'D' type connector for the console controls is plugged into the J100 nine (9) pin connector on the TAOS (opto-amplifier) board. Check that the nine (9) pin 'D' type jumper cable is connected between the main electronics board "CONSOLE" connector and the TAOS board at J109. Check continuity of the console switch cable with an ohm meter. Check continuity of the jumper cable with an ohm meter. Check for switch closure with an ohm meter. Check that the cable is properly connected to the coin mechanism switch (i.e. Common & Normally Open contacts).

AMERICAN LASER GAMES

Laser disk player does not turn on.

Check that the power cord is plugged in. Check that the front panel power switch is depressed. Check the fuse for being blown. Check power at the outlet with an AC voltmeter.

No laser disk video.

Check that the laser disk is inserted into the machine properly, the shiny side must face down. Check that BNC to RCA cable is properly connected between the laser disk player video output and the genlock video input. If this is not the problem, here is a simple test to determine in what area the problem lies. Disconnect the serial cable from the back of the laser disk player. Turn the power to the laser disk player off and then on again. A female RCA to female RCA adapter may be used to temporarily jump the laser disk video around the genlock. Connect video from the laser disk player to one side of the female adapter, connect the cable from the monitor to the other side of the female adapter. If you now have video the genlock or main board is at fault. If you still don't have video connect the video output from the laser disk player to a known good monitor. If you still don't have video then the laser disk player is bad, if you do have video then the internal monitor is likely to be at fault.

No laser disk sound

Check that the RCA cables are connected to the laser disk player right and left audio outputs. Check that the other ends of the RCA cables are connected to J123 (left) & J123 (right) audio inputs on the TAOS (opto-amplifier) board. Check the remote volume control near the SERVICE switch and the volume potentiometers R8 & R7 on the TAOS (opto-amplifier) board. Finally, check the audio outputs of the laser disk player with an oscilloscope or by connecting the laser disk audio outputs to a known good audio amplifier/speaker system.

Laser disk player not responding.

Check that the serial cable is properly connected between the laser disk player and the electronics main board. Check the video disk for scratches and excessive dirt build up. Clean if necessary. Check the laser optics in the laser disk player for dirt or dust build up. Clean if necessary. Align optics at 5,000 operational hours & replace at 10,000 operational hrs.

Laser disk player not on external C.P.U. control.

Check to see if the serial cable is properly connected between the laser disk player and the electronics main board. The cable may be faulty so check serial cable continuity with an ohm meter to insure that the wiring is in compliance with our diagram.

Screen says ' LASER DISK OUT OF FOCUS '

The serial cable between the laser disk player and the main electronics board is broken or not connected. The laser disk player may also be at fault. Test the serial cable for opens and shorts with an ohm meter, refer to the serial cable wiring diagram for the wiring list. Try turning the laser disk player off and then on to reset the laser disk player internal microprocessor.

White images or text outlined by red,green, or blue.

Check the convergence controls on the monitor and adjust if necessary.

Too few or many credits per game.

Check and adjust COINS PER TICK or CREDITS PER TICK or CONTINUE COINS in the service mode.

AMERICAN LASER GAMES

The gun shoots in GUN AIMING mode but not in normal game play.

The RELOAD mercury switch inside the gun has been installed upside down or the RELOAD wire has shorted to GND. The condition of the mercury switch is ignored in GUN AIMING mode but is monitored during game play.

Screen flashes continuously as is trigger is being pulled.

Check if the gun TRIGGER signal is shorted to ground...perhaps on the backside of the gun shot board, elsewhere inside the gun, at the gun cable 9-pin "D" connector, anywhere along the gun cabling, or possibly between TAOS J-108 and the main computer board CN-2 connector.

Shot "spotch" appears at the same spot no matter where the gun is aimed.

The "shot sense" output signal from the gun shot board may be shorting to ground ... or the LM-311 IC on the gun shot board may be "fried." Inspect the backside of the gun shot board, elsewhere inside the gun, at the gun cable 9-pin "D" connector, anywhere along the gun cabling, or possibly between TAOS J-108 and the main computer board CN-2 connector.

Both English & Japanese soundtracks are heard.

A dual language disk is installed, but the RAM/ROM version does not support a dual language disk. The solution is to get a RAM/ROM version which supports dual language disks. Call A.L.G. for version information.

Ticket Dispenser won't operate

Check that tickets are present and the LOW TICKET switch is open (LOW TICKET LED is OFF). Check that +12VDC is present at the ticket machine connector, P112 pin 5. If it is absent, suspect the LM340-T12 voltage regulator mounted near the TAOS board but screwed to the wood floor of the equipment tray. Check that P112 pin 6 is at ground. Check that the signal at P112 pin 3 pulses low for at least 50 milliseconds when a ticket is expected to be dispensed (see TICKETS in the SERVICE menu). If any of the above tests fail, then the TAOS opto-amplifier board is likely at fault. If partial tickets are being dispensed, check the alignment of the photodetector in the ticket dispenser mechanism. If all the above checks out OK, then the ticket dispenser mechanism is most likely at fault.

Loses accounting information.

Battery built into the RAM chip on the RAM/ROM board is low. RAM/ROM board is not securely connected to the main electronics board. Defective RAM/ROM board.

Video jumps or is scratchy.

Check the video disk for scratches and excessive dirt build up. Clean if necessary. Check the laser optics in the laser disk player for dirt or dust build up. Clean if necessary.

Screen flashes different colors and does not continue.

Check to see if the laser disk player is turned on and connected to the electronics main board serial port. Check to see that the serial port baud rate on the laser disk player is set correctly (refer to diagram for proper laser disk switch settings).

CRIME PATROL SERVICE MENUS

SERVICE MENUS provide built-in coin accounting, operator adjustment of the cost to play the game, gun calibration, and various hardware tests. Select the SERVICE mode by pushing the SERVICE button located behind the coin acceptor panel. You will then see the screens described below.

SERVICE MENU

- (1) COIN INFO
 - (2) GAME SETTINGS
 - (3) GUN AIMING
 - (4) HARDWARE TESTS
- NIGHTCLUB: ADULT/FAMILY
DONE
PRESS START: SELECT

This is the first screen you'll see after pressing the SERVICE button. The numbers in parentheses are not displayed, but are shown here to direct you to a selected sub-menu.

COIN INFO provides money receipts information.

GAME SETTINGS allows you to set up the cost to play the game, the cost to continue the game, and the level of difficulty. TICKET DISPENSER operation can be enabled & adjusted here also.

GUN AIMING allows you to calibrate where the gun shots are detected versus where you aim.

HARDWARE TESTS include color-bar and convergence screens, an audio test, switch tests (SERVICE switch, left & rt. COINS, left & rt. STARTs, and left & rt. TRIGGER switches), a test of the RAM & ROMs on the RAM/ROM card, and a laser player "exercise" test and a laser disk "surface scan" test.

NIGHTCLUB determines whether dancers will be seen or bypassed in attract mode and at the nightclub scene.

Select DONE when finished and ready to return to normal game-playing mode.

(1) LEFT COINS: 0200
RIGHT COINS: 0400
TOTAL GAMES: 0075
AVG. TIME: 02:16
MOST TIME: 09:25
PRESS START: CLEAR

This screen provides information about money taken in by the game. This first screen shows information since you last CLEARED this screen... by pressing the START button. **This information can be erased ... see the next screen for permanent coin information.**

You MUST press the SERVICE button to exit this screen. You will then see a screen which lists **permanent** TOTALs information.

TOTAL L COINS: 00418
TOTAL R COINS: 00213
GAMES TO DATE: 00119
CONTINUE GAMES: 00275
TOTAL WINS: 00015
AVG. CR TO WIN: 00012
PRESS SERVICE: DONE

This screen gives **permanent** coin information so separate mechanical coin counters are not necessary.

The top four numbers cannot be reset!

However, if the RAM/ROM card is replaced, the information stored on the RAM/ROM card will be different. Since these numbers can't be adjusted, you should WRITE DOWN these numbers before replacing or updating a RAM/ROM card.

TOTAL WINS and AVG. CR TO WIN can and are reset when the previous COIN INFO screen is cleared using the START switch.

Press the SERVICE switch to return to the top-level service menu.

(2)

LEFT SLOT INFO

COINS PER TICK: 4
CONTINUE COINS: 2
CREDITS PER TICK: 3
LEVEL: NORMAL
DONE
PRESS START: CHANGE

RIGHT SLOT INFO

COINS PER TICK: 4
CONTINUE COINS: 2
CREDITS PER TICK: 1
PLAYERS: 1 -or- 2
DONE
PRESS START: CHANGE

OTHER INFO

LIVES PER PLAY: 1..6
LIVES PER CONT: 1..6
DUAL LANGUAGE YES/NO
ATTRACT AUDIO YES/1..9
TICKETS
DONE
PRESS START: CHANGE

COINS PER TICK: 0..8 are valid: 0 = games are FREE

CONTINUE COINS: 0..8 valid: 0=FREE game continuation

CREDITS PER TICK: 1..8 are valid:

With this setup the player gets 3 plays (CREDITS PER TICK) per dollar (COINS PER TICK) but continuing only costs 50 cents. (Assuming 25 cent coins). It is likely that you'll want to set the CREDITS PER TICK value to 1 so that you get 1 game play for 4 coins (in this case) or for whatever number you have set COINS PER TICK to.

Valid settings for **LEVEL** are EASY/NORMAL/HARD. HARD means that you'll have more targets to shoot in some scenes before advancing to the next scene.

Selecting **DONE** will show you the RIGHT SLOT INFO screen.

Same as LEFT SLOT INFO except the LEVEL of difficulty appears only on the LEFT SLOT INFO screen. Right & left slot setup can be different if desired.

PLAYERS defines whether 1 or 2 players are recognized. When "2 players" is selected, then three "LIVES PER PLAY" is the maximum. Up to seven LIVES PER PLAY are allowed in "1 player" mode.

Selecting **DONE** moves to a OTHER INFO menu.

LIVES PER PLAY determines how many times the player can get shot or how many "innocents" the player may shoot before another credit must be used. LIVES PER CONTINUE is the same as LIVES PER PLAY except it applies to a continued game.

You may select YES for **DUAL LANGUAGE** if you have a dual language disk in the laser disk player. If YES is selected, then the player will have a choice of languages when the game begins. Select the appropriate language by shooting at a flag which represents the language you wish.

Important Note: If you do NOT have a dual language disk, then selecting YES for DUAL LANGUAGE will cause the screen to go blank when START is pushed to begin a game.

The **ATTRACT AUDIO** selection determines how often the laser disk audio will be heard during the "attract mode". If you select YES, the audio will be heard every time through the attract mode. Selecting 1 means the audio will be silent on alternate times through. Selecting 5 means the audio will be silent 5 out of 6 iterations. If dual language is selected, the attract mode will output the Japanese soundtrack.

Selecting **TICKETS** will show a TICKET INFO screen which allows enabling/disabling of the ticket dispenser and adjustment of ticket dispenser operation.

Selecting **DONE** returns to the top-level SERVICE MENU.

TICKET INFO

AVG. TICKETS: 00012
MOST TICKETS: 00025
TOTAL TICKETS: 00327
CLEAR TOTALS
DONE

The TICKET INFO screen provides historical information about ticket dispenser operation.

AVG. TICKETS provides the average number of tickets given out per game since TICKET INFO was last cleared.

MOST TICKETS and TOTAL TICKETS provide the highest number of tickets on any game and the total sum of tickets given out since TICKET INFO was last cleared.

Press the START button while CLEAR TOTALS is flashing to clear this ticket information.

Select DONE to move to the TICKET CONTROL menu (below).

TICKET CONTROL

TICKETS ACTIVE: YES/NO
ADJUST TICKETS
FEED A TICKET
DONE
PRESS START: CHANGE

The TICKET CONTROL screen provides for enabling or disabling ticket dispenser operation, adjusting several parameters which affect ticket payout, and running the ticket dispenser motor to help with loading tickets & testing ticket dispenser operation.

Setting TICKETS ACTIVE to YES enables ticket dispenser operation. Selecting NO disables ticket dispenser operation entirely...other than FEED A TICKET .

Selecting ADJUST TICKETS shows the TICKET PAYOUT menu where details of ticket dispenser payout may be adjusted.

Selecting FEED A TICKET causes the ticket dispenser to eject ONE ticket...or run until a hole between tickets is detected or approximately 1 second elapses.

Selecting DONE returns to the OTHER INFO screen.

TICKET PAYOUT

FIRST TICKETS: 0...9
SCORE EVERY
0250 0250
2000 0500
DONE
PRESS START: CHANGE

Tickets are dispensed as they are earned, not all at once.

The TICKET PAYOUT screen has the following features:

FIRST TICKETS determines how many tickets a player gets for each credit used. FIRST TICKETS has nothing to do with game scoring...only with credits used.

The SCORE and EVERY parameters determine when a player earns another ticket. For the example shown, a player will earn one ticket for every 250 points he gets above a score of 250. After the player reaches a score of 1000, it will take 500 points to earn each additional ticket. Both SCORE and EVERY are adjustable. Set them as you feel is appropriate.

Selecting DONE returns to the OTHER INFO screen.

(3)

O

**TO CALIBRATE GUN:
HOLD START. AIM AT
THE SPOT AND SHOOT**

Older guns may need **photodetector realignment** occasionally due to player abuse of the gun. (Newer guns with a plastic tube in the gun barrel do not require realignment.) The photodetector is located on the small PC board inside the gun. Adjust the photodetector position by bending its leads slightly until it appears centered when viewed through the lens of an assembled gun. Also check that **component leads** on the back side of the gun shot board are **not shorting** to the metal gun case. **Check the 4 wire connector** to the gun shot PC board for good connections also.

(4)

HARDWARE TESTS

(COLOR BARS)

(AUDIO TEST)

This menu provides for **calibrating where the gun shoots**. Aim at the target while holding the trigger in...then **tap** either START button for a moment.

While the START button is pressed and the gun is triggered, the main computer board defines the spot where the gun is pointing as the center of the screen. When the START button is NOT pressed, you will see a "splotch" for each trigger pull. After calibration, this "splotch" should overlay the calibration target ... within your ability to accurately point the gun at the calibration target.

*Verify gun performance by shooting around the screen borders. **Balance the gun calibration side-to-side & top-to-bottom.*** You should be able to shoot as far left as you can shoot to the right and as far up as down. If not, recalibrate until you can. Calibration should be done at normal playing distance.

Be sure the gun lens is clean, free of smudges or dust, and the lens is not chipped. The screen should be bright, but not washed out, and the game should NOT be located in bright sunlight or direct fluorescent lights.

If you're having trouble shooting at the extreme left edge, try calibrating SLIGHTLY to the right edge of the calibration target. Similarly, to be able to shoot lower on the screen, try calibrating SLIGHTLY above the calibration target.

Press the SERVICE button to exit this calibration screen.

You will then see a **TARGET ALIGNMENT** screen which provides a way to align the "hit zones" with the live-action video from the LDP. Use the two start buttons as indicated to position the squares over the badges.

The first **HARDWARE TEST** is a **COLOR BAR** screen. This screen is useful for adjusting monitor colors. The color bars are stored on the laser disk and displayed during this test.

A 2nd screen shows a **convergence grid** which is useful for examining and adjusting monitor convergence.

The 3rd screen involves a test of the main computer board audio. (To test laser disk audio, connect the laser disk player to an audio amplifier, or directly to the audio input of the 50" monitor (if applicable), or view the signals on an oscilloscope). The **audio test** shows **AUDIO-0/AUDIO-1/AUDIO-2/AUDIO-3** on the screen. Only one audio output from the main computer board is used even though it has two audio outputs. Thus, if the CN4 audio connector on the main computer board is connected to the TAOS (audio amplifier) board, you will hear the test sound **ONLY** when **AUDIO 0** and **AUDIO 3** are displayed. This is normal. If the CN3 audio jack on the main computer board is used, you will hear sounds only for **AUDIO 1** and **AUDIO 2**.

Press the SERVICE switch to exit to a SWITCH TEST screen.

SWITCH TEST

LEFT COIN	OPEN/CLOSED	
RIGHT COIN	OPEN/CLOSED	
SERVICE	OPEN/CLOSED	
STARTS	0/1	0/1
HOLSTERS	0/1	0/1
TRIGGERS	0/1	0/1

TESTING ROMS

The third screen of the **HARDWARE TESTS** checks the ability of the **main computer board** to read various switches. As you close each switch, you should see the screen message for that switch change from **OPEN** to **CLOSED** (or 0 to 1) when the main computer board recognizes the closure.

Note that **screen update takes about 1 second** so **HOLD each switch closed** until you see the screen message has changed.

Operate the **SERVICE** button last, because it clears this screen and moves to the next test.

The **STARTS** message tests the front panel **START** switches. A "0" indicates an open switch and a "1" indicates a closed switch. The left column is for the left **START** switch.

The **LEFT COIN** and **RIGHT COIN** message tests the coin acceptors. If present, a dollar bill acceptor should register on the **RIGHT COIN** input.

The **HOLSTERS** message tests the gun mercury switches for the **RELOAD** function. The screen should show **HOLSTER** as "1" (closed) when the gun is pointed down and "0" (open) when the gun barrel is horizontal.

The **TRIGGERS** message shows that each trigger switch is working and being recognized by the main computer board. A "0" indicates an open trigger switch and a "1" indicates a closed trigger switch.

This **ROM TEST** screen appears briefly during the main computer board's verification of the **RAM & EPROMs** on the **RAM/ROM** card. If the contents of the **RAM & EPROMs** are valid, the test program returns to the top-level service menu. If an error is detected, the test program halts at this screen and displays the error message **ROM CHECKSUM FAILURE**. If you see this message, first check that the **IC** chips on the **RAM/ROM** board are properly seated and that the **RAM/ROM** board itself is properly seated on the main computer board.

If **RAM** contents have unexpectedly changed, the message "**RAM CHECKSUM ERROR...RESETTING ADJUSTS**" will be displayed. This message means that the main computer has assigned default values for all adjustable parameters and has reset all coin information and game statistics. This may occur due to **RAM** battery failure (5-yr **RAM**), as a result of installing updated **EPROMs**, or when a **RAM/ROM** card is installed for the first time.

OPERATION	FRAME #
DISK SIZE:	53940
TEST NUM:	00123
(SEARCH START):	000
PRESS START:	CLEAR
FAILURES:	00000

This screen shows information from a "disk exerciser" software routine. Its purpose is to aid in evaluating questionable laser disk players.

The **DISK SIZE** value is the highest frame number that could be read by the player from the disk during a search algorithm. The **TEST NUMBER** represents the number of times through a sequence of operations. The text in the **oval-shaped box** (SEARCH START) is the operation which the "disk exerciser" software is currently commanding the LDP to perform. The 3-digit number to the right is the number of failures logged for that particular test. Tests commanded are:

SEARCH START	PAUSE
SEARCH END	FORWARD STEP
PLAY	REVERSE STEP
REVERSE PLAY	SEARCH
FAST PLAY	PAUSE
FAST REVERSE	TESTS COMPLETE

The text in the **lower square box** appears briefly at the end of each cycle of tests. Press either START switch to clear failure counts. The bottom **FAILURES** count line is a composite count of failures of all types of commanded LDP operations.

Press the **SERVICE** switch to exit to a **SURFACE SCAN** test screen.

STILL	FRAME #
SURFACE SCAN	
FRAME:	00379
FAILURES:	00000
PRESS SERVICE:	DONE

The **SURFACE SCAN** screen shows the progress and results of software which commands the laser player to search to each and every frame number on the laser disk. This test is intended to **identify any unreadable or inaccessible frames** on the disk.

This test requires about 4 1/2 hours to completely scan the disk, but it may be interrupted any time by pressing the **SERVICE** switch.

If the "disk exercise" or surface scan test report errors, likely causes include:

- Dust on the disk and/or the player lenses...clean per ALG service note (call for FAX of service note).
- Fingerprints or scratches on the disk...use Novus #1
- Sluggish/sticky LDP head positioning mechanism (clean/lubricate shaft per Sony recommendations)
- Out-of-alignment laser player optics ... send LDP to qualified repair center.
- Warped or otherwise damaged disk

Pressing the **SERVICE** switch returns to the top-level **SERVICE MENU**.

MAD DOG II-THE LOST GOLD SERVICE MENUS

SERVICE MENUS provide built-in coin accounting, operator adjustment of the cost to play the game, gun calibration, and various hardware tests. Select the SERVICE mode by pushing the SERVICE button located behind the coin acceptor panel. You will then see the screens described below.

SERVICE MENU

- (1) COIN INFO
 - (2) GAME SETTINGS
 - (3) GUN AIMING
 - (4) HARDWARE TESTS
- DONE
PRESS START: SELECT

This is the first screen you'll see after pressing the SERVICE button. The numbers in parentheses are not displayed, but are shown here to direct you to a selected sub-menu.

COIN INFO provides money receipts information.

GAME SETTINGS allows you to set up the cost to play the game, the cost to continue the game, and the level of difficulty. TICKET DISPENSER operation can be enabled & adjusted here also.

GUN AIMING allows you to calibrate where the gun shots are detected versus where you aim.

HARDWARE TESTS include color-bar and convergence screens, an audio test, switch tests (SERVICE switch, left & rt. COINs, left & rt. STARTs, and left & rt. TRIGGER switches), a test of the RAM & ROMs on the RAM/ROM card, and, on versions 2.0 and up a laser player "exercise" test & a laser disk "surface scan" test.

Select DONE when finished and ready to return to normal game-playing mode.

(1) LEFT COINS: 0200
RIGHT COINS: 0400
TOTAL GAMES: 0075
AVG. TIME: 02:16
MOST TIME: 09:25
PRESS START: CLEAR

This screen provides **information about money taken in** by the game. This first screen shows information since you last CLEARED this screen... by pressing the START button. **This information can be erased ... see the next screen for permanent coin information.**

You MUST press the SERVICE button to exit this screen. You will then see a screen which lists **permanent** TOTALS information.

TOTAL L COINS: 00418
TOTAL R COINS: 00213
GAMES TO DATE: 00119
CONTINUE GAMES: 00275
TOTAL WINS: 00015
AVG. CR TO WIN: 00012
PRESS SERVICE: DONE

This screen gives **permanent coin information** so separate mechanical coin counters are not necessary.

The top four numbers cannot be reset!

However, if the RAM/ROM card is replaced, the information stored on the RAM/ROM card will be different. Since these numbers can't be adjusted, you should WRITE DOWN these numbers before replacing or updating a RAM/ROM card.

TOTAL WINS and AVG. CR TO WIN can and are reset when the previous COIN INFO screen is cleared using the START switch.

Press the SERVICE switch to return to the top-level service menu.

(2)

LEFT SLOT INFO

COINS PER TICK: 4
CONTINUE COINS: 2
CREDITS PER TICK: 3
LEVEL: NORMAL
DONE
PRESS START: CHANGE

RIGHT SLOT INFO

COINS PER TICK: 4
CONTINUE COINS: 2
CREDITS PER TICK: 1
PLAYERS: 1 -or- 2
DONE
PRESS START: CHANGE

OTHER INFO

LIVES PER PLAY: 1..3/1..7
LIVES PER CONT: 1..3/1..7
DUAL LANGUAGE YES/NO
ATTRACT AUDIO YES/1..9
TICKETS
DONE
PRESS START: CHANGE

COINS PER TICK: 0...8 are valid: 0 = games are FREE

CONTINUE COINS: 0...8 valid: 0=FREE game continuation

CREDITS PER TICK: 1...8 are valid:

With this setup the player gets 3 plays (CREDITS PER TICK) per dollar (COINS PER TICK) but continuing only costs 50 cents. (Assuming 25 cent coins). It is likely that you'll want to set the CREDITS PER TICK value to 1 so that you get 1 game play for 4 coins (in this case) or for whatever number you have set COINS PER TICK to.

Valid settings for **LEVEL** are EASY/NORMAL/HARD. HARD means that you'll have more targets to shoot in some scenes before advancing to the next scene.

Selecting **DONE** will show you the RIGHT SLOT INFO screen.

Same as LEFT SLOT INFO except the LEVEL of difficulty appears only on the LEFT SLOT INFO screen. Right & left slot setup can be different if desired.

PLAYERS defines whether 1 or 2 players are recognized. When "2 players" is selected, then three "LIVES PER PLAY" is the maximum. Up to seven LIVES PER PLAY are allowed in "1 player" mode.

Selecting **DONE** moves to a OTHER INFO menu.

LIVES PER PLAY determines how many times the player can get shot or how many "innocents" the player may shoot before another credit must be used. When "2 players" is selected, then three "LIVES PER PLAY" is the maximum. Up to seven LIVES PER PLAY are allowed in "1 player" mode. **LIVES PER CONTINUE** is the same as LIVES PER PLAY except it applies to a continued game.

You may select YES for **DUAL LANGUAGE** if you have a dual language disk in the laser disk player. If YES is selected, then the player will have a choice of languages when the game begins. Select the appropriate language by shooting at a flag which represents the language you wish.

Important Note: If you do NOT have a dual language disk, then selecting YES for DUAL LANGUAGE will cause the screen to go blank when START is pushed to begin a game.

The **ATTRACT AUDIO** selection determines how often the laser disk audio will be heard during the "attract mode". If you select YES, the audio will be heard every time through the attract mode. Selecting 1 means the audio will be silent on alternate times through. Selecting 5 means the audio will be silent 5 out of 6 iterations. If dual language is selected, the attract mode will output the Japanese soundtrack.

Selecting **TICKETS** will show a TICKET INFO screen which allows enabling/disabling of the ticket dispenser and adjustment of ticket dispenser operation.

Selecting **DONE** returns to the top-level SERVICE MENU.

TICKET INFO

AVG. TICKETS: 00012
MOST TICKETS: 00025
TOTAL TICKETS: 00327
CLEAR TOTALS
DONE

The TICKET INFO screen provides historical information about ticket dispenser operation.

AVG. TICKETS provides the average number of tickets given out per game since **TICKET INFO** was last cleared.

MOST TICKETS and **TOTAL TICKETS** provide the highest number of tickets on any game and the total sum of tickets given out since **TICKET INFO** was last cleared.

Press the **START** button while **CLEAR TOTALS** is flashing to clear this ticket information.

Select **DONE** to move to the **TICKET CONTROL** menu (below).

TICKET CONTROL

TICKETS ACTIVE: YES/NO
ADJUST TICKETS
FEED A TICKET
DONE
PRESS START: CHANGE

The **TICKET CONTROL** screen provides for enabling or disabling ticket dispenser operation, adjusting several parameters which affect ticket payout, and running the ticket dispenser motor to help with loading tickets & testing ticket dispenser operation.

Setting **TICKETS ACTIVE** to **YES** enables ticket dispenser operation in 1-player mode. *Ticket operation is currently not available in 2-player mode.* Selecting **NO** disables ticket dispenser operation entirely...other than **FEED A TICKET**.

Selecting **ADJUST TICKETS** shows the **TICKET PAYOUT** menu where details of ticket dispenser payout may be adjusted.

Selecting **FEED A TICKET** causes the ticket dispenser to eject **ONE** ticket...or run until a hole between tickets is detected or approximately 1 second elapses.

Selecting **DONE** returns to the **OTHER INFO** screen.

TICKET PAYOUT

FIRST TICKETS: 0...9
SCORE **EVERY**
0250 0250
1000 0500
DONE
PRESS START: CHANGE

Tickets are dispensed as they are earned, not all at once.

The **TICKET PAYOUT** screen has the following features:

FIRST TICKETS determines how many tickets a player gets for each credit used. **FIRST TICKETS** has nothing to do with game scoring...only with credits used.

The **SCORE** and **EVERY** parameters determine when a player earns another ticket. For the example shown, a player will earn one ticket for every 250 points he gets above a score of 250. After the player reaches a score of 1000, it will take 500 points to earn each additional ticket. Both **SCORE** and **EVERY** are adjustable. Set them as you feel is appropriate.

Selecting **DONE** returns to the **OTHER INFO** screen.

(3)

O

**TO CALIBRATE GUN:
HOLD START. AIM AT
THE SPOT AND SHOOT**

Older guns may need **photodetector realignment** occasionally due to player abuse of the gun. (Newer guns with a plastic tube in the gun barrel do not require realignment.) The photodetector is located on the small PC board inside the gun. Adjust the photodetector position by bending its leads slightly until it appears centered when viewed through the lens of an assembled gun. Also check that **component leads** on the back side of the gun shot board are **not shorting** to the metal gun case. **Check the 4 wire connector** to the gun shot PC board for good connections also.

(4)

HARDWARE TESTS

(COLOR BARS)

(AUDIO TEST)

This menu provides for **calibrating where the gun shoots**. Aim at the target while holding the trigger in...then **tap** either START button for a moment.

While the START button is pressed and the gun is triggered, the main computer board defines the spot where the gun is pointing as the center of the screen. When the START button is **NOT** pressed, you will see a "splotch" for each trigger pull. After calibration, this "splotch" should overlay the calibration target ... within your ability to accurately point the gun at the calibration target.

Verify gun performance by shooting around the screen borders.
Balance the gun calibration side-to-side & top-to-bottom. You should be able to shoot as far left as you can shoot to the right and as far up as down. If not, recalibrate until you can. Calibration should be done at normal playing distance.

Be sure the gun lens is clean, free of smudges or dust, and the lens is not chipped. The screen should be bright, but not washed out, and the game should **NOT** be located in bright sunlight or direct fluorescent lights.

If you're having trouble shooting at the extreme left edge, try calibrating **SLIGHTLY** to the right edge of the calibration target. Similarly, to be able to shoot lower on the screen, try calibrating **SLIGHTLY** above the calibration target.

Press the SERVICE button to exit this calibration screen.

The first **HARDWARE TEST** is a **COLOR BAR** screen. This screen is useful for adjusting monitor colors. The color bars are stored on the laser disk and displayed during this test.

A 2nd screen shows a convergence grid which is useful for examining and adjusting monitor convergence.

The 3rd screen involves a test of the main computer board audio. (To test laser disk audio, connect the laser disk player to an audio amplifier, or directly to the audio input of the 50" monitor (if applicable), or view the signals on an oscilloscope). The **audio test** shows **AUDIO-0/AUDIO-1/AUDIO-2/AUDIO-3** on the screen. Only one audio output from the main computer board is used even though it has two audio outputs. Thus, if the CN4 audio connector on the main computer board is connected to the TAOS (audio amplifier) board, you will hear the test sound **ONLY** when **AUDIO 0** and **AUDIO 3** are displayed. This is normal. If the CN3 audio jack on the main computer board is used, you will hear sounds only for **AUDIO 1** and **AUDIO 2**.

Press the SERVICE switch to exit to a SWITCH TEST screen.

SWITCH TEST

LEFT COIN	OPEN/CLOSED
RIGHT COIN	OPEN/CLOSED
SERVICE	OPEN/CLOSED
STARTS	0/1 0/1
HOLSTERS	0/1 0/1
TRIGGERS	0/1 0/1

TESTING ROMS

The third screen of the **HARDWARE TESTS** checks the ability of the **main computer board to read various switches**. As you close each switch, you should see the screen message for that switch change from **OPEN** to **CLOSED** (or 0 to 1) when the main computer board recognizes the closure.

Note that **screen update takes about 1 second** so HOLD each switch closed until you see the screen message has changed.

Operate the **SERVICE** button last, because it clears this screen and moves to the next test.

The **STARTS** message tests the front panel **START** switches. A "0" indicates an open switch and a "1" indicates a closed switch. The left column is for the left **START** switch.

The **LEFT COIN** and **RIGHT COIN** message tests the coin acceptors. If present, a dollar bill acceptor should register on the **RIGHT COIN** input.

The **HOLSTERS** message tests the gun mercury switches for the **RELOAD** function. The screen should show **HOLSTER** as "1" (closed) when the gun is pointed down and "0" (open) when the gun barrel is horizontal.

The **TRIGGERS** message shows that each trigger switch is working and being recognized by the main computer board. A "0" indicates an open trigger switch and a "1" indicates a closed trigger switch.

This **ROM TEST** screen appears briefly during the main computer board's verification of the **RAM & EPROMs** on the **RAM/ROM** card. If the contents of the **RAM & EPROMs** are valid, the test program returns to the top-level service menu. If an error is detected, the test program halts at this screen and displays the error message **ROM CHECKSUM FAILURE**. If you see this message, first check that the IC chips on the **RAM/ROM** board are properly seated and that the **RAM/ROM** board itself is properly seated on the main computer board.

If **RAM** contents have unexpectedly changed, the message "**RAM CHECKSUM ERROR...RESETTING ADJUSTS**" will be displayed. This message means that the main computer has assigned default values for all adjustable parameters and has reset all coin information and game statistics. This may occur due to **RAM** battery failure (5-yr **RAM**), as a result of installing updated **EPROMs**, or when a **RAM/ROM** card is installed for the first time.

OPERATION	FRAME #
DISK SIZE:	54000
TEST NUM:	00123
(SEARCH START):	000
PRESS START:	CLEAR
FAILURES:	00000

This screen shows information from a "disk exerciser" software routine in MDII versions 2.02 and up. Its purpose is to aid in evaluating questionable laser disk players.

The **DISK SIZE** value is the highest frame number that could be read by the player from the disk during a search algorithm. The **TEST NUMBER** represents the number of times through a sequence of operations. The text in the oval-shaped box (SEARCH START) is the operation which the "disk exerciser" software is currently commanding the LDP to perform. The 3-digit number to the right is the number of failures logged for that particular test. Tests commanded are:

SEARCH START	PAUSE
SEARCH END	FORWARD STEP
PLAY	REVERSE STEP
REVERSE PLAY	SEARCH
FAST PLAY	PAUSE
FAST REVERSE	TESTS COMPLETE

The text in the lower square box appears briefly at the end of each cycle of tests. Press either START switch to clear failure counts. The bottom **FAILURES** count line is a composite count of failures of all types of commanded LDP operations.

Press the SERVICE switch to exit to a SURFACE SCAN test screen.

The **SURFACE SCAN** screen shows the progress and results of software which commands the laser player to search to each and every frame number on the laser disk. This test is intended to **identify any unreadable or inaccessible frames** on the disk.

This test requires about 4 1/2 hours to completely scan the disk, but it may be interrupted any time by pressing the SERVICE switch.

If the "disk exercise" or surface scan test report errors, likely causes include:

- Dust on the disk and/or the player lenses
- Fingerprints or scratches on the disk
- Sluggish/sticky LDP head positioning mechanism (clean/lubricate shaft per Sony recommendations)
- Out-of-alignment laser player optics
- Warped or otherwise damaged disk

Pressing the SERVICE switch returns to the top-level SERVICE MENU.

STILL	FRAME #
SURFACE SCAN	
FRAME:	00379
FAILURES:	00000
PRESS SERVICE:	DONE

MAD DOG McCREE SERVICE MENUS

The Mad Dog McCree game has SERVICE MENUS which provide built-in coin accounting, operator adjustment of the cost to play the game, gun calibration, and various hardware tests. Select the SERVICE mode by pushing the SERVICE button located behind the coin acceptor panel. You will then see the screens described below.

SERVICE MENU

- (1) COIN INFO
- (2) GAME SETTINGS
- (3) GUN AIMING
- (4) HARDWARE TESTS

DONE

PRESS START: SELECT

This is the first screen you'll see after pressing the SERVICE button. The numbers in parentheses are not displayed, but are shown here to direct you to a selected sub-menu.

COIN INFO provides money receipts information.

GAME SETTINGS allows you to set up the cost to play the game, the cost to continue the game, and, on later software versions, the level of difficulty. TICKET DISPENSER operation can be enabled & adjusted here also.

GUN AIMING allows you to calibrate where the gun shots are detected versus where you aim.

HARDWARE TESTS include a color-bar screen, an audio test, switch tests (SERVICE switch, left & right COIN, START, and TRIGGER switches), and a test of the ROMs on the RAM/ROM card.

Select DONE when finished and ready to return to normal game-playing mode.

(1) LEFT COINS:	0200
RIGHT COINS:	0400
TOTAL GAMES:	0075
AVG. TIME:	02:16
MOST TIME:	09:25
PRESS START: CLEAR	

This screen provides **information about money taken in** by the game. This first screen shows information since you last CLEARED this screen by pressing the START button. **This information can be erased ... see the next screen for permanent coin information**

You MUST press the SERVICE button to exit this screen. You will then see a screen which lists **permanent** TOTALS information.

TOTAL L COINS:	00418
TOTAL R COINS:	00213
GAMES TO DATE:	00119
CONTINUE GAMES:	00275
PRESS SERVICE: DONE	

This screen gives **permanent coin information** so separate mechanical coin counters are not necessary.

These numbers cannot be reset!

However, if the RAM/ROM card is replaced or update EPROMs are installed, the information stored on the RAM/ROM card will be different. Since these numbers can't be adjusted, you should WRITE DOWN these numbers before replacing or updating the RAM/ROM card.

Press the SERVICE switch to return to the top-level service menu.

(2)

LEFT SLOT INFO

COINS PER TICK: 4
CONTINUE COINS: 2
CREDITS PER TICK: 3
LEVEL: NORMAL
DONE
PRESS START: CHANGE

RIGHT SLOT INFO

COINS PER TICK: 4
CONTINUE COINS: 2
CREDITS PER TICK: 1
DONE
PRESS START: CHANGE

OTHER INFO

DUAL LANGUAGE YES/NO
ATTRACT AUDIO YES/1...9
TICKETS
DONE
PRESS START: CHANGE

COINS PER TICK: 0...8 are valid: 0 = games are FREE

CONTINUE COINS: 0...8 valid: 0=FREE game continuation

CREDITS PER TICK: 1...8 are valid:

With this setup the player gets 3 plays (CREDITS PER TICK) per dollar (COINS PER TICK) but continuing only costs 50 cents. (Assuming 25 cent coins). It is likely that you'll want to set the CREDITS PER TICK value to 1 so that you get 1 game play for 4 coins (in this case) or for whatever number you have set COINS PER TICK to.

Valid settings for **LEVEL** are EASY/NORMAL/HARD. HARD means that you'll have more targets to shoot in some scenes before advancing to the next scene.

Selecting **DONE** will show you the RIGHT SLOT INFO screen.

Same as LEFT SLOT INFO except the LEVEL of difficulty appears only on the LEFT SLOT INFO screen.

Right & left slot setup can be different if desired.

Selecting **DONE** will show you an OTHER INFO menu.

You may select YES for **DUAL LANGUAGE** if you have a dual language disk in the laser disk player. If YES is selected, then the player will have a choice of languages when the game begins. Select the appropriate language by shooting at a flag which represents the language you wish.

Important Note: If you do NOT have a dual language disk, then selecting YES for DUAL LANGUAGE will cause the screen to go blank when the START switch is pushed to begin a game.

The **ATTRACT AUDIO** selection determines how often the laser disk audio will be heard during the "attract mode". If you select YES, the audio will be heard every time through the attract mode. Selecting 1 means the audio will be silent on alternate times through. Selecting 5 means the audio will be silent 5 out of 6 times through. If dual language is selected, the attract mode will output the Japanese soundtrack.

Selecting **TICKETS** will show a TICKET INFO screen which allows enabling/disabling of the ticket dispenser and adjustment of ticket dispenser operation.

Selecting **DONE** returns to the top-level SERVICE MENU.

TICKET INFO

AVG. TICKETS: 00012
MOST TICKETS: 00025
TOTAL TICKETS: 00327
CLEAR TOTALS
DONE

The **TICKET INFO** screen provides historical information about ticket dispenser operation.

AVG. TICKETS provides the average number of tickets given out per game since **TICKET INFO** was last cleared.

MOST TICKETS and **TOTAL TICKETS** provide the highest number of tickets on any game and the total sum of tickets given out since **TICKET INFO** was last cleared.

Press the **START** button while **CLEAR TOTALS** is flashing to clear this ticket information.

Select **DONE** to move to the **TICKET CONTROL** menu (below).

TICKET CONTROL

TICKETS ACTIVE: YES/NO
ADJUST TICKETS
FEED A TICKET
DONE
PRESS START: CHANGE

The **TICKET CONTROL** screen provides for enabling or disabling ticket dispenser operation, adjusting several parameters which affect ticket payout, and running the ticket dispenser motor to help with loading tickets & testing ticket dispenser operation.

Setting **TICKETS ACTIVE** to **YES** enables ticket dispenser operation. Selecting **NO** disables ticket dispenser operation entirely...other than **FEED A TICKET**.

Selecting **ADJUST TICKETS** shows the **TICKET PAYOUT** menu where details of ticket dispenser payout may be adjusted.

Selecting **FEED A TICKET** causes the ticket dispenser to eject **ONE** ticket...or run until a hole between tickets is detected or approximately 1 second elapses.

Select **DONE** to advance to the **OTHER INFO** screen.

TICKET PAYOUT

FIRST TICKETS: 0...9
SCORE **EVERY**
0250 0250
2000 0500
DONE
PRESS START: CHANGE

Tickets are dispensed as they are earned, not all at once.

The **TICKET PAYOUT** screen has the following features:

FIRST TICKETS determines how many tickets a player gets for each credit used. **FIRST TICKETS** has nothing to do with game scoring...only with credits used.

The **SCORE** and **EVERY** parameters determine when a player earns another ticket. For the example shown, a player will earn one ticket for every 250 points he gets above a score of 250. After the player reaches a score of 2000, it will take 500 points to earn each additional ticket. Both **SCORE** and **EVERY** are adjustable. Set them as you feel is appropriate.

Selecting **DONE** returns to the **OTHER INFO** screen.

This menu provides for **calibrating where the gun shoots**. Aim at the target while holding the trigger in ... then *tap* the START button for a moment.

While the START button is pressed and the gun is triggered, the main computer board defines the spot where the gun is pointing as the center of the screen. When the START button is NOT pressed, you will see a "splotch" for each trigger pull. After calibration, this "splotch" should overlay the calibration target ... within your ability to accurately point the gun at the calibration target.

*Verify gun performance by shooting around the screen borders. **Balance the gun calibration side-to-side & top-to-bottom.*** You should be able to shoot as far left as you can shoot to the right and as far up as down. If not, recalibrate until you can. Calibration should be done at normal playing distance.

Be sure the gun lens is clean, free of smudges or dust, and the lens is not chipped. The screen should be bright, but not washed out, and the game should NOT be located in bright sunlight or direct fluorescent lights.

If you're having trouble shooting at the extreme left edge, try calibrating SLIGHTLY to the right edge of the calibration target. Similarly, to be able to shoot lower on the screen, try calibrating SLIGHTLY above the calibration target.

Press the SERVICE button to exit this calibration screen.

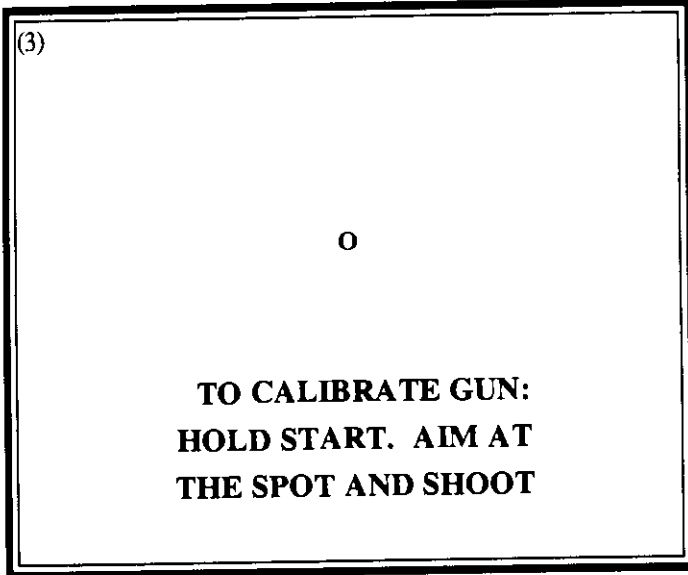

Older guns may need **photodetector realignment** occasionally due to player abuse of the gun. (Newer guns with a plastic tube in the gun barrel do not require realignment.) The photodetector is located on the small PC board inside the gun. Adjust the photodetector position by bending its leads slightly until it appears centered when viewed through the lens of an assembled gun. Also check that **component leads** on the back side of the gun shot board are **not shorting** to the metal gun case. **Check the 4-wire connector** to the gun shot board for good connections also.

The first **HARDWARE TEST** is a **COLOR BAR** screen. This screen is useful for adjusting monitor colors. The color bars are stored on the laser disk and displayed during this test.

The second screen involves a test of the main computer board audio. (To test laser disk audio, connect the laser disk player to to an audio amplifier, or directly to the audio input of the 50" monitor (if applicable), or view the signals on an oscilloscope). The **audio test** shows AUDIO-0/AUDIO-1/AUDIO-2/AUDIO-3 on the screen. Only one audio output from the main computer board is used even though it has two audio outputs. Thus, if the CN4 audio connector on the main computer board is connected to the TAOS (audio amplifier) board, you will hear the test sound **ONLY** when **AUDIO 0** and **AUDIO 3** are displayed. This is normal. If the CN3 audio jack on the main computer board is used, you will hear sounds only for **AUDIO 1** and **AUDIO 2**.

Press SERVICE to exit to a SWITCH TEST screen.

(4)

HARDWARE TESTS

(COLOR BARS)

(AUDIO TEST)

SWITCH TEST

LEFT COIN	OPEN/CLOSED
RIGHT COIN	OPEN/CLOSED
SERVICE	OPEN/CLOSED
START	OPEN/CLOSED
HOLSTER	OPEN/CLOSED
TRIGGER	OPEN/CLOSED

The third screen of the **HARDWARE TESTS** checks the ability of the **main computer board to read various switches**. As you close each switch, you should see the screen message for that switch change from **OPEN** to **CLOSED** when the main computer board recognizes the closure.

Note that **screen update takes about 1 second** so HOLD each switch closed until you see the screen message has changed.

Operate the **SERVICE** button last, because it clears this screen and moves to the next test.

The **START** message tests the front panel **START** switch.

The **LEFT COIN** and **RIGHT COIN** message tests the coin acceptors. If present, a dollar bill acceptor should register on the **RIGHT COIN** input.

The **HOLSTER** message tests the mercury switch for the **RELOAD** function in the Mad Dog McCree game. The screen should show the **HOLSTER** as **CLOSED** when the gun is pointed down and **OPEN** when the gun barrel is horizontal.

The **TRIGGER** message shows that the trigger switch is working and being recognized by the main computer board.

TESTING ROMS

This **ROM TEST** screen appears briefly during the main computer board's verification of the **RAM & EPROMs** on the **RAM/ROM card**. If the contents of the **RAM & EPROMs** are valid, the test program returns to the top-level service menu. If an error is detected, the test program halts at this screen and displays the error message ROM CHECKSUM FAILURE. If you see this message, first check that the **IC chips** on the **RAM/ROM board** are properly seated and that the **RAM/ROM board** itself is properly seated on the main computer board.

If **RAM contents** have unexpectedly changed, the message "**RAM CHECKSUM ERROR ... RESETTING ADJUSTS**" will be displayed. This message means that the main computer has assigned default values for all adjustable parameters and has reset all coin information and game statistics. This may occur due to **RAM battery failure (5-yr RAM)**, as a result of installing updated **EPROMs**, or when a **RAM/ROM card** is installed for the first time.

SPACE PIRATES & WHO SHOT JOHNNY ROCK

SERVICE MENUS

The SERVICE MENUS of these games provide built-in coin accounting, operator adjustment of the cost to play the game, gun calibration, and various hardware tests. Select the SERVICE mode by pushing the SERVICE button located behind the coin acceptor panel. You will then see the screens described below.

SERVICE MENU

- (1) COIN INFO
 - (2) GAME SETTINGS
 - (3) GUN AIMING
 - (4) HARDWARE TESTS
- DONE
PRESS START: SELECT

This is the first screen you'll see after pressing the SERVICE button. The numbers in parentheses are not displayed, but are here to direct you to a selected sub-menu.

COIN INFO provides money receipts information.

GAME SETTINGS allows you to adjust the cost to play the game, the cost to continue the game, and the level of difficulty.

GUN AIMING allows you to calibrate where the gun shots are detected versus where you aim.

HARDWARE TESTS include a color-bar screen, an audio test, switch tests (SERVICE switch, left & right COIN, START, and TRIGGER switches), and a test of the RAM & ROMs on the RAM/ROM card.

Select DONE when finished and ready to return to normal game-playing mode.

(1) LEFT COINS: 00200
RIGHT COINS: 00400
TOTAL GAMES: 00075
AVG. TIME: 02:16
MOST TIME: 09:25
PRESS START: CLEAR

This screen provides information about money taken in by the game. This first screen shows information since you last CLEARed this screen... by pressing the START button. This information can be erased ... see the next screen for permanent coin information.

You MUST press the SERVICE button to exit this screen. You will then see a screen which lists **permanent** TOTALs of coin information.

TOTAL LEFT COINS: 00418
TOTAL RIGHT COINS: 00213
GAMES TO DATE: 00119
CONTINUE GAMES: 00275

This screen gives **permanent** coin information so separate mechanical coin counters are not necessary.

These numbers cannot be reset.

However, if the RAM/ROM card is replaced or update EPROMs are installed, the information stored on the RAM/ROM card will be different. Since these numbers can't be adjusted, you should WRITE DOWN these numbers before replacing or updating a RAM/ROM card.

Press SERVICE to return to the top-level service menu.

(2)

LEFT SLOT INFO

COINS PER TICK: 4
CONTINUE COINS: 2
CREDITS PER TICK: 3
LEVEL: EASY
DONE
PRESS START: CHANGE

RIGHT SLOT INFO

COINS PER TICK: 4
CONTINUE COINS: 2
CREDITS PER TICK: 1
DONE
PRESS START: CHANGE

LANGUAGE INFO

DUAL LANGUAGE YES/NO
ATTRACT AUDIO YES/1...9
PRESS START: CHANGE

COINS PER TICK: 0...8 are valid: 0 = games are FREE

CONTINUE COINS: 0...8 valid: 0=FREE game continuation

CREDITS PER TICK: 1...8 are valid:

With this setup the player gets 3 plays (CREDITS PER TICK) per dollar (COINS PER TICK) but continuing only costs 50 cents. (Assuming 25 cent coins). **It is likely that you'll want to set the CREDITS PER TICK value to 1** so that the player gets 1 game play for 4 coins (in this case) or for whatever number you have set COINS PER TICK to.

Valid settings for LEVEL are EASY/NORMAL/HARD. HARD means that you'll have more targets to shoot in some scenes before advancing to the next scene.

Selecting DONE will show you the RIGHT SLOT INFO screen.

Same as LEFT SLOT INFO except the LEVEL of difficulty appears only on the LEFT SLOT INFO screen.

Right slot setup can be different from Left slot info if desired.

Selecting DONE moves to the LANGUAGE INFO menu.

You may select YES for DUAL LANGUAGE if you have a dual language disk in the laser disk player. If YES is selected, then the player will have a choice of languages when the game begins. Select the appropriate language by shooting at a flag which represents the language you wish.

Important Note: If you do NOT have a dual language disk, then selecting YES for DUAL LANGUAGE will cause the screen to go blank when the START switch is pushed to begin a game.

The ATTRACT AUDIO selection determines how often the laser disk audio will be heard during the "attract mode". If you select YES, the audio will be heard every time through the attract mode. Selecting 1 means the audio will be silent on alternate times through. Selecting 5 means the audio will be silent 5 of 6 times through. If dual language is selected, the attract mode will output the Japanese soundtrack.

Selecting DONE returns to the top-level SERVICE MENU.

(3)



**TO CALIBRATE GUN:
HOLD START. AIM AT
THE SPOT AND SHOOT**

Older guns may need **photodetector realignment** occasionally due to player abuse of the gun. (Newer guns with a plastic tube in the gun barrel do not require realignment.) The photodetector is located on the small PC board inside the gun. Adjust the photodetector position by bending its leads slightly until it appears centered when viewed through the lens of an assembled gun. Also check that **component leads** on the back side of the gun shot board are **not shorting** to the metal gun case. **Check the 4-wire connector** to the gun shot board for good connections also.

(4)

HARDWARE TESTS

(COLOR BARS)

(AUDIO TEST)

This menu provides for **calibrating where the gun shoots**. Aim at the target while holding the trigger in ... then **tap** the START button for a moment to set gun calibration. Gun calibration values are stored in battery-backed RAM when game power is OFF.

While the START button is pressed and the gun is triggered, the main computer board defines the spot where the gun is pointing as the center of the screen. When the START button is NOT pressed, you will see a "shot box" for each trigger pull. After calibration, this "shot box" should overlay the calibration target ... within your ability to accurately point the gun at the target.

*Verify gun performance by shooting around the screen borders. **Balance the gun calibration side-to-side & top-to-bottom.*** You should be able to shoot as far left as you can shoot to the right and as far up as down. If not, recalibrate until you can. Calibration should be done at normal playing distance.

Be sure the gun lens is clean, free of smudges or dust, and the lens is not chipped. The screen should be bright, but not washed out, and the game should not be located in bright sunlight or fluorescent lights.

If you're having trouble shooting at the extreme left edge, try calibrating SLIGHTLY to the right edge of the calibration target. Similarly, to be able to shoot lower on the screen, try calibrating SLIGHTLY above the calibration target.

Press **SERVICE** to return to the top-level **SERVICE MENU**.

The first **HARDWARE TEST** is a **COLOR BAR** screen. This screen is useful for adjusting monitor colors. The color bars are stored on the laser disk and displayed during this test. Screen colors may be affected if the genlock is out of adjustment.

The second screen involves a test of the main computer board **AUDIO**. (To test laser disk audio, connect the laser disk player to an audio amplifier, or directly to the audio input of the 50" monitor (if applicable), or view the signals on an oscilloscope.) The **audio test** shows **AUDIO-0/AUDIO-1/AUDIO-2/AUDIO-3** on the screen. Only one audio output from the main computer board is used even though it has two audio outputs. Thus, if the CN4 audio connector on the main computer board is connected to the TAOS (audio amplifier) board, you will hear the test sound **ONLY** when **AUDIO 0** and **AUDIO 3** are displayed. This is normal. If the CN3 audio jack on the main computer board is used, you will hear sounds only for **AUDIO 1** and **AUDIO 2**.

Press the **SERVICE switch** to exit to a **SWITCH TEST** screen.

SWITCH TEST

LEFT COIN	OPEN/CLOSED
RIGHT COIN	OPEN/CLOSED
SERVICE	OPEN/CLOSED
START	OPEN/CLOSED
HOLSTER 1	CLOSED/OPEN
HOLSTER 2	CLOSED/OPEN
TRIGGER	OPEN/CLOSED

The third screen of the **HARDWARE TESTS** checks the **ability of the main computer board to read various switches**. As you close each switch, you should see the screen message for that switch change from **OPEN** to **CLOSED** when the main computer board recognizes the closure.

Note that **screen update takes about 1 second** so HOLD each switch closed until you see the screen message has changed.

Operate the **SERVICE** button last, because it clears this screen and moves to the next test.

The **START** message tests the front panel **START** switch.

The **LEFT COIN** and **RIGHT COIN** messages test the coin acceptors. If present, a dollar bill acceptor should register on the **RIGHT COIN** input.

The **HOLSTER 1 & 2** messages test the mercury switch for the **RELOAD** function in the **Mad Dog McCree** game. These messages are superfluous with the **Space Pirates** game because **Space Pirates** guns don't have a mercury switch so ignore the displayed messages. If a gun with a mercury switch should somehow get connected to this game, these messages will change together since only one gun is permitted with **SPACE PIRATES**.

The **TRIGGER** message shows that the trigger switch is working and being recognized by the main computer board.

TESTING ROMS

ROM OK

This **ROM TEST** screen appears briefly during the main computer board's verification of the **RAM & EPROMs** on the **RAM/ROM** card. If the contents of the **RAM & EPROMs** are valid, you will see the **ROM OK** message on the screen for about 1 second before returning to the top-level **SERVICE MENU**. If an error is detected, the test program halts at this screen and displays the error message ROM CHECKSUM FAILURE. If you see this message, first **check that the IC chips on the RAM/ROM board are properly seated and that the RAM/ROM board itself is properly seated on the main computer board**.

If **RAM** contents have unexpectedly changed, the message "**RAM CHECKSUM ERROR...RESETTING ADJUSTS**" will be displayed. This message means that the main computer has assigned default values for all adjustable parameters and has reset all coin information and game statistics. This may occur due to **RAM** battery failure (5-yr **RAM**), as a result of installing updated **EPROMs**, or when a **RAM/ROM** card is installed for the first time.

GALLAGHER'S GALLERY SERVICE MENUS

The Gallagher game has a SERVICE MENU which provides built-in coin accounting, operator adjustment of the cost to play the game, gun calibration, and various hardware tests. Select the SERVICE mode by pushing the SERVICE button located behind the coin acceptor panel. You will then see the screens described below.

SERVICE MENU

- (1) COIN INFO
- (2) GAME SETTINGS
- (3) GUN AIMING
- (4) HARDWARE TESTS
- (5) TICKETS

DONE

PRESS START: SELECT

PRESS SERVICE: NEXT

This is the first screen you'll see **after pressing the SERVICE button**. The numbers in parentheses are not displayed, but are here to direct you to a selected sub-menu.

COIN INFO provides money receipts information.

GAME SETTINGS allows you to set up the cost to play the game, the cost to continue the game, and, on later software versions, the level of difficulty.

GUN AIMING allows you to calibrate where the gun shots are detected versus where you aim.

HARDWARE TESTS include a color-bar screen, an audio test, switch tests (SERVICE switch, left & right COIN, START, and TRIGGER switches), and a test of the ROMs on the RAM/ROM card.

TICKETS allows adjustment of ticket dispenser settings.

Select **DONE** when finished and ready to return to normal game-playing mode.

This screen provides information about money taken in by the game. This first screen shows information since you last **CLEARed** this screen...by pressing the START button.

CLEARing this screen also **resets the top-scorers** screen (GALLAGHER'S GREAT GUNS) to a default pattern.

You **MUST** press the SERVICE button to exit this screen. You will then see a screen which lists permanent **TOTALs** information.

(1) LEFT COINS: 0200
RIGHT COINS: 0400
TOTAL GAMES: 0075
CONTINUE GAMES: 0055
2 PLAYER GAMES: 0045
2 PLAYER CONT: 0040
AVG. TIME: 02:16
MOST TIME: 09:25
PRESS START: CLEAR
PRESS SERVICE: NEXT

MACHINE TOTALS

TOTAL LEFT COINS: 00418
TOTAL RIGHT COINS: 00213
GAMES TO DATE: 00119
CONTINUE GAMES: 00275
TWO PLAYER: 00055
TWO PLAYER CNT: 00043
PRESS SERVICE: NEXT

This screen gives **permanent** coin information. This screen cannot be reset. However, if the RAM/ROM card is replaced, this will be affected. Since these numbers can't be reset to zero, you should **write down** these numbers from your game machine for your own records.

(2)

LEFT SLOT INFO

COINS PER TICK: 4
CONTINUE COINS: 2
CREDITS PER TICK: 3
LEVEL: EASY
DONE
PRESS START: CHANGE
PRESS SERVICE: NEXT

RIGHT SLOT INFO

COINS PER TICK: 4
CONTINUE COINS: 2
CREDITS PER TICK: 1
DONE
PRESS START: CHANGE
PRESS SERVICE: NEXT

BULLET SETTINGS

START BULLETS: 0075
CONTINUE BULLETS: 0050
MISS BULLETS: 3
BONUS BULLETS: 25
DONE
PRESS START: CHANGE
PRESS SERVICE: NEXT

COINS PER TICK: 0...8 are valid: 0 = games are FREE

CONTINUE COINS: 0...8 valid: 0=FREE game continuation

CREDITS PER TICK: 1...8 are valid:

With this setup the player gets 3 plays (CREDITS PER TICK) per dollar (COINS PER TICK) but continuing only costs 50 cents. (Assuming 25 cent coins). It is likely that you'll want to set the CREDITS PER TICK value to 1 so that you get 1 game play for 4 coins (in this case) or for whatever number you have set COINS PER TICK to.

Valid settings for **LEVEL** are EASY/NORMAL/HARD. HARD means that you'll have more targets to shoot in some scenes before advancing to the next scene.

Select **DONE** to advance to the RIGHT SLOT INFO screen.

Same as LEFT SLOT INFO except the LEVEL of difficulty appears only on the LEFT SLOT INFO screen.

Right slot setup can be different from Left slot info if desired.

Selecting **DONE** moves to the BULLET SETTINGS menu.

START BULLETS defines the initial number of bullets at the start of a game. **CONTINUE BULLETS** defines the number of bullets received when the player continues a game. **MISS BULLETS** defines how many bullets are SUBTRACTED for not completing a scene. **BONUS BULLETS** are bullets ADDED for good BONUS ROUND performance. Selecting **DONE** moves to the ATTRACT MODE menu.

START BULLETS: Options are: 025/050/...300 by 25's.

CONTINUE BULLETS: Opts are: 025/050/...300 by 25's

MISS BULLETS: Options are: 0...10 by 1's

BONUS BULLETS: Options are: 5...50 by 5's

MISS BULLETS refers to bullets taken away when a player fails to shoot targets before the scene fades. However, there are some exceptions...scenes where it's inappropriate to subtract MISS BULLETS. These include scenes such as the "bottle toss", "medicine bottles", "clothesline", and targets that fly back and forth.

BONUS BULLETS are given during BONUS ROUNDS which occur after finishing "worlds." For the bonus rounds where the lovely lady shows a tin can or a hairspray can, 1/4th of the BONUS BULLETS number are given for each of the 4 targets ... given to whichever player shoots each bonus round target. For the bonus round with the "whiskey jug", the entire BONUS BULLETS amount is given to the player who shoots the swinging whiskey jug.

ATTRACT MODE
ATTRACT AUDIO: YES/1..9

DONE

PRESS START: CHANGE
PRESS SERVICE: NEXT

The **ATTRACT AUDIO** selection determines how often the laser disk audio will be heard during the "attract mode"...the time prior to a player beginning a game. If you select YES, the audio will be heard every time through the attract mode. Selecting 1 means the audio will be silent on alternate times through. Selecting 5 means the audio will be silent 5 out of 6 times through.

Selecting **DONE** returns to the SERVICE MENU.

This menu provides for **calibrating where the gun shoots**. You will see a **target** similar to this in the center of the screen. Press and hold the START button and then fire the gun while accurately pointing at the target. When this is done, the main computer board defines the spot where the gun is pointing as the center of the screen. Calibration occurs only when the START button is pressed. When the START button is NOT pressed, you will see a "shot box" for each trigger pull. After calibration, this "shot box" should overlay the calibration **target** ... within your ability to accurately point the gun at the calibration target. Calibration should be done with the end of the gun barrel about 6 inches from the front glass. Be sure the lens is clean, free of smudges or dust, & is not chipped.

If you have trouble shooting at the extreme left screen edge, try calibrating SLIGHTLY to the right edge of the calibration target. Similarly, to be able to shoot lower on the screen, try calibrating SLIGHTLY above the calibration target.

Press the SERVICE button to exit calibration screen and return to the top SERVICE MENU.

NOTE: In a few early production games, ONLY the LEFT-hand START button performs calibration. If holding in a START button causes the gunshot "splotch" to disappear when a trigger is pulled, then that START button performs the gun calibration function.

The first **HARDWARE TEST** is a **COLOR BAR** screen. The second screen involves a **test of the main computer board audio**. The audio test shows AUDIO-0/AUDIO-1/AUDIO-2/AUDIO-3 on the screen. Only one audio output from the main computer board is used even though it has two audio outputs. Thus, if the CN4 audio connector on the main computer board is connected to the TAOS (audio amplifier) board, you will hear the test sound ONLY when AUDIO 0 and AUDIO 3 are displayed. This is normal. If the CN3 audio jack on the main computer board is used, you will hear sounds only for AUDIO 1 and AUDIO 2.

Press **SERVICE** to exit the color bar and audio test screens.

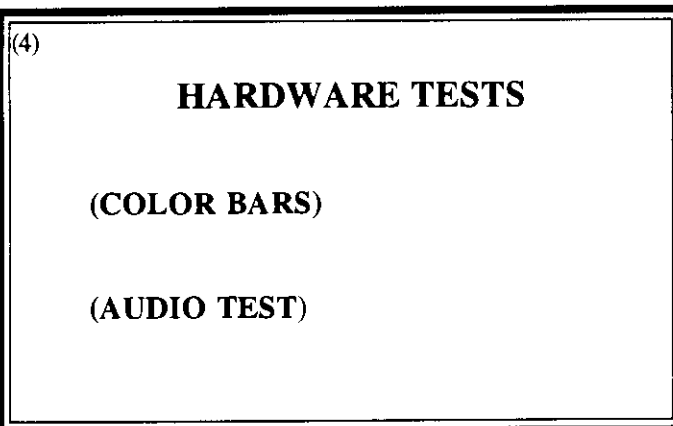
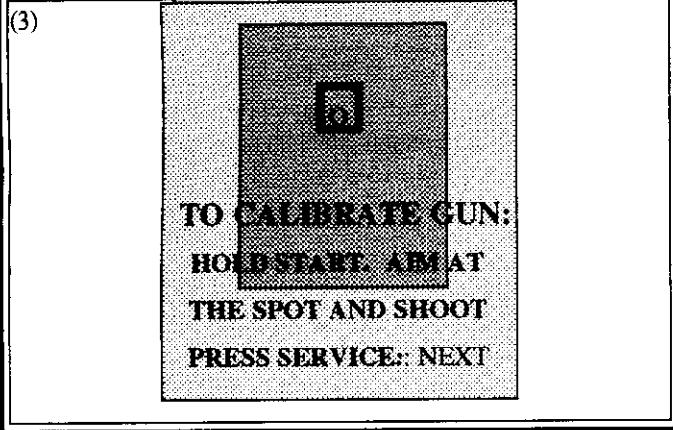

SWITCH TEST

LEFT COIN	OPEN/CLOSED
RIGHT COIN	OPEN/CLOSED
SERVICE	OPEN/CLOSED
LEFT START	OPEN/CLOSED
RIGHT START	OPEN/CLOSED
LEFT TRIGGER	OPEN/CLOSED
RIGHT TRIGGER	OPEN/CLOSED

The third screen of the **HARDWARE TESTS** check the ability of the main computer board to read various switches. As you close each switch, you should see the screen message for that switch change from **OPEN** to **CLOSED** when the main computer board recognizes the closure.

Note that screen update takes about 1 second so pull AND HOLD the trigger at least 1 second.

Operate the SERVICE button last, because it clears this screen and moves to the next test. Hold for about 2 seconds or push twice to exit the **switch test** screen.

The **LEFT START** and **RIGHT START** messages test the front panel **START** buttons.

The **LEFT TRIGGER** and **RIGHT TRIGGER** messages show that the associated trigger switch is working.

TESTING ROMS

ROM OK

This screen shows the results of the main computer board's verification of the EPROMs on the RAM/ROM card. If the contents of the EPROMs are valid, you will see the **ROM OK** message on the screen for about 1 second before returning to the **SERVICE MENU...** unless a ROM error (CRC mismatch) is detected in which case the test program halts at this screen.

TICKET INFO

AVG. TICKETS	00003
MOST TICKETS:	00032
TOTAL TICKETS:	00089

CLEAR TOTALS

ADJUST TICKETS

FEED A TICKET

DONE

PRESS START: CHANGE

PRESS SERVICE: NEXT

This screen provides information about tickets dispensed. You may clear the ticket statistics by pressing the **START** button when **CLEAR TOTALS** is flashing.

Another screen, the **TICKET CONTROL** screen, is shown after you select **ADJUST TICKETS** when it is flashing (see below).

FEED A TICKET is useful to advance the ticket dispenser mechanism ... for example if the chain of tickets breaks, etc. You may use this function any time, but there is another **FEED A TICKET** message which conveniently appears when the game has run out of tickets.

When the game runs out of tickets, an alarm will sound and the screen will display a message telling the player to get the manager. The screen will then display a message telling the manager how many tickets the player is owed. The manager should hand those tickets to the player and then reload the game with tickets. The game will **NOT** dispense the tickets owed to the player immediately after reloading tickets.

Select **DONE** to return to the main **SERVICE** menu.

TICKET CONTROL

TICKETS ACTIVE: YES/NO

FIRST TICKETS: 1...9

SCORE	EVERY
-------	-------

00000	00500
-------	-------

00250	02500
-------	-------

03000	05000
-------	-------

10000	10000
-------	-------

30000	20000
-------	-------

WINNER TAKE ALL

-or-

EACH GETS TICKETS

DONE

PRESS START: CHANGE

PRESS SERVICE: NEXT

This screen gives the operator complete control over ticket dispenser operation. The screen at left shows the **DEFAULT values** ... adjust these items to your own preferences.

TICKETS ACTIVE determines if tickets will be dispensed at all. Set to YES for normal ticket dispenser operation or set to NO to disable the ticket dispenser.

FIRST TICKETS specifies how many tickets will be awarded for each coin a player deposits. Tickets are dispensed at the end of the game. First tickets are initially awarded to the player who deposits each coin (see WINNER TAKES ALL).

Five score "threshold" levels are available to define the awarding of tickets. The "**SCORE**" value sets the threshold and the "**EVERY**" value sets the increment of points for which another ticket will be awarded. You may set these values as you wish. Default values are shown here. Both SCORE and EVERY are adjustable. When adjusting SCORE, the number changes slowly for small SCORE values and in larger steps as it gets larger. The same is true for the EVERY adjustments.

WINNER TAKES ALL or **EACH GETS TICKETS** allow you to define who is awarded the tickets that are earned during the game. If **EACH GETS TICKETS** is selected, then the tickets earned by each player are awarded separately to each player.

If **WINNER TAKES ALL** is selected, then the last player in the game is awarded ALL the tickets earned during the game by either player. Of course, a player who has run out of bullets and is thinking about quitting the game my "coin-up" again (within 12 seconds) to try to get all the tickets. If he doesn't coin-up in the 12 seconds, his tickets are awarded to the remaining player. The player who quit (or a new player) can coin-up later (before the other player finishes his game) to try to take back ALL the tickets. If both players happen to run out of bullets on the same screen of the game, then the tickets are awarded to the player who has the highest score.