

SEGA

GP RIDER



GP RIDER UPRIGHT TYPE

OWNER'S MANUAL

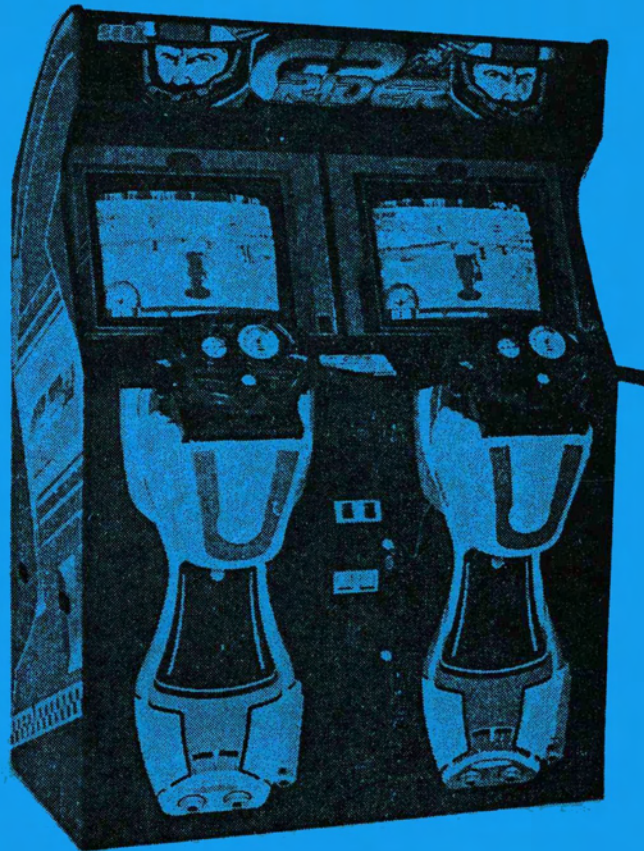

SEGA ENTERPRISES, LTD.

GP RIDER

BY:

SEGA Enterprises, Inc. (U.S.A.)
2149 Paragon Drive
San Jose, California 95131
Phone Number (408) 435-0201
FAX Number (408) 435-0294

SPECIFICATIONS

HEIGHT:..... 71 in.
WIDTH:..... 49 in.
DEPTH:..... 36 in.
NET WEIGHT:..... 463 lb.

Note: This equipment has been tested and found to comply with the limits for a Class A digital device, pursuant to Part 15 of the FCC Rules. These limits are designed to provide reasonable protection against harmful interference when the equipment is operated in a commercial environment. This equipment generates, uses, and can radiate radio frequency energy and, if not installed and used in accordance with the instruction manual, may cause harmful interference to radio communications. Operation of this equipment in a residential area is likely to cause harmful interference in which case the user will be required to correct the interference at his/her own expense.

Table of Contents

Introduction	1
Handling and Installation Precautions	1
Prevention of Counterfeiting and Conversion Labelling	2
Precautions Concerning the Place of Installation	3
F.C.C. Requirements	3
Name of Parts	4
Parts for Design	6
Service Switches	8
Removing the Handle Unit	9
Adjusting the Accelerator/Brake	12
Shift Switches	14
Assembly, Handle Unit	15
Monitor Adjustments	23
Test Mode	24
Bookkeeping	29
Dip Switch Setting Options	32
Eprom Locations	33
Wiring Diagrams	34

NOTE: DESCRIPTIONS HEREIN CONTAINED MAY BE SUBJECT TO IMPROVEMENT OR CHANGES WITHOUT NOTICE.

INTRODUCTION OF THE OWNER'S MANUAL

SEGA ENTERPRISES, LTD., supported by its high electronic technology of LSIs, microprocessors, etc. and a wealth of experience, has for more than 30 years been supplying various innovative and popular game machines to the world market. This OWNER'S manual is intended to provide detailed comments together with all the necessary information covering the operation in general of electronic assemblies, electromechanical servicing control, spare parts, etc. The manual is intended for those who have knowledge of electricity and technical expertise especially in ICs, CRTs, microprocessors, etc. Carefully read so as to acquire sufficient knowledge before working on the machine. Should there be a malfunction, non-technical personnel should under no circumstances touch the interior system.

HANDLING PRECAUTIONS

When installing or inspecting, be very careful of the following points and pay attention to ensure that the player can enjoy the game safely.

- o Be sure to turn the power off before working on the machine.
- o To insert or pull out the plug quickly is dangerous.
- o It is necessary to make sure that the power cord or the grounding wire is not exposed on the road, etc. in a manner so as to be dangerous. Make sure that grounding connections are made safely at the position where specified.
- o Do not use any fuse that does not meet the specified rating.
- o Make complete connections for the IC board and other connectors. Insufficient insertion is very dangerous.

Also, for the IC board circuit inspections, only the logic probe is allowed. The use of a tester is not permitted, so be careful in this regard. After confirming that there are no irregularities, turn the power ON.

PREVENTION OF COUNTERFEITING AND CONVERSION

LABELLING

To prevent counterfeits and conversions, the following labels are put on all the SEGA products. When handling such goods, be sure to confirm the labels. They are used to prevent illegal acts such as the unauthorized copying of the products and the printed circuit boards thereof or carrying on business by manufacturing similar merchandise or by converting, selling or using such products or printed circuit boards.

The following seal is put on the machines manufactured by SEGA

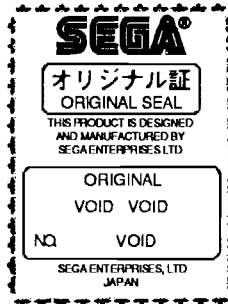

ORIGINAL SEAL

COPYRIGHT NOTICE

This SEGA product has the copyright notice as follows:

© SEGA 1990

This signifies that this work was disclosed in 1990 and is the property of SEGA ENTERPRISES, LTD.

PRECAUTIONS CONCERNING THE PLACE OF INSTALLATION

This is an indoor game machine. Absolutely do not install it outside. Even indoors, avoid installing in places mentioned below so as to ensure proper usage:

- o Places subject to rain or water leakage, or condensation due to humidity.
- o In the proximity of an indoor swimming pool and/or shower.
- o Places subject to direct sunlight.
- o Places subject to heat sources from heating units, etc., or hot air.
- o Vicinity of highly flammable/volatile chemicals or hazardous matter.
- o Sloped surfaces.
- o Vicinity of anti-disaster facilities such as fire exits and fire extinguishers.
- o Places subject to any type of violent impact.
- o Dusty places.
- o Residential Environment - (See F.C.C. statement below)

F.C.C. REQUIREMENTS

The Federal Communications Commission requires that all Class A equipment be verified and labeled as follows:

This equipment complies with the requirements in part 15 of FCC Rules for a Class A computing device. Operation of this equipment in a residential area may cause unacceptable interference to radio and TV reception requiring the operator to take what ever steps are necessary to correct the interference.

This label must be permanently attached in a conspicuous location and the text must be legible. If this label is removed or tampered with, such action is punishable under Section 503 of the Communications Act of 1934 (ACT), as amended.

NAME OF PARTS

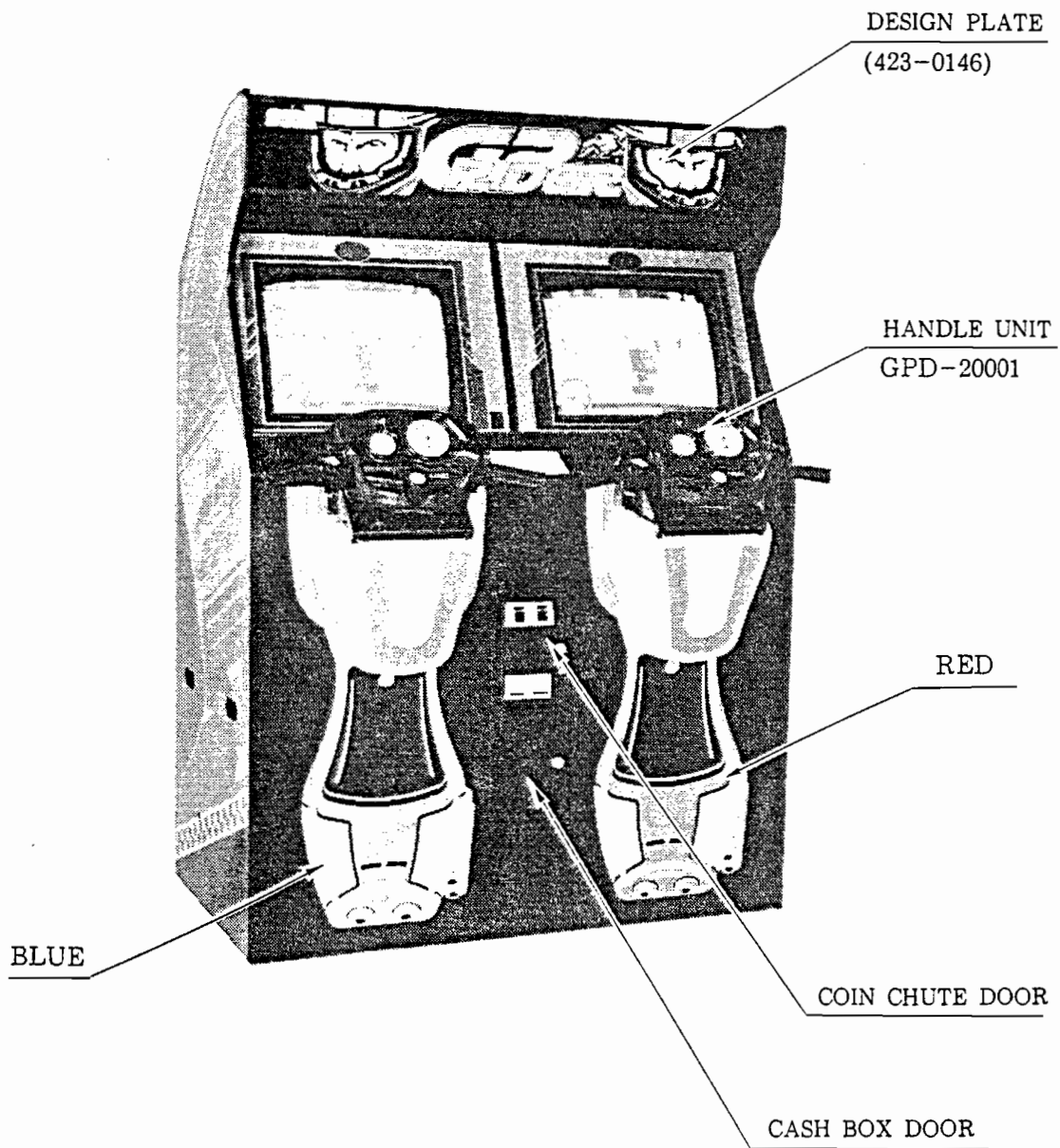

TOOL

(TAMPERPROOF WRENCH)

M4 540-0006-01

M5 540-0007-01

M8 540-0009-01

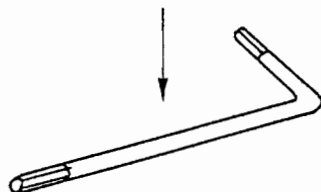

NAME OF PARTS

ASSY SHIELD CASE
GPD-1058

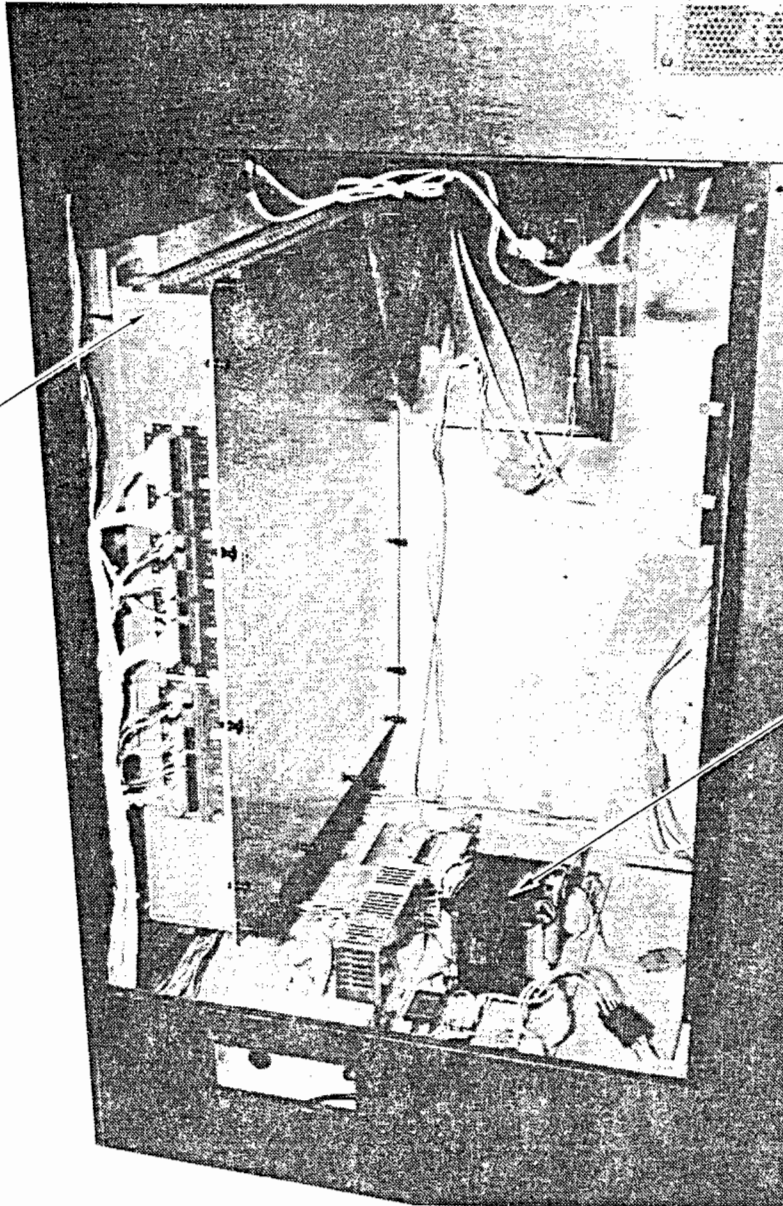

ASSY PWR SPLY
GPD-40001

PARTS FOR DESIGN

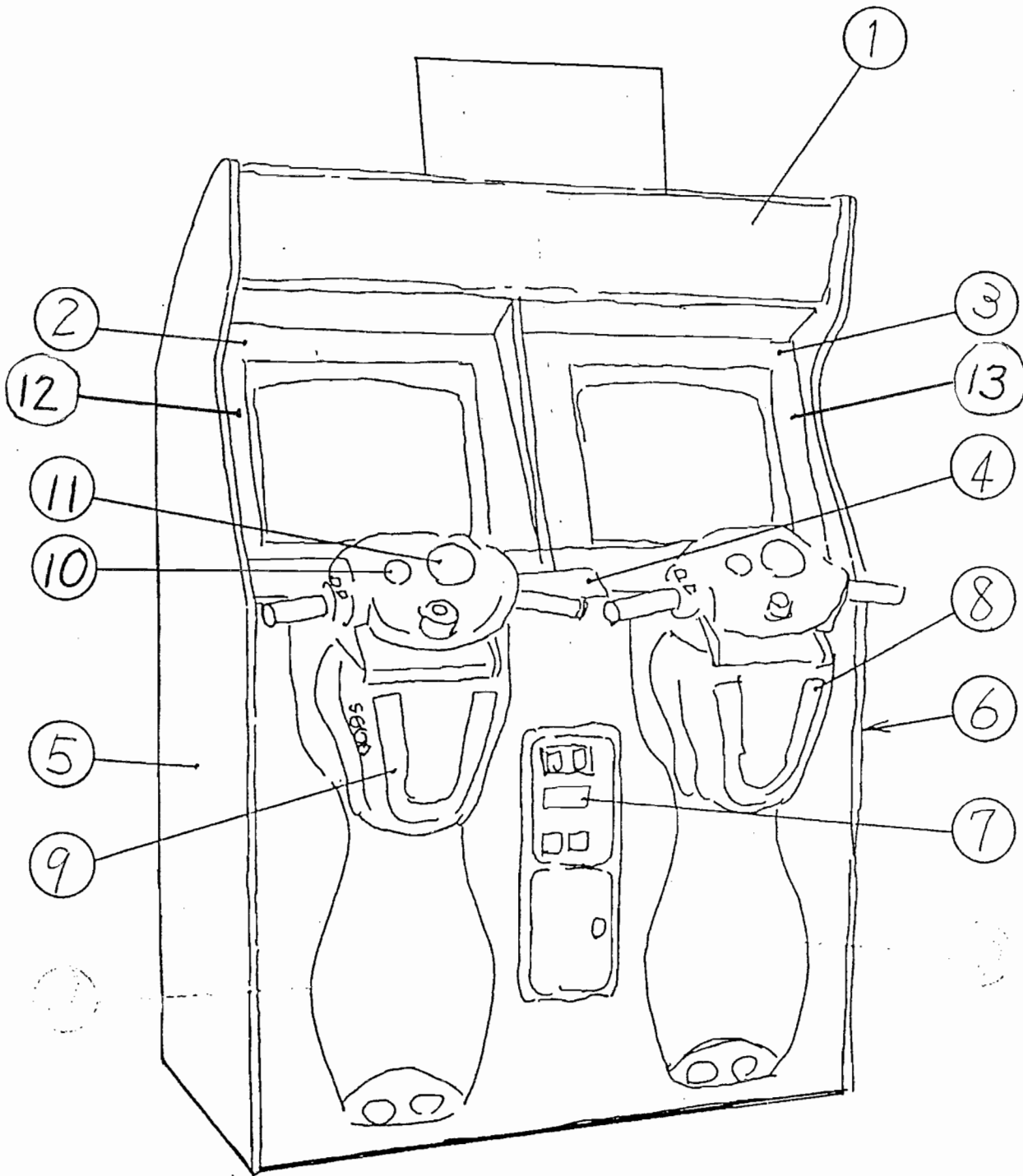

ITEM NO.	PART NO.	DESCRIPTION	NOTE
1	423-0146	Design Plate GP Rider U/R	
2	GPD-1022-A	Front Glass - Left, Clear	
3	GPD-1022-B	Front Glass - Right, Clear	
4	422-0349	Play Instruction Plate, GP Rider U/R	
5	421-7745	Side Decal, GP Rider - Right	
6	421-7744	Side Decal, GP Rider - Left	
7	421-7760	Sticker, Direction (Arrow Red - Blue)	
8	421-7746	Decal, Front Red - Right	
9	421-7747	Decal, Front Blue - Left	
10	HSD-2040-B	Sticker Meter A (Handle Assy)	
11	HSD-2040-C	Sticker Meter B (Handle Assy)	
12	GPD-1023-A	Monitor Card, Blue - Left	
13	GPD-1023-B	Monitor Card, Red - Right	
	560-5164	Xformer, 120 Primary - 18.5 5A, 100 3A Sec.	
	200-5090	Monitor, 19" Standard Resolution	
	837-7273	Communication Board, GP Rider	
	834-7626-01	IC Board, GP Rider	
	839-0329	Filter Board GP Rider A	
	839-0330	Filter Board GP Rider B	
	601-6227-01	Power Amp W/Switching Regulator 12V 5A	

SERVICE SWITCHES

Open the COIN CHUTE DOOR, and the following SERVICE SWITCHES layout will appear :

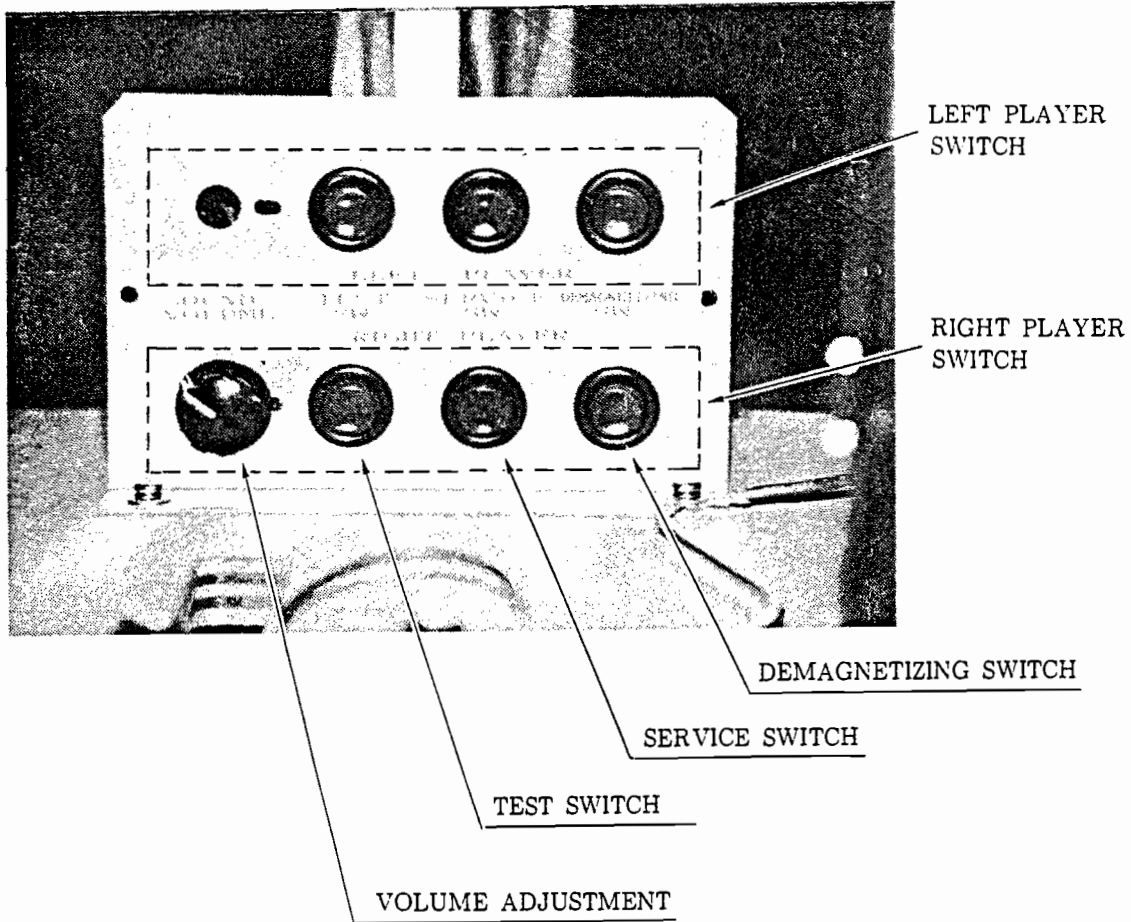

OPERATING INSTRUCTIONS:

- TEST SWITCH.....For operating this switch, see TEST MODE.
- SERVICE SWITCH..... Used for the purpose of servicing and increasing the credits without registering on the meter.
- DEMAGNETIZING SWITCH..... Not Used
- VOLUME ADJUSTMENT.....Used for adjusting the SPEAKER volume.

REMOVING THE HANDLE UNIT

- When adjusting the centering V.R., remove the HANDLE UNIT by using the following procedure:

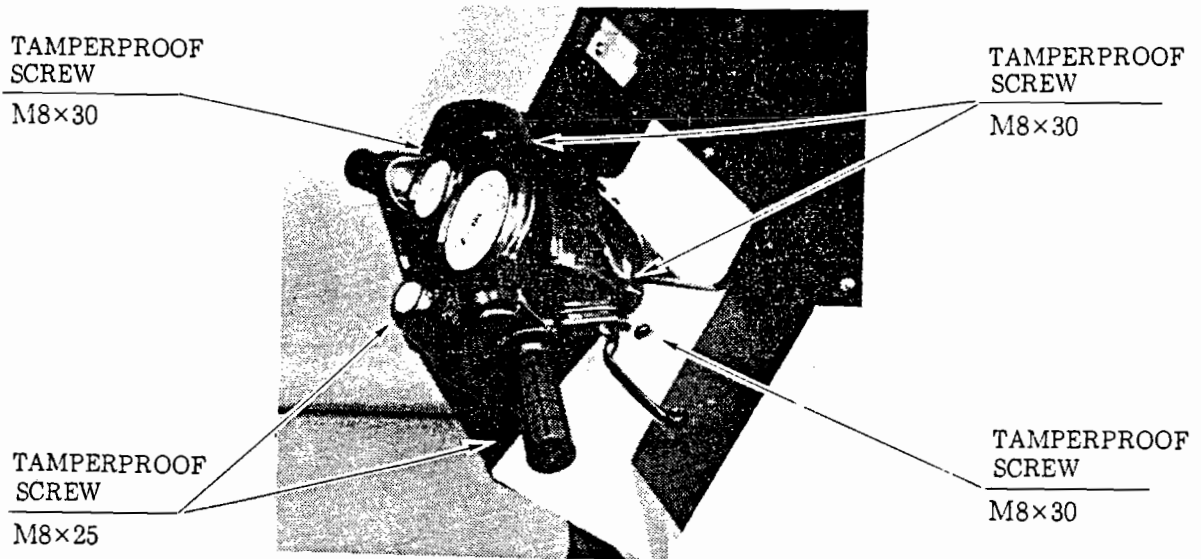

DISASSEMBLING PROCEDURE

For the adjustment of the centering V.R., take off the six TAMPERPROOF SCREWS by using the TAMPERPROOF WRENCH (M8), and the illustrated layout will appear.

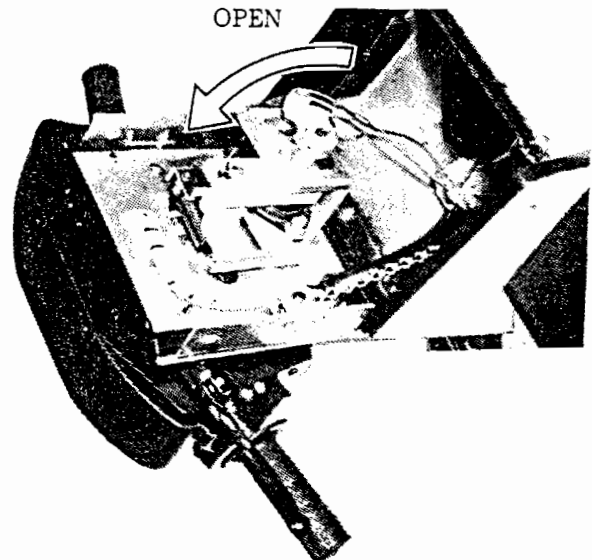

HANDLE'S CENTERING ADJUSTMENT

- o When the HANDLE is in a stationary position, display the following on the screen in the SELF-TEST mode.
- o At this time, if the variable value becomes 80H, it is considered normal.

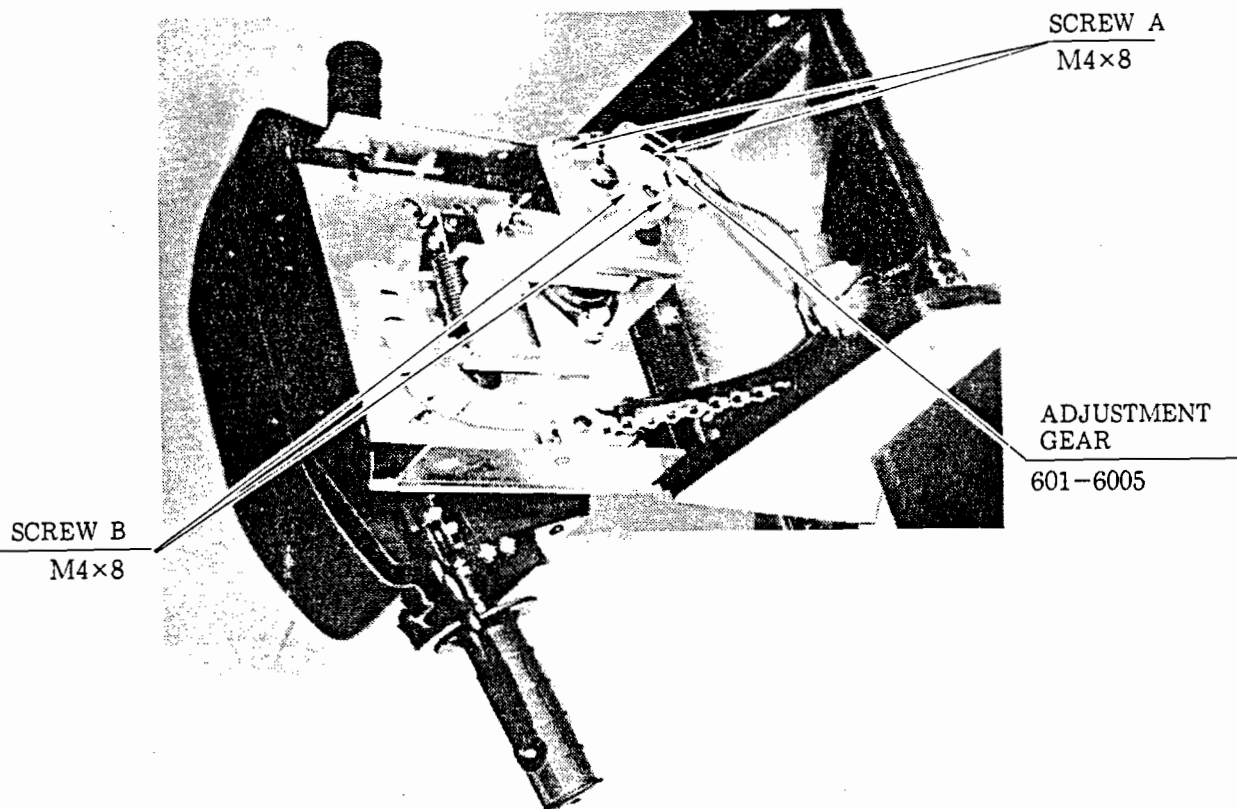

ADJUSTING PROCEDURE

INPUT TEST	
COIN #1 OFF	START OFF
COIN #2 OFF	SERVICE OFF
SHIFT A OFF	
SHIFT B OFF	
BANK	80H
ACCEL	CCH
BRAKE	ECH

- ① The V.R. BRACKET can be moved in the right and the left directions by releasing 2 SCREWS A which fasten it.
- ② Move the V.R. BRACKET to the right to disengage the PINION GEAR and the ADJUSTMENT GEAR. At this time, make adjustments by turning the V.R. SHAFT in a manner so that the variable value falls within the allowable range.
- ③ In the case where fine adjustments are necessary, loosen the ADJUSTMENT GEAR'S SCREWS B and make adjustments as required.

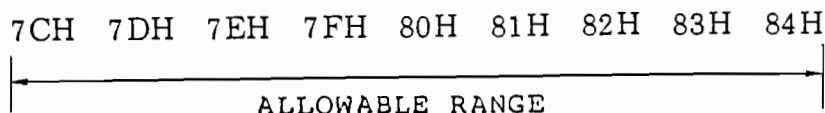

REMOVING THE HANDLE COVER

- o When adjusting the V.R. for the ACCELERATOR/BRAKE, remove the HANDLE COVER by using the following procedure.

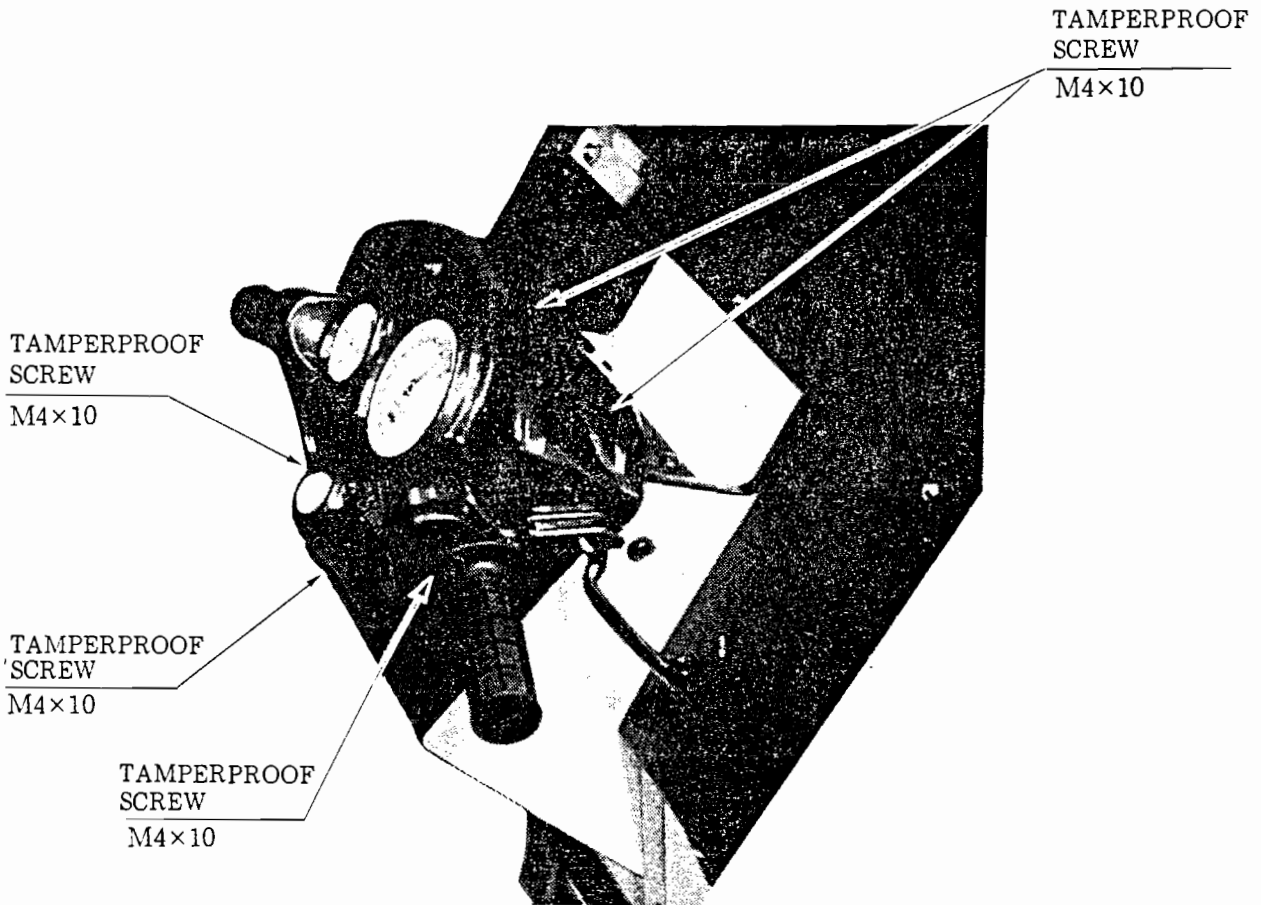

DISASSEMBLING PROCEDURE

- ① Remove 5 SCREWS which fasten the HANDLE COVER by using the TAMPERPROOF WRENCH (M4).
- ② The HANDLE COVER can be detached from the HANDLE UNIT in accordance with ① above. It is removable from the HANDLE UNIT by disconnecting the CONNECTOR (WHITE 4P MINI)

ADJUSTING THE ACCELERATOR/BRAKE

BRAKE SIDE PINION GEAR
601-5252

BRAKE GEAR
601-6005

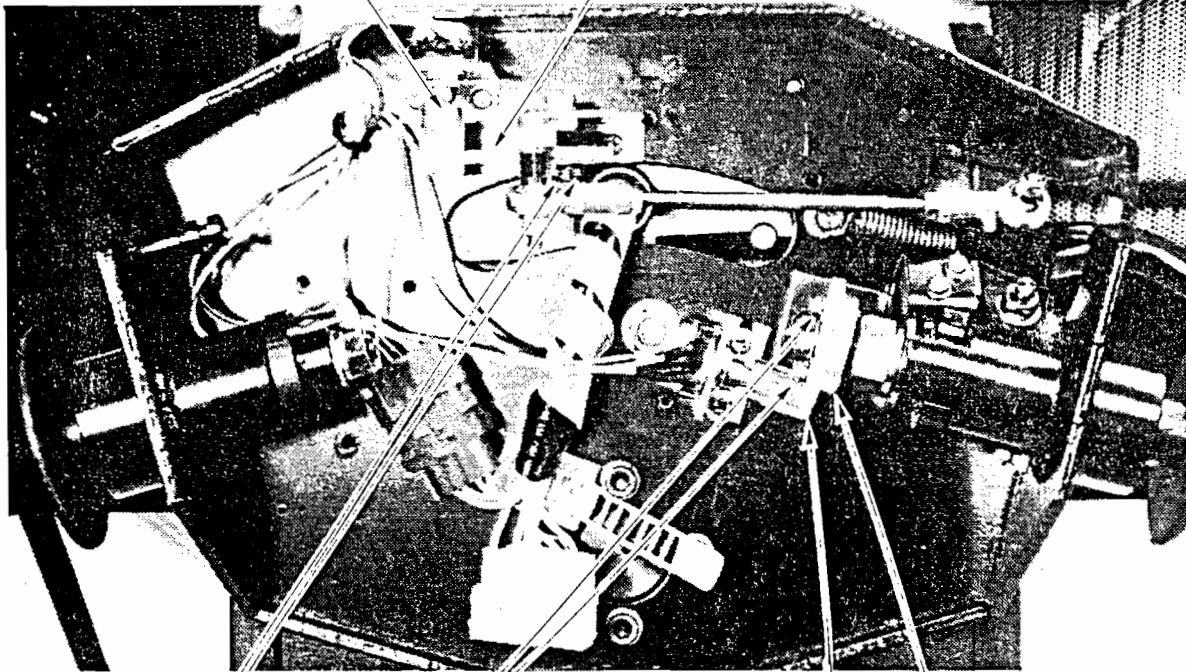

SCREW B
M4×10

SCREW A
M4×10

ACCELERATOR
GEAR
601-6172

ACCELERATOR SIDE
PINION GEAR
601-5252

ADJUSTING THE ACCELERATOR V.R.

- ① Remove the HANDLE COVER (see Page 13).
- ② Loosen SCREWS A and move the GEAR in a manner so that the variable value as specified in P 19 is obtained.
- ③ When the specified variable is obtained, retighten SCREWS A.

ADJUSTING THE BRAKE V.R.

- ① Remove the HANDLE COVER (see P 13).
- ② Loosen SCREWS B and move the GEAR in a manner so that the variable value as specified in P 19 is obtained.
- ③ When the specified variable is obtained, retighten SCREWS B.

REPLACING THE V.R. THE ACCELERATOR/BRAKE

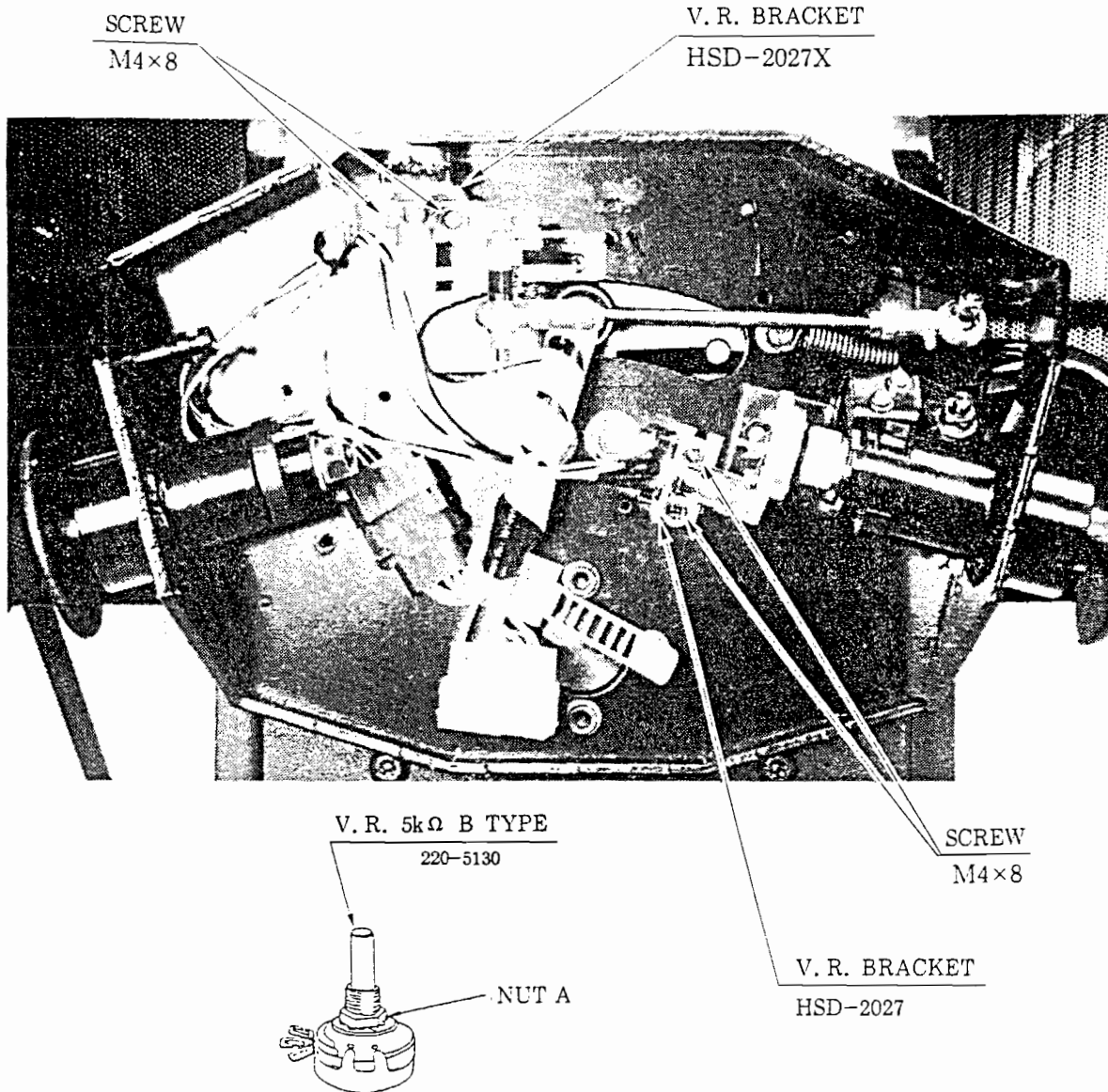

DISASSEMBLING PROCEDURE

1. To remove the BRACKET from the HANDLE UNIT, take off the 2 screws which fasten the V.R. BRACKET.
2. To remove the PINION GEAR attached to the V.R. SHAFT to be replaced, release the 2 SET SCREWS that fasten the PINION GEAR.
3. The V.R. can be removed from the BRACKET by taking off the V.R. SHAFT'S NUT A.
4. After the replacement has been made, reassemble them in sequential order opposite from the above procedure.

REPLACING THE SHIFT SWITCHES

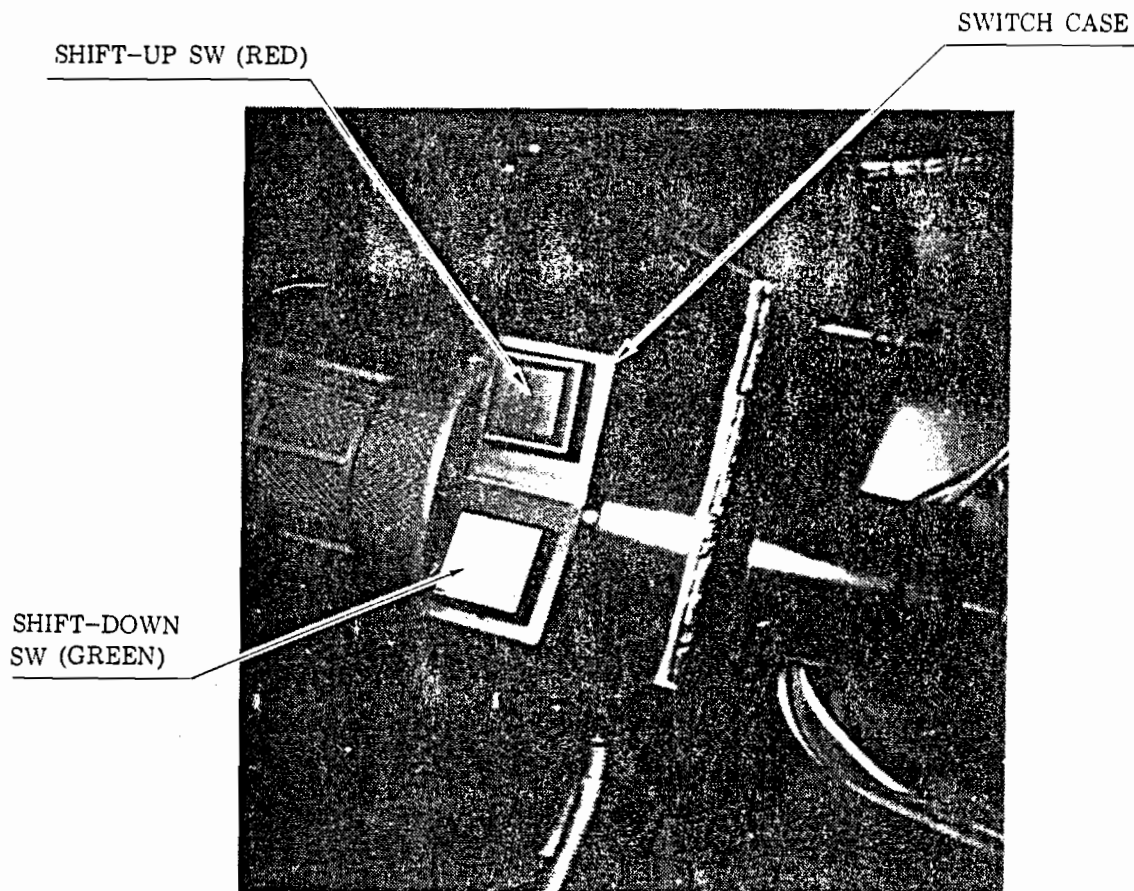

When replacing the SHIFT SWITCH(ES), apply a plier, etc., to the edges of the switch(es), and while slightly moving it up/down and or left/right, take it out. Insert wires to the new switch in the same manner as for the old one, and push it in by matching the switch convex portion and the case concave portion.

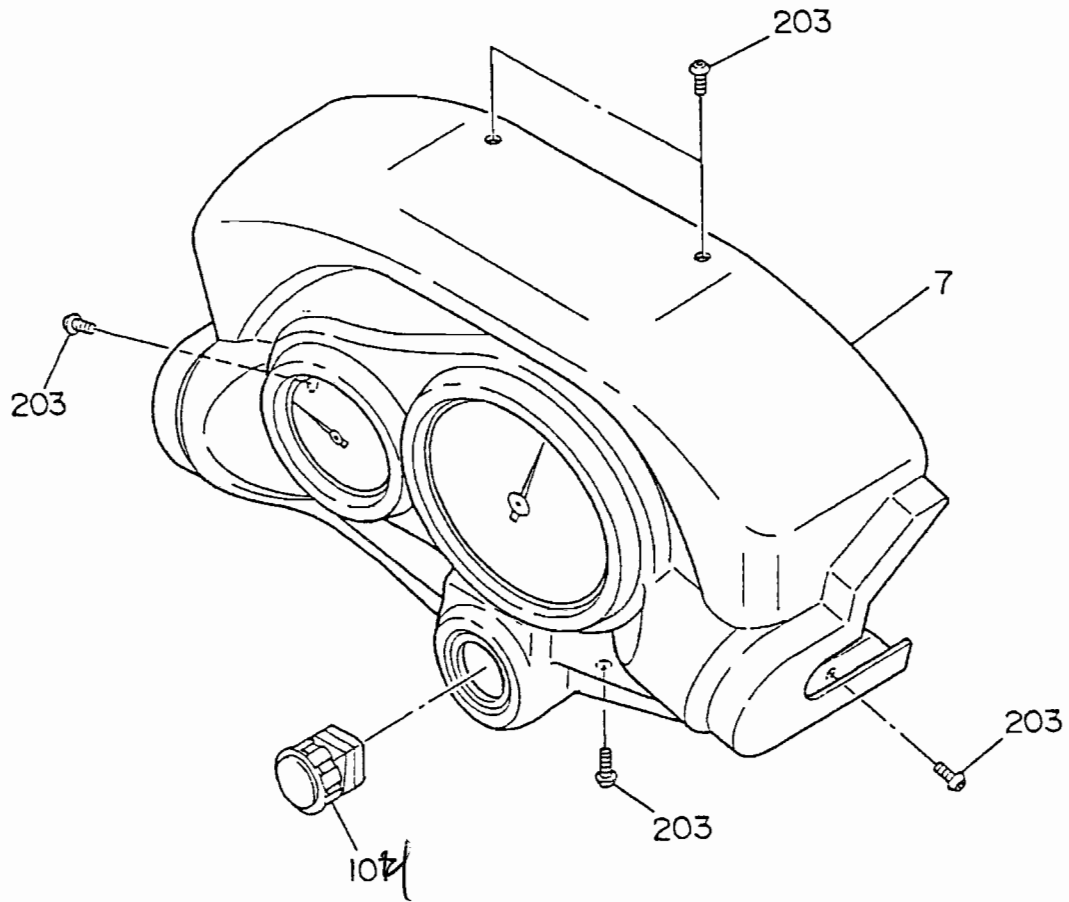

ASSY HANDLE U/R (GPD-20001)

(D-3/8)

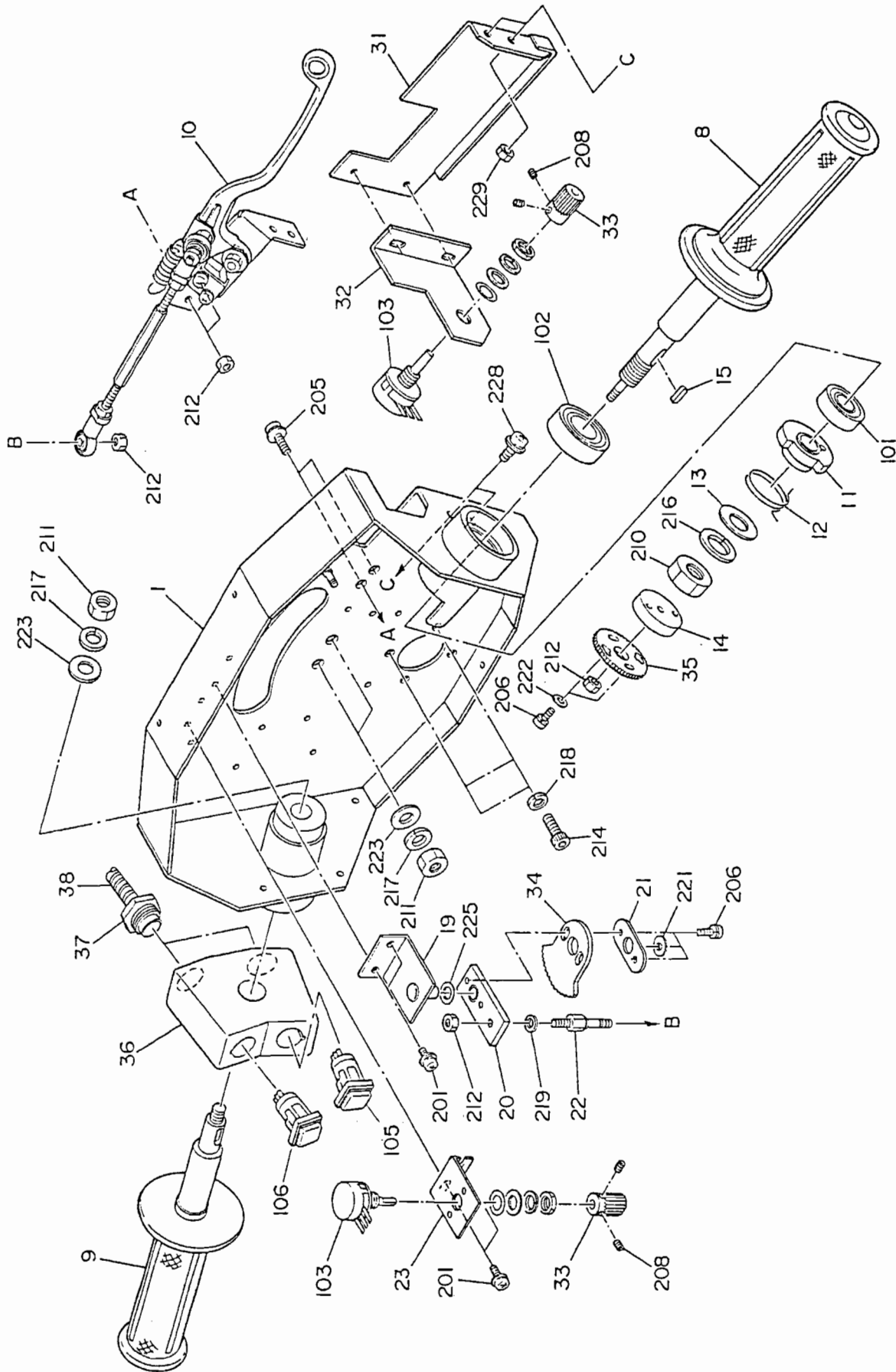

ASSY HANDLE U/R (GPD-20001)

(D-4/8)

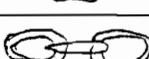
ITEM NO.	PART NO.	DESCRIPTION	NOTE
1	GPD-2010	HANDLE BASE	
2	HSD-2100	ASSY CENTERING	
3	HSD-2030	PANEL HOLDER	
4	HSD-2031	FRONT PANEL	
5	HSD-2032	WOODEN BASE UPPER	
6	HSD-2033	WOODEN BASE LOWER	
7	GPD-2012	HANDLE COVER	
8	HSD-2002	ACCEL GRIP	
9	GPD-2011	SHIFT GRIP	
10	HSD-2004	ASSY BRAKE	
11	HSD-2015	STOPPER DISK	
12	HSD-2016	TORSION SPRING	
13	HSD-2017	SPRING HOLDER	
14	HSD-2018	GEAR HOLDER	
15	HSD-2019	KEY 4x4x12	
16	HSD-2020	SLIDE SPACER	
17	HSD-2042	SLIDE PLATE INNER	
18	HSD-2022	SLIDE HOLDER	
19	HSD-2023	SWING ARM HOLDER	
20	HSD-2024	SWING ARM	
21	HSD-2025	HOLD PLATE	
22	HSD-2026	SWING ARM SHAFT	
23	HSD-2027X	VR BRKT	
24	HSD-2037	CHAIN HOLDER B	
25	HN-5046	SPACER TUBE	
26	HSD-2038	CHAIN	

ASSY HANDLE U/R (GPD-20001)

(D-5/8)

ITEM NO.	PART NO.	DESCRIPTION	NOTE
27	HSD-2034	BUMPER HOLDER R	
28	HSD-2035	BUMPER HOLDER L	
29	HN-5024X	BUMPER	
30	HSD-2036	SLIDE PLATE OUTER	
31	HSD-2043	HOLDER VR BRKT	
32	HSD-2044X	VR BRACKET	
33	601-5410	GEAR 15 ϕ 6	
34	601-6005	ADJUST GEAR	
35	601-6172	GEAR 48	
36	GPD-2007	SWITCH CASE	
37	MX-2020	TUBE HOLDER	
38	MX-2021	PROTECTOR W/S TUBE	
39	421-7752	STICKER UP DOWN	
101	100-5111	BEARING ϕ 12	
102	100-5112	BEARING ϕ 17	
103	220-5130	VOL CONT B-5K OHM	
104	509-5218	PUSH BTN SWITCH 1T YELLOW W/LAMP	
105	509-5003	PUSH BUTTON SW 1T \square 14.2 GREEN	
106	509-5003-03	PUSH BUTTON SW 1T \square 14.2 RED	
107	280-5009	CORD CLAMP ϕ 21	
201	000-0408-FS	M SCR PH W/FS M4x8	
202	031-0630-B	CRG BLT BLK M6x30	
203	008-0410	TMP PRF SCR TH M4x10	
204	050-0006	HEX NUT M6	

ASSY HANDLE U/R (GPD-20001)

(D-6/8)

ITEM NO.	PART NO.	DESCRIPTION	NOTE
205	000-0514-FS	M SCR PH W/FS M5×14	
206	000-0410-S	M SCR PH W/S M4×10	
207	001-0508	M SCR FH M5×8	
208	028-0003	SET SCR PH SPCL M3×8	
209	039-0102	CRG BLT M8×45	
210	059-0017	HEX NUT M12	
211	050-0008	HEX NUT M8	
212	054-0005	U NUT M5	
213	054-0006	U NUT M6	
214	029-0129	HEX SKT H CAP SCR BLK M6×25	
215	006-3525	W SCR FH 3.5×25	
216	069-0030	SPR WSHR M12	
217	061-0008	SPR WSHR M8	
218	061-0006	SPR WSHR M6	
219	061-0005	SPR WSHR M5	
220	060-0006	FLT WSHR M6	
221	069-0106	FLT WSHR 4.4-12×1.6	
222	060-0004	FLT WSHR M4	
223	060-0008	FLT WSHR M8	
224	001-0306	M SCR FH M3×6	
225	069-0109	FLT WSHR 8.2-15×0.1	
226	090-0012	SCREW LOCK	
227	090-0013	GREASE	
228	000-0416-FS	M SCR PH W/FS M4×16	
229	054-0004	U NUT M4	
230	000-0525-FS	M SCR PH W/FS M5×25	

ASSY HANDLE U/R (GPD-20001)

(D-7/8)

ITEM NO.	PART NO.	DESCRIPTION	NOTE
231	028-0012	SET SCR CH SPCL M5×12	
301	600-5879-10	CONN HANDLE EXT	
302	SGB-4034-13	WIRE HARN ANGLE VR	
	211-5282-03WH	CONN PLUG 9090 03P-WH	
303	SGB-4034-14	WIRE HARN ACCELE & BRAKE VR	
	211-5274-04RE	CONN PLUG AMP MINI 04P-RE	
304	SGB-4034-15	WIRE HARN SHIFT SW	
	211-5274-03BL	CONN PLUG AMP MINI 03P-BL	
	280-0472	FASTON RCPT 110	
305	SGB-4034-16	WIRE HARN START SW	
	211-5274-04WH	CONN PLUG AMP MINI 04P-WH	
	280-0472	FASTON RCPT 110	
	601-5904	ONE TOUCH SLEEVE 110	
306	SGB-4034-22	WIRE HARN EARTH HANDLE	
	211-5282-01GR	CONN PLUG 9090 01P-GR	
	211-0167	TERM LUG RND ID 5	
307	211-5276	CONN PIN AMP MINI AWG 26-22	
308	211-5277	CONN PIN AMP MINI AWG 22-18	
309	211-5284	CONN PIN 9090 AWG 18-24	
310	211-5285	CONN PIN 9090 AWG 14-20	
311	280-0425	CORD CLAMP ∅ 10	
312	280-5008	CORD CLAMP ∅ 15	
313	601-0460	TIE BELT 85mm	
	211-5275-03BL	CONN CAP AMP MINI 03P-BL	
	211-5275-04RE	CONN CAP AMP MINI 04P-RE	

ASSY HANDLE U/R (GPD-20001)

(D-8/8)

ITEM NO.	PART NO.	DESCRIPTION	NOTE
	211-5275-04WH	CONN CAP AMP MINI 04P-WH	

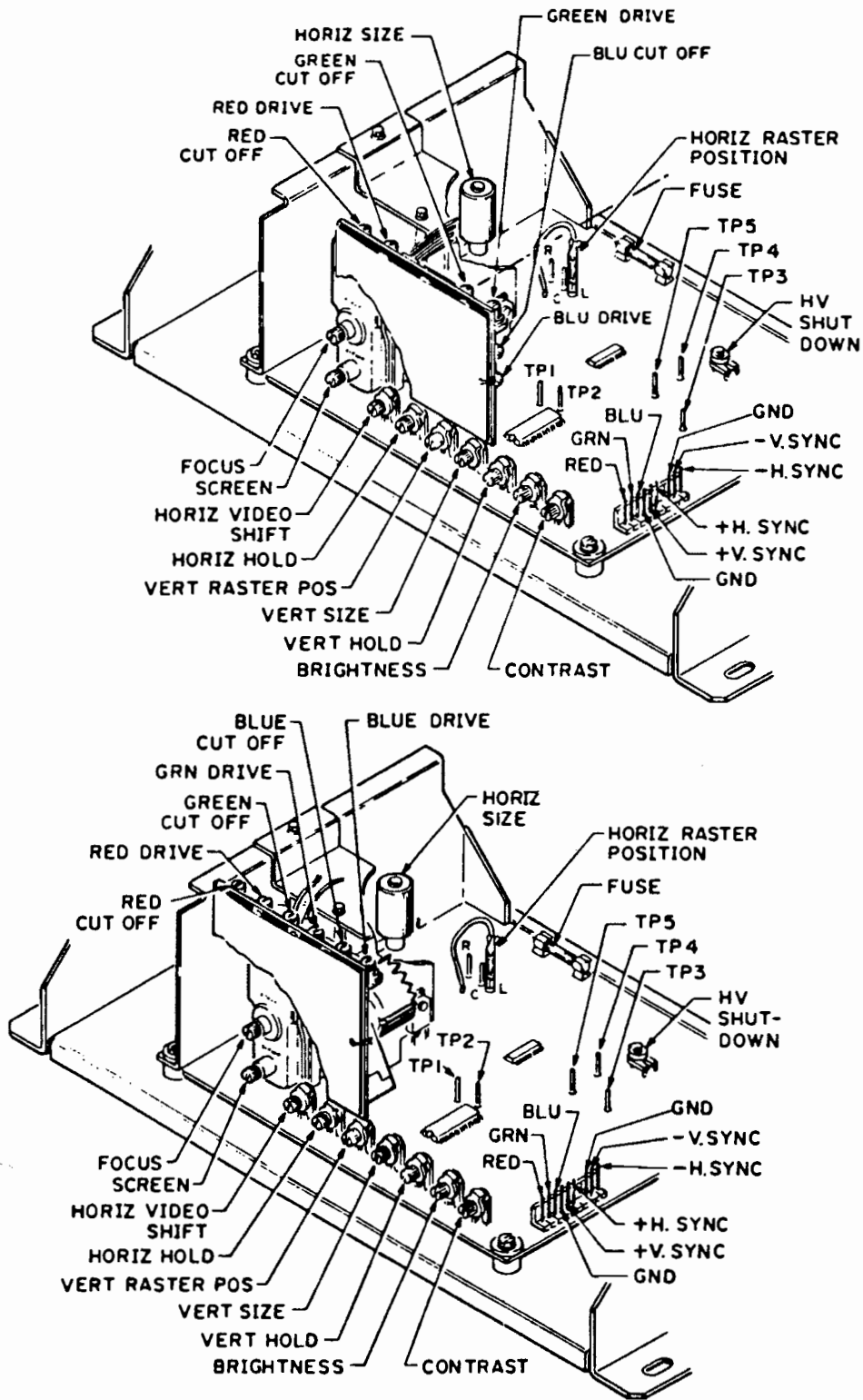

MONITOR ADJUSTMENTS

TEST MODE

The main purposes of these tests are to check the operations of the game boards, to find defects if any, to adjust the monitor colors properly, and to make sure the sounds are produced satisfactorily.

1. Selection of Test Items

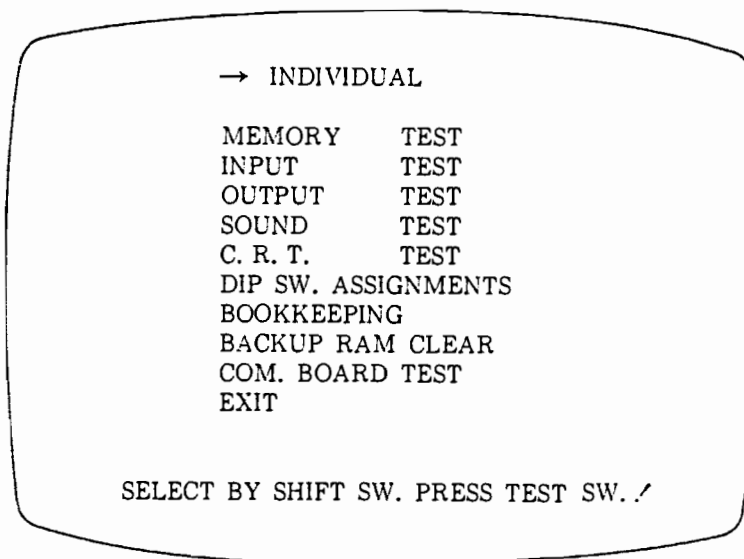

- (1) By pushing the TEST SW, the following test item menu can be displayed.
- (2) Push the SHIFT SW to move the arrow mark "→" downward. Bring the "→" mark to the desired TEST item and push the TEST SW again.
- (3) When the test has been completed, move the "→" mark to EXIT and push the TEST SW.

2. Test Items and Details

- (1) Memory Test: To check if the on-board Memory IC's and Custom IC's are normal or not. If the IC is normal, "GOOD" is indicated and if it is not normal, "BAD" will be displayed.

```
MEMORY TEST

**ROMS TEST**
IC. 20 GOOD  IC. 21 GOOD  IC. 58 GOOD
IC. 29 GOOD  IC. 30 GOOD  IC. 63 GOOD

**RAMS TEST**
IC. 22 GOOD  IC. 31 GOOD  IC. 38 GOOD
IC. 23 GOOD  IC. 32 GOOD  IC. 39 GOOD
IC. 55 GOOD  IC. 60 GOOD  IC.125 GOOD
IC. 56 GOOD  IC. 61 GOOD  IC.126 GOOD
IC.132 GOOD  IC.134 GOOD  IC.150 GOOD
IC.133 GOOD  IC.135 GOOD  IC.151 GOOD

**CUSTOM IC TEST**
IC. 30 GOOD  IC. 37 GOOD  IC. 53 GOOD
IC.107 GOOD  IC.108 GOOD
```

When the test has been completed, push the TEST SW.

- (2) Input Test: To check the condition of each switch and potentiometers.

```
INPUT TEST

①      ②
COIN #1 OFF      START  OFF
COIN #2 OFF      SERVICE OFF
SHIFT A OFF
SHIFT B OFF

③      ④
BANK      80H
ACCEL      CCH
BRAKE      EAH
```

- ① SW
- ② ON/OFF condition
- ③ POTENTIOMETER
- ④ CURRENT VALUE
(HEXADECIMAL)

- o Operate the dip switches. When "ON" is indicated at the right side of a certain tested item, the item is OK.
- o If the data value increases when the handle is inclined to the right, or decreases when it is inclined to the left, the testing is OK (the data is indicated in hexadecimal values). Make adjustment in a manner so that in the static condition, the value shows 80H (within the range of 7CH~84H).
- If the data value decreases, becomes CCH ± 04H (C8H~D0H) and becomes under 50H, when, respectively, the ACCELERATOR is applied, released and fully opened; then it is satisfactory.
- If the data value decreases, becomes ECH ± 04H (E8H~F0H) and becomes under 70H, when, respectively, the BRAKE is applied, released and fully applied; then it is satisfactory.

(3) OUTPUT TEST

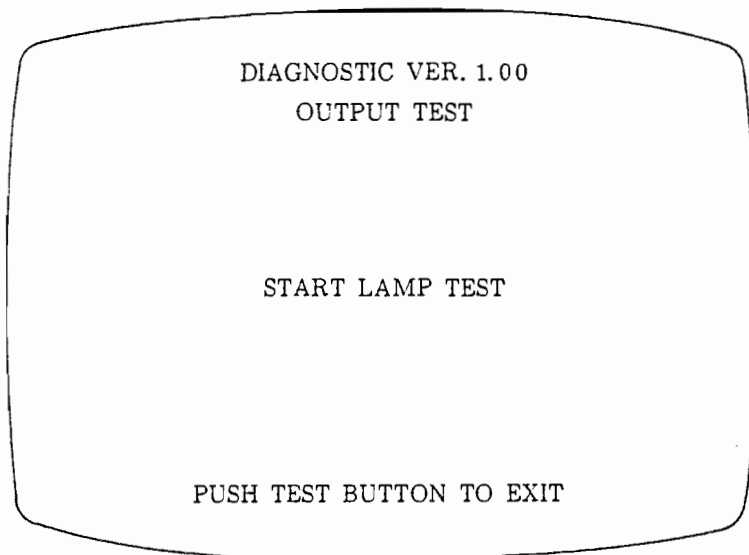

If the START LAMP lights up, it is functioning properly.
When the test has been completed, push the TEST SW.

(4) SOUND TEST

This test is to check sounds. By using the SHIFT SW, bring the "→" mark to the desired Test Item and push the START SW.

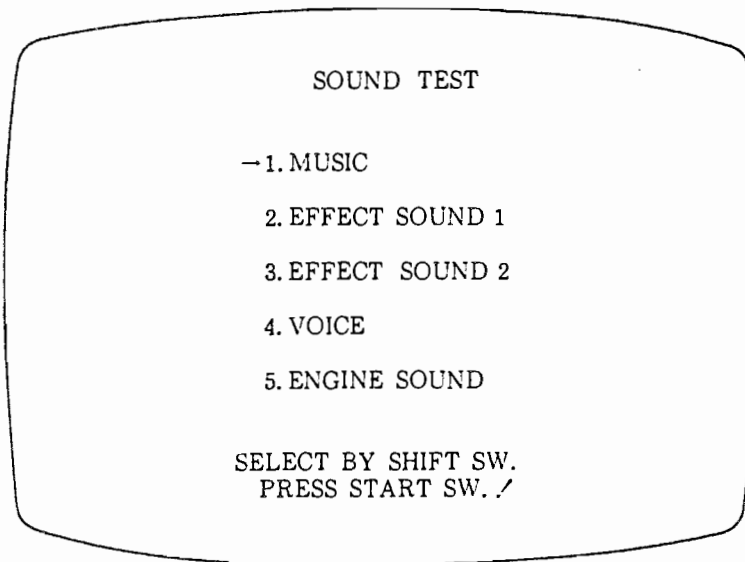

Push the START SW to change to next page.

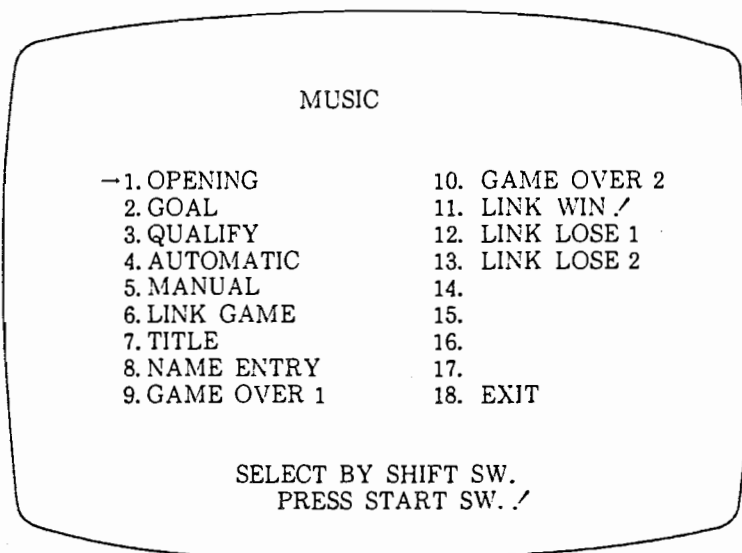

The test incorporates tests for 13 kinds of B.G.M., 33 kinds of SOUND EFFECTs and 11 kinds of VOICEs and ENGINE SOUNDS.

When the test has been completed, push the TEST SW.

(5) CRT TEST

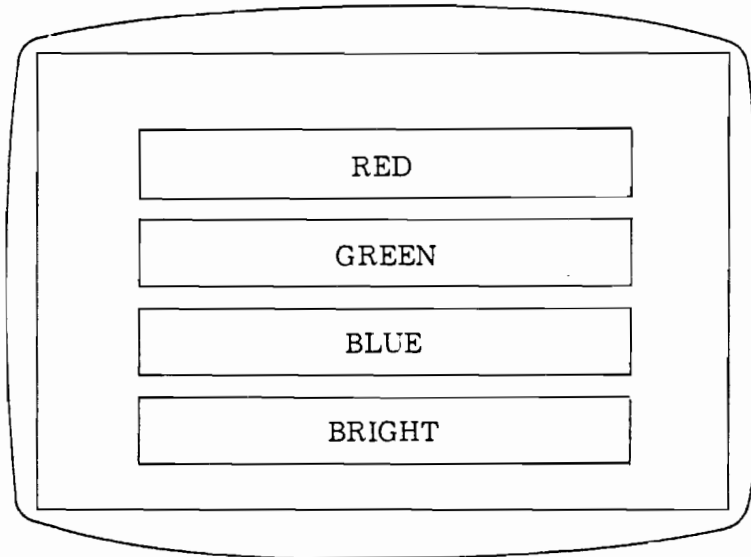

• RED, GREEN, BLUE

The color becomes darker from the left to the right.

• BRIGHT

The color becomes darker from the left to the right.

(6) DIP SWITCH ASSIGNMENTS

Displays the condition of DIP SW A and B.

For details, see the page(s) explaining the DIP SW.

DIP SWITCH ASSIGNMENTS

	1	2	3	4	5	6	7	8
DIP SW. A	OFF	OFF	OFF	OFF	OFF	OFF	OFF	OFF
DIP SW. B	OFF	OFF	OFF	OFF	OFF	OFF	OFF	OFF

- A1234 COIN SW #1 1 COIN 1 CREDIT
- A5678 COIN SW #2 1 COIN 1 CREDIT
- B12 CABINET TYPE RIDE ON
- B3 NO USE
- B4 ID NO. 1 (MAIN)
- B5 ADVERTISE SOUND ON
- B6 NO USE
- B78 GAME DIFFICULTY NORMAL

DIP SW. A

COIN SW SETTING

DIP SW. B

SETTING OF THE GAME

DIFFICULTY

When the test has been completed,
push the TEST SW.

(7) BOOKKEEPING

Page 1: Indicates the record of the number of coins and credits.

BOOKKEEPING		
① COIN CHUTE 1		0
② COIN CHUTE 2		0
③ COIN CREDITS		0
④ SERVICE CREDITS		0
⑤ TOTAL CREDITS		0
⑥ TOTAL TIME	00H00M00S	
PRESS START SW./		

- ① Usage frequency of Coin Chute 1
- ② Usage frequency of Coin Chute 2
- ③ Number of Coin Credits
- ④ Number of SERVICE CREDITS
- ⑤ Total Number of Credits
- ⑥ Total time during which the machine is energized.

Push the START SW to change to Page 2.

o Page 2: Indicates the record of game time distribution.

BOOKKEEPING		
NUMBER OF GAMES	0	①
AVR. SCORE	0	②
TOP SCORE	0	③
LOW SCORE	0	④
GAME TIME		
TOTAL	00H00M00S	⑤
AVERAGE	00H00M00S	⑥
LONGEST	00H00M00S	⑦
PRESS START SW./		

- ① Number of Games
- ② Average score
- ③ Highest score
- ④ Lowest score
- ⑤ Total game hours
- ⑥ The longest game time

Push the START SW to change to page 3.

- Displays the COURSE RECORD, number of AUTOMATIC / MANUAL game plays, and the DATA of by-lap GAME OVER.

BOOKKEEPING		
COURSE REC.	00M00S00	①
AUTOMATIC		②
MANUAL		③
LAP 1		④
LAP 2		⑤
LAP 3		⑥
LAP 4		⑦
GOAL		⑧

PRESS START SW.!

- ① COURSE RECORD
- ② Number of AUTOMATIC game plays
- ③ Number of MANUAL game plays
- ④ Number of 1 lap GAME OVER
- ⑤ Number of 2 laps GAME OVER
- ⑥ Number of 3 laps GAME OVER
- ⑦ Number of 4 laps GAME OVER
- ⑧ Number of GOAL

Push the START SW to change to Page 1. When the test has been completed, push the TEST SW.

(8) BACKUP RAM CLEAR

In this test, the content of the BOOKKEEPING data can be cleared. When desiring to clear the data, bring the "→" mark to "YES" by using the START SW and push the TEST SW, and when not desiring to clear, bring the "→" mark to "NO" by using the START SW and push the TEST SW.

BACKUP RAM CLEAR	
→	NO
→	YES

SELECT BY SHIFT SW.
PRESS TEST SW.!

When BACKUP RAM clear is finished. "COMPLETED" will be shown on the screen.

(9) COM. BOARD TEST

- In the COMMUNICATION BOARD TEST mode, the COM. BOARD (837-7273) check is performed. Carry out the test for both PLAYER 1 and 2 simultaneously.

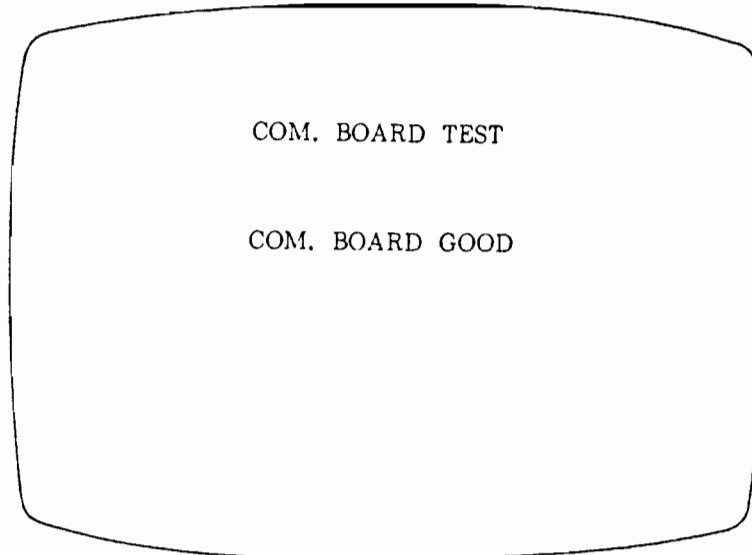

- If the COM. BOARD is satisfactory, "COM. BOARD GOOD" will be displayed.

When the test has been completed, push the TEST SW.

- (10) • To end the TEST mode, select "EXIT" on the MENU screen and press the TEST SW.

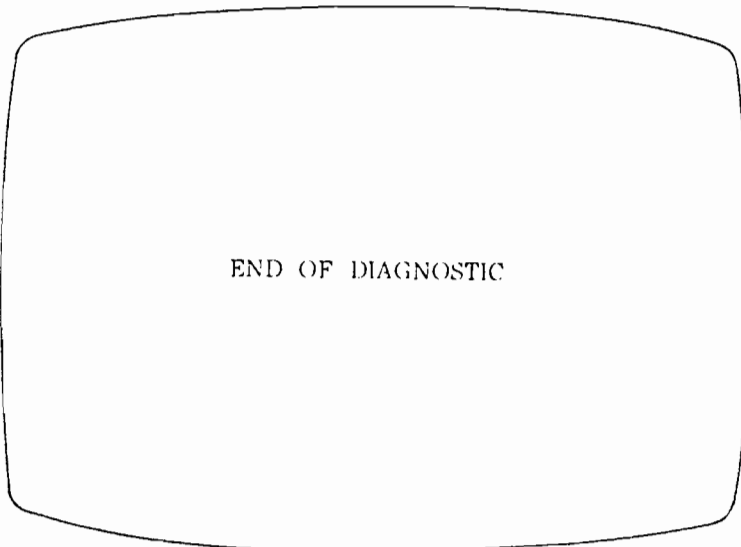

The TEST mode ends with "END OF DIAGNOSTICS" displayed on the screen.

DIP SWITCH

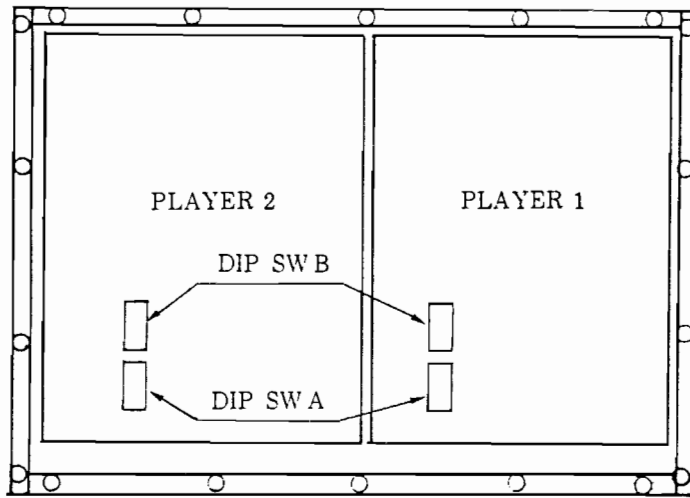

COIN/CREDIT OPTION SW. SETTING

DIP SW. A

		1	2	3	4	5	6	7	8
1 COIN	1 CREDIT	OFF	OFF	OFF	OFF	OFF	OFF	OFF	OFF
1 COIN	2 CREDITS	ON	OFF	OFF	OFF	ON	OFF	OFF	OFF
1 COIN	3 CREDITS	OFF	ON	OFF	OFF	OFF	ON	OFF	OFF
5 COINS	1 CREDIT	ON	ON	OFF	OFF	ON	ON	OFF	OFF
6 COINS	1 CREDIT	OFF	OFF	ON	OFF	OFF	OFF	ON	OFF
1 COIN	6 CREDITS	ON	OFF	ON	OFF	ON	OFF	ON	OFF
2 COINS	1 CREDIT	OFF	ON	ON	OFF	OFF	ON	ON	OFF
3 COINS	1 CREDIT	ON	ON	ON	OFF	ON	ON	ON	OFF
4 COINS	1 CREDIT	OFF	OFF	OFF	ON	OFF	OFF	OFF	ON
2 COINS	3 CREDITS	ON	OFF	OFF	ON	ON	OFF	OFF	ON
2 COINS	1 CREDIT								
3 COINS	2 CREDITS	OFF	ON	OFF	ON	OFF	ON	OFF	ON
5 COINS	3 CREDITS								
6 COINS	4 CREDITS								
2 COINS	1 CREDIT	ON	ON	OFF	ON	ON	ON	OFF	ON
4 COINS	3 CREDITS								
1 COIN	1 CREDIT								
2 COINS	2 CREDITS								
3 COINS	3 CREDITS	OFF	OFF	ON	ON	OFF	OFF	ON	ON
4 COINS	4 CREDITS								
5 COINS	6 CREDITS								
1 COIN	1 CREDIT	ON	OFF	ON	ON	ON	OFF	ON	ON
2 COINS	2 CREDITS								
3 COINS	3 CREDITS								
4 COINS	5 CREDITS								
1 COIN	1 CREDIT	OFF	ON	ON	ON	OFF	ON	ON	ON
2 COINS	3 CREDITS								
FREE PLAY		ON	ON	ON	ON	ON	ON	ON	ON
				COIN SW #1		COIN SW #2			

GAME OPTION SW. SETTING

DIP SW. B

		1	2	3	4	5	6	7	8
CABINET	PRIDE ON	OFF	OFF						
TYPE	UPRIGHT	ON	OFF						
PLAYER 1 (BLUE)				NOT USED	OFF		NOT USED		
PLAYER 2 (RED)					ON				
ADVERTISE	ON			NOT USED		OFF	NOT USED		
SOUND	OFF								
GAME DIFFICULTY	NORMAL							OFF	OFF
	EASY							ON	OFF
	HARD							OFF	ON
	HARDEST							ON	ON

EPROM LOCATIONS

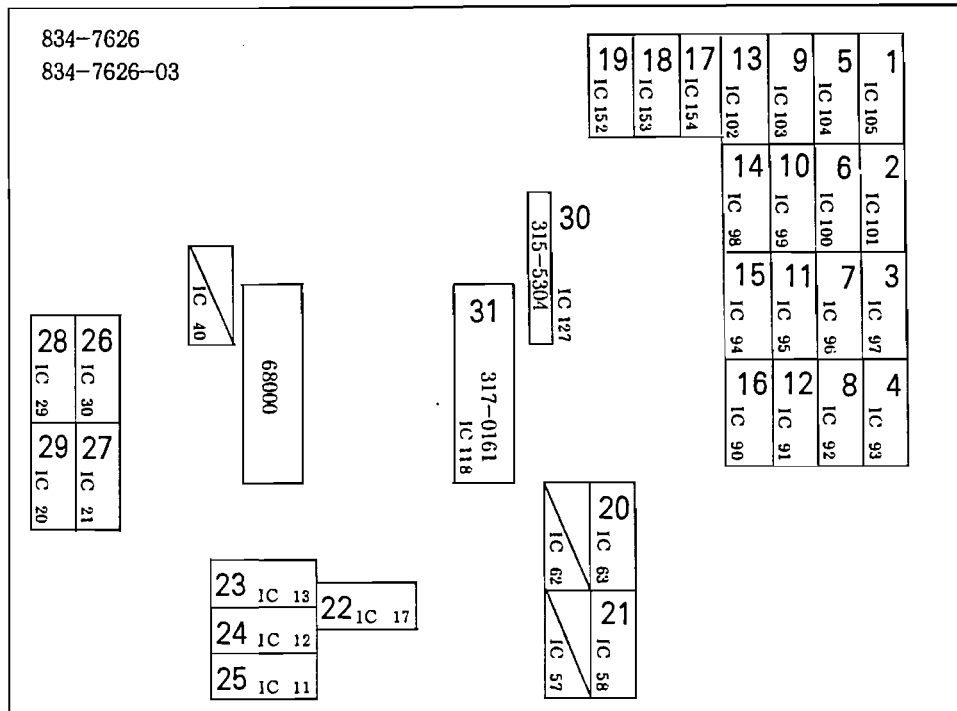

		U.S.A.		EXPORT			
IC	BD NUMBER	834-7626-01	834-7626-04	834-7626-02	834-7626-05		
IC	LOCATION	ROM NUMBER				MAIN WORK	
1	IC105	EPR-13367				1M-20 OBJECT (CHARACTER & SCENE SCENERY)	
2	IC101	EPR-13368					
3	IC 97	EPR-13369					
4	IC 93	EPR-13370					
5	IC104	MPR-13371	EPR-13371	MPR-13371	EPR-13371		
6	IC100	MPR-13372	EPR-13372	MPR-13372	EPR-13372		
7	IC 96	MPR-13373	EPR-13373	MPR-13373	EPR-13373		
8	IC 92	MPR-13374	EPR-13374	MPR-13374	EPR-13374		
9	IC103	MPR-13375	EPR-13375	MPR-13375	EPR-13375		
10	IC 99	MPR-13376	EPR-13376	MPR-13376	EPR-13376		
11	IC 95	MPR-13377	EPR-13377	MPR-13377	EPR-13377		
12	IC 91	MPR-13378	EPR-13378	MPR-13378	EPR-13378		
13	IC102	MPR-13379	EPR-13379	MPR-13379	EPR-13379		
14	IC 98	MPR-13380	EPR-13380	MPR-13380	EPR-13380		
15	IC 94	MPR-13381	EPR-13381	MPR-13381	EPR-13381		
16	IC 90	MPR-13382	EPR-13382	MPR-13382	EPR-13382		
17	IC154	EPR-13383				512-20 FIX SCROLL CHARACTER	
18	IC153	EPR-13384					
19	IC152	EPR-13385					
20	IC 63	EPR-13406		EPR-13408		1M-20 MAIN PROGRAM	
21	IC 58	EPR-13407		EPR-13409			
22	IC 17	EPR-13388				512-20 SOUND PROGRAM	
23	IC 13	MPR-13389	EPR-13389	MPR-13389	EPR-13389	1M-20 SOUND DATA	
24	IC 12	MPR-13390	EPR-13390	MPR-13390	EPR-13390		
25	IC 11	MPR-13391	EPR-13391	MPR-13391	EPR-13391		
26	IC 30	EPR-13392				1M-20 SUB PROGRAM	
27	IC 21	EPR-13393					
28	IC 29	EPR-13394					
29	IC 20	EPR-13395					
30	IC127	315-5304				— CUSTOM CHIP	
31	IC118	317-0162		317-0163		— SECURITY CHIP	

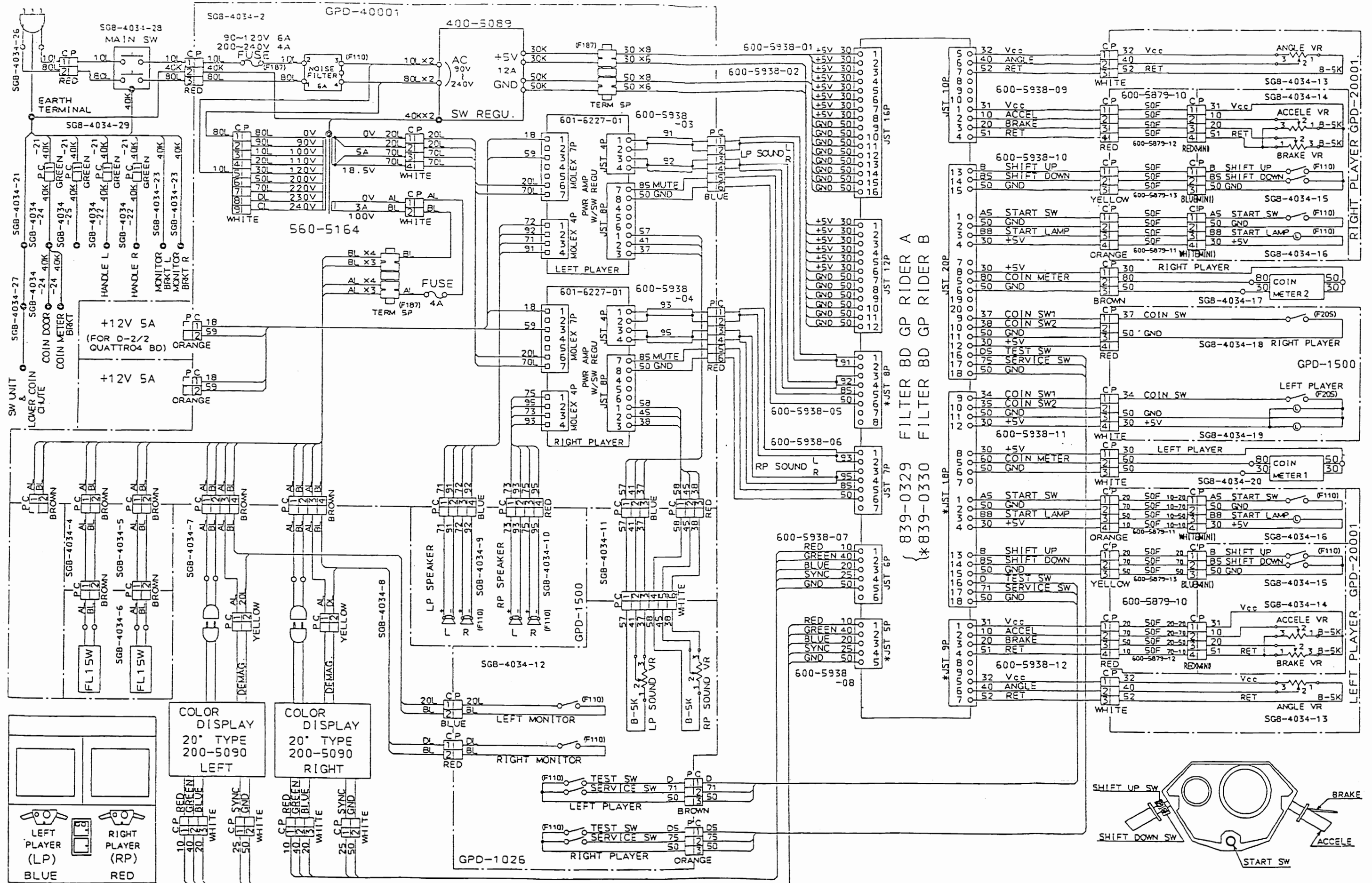

19. WIRING DIAGRAM (1/2)

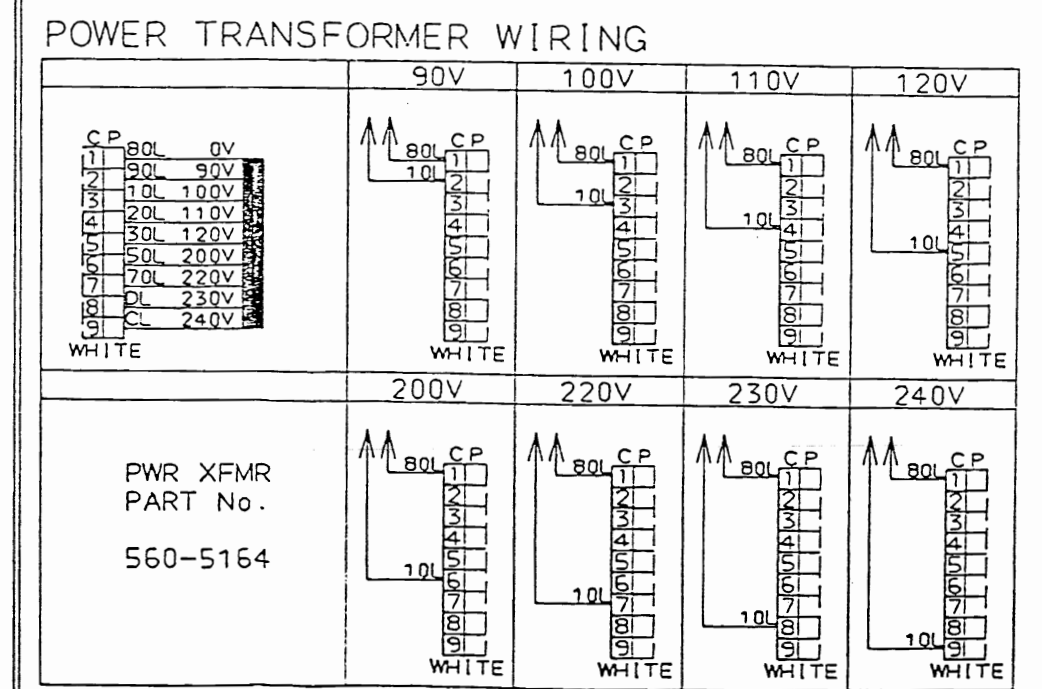
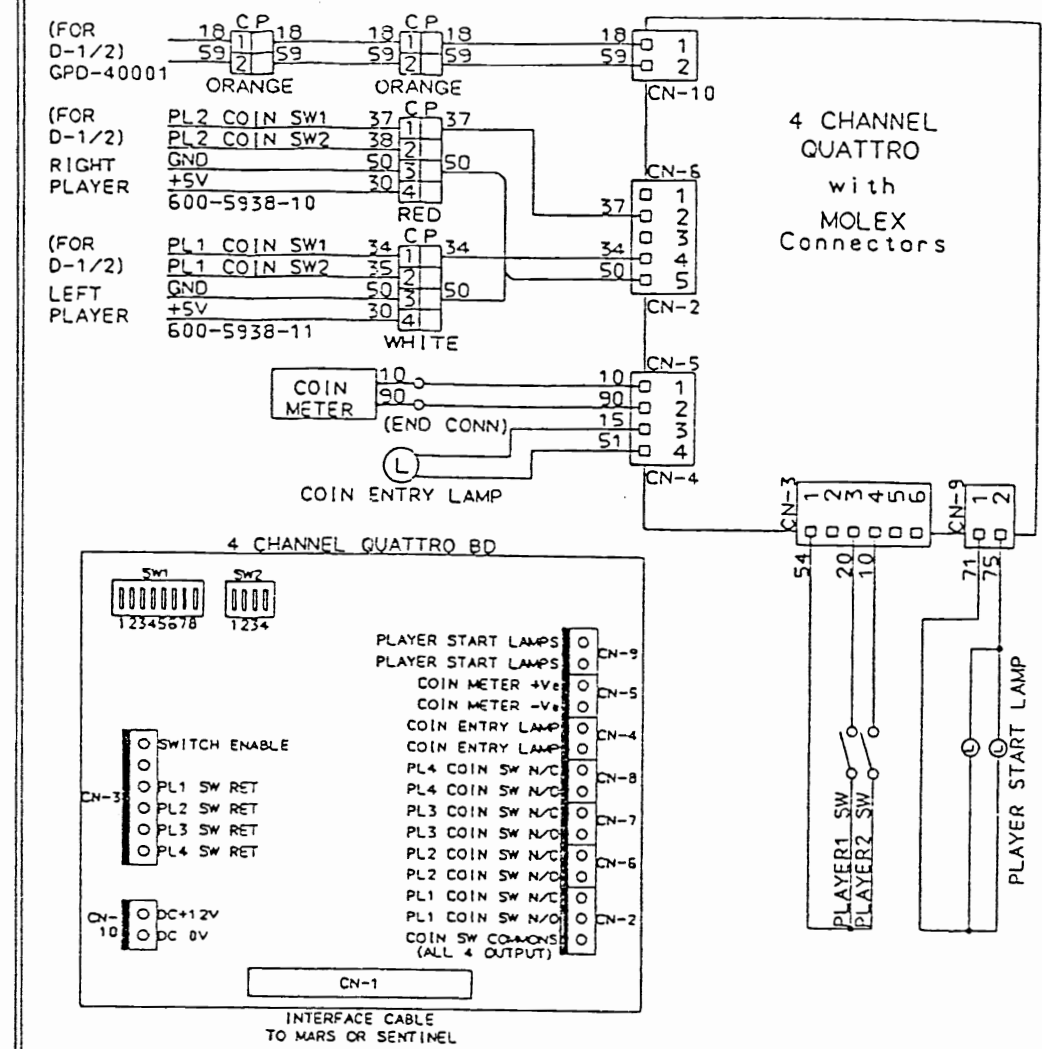
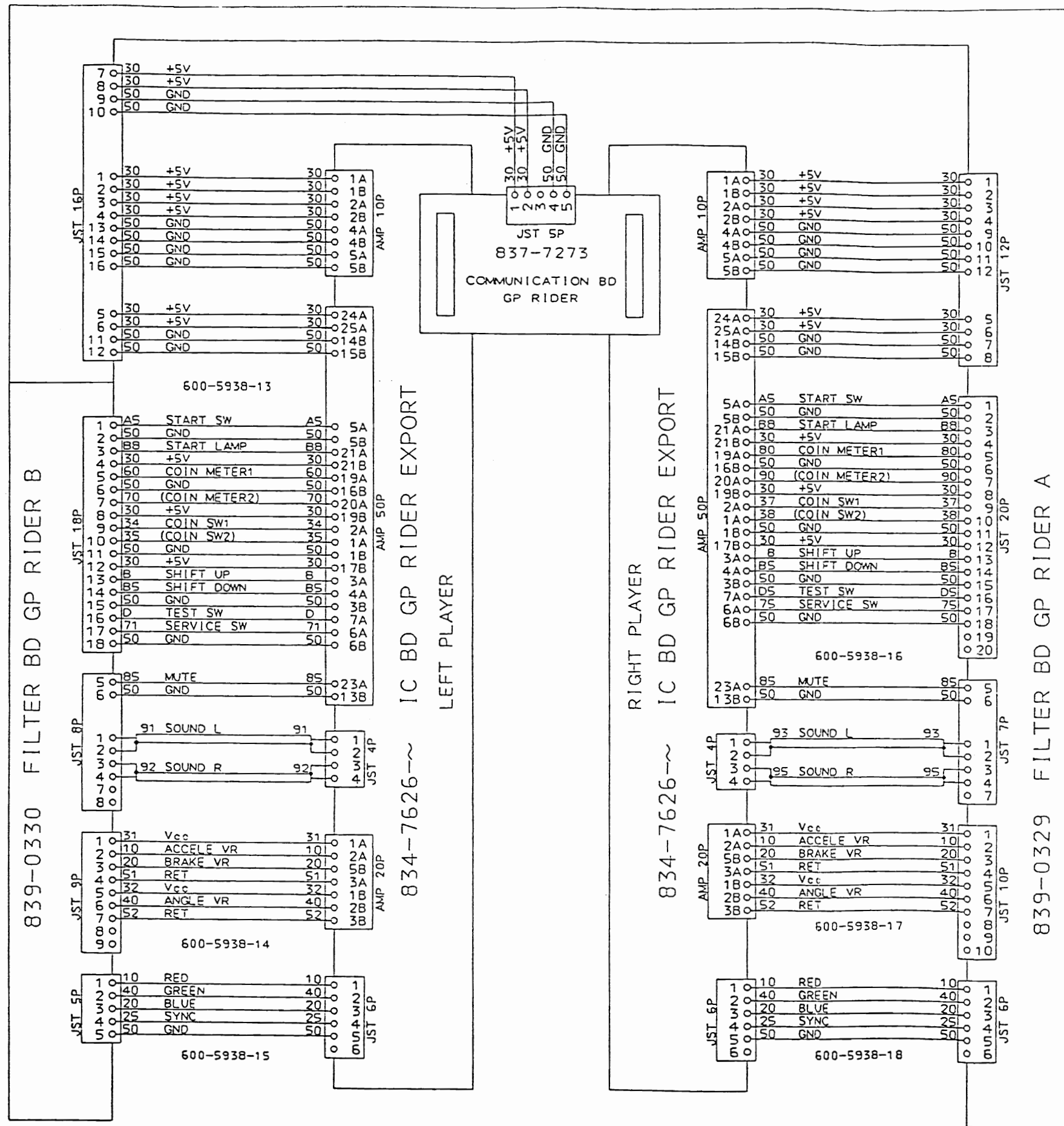

20. WIRING DIAGRAM (2/2)